

tm2258 - 450J, 550J, 650J Crawler Dozer (S.N. —141666) Technical Manual

Table of Contents

Foreword

HELP!! HELP!! HELP!! HELP!!

Section 00: General Information

Group 01: Safety

Recognize Safety Information

Follow Safety Instructions

Operate Only If Qualified

Wear Protective Equipment

Avoid Unauthorized Machine Modifications

Inspect Machine

Stay Clear of Moving Parts

Avoid High-Pressure Fluids

Beware of Exhaust Fumes

Prevent Fires

Prevent Battery Explosions

Handle Chemical Products Safely

Dispose of Waste Properly

Prepare for Emergencies

Add Cab Guarding For Special Uses

Start Only From Operator's Seat

Prevent Unintended Machine Movement

Avoid Work Site Hazards

Keep Riders Off Machine

Avoid Backover Accidents

Avoid Machine Tip Over

Park And Prepare For Service Safely

Service Cooling System Safely

Remove Paint Before Welding or Heating

Make Welding Repairs Safely

Drive Metal Pins Safely

Group 03: Torque Values

Metric Bolt and Cap Screw Torque Values

Additional Metric Cap Screw Torque Values

Unified Inch Bolt and Cap Screw Torque Values

Service Recommendations for 37° Flare and 30° Cone Seat Connectors

Service Recommendations for O-Ring Boss Fittings

O-Ring Boss Fittings In Aluminum Housing Service Recommendations—Excavators

Service Recommendations for Flared Connections—Straight or Tapered Threads

Service Recommendations For Flat Face O-Ring Seal Fittings

O-Ring Face Seal Fittings With SAE Inch Hex Nut And Stud End For High Pressure Service Recommendations

O-Ring Face Seal Fittings With Metric Hex Nut And Stud End For Standard Pressure Service Recommendations

O-Ring Face Seal Fittings With Metric Hex Nut And Stud End For High Pressure Service Recommendations

Service Recommendations for Metric Series Four Bolt Flange Fitting

Service Recommendations For Inch Series Four Bolt Flange Fittings

Inch Series Four Bolt Flange Fitting For High Pressure Service Recommendations

Service Recommendations For Non-Restricted Banjo (Adjustable) Fittings

Service Recommendations For O-Ring Boss Fittings With Shoulder

Metric 24° O-Ring Seal DIN 20078 Service Recommendations

Section 01: Tracks

Group 0130: Track System

Rock Guards and Chain Guides Remove and Install

Carrier Roller Remove and Install

Carrier Roller Disassemble and Assemble

Metal Face Seals Inspection

Track Roller Remove and Install

Track Roller Disassemble and Assemble

Track Roller Leakage Test

Track Shoe Remove and Install

Sealed Track Chain Removal

Sealed Track Chain Disassemble and Assemble

Sealed Track Chain Installation

Lubricated Track Chain (Saw Tooth Master Split Link) Remove and Install

Lubricated Track Chain Disassembly (Turn Bushings and Lubricate Chain)

Lubricated Track Chain Assembly (Turn Bushings and Lubricate Chain)

Lubricated Track Chain Disassemble and Assemble (Turn Pins and Not Lubricate)

Front Idler Remove and Install

Front Idler Disassemble, Inspect, and Assemble

Front Idler Adjustment

Front Idler Oil Level Check

Track Tension Adjuster Remove and Disassemble

Track Tension Adjuster Assemble and Install

Track Idler Recoil Spring Remove and Install

Track Idler Recoil Spring Disassemble and Assemble

Sprocket Remove and Install

Track Frame Remove and Install

Track Frame Disassemble and Assemble

Frame Wear Strips Remove and Install

Section 02: Axles and Suspension Systems

Group 0201: Drive Axle Housing and Support

Final Drive Remove and Install

Group 0250: Axle Shaft, Bearings, and Reduction Gear

Final Drive Disassemble and Assemble

Section 03: Transmission

Group 0300: Removal and Installation

Hydrostatic Pump Remove and Install

Hydrostatic Motor Remove and Install

Group 0315: Controls Linkage

Transmission Control Lever (TCL) Remove and Install

Transmission Control Lever (TCL) Disassemble and Assemble (S.N. —130885)

Group 0360: Hydrostatic System

Hydrostatic Pumps Disassemble

Hydrostatic Charge Pump Disassemble and Assemble

Pump Displacement Control Valve (PDCV) Disassemble and Assemble

Multi-Function Valve Disassemble and Assemble

Neutral Charge Relief Valve Disassemble and Assemble

Hydrostatic Pump Assemble

Hydrostatic Motor Disassemble

Hydrostatic Motor Assemble

Oil Cooler Thermal Bypass Valve Remove and Install

Hydrostatic Filter Remove and Install

Hydrostatic Filter Disassemble and Assemble

Hydrostatic Reservoir Remove and Install

Section 04: Engine

Group 0400: Removal and Installation

Engine Remove and Install

Section 05: Engine Auxiliary Systems

Group 0505: Cold Weather Starting Aids

Engine Coolant Heater Remove and Install

Start Aid Remove and Install

Starting Aid Solenoid Remove and Install

Group 0510: Radiator and Fan Shroud

Fan Blade and Shroud Remove and Install (450J, 550J)

Fan Blade and Shroud Remove and Install (650J)

Cooling Package Remove and Install (450J, 550J)

Cooling Package Remove and Install (650J)

Sand Shield Remove and Install

Group 0515: Engine Speed Control

Decelerator/Brake Pedal Remove and Install

Decelerator/Brake Pedal Disassemble and Assemble

Group 0520: Intake System

Air Cleaner Remove and Install 550J and 650J

Group 0530: External Exhaust System

Muffler Without Turbocharger Remove and Install

Muffler With Turbocharger Remove and Install

Group 0540: Mounting Frame

Engine and Power Train Mounting

Group 0560: External Fuel Supply System

Fuel Tank Remove and Install

Section 07: Dampener Drive

Group 0752: Elements

Dampener Drive Remove and Install

Section 11: Park Brake

Group 1100: Removal and Installation

Park Brake Valve Remove and Install

Park Brake Remove and Install

Group 1115: Control Linkage

Park Lock Linkage Remove and Install

Park Lock Linkage Disassemble and Assemble

Group 1160: Hydraulic System

Park Brake Valve Disassemble and Assemble

Park Brake Disassemble and Assemble

Section 18: Operator's Station

Group 1800: Removal and Installation

Cab or ROPS Remove and Install

Group 1810: Operator's Enclosure

Slide Glass Remove and Install

Stationary Glass Remove and Install

Sliding Window Remove and Install

Front Window Wiper Remove and Install

Door Window Wipers Remove and Install

Rear Window Wiper Remove and Install

Window Washer Pumps Remove and Install

Group 1821: Seat and Seat Belt

Standard Seat Remove and Install (Old)

Deluxe Seat Remove and Install

Air Suspension Seat Remove and Install

Group 1830: Heating and Air Conditioning

R134a Refrigerant Cautions

R134a Compressor Oil Charge Check

R134a Compressor Oil Removal

R134a Component Oil Charge

Leakage Testing

R134a Refrigerant Recovery, Recycling and Charging Station Installation Procedure

Recover R134a System

Evacuate R134a System

Charge R134a System

Air Conditioner System Cleaning Procedures

Purge R134a System

Flush R134a System

Evaporator or Heater Core Remove and Install

Expansion Valve Remove and Install

A/C Freeze Switch Remove and Install

Upper Cab Heater Blower Motor and Heater Blower Resistor Remove and Install

Cab Upper Heater Disassemble and Assemble

Cab or ROPS Under Seat Heater Disassemble and Assemble

Receiver-Dryer Remove and Install

Condenser Remove and Install

Compressor Remove and Install

Compressor Remove and Install

Compressor Clutch Disassemble and Assemble

Clutch Hub Clearance Check

Compressor Manifold Inspect

Compressor Disassemble and Assemble

Section 19: Sheet Metal and Styling

Group 1910: Hood and Engine Enclosure

Hood Remove and Install

Hood Support and Engine Side Shields Remove and Install

Group 1921: Grille and Grille Housing

Grille and Grille Housing Removal

Grille and Grille Housing Installation

Section 21: Main Hydraulic System

Group 2160: Hydraulic System

Hydraulic Pump Remove and Install

Hydraulic Pump (With Winch Option) Disassemble and Assemble

Hydraulic Pump (Without Winch Option) Disassemble and Assemble

Hydraulic Reservoir Remove and Install

Hydraulic Reservoir and Hydrostatic Reservoir Cleanout Cover Remove and Install

Hydraulic Reservoir Disassemble and Assemble

Hydraulic Filter Remove and Install

Hydraulic Filter Disassemble and Assemble

Section 32: Bulldozer

Group 3201: Blades

Blade Remove and Install

Blade Ball and Socket Alignment Procedure

Blade Retainer Split Bearing Installation

Cutting Edges and End Bits Remove and Install

Group 3215: Control Linkage

Hydraulic Control Lever Linkage Remove and Install

Auxiliary Hydraulic Control Lever Linkage Remove and Install

Group 3240: Frames

C-Frame Remove and Install

Group 3260: Hydraulic System

Hydraulic Control Valve Remove and Install

Hydraulic Control Valve Disassemble and Assemble

Wiper Seals and Lip Seals on Hydraulic Control Valve Remove and Install

Auxiliary Control Valve Section Disassemble and Assemble

Angle Control Valve Section Disassemble and Assemble

Tilt Control Valve Section Disassemble and Assemble

Lift Control Valve Section Disassemble and Assemble

Integrated Grade Control (IGC) Lever Remove and Install (S.N. 130886—)

Integrated Grade Control (IGC) Lever Disassemble and Assemble (S.N. 130886—)

System and Angle Circuit Relief Valve Disassemble and Assemble

Tilt Cylinder Remove and Install

Angle Cylinder Remove and Install

Lift Cylinder Remove and Install

Angle, Lift, and Tilt Cylinders Disassemble and Assemble (John Deere 120 Series Cylinders)

Section 9900: Dealer Fabricated Tools

Group 0999: Dealer Fabricated Tools

DF1041 Track Nut Removal Tool

DF1063 Final Drive Lift Bracket

DFT1087 Track Recoil Spring Disassembly and Assembly Guard Tool

DFT1119 Pump Support

DFT1130 Adapter

DFT1132 Hydrostatic Motor Removal and Installation Tool

DFT1137 Hydrostatic Motor Removal and Installation Tool

DFT1165 Left Hand Hydrostatic Motor Lifting Bracket

DFT1166 Final Drive Lifting Bracket Adapter

DFT1167 Final Drive Lifting Bracket Adapter Spacer

DFT1168 Right Hand Hydrostatic Motor Lifting Bracket

DFT1211 Final Drive Lifting Bracket Adapter

DFRW20 Compressor Holding Fixture

ST4920 Track Recoil Spring Disassembly and Assembly Tool

Foreword

This manual is written for an experienced technician. Essential tools required in performing certain service work are identified in this manual and are recommended for use.

Live with safety: Read the safety messages in the introduction of this manual and the cautions presented throughout the text of the manual.

**⚠ CAUTION:**

This is the safety-alert symbol. When you see this symbol on the machine or in this manual, be alert to the potential for personal injury.

Technical manuals are divided in two parts: repair and operation and tests. Repair sections tell how to repair the components. Operation and tests sections help you identify the majority of routine failures quickly.

Information is organized in groups for the various components requiring service instruction. At the beginning of each group are summary listings of all applicable essential tools, service equipment and tools, other materials needed to do the job, service parts kits, specifications, wear tolerances, and torque values.

Technical Manuals are concise guides for specific machines. They are on-the-job guides containing only the vital information needed for diagnosis, analysis, testing, and repair.

Fundamental service information is available from other sources covering basic theory of operation, fundamentals of troubleshooting, general maintenance, and basic type of failures and their causes.

TE14778,000003E-19-20040519

Section 00: General Information

Group 01: Safety

- Recognize Safety Information**
- Follow Safety Instructions**
- Operate Only If Qualified**
- Wear Protective Equipment**
- Avoid Unauthorized Machine Modifications**
- Inspect Machine**
- Stay Clear of Moving Parts**
- Avoid High-Pressure Fluids**
- Beware of Exhaust Fumes**
- Prevent Fires**
- Prevent Battery Explosions**
- Handle Chemical Products Safely**
- Dispose of Waste Properly**
- Prepare for Emergencies**
- Add Cab Guarding For Special Uses**
- Start Only From Operator's Seat**
- Prevent Unintended Machine Movement**
- Avoid Work Site Hazards**
- Keep Riders Off Machine**
- Avoid Backover Accidents**
- Avoid Machine Tip Over**
- Park And Prepare For Service Safely**
- Service Cooling System Safely**
- Remove Paint Before Welding or Heating**
- Make Welding Repairs Safely**
- Drive Metal Pins Safely**

Group 03: Torque Values

- Metric Bolt and Cap Screw Torque Values**
- Additional Metric Cap Screw Torque Values**
- Unified Inch Bolt and Cap Screw Torque Values**
- Service Recommendations for 37° Flare and 30° Cone Seat Connectors**

Service Recommendations for O-Ring Boss Fittings

O-Ring Boss Fittings In Aluminum Housing Service Recommendations—Excavators

Service Recommendations for Flared Connections—Straight or Tapered Threads

Service Recommendations For Flat Face O-Ring Seal Fittings

O-Ring Face Seal Fittings With SAE Inch Hex Nut And Stud End For High Pressure Service Recommendations

O-Ring Face Seal Fittings With Metric Hex Nut And Stud End For Standard Pressure Service Recommendations

O-Ring Face Seal Fittings With Metric Hex Nut And Stud End For High Pressure Service Recommendations

Service Recommendations for Metric Series Four Bolt Flange Fitting

Service Recommendations For Inch Series Four Bolt Flange Fittings

Inch Series Four Bolt Flange Fitting For High Pressure Service Recommendations

Service Recommendations For Non-Restricted Banjo (Adjustable) Fittings

Service Recommendations For O-Ring Boss Fittings With Shoulder

Metric 24° O-Ring Seal DIN 20078 Service Recommendations

Recognize Safety Information

T133555-UN: Safety alert Symbols



T133588-19: Safety Alert Symbols

This is the safety alert symbol. When you see this symbol on your machine or in this manual, be alert for the potential of personal injury.

Follow the precautions and safe operating practices highlighted by this symbol.

A signal word — DANGER, WARNING, or CAUTION — is used with the safety alert symbol. DANGER identifies the most serious hazards.

On your machine, DANGER signs are red in color, WARNING signs are orange, and CAUTION signs are yellow. DANGER and WARNING signs are located near specific hazards. General precautions are on CAUTION labels.

Go to [Section_00:Group_01](#)

TX03679,00016CC-19-20180108

Recognize Safety Information



T133555-UN: Safety alert Symbols



T133588-19: Safety Alert Symbols

This is the safety alert symbol. When you see this symbol on your machine or in this manual, be alert for the potential of personal injury.

Follow the precautions and safe operating practices highlighted by this symbol.

A signal word — DANGER, WARNING, or CAUTION — is used with the safety alert symbol. DANGER identifies the most serious hazards.

On your machine, DANGER signs are red in color, WARNING signs are orange, and CAUTION signs are yellow. DANGER and WARNING signs are located near specific hazards. General precautions are on CAUTION labels.

Go to [Section_00:Group_01](#)

TX03679,00016CC-19-20180108

Follow Safety Instructions

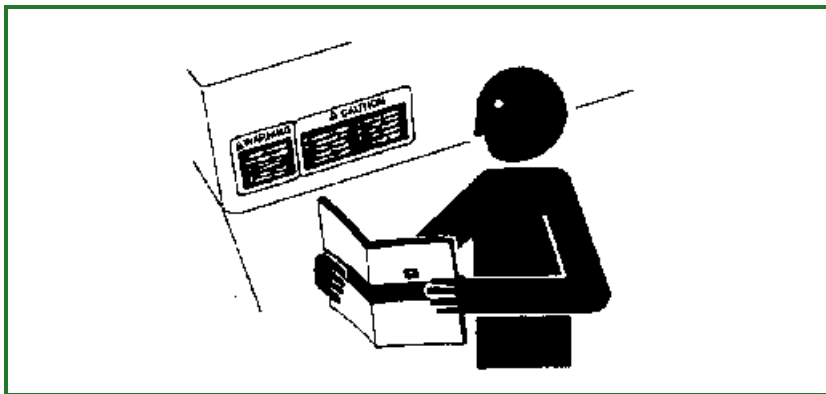

T133556-UN: Follow Safety Instructions

Read the safety messages in this manual and on the machine. Follow these warnings and instructions carefully. Review them frequently. Keep safety signs in good condition. Replace missing or damaged safety signs. Be sure new equipment components and repair parts include the current safety signs. Replacement safety signs are available from your John Deere dealer.

Be sure all operators of this machine understand every safety message. Replace operator's manual and safety labels immediately if missing or damaged.

Go to [Section_00:Group_01](#)

TX03679,00016F9-19-20080114

Operate Only If Qualified

Do not operate this machine unless the operator's manual has been read carefully, and you have been qualified by supervised training and instruction.

Operator should be familiar with the job site and surroundings before operating. Try all controls and machine functions with the machine in an open area before starting to work.

Know and observe all safety rules that may apply to every work situation and work site.

[Go to Section_00:Group_01](#)

TX03679,00016FA-19-20070103

Wear Protective Equipment

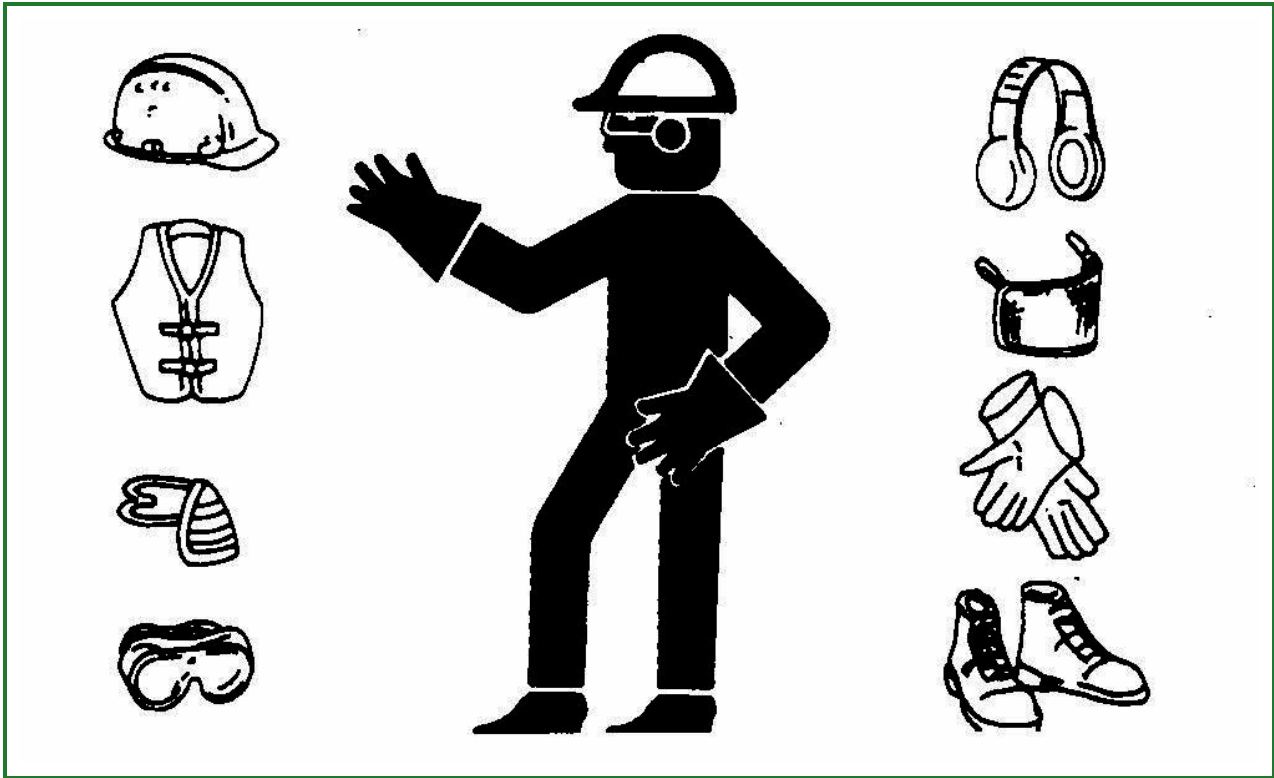

TS206-UN: Protective Equipment

Guard against injury from flying pieces of metal or debris; wear goggles or safety glasses.

Wear close fitting clothing and safety equipment appropriate to the job.

Prolonged exposure to loud noise can cause impairment or loss of hearing. Wear suitable hearing protection such as earmuffs or earplugs to protect against objectionable or uncomfortable loud noises.

[Go to Section_00:Group_01](#)

TX03679,00016D0-19-20100505

Avoid Unauthorized Machine Modifications

Modifications of this machine, or addition of unapproved products or attachments, may affect machine stability or reliability, and may create a hazard for the operator or others near the machine. The installer of any modification which may affect the electronic controls of this machine is responsible for establishing that the modification does not adversely affect the machine or its performance.

Always contact an authorized dealer before making machine modifications that change the intended use, weight or balance of the machine, or that alter machine controls, performance or reliability.

[Go to Section_00:Group_01](#)

TX03679,00016B7-19-20030812

Inspect Machine



T6607AQ-UN: Inspect Machine

Inspect machine carefully each day by walking around it before starting.

Keep all guards and shields in good condition and properly installed. Fix damage and replace worn or broken parts immediately. Pay special attention to hydraulic hoses and electrical wiring.

Go to [Section_00:Group_01](#)

TX03679,0001734-19-20080108

Stay Clear of Moving Parts

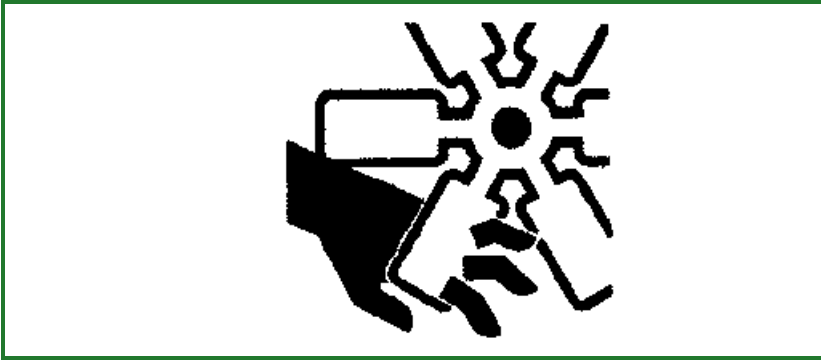

T133592-UN: Stay Clear of Moving Parts

Entanglements in moving parts can cause serious injury.

Stop engine before examining, adjusting or maintaining any part of machine with moving parts.

Keep guards and shields in place. Replace any guard or shield that has been removed for access as soon as service or repair is complete.

Go to [Section_00:Group_01](#)

TX03679,00016D2-19-20080108

Avoid High-Pressure Fluids



T133509-UN: Avoid High Pressure Fluids

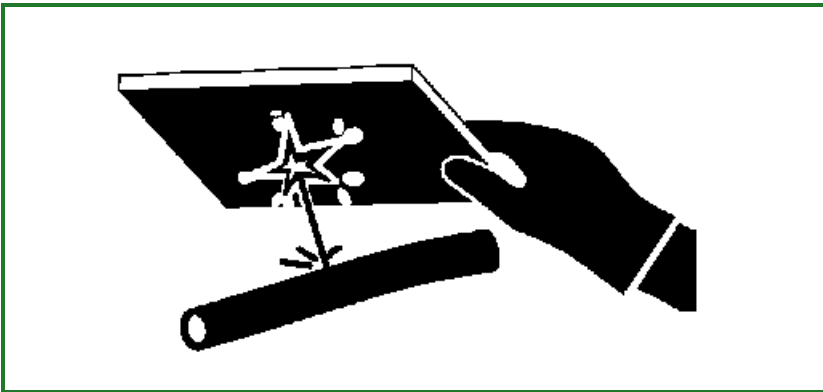

T133840-UN: Avoid High-Pressure Fluids

This machine uses a high-pressure hydraulic system. Escaping fluid under pressure can penetrate the skin causing serious injury.

Never search for leaks with your hands. Protect hands. Use a piece of cardboard to find location of escaping fluid. Stop engine and relieve pressure before disconnecting lines or working on hydraulic system.

If hydraulic fluid penetrates your skin, see a doctor immediately. Injected fluid must be removed surgically within hours or gangrene may result. Contact a knowledgeable medical source or the Deere & Company Medical Department in Moline, Illinois, U.S.A.

Go to [Section_00:Group_01](#)

TX03679,00016D3-19-20060907

Beware of Exhaust Fumes

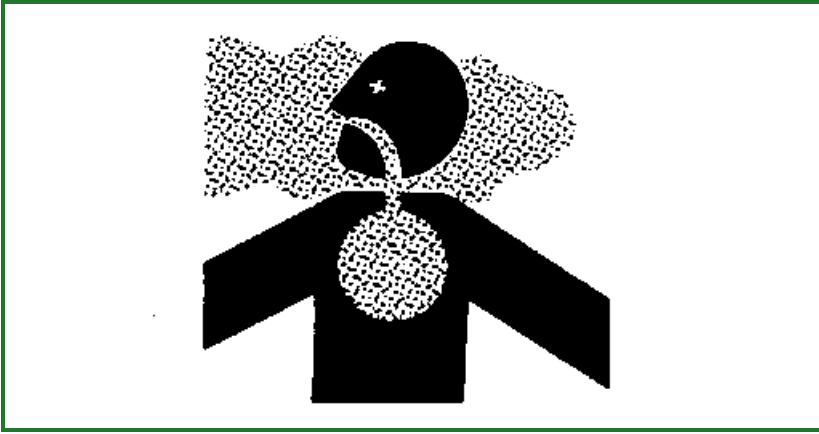

T133546-UN: Beware of Exhaust Fumes

Prevent asphyxiation. Engine exhaust fumes can cause sickness or death.

If you must operate in an enclosed space, provide adequate ventilation. Use an exhaust pipe extension to remove the exhaust fumes or open doors and windows to bring outside air into the area.

Go to [Section_00:Group_01](#)

TX03679,00016D4-19-20080623

Prevent Fires



T133552-UN: Handle Fuel Safely



T133553-UN: Clean Machine Regularly



T133554-UN: Carry A Fire Extinguisher

Handle Fuel Safely: Store flammable fluids away from fire hazards. Never refuel machine while smoking or when near sparks or flame.

Clean Machine Regularly: Keep trash, debris, grease and oil from accumulating in engine compartment, around fuel lines, hydraulic lines, exhaust components and electrical wiring. Never store oily rags or flammable materials inside a machine compartment.

Maintain Hoses and Wiring: Replace hydraulic hoses immediately if they begin to leak, and clean up any oil spills. Examine electrical wiring and connectors frequently for damage.

Keep A Fire Extinguisher Available: Always keep a multi-purpose fire extinguisher on or near the machine. Know how to use extinguisher properly.

Go to [Section_00:Group_01](#)

TX03679,00016F5-19-20090626

Prevent Battery Explosions



TS204-UN: Battery Explosions

Battery gas can explode. Keep sparks, lighted matches, and open flame away from the top of battery.

Never check battery charge by placing a metal object across the posts. Use a voltmeter or hydrometer.

Do not charge a frozen battery; it may explode. Warm battery to 16°C (60°F).

Go to [Section_00:Group_01](#)

TX03679,000174A-19-20080108

Handle Chemical Products Safely



T133580-UN: Handle Chemical Products Safely

Exposure to hazardous chemicals can cause serious injury. Under certain conditions, lubricants, coolants, paints and adhesives used with this machine may be hazardous.

If uncertain about safe handling or use of these chemical products, contact your authorized dealer for a Material Safety Data Sheet (MSDS) or go to internet website <http://www.jdmsds.com>. The MSDS describes physical and health hazards, safe use procedures, and emergency response techniques for chemical substances. Follow MSDS recommendations to handle chemical products safely.

Go to [Section_00:Group_01](#)

TX03679,00016D7-19-20070103

Dispose of Waste Properly

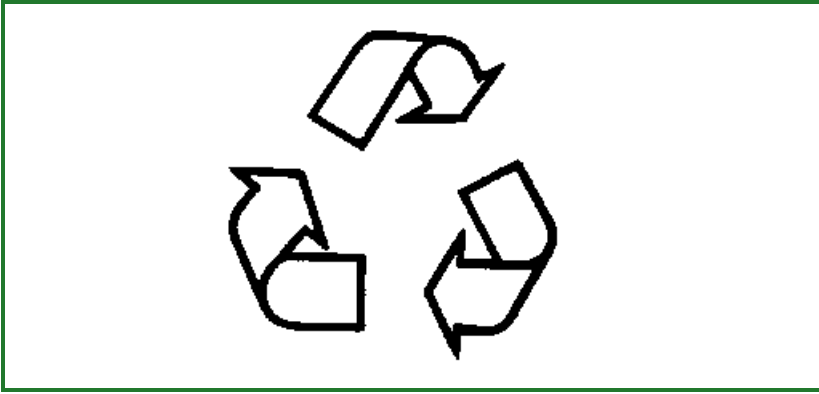

T133567-UN: Dispose of Waste Properly

Improper disposal of waste can threaten the environment. Fuel, oils, coolants, filters and batteries used with this machine may be harmful if not disposed of properly.

Never pour waste onto the ground, down a drain, or into any water source.

Air conditioning refrigerants can damage the atmosphere. Government regulations may require using a certified service center to recover and recycle used refrigerants.

If uncertain about the safe disposal of waste, contact your local environmental or recycling center or your authorized dealer for more information.

Go to [Section_00:Group_01](#)

TX03679,0001733-19-20080108

Prepare for Emergencies

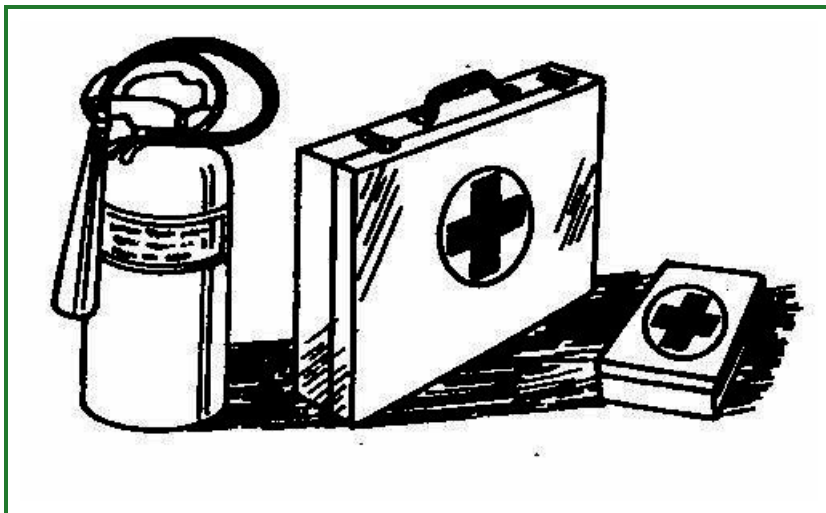

TS291-UN: First Aid Kit

Be prepared if an emergency occurs or a fire starts.

Keep a first aid kit and fire extinguisher handy.

Keep emergency numbers for doctors, ambulance service, hospital, and fire department near your telephone.

Go to [Section_00:Group_01](#)

TX03679,000174B-19-20080108

Add Cab Guarding For Special Uses

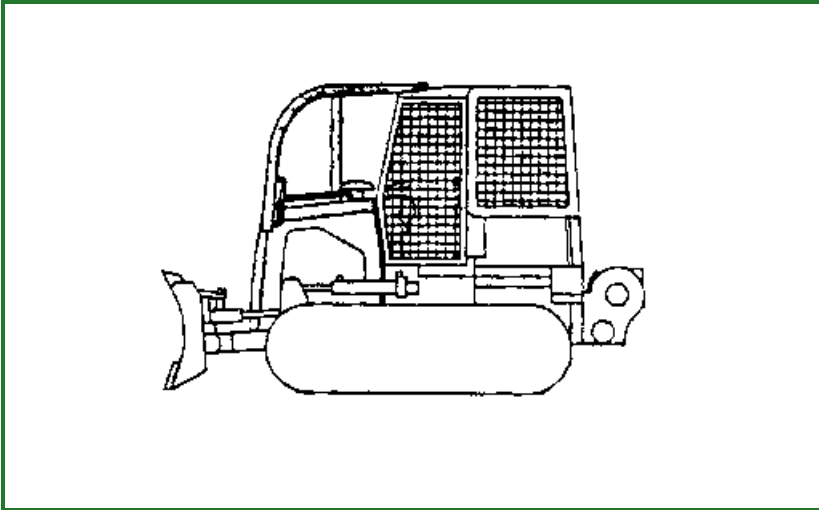

T139005-UN: Cab Guarding

Special work situations or machine attachments may expose the operator to intruding or flying objects. Using this machine in a forestry application or woods environment, or with attachments such as a winch, requires added guarding to protect the operator.

Forestry protection packages or special screens should be installed when working in areas where logs or branches may strike the operator. A rear screen should always be used with a winch to protect against a snapping cable. Contact your authorized dealer for information on protective guarding before operating in any hazardous environment.

Go to [Section_00:Group_01](#)

TX03768,0000B77-19-20080114

Start Only From Operator's Seat



T133715-UN: Operate Only From Operators Seat

Avoid unexpected machine movement. Before starting engine, sit in operator's seat. Ensure park lock lever is in "lock" position.

Never attempt to start engine from the ground or tracks. Do not attempt to start engine by shorting across the starter solenoid terminals.

Go to [Section_00:Group_01](#)

TX03768,0000B71-19-20010223

Prevent Unintended Machine Movement

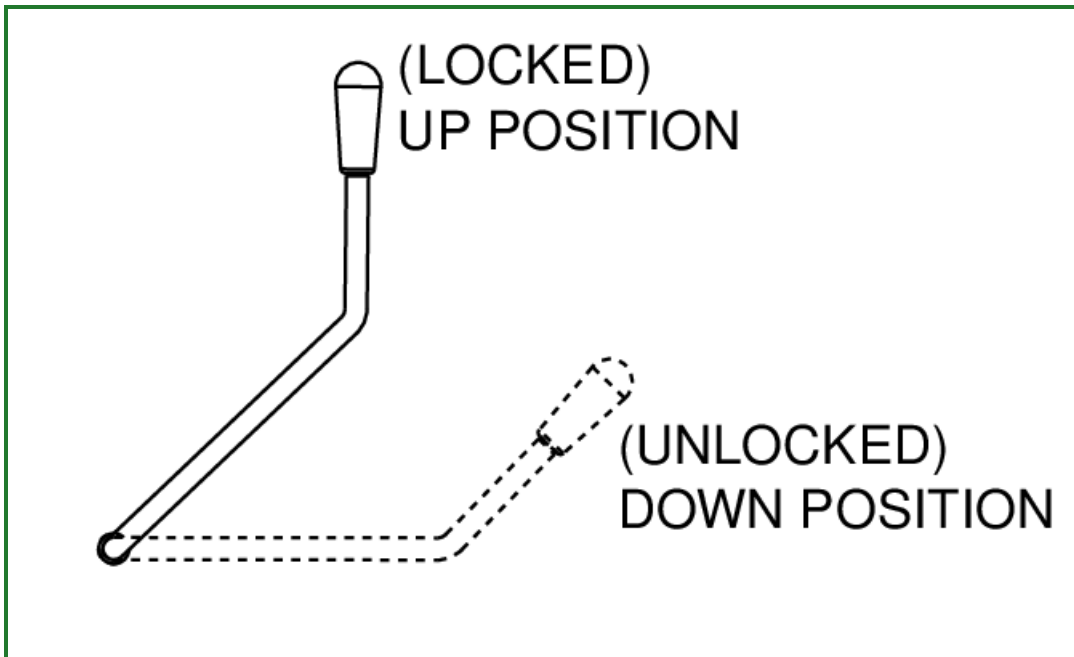

T159027-19: Locked Position

Always move the park lock lever to the “lock” position before leaving the operator's seat for any reason .

Be careful not to accidentally actuate controls when co-workers are present. Engage park lock and lower work equipment to the ground during work interruptions. Stop the engine before allowing anyone to approach the machine. Follow these same precautions before standing up, leaving the operator's seat, or exiting the machine.

Go to [Section_00:Group_01](#)

TX03768,0000B72-19-20010501

Avoid Work Site Hazards



T139002-UN: Avoid Work Site Hazards

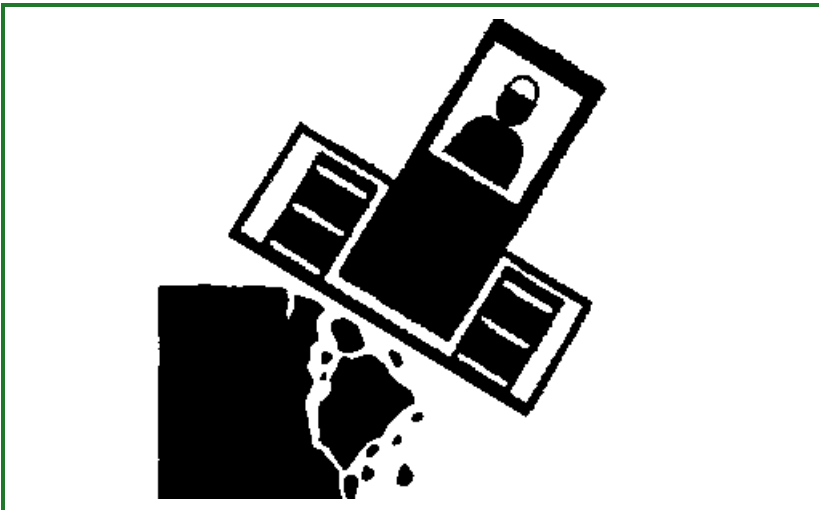

T139003-UN: Avoid Work Site Hazards

Avoid contact with gas lines, buried cables and water lines. Call utility line location services to identify all underground utilities before working below ground level.

Avoid or correct hazardous work situations. Avoid operating near structures or objects that could fall onto the machine. Clear away debris that could move unexpectedly if run over.

Keep bystanders clear at all times. Use barricades or a signal person to keep vehicles and pedestrians away. Always keep signal person in view. Instruct co-workers and bystanders not to approach the machine while it is operating.

Operate only on solid footing Use extra care when operating on stockpiles or near banks or excavations that may cave in and cause machine to tip or fall. Never allow the machine on a floor or structure until you are sure it will support the weight.

Avoid contact with overhead electrical wires. Stay clear of electrical lines. Never move any part of machine or load closer than 3 m (10 ft.) plus twice the line insulator length to overhead wires.

Keep Riders Off Machine

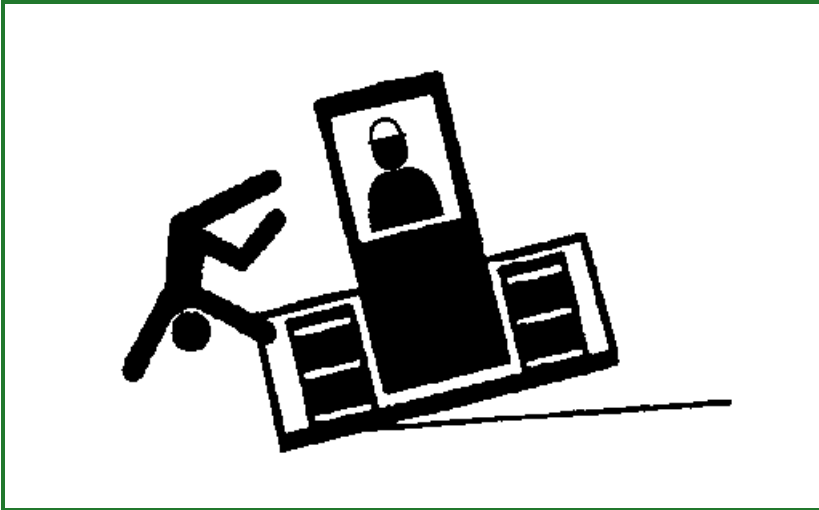

T137580-UN: Keep Riders Off Machine

Only allow operator on machine.

Riders are subject to injury. They may fall from machine, be caught between machine parts, or be struck by foreign objects.

Riders may obstruct operator's view or impair the operator's ability to operate machine safely.

[Go to Section_00:Group_01](#)

TX03768,0000B73-19-20150603

Avoid Backover Accidents



T138441-UN: Backover Warning

Before moving machine, be sure all persons are clear of the machine path. Turn around and look directly for best visibility. Use mirror to assist in checking behind the machine. Keep windows and mirror clean and in good repair.

Be certain backup warning alarm is working properly.

Use a signal person when backing if view is obstructed or when in close quarters. Keep signal person in view at all times. Use prearranged hand signals to communicate.

Go to [Section_00:Group_01](#)

TX03768,0000B69-19-20110614

Avoid Machine Tip Over



T133716-19: Avoid Machine Tip Over

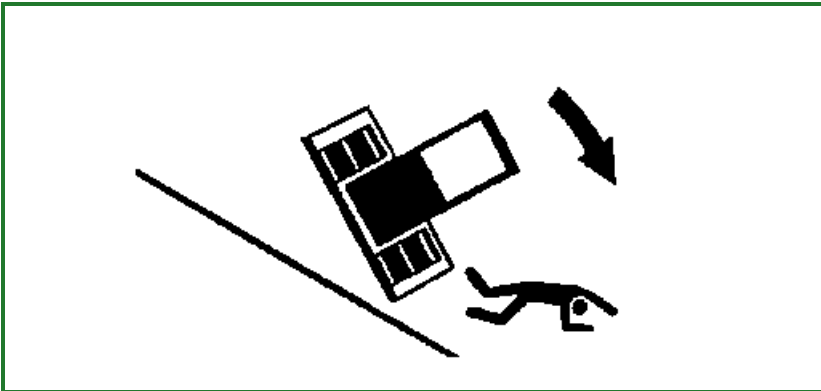

T138416-UN: Avoid Machine Tip Over

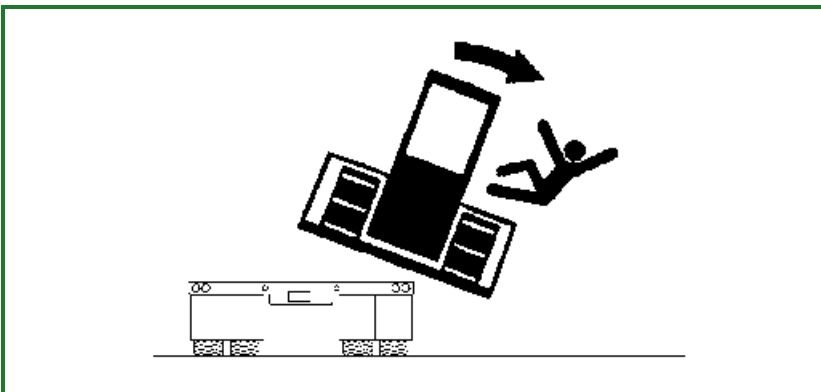

T138415-UN: Avoid Machine Tip Over

Use seat belt at all times.

Do not jump if the machine tips. You will be unlikely to jump clear and the machine may crush you.

Load and unload from trucks or trailers carefully. Be sure truck is wide enough and secured on a firm level surface. Use loading ramps and attach them properly to truck bed. Avoid trucks with steel beds because tracks slip more easily on steel.

Be careful on slopes. Use extra care on soft, rocky or frozen ground because machine may slip sideways in these conditions. When traveling up or down steep slopes, keep the bucket or blade on uphill side and just above ground level.

Ensure solid footing. Use extra care when operating on stockpile materials, or near banks or excavations that may cave-in and cause machine to tip or fall.

[Go to Section_00:Group_01](#)

TX03768,0000B6B-19-20081103

Park And Prepare For Service Safely



T133332-19: Do Not Operate Tag

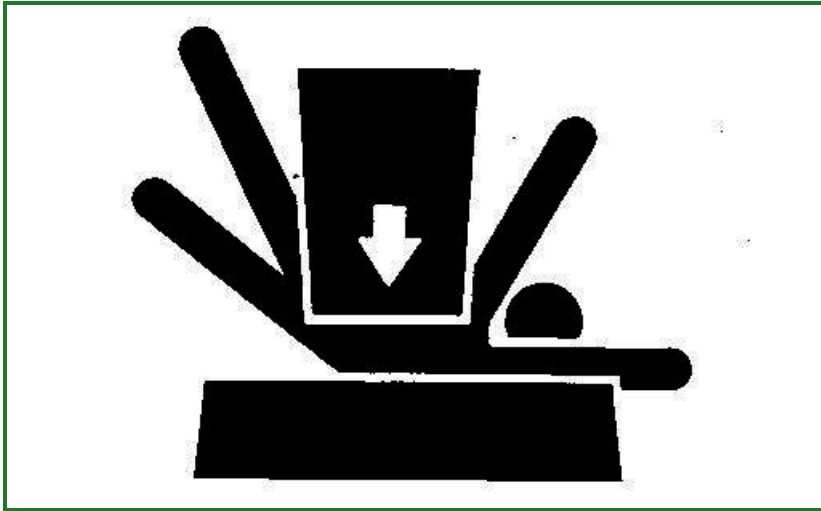

TS229-UN: Support Machine Properly

Warn others of service work. Always park and prepare your machine for service or repair properly.

- Park machine on a level surface and lower blade/bucket and attachments to the ground.
- Place park lock lever in “lock” position. Stop engine and remove key.
- Attach a “Do Not Operate” tag in an obvious place in the operator's station.

Securely support machine or attachment before working under it.

- Do not support machine with blade/bucket or attachments.
- Do not support machine with cinder blocks or wooden pieces that may crumble or crush.
- Do not support machine with a single jack or other devices that may slip out of place.

Understand service procedures before beginning repairs. Keep service area clean and dry. Use two people whenever the engine must be running for service work.

Go to [Section_00:Group_01](#)

TX03768,0000B6A-19-20091019

Service Cooling System Safely



TS281-UN: Cooling System

Explosive release of fluids from pressurized cooling system can cause serious burns.

Shut off engine. Only remove filler cap when cool enough to touch with bare hands. Slowly loosen cap to first stop to relieve pressure before removing completely.

Go to [Section_00:Group_01](#)

DX,RCAP-19-19900604

Remove Paint Before Welding or Heating

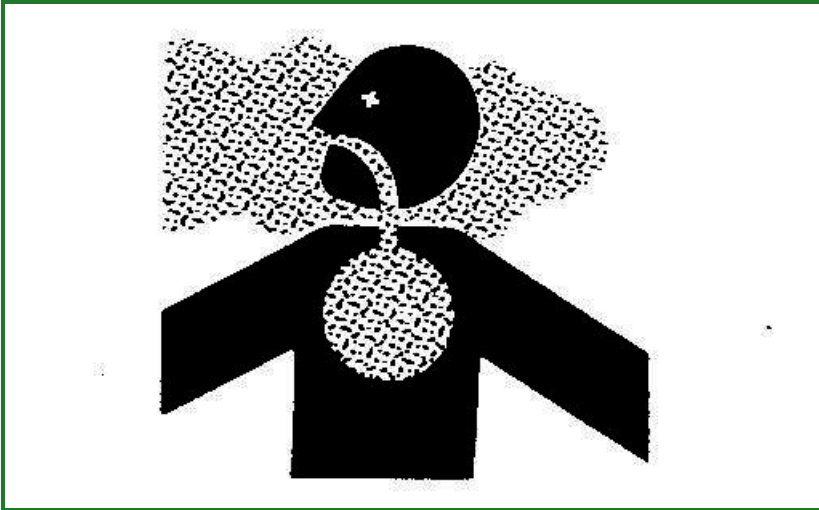

TS220-UN: Toxic Fumes

Avoid potentially toxic fumes and dust.

Hazardous fumes can be generated when paint is heated by welding, soldering, or using a torch.

Remove paint before heating:

- Remove paint a minimum of 100 mm (4 in.) from area to be affected by heating. If paint cannot be removed, wear an approved respirator before heating or welding.
- If you sand or grind paint, avoid breathing the dust. Wear an approved respirator.
- If you use solvent or paint stripper, remove stripper with soap and water before welding. Remove solvent or paint stripper containers and other flammable material from area. Allow fumes to disperse at least 15 minutes before welding or heating.

Do not use a chlorinated solvent in areas where welding will take place.

Do all work in an area that is well ventilated to carry toxic fumes and dust away.

Dispose of paint and solvent properly.

Go to [Section_00:Group_01](#)

DX,PAINT-19-20020724

Make Welding Repairs Safely

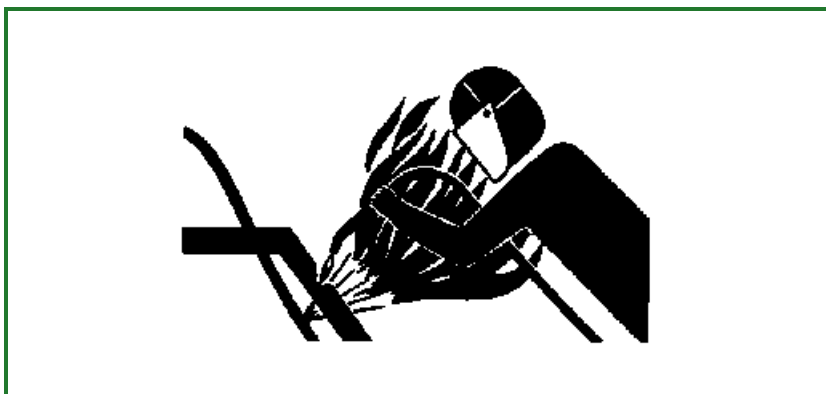

T133547-UN: Avoid Heating Near Pressurized Fluid Lines

IMPORTANT:

Disable electrical power before welding. Turn off main battery switch or disconnect positive battery cable. Separate harness connectors to engine and vehicle microprocessors.

Avoid welding or heating near pressurized fluid lines. Flammable spray may result and cause severe burns if pressurized lines fail as a result of heating. Do not let heat go beyond work area to nearby pressurized lines.

Remove paint properly. Do not inhale paint dust or fumes. Use a qualified welding technician for structural repairs. Make sure there is good ventilation. Wear eye protection and protective equipment when welding.

Go to [Section_00:Group_01](#)

TX03679,00016D5-19-20090911

Drive Metal Pins Safely

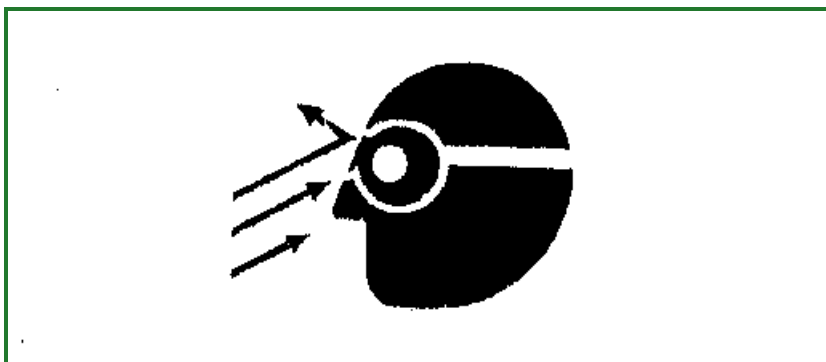

T133738-UN: Hardened Metal Parts

Always wear protective goggles or safety glasses and other protective equipment before striking hardened parts. Hammering hardened metal parts such as pins and bucket teeth may dislodge chips at high velocity.

Use a soft hammer or a brass bar between hammer and object to prevent chipping.

[Go to Section_00:Group_01](#)

OUO1065,0000090-19-20160106

Metric Bolt and Cap Screw Torque Values

-: Metric Bolt and Cap Screw Torque Values

METRIC BOLT AND CAP SCREW TORQUE VALUES—Tolerance is $\pm 10\%$ unless otherwise specified								
TORQ2-UN: Top—Property Class and Head Markings; Bottom—Property Class and Nut Markings								
	Class 4.8		Class 8.8 or 9.8		Class 10.9		Class 12.9	
Thread Size	Lubricated ^a Nm (lb-ft)	Dry ^b Nm (lb-ft)	Lubricated ^a Nm (lb-ft)	Dry ^b Nm (lb-ft)	Lubricated ^a Nm (lb-ft)	Dry ^b Nm (lb-ft)	Lubricated ^a Nm (lb-ft)	Dry ^b Nm (lb-ft)
M6	4.7 (3.5)	6 (4.4)	9 (6.6)	11.5 (8.5)	13 (9.5)	16.5 (12.2)	15.5 (11.5)	19.5 (14.5)
M8	11.5 (8.5)	14.5 (10.7)	22 (16)	28 (20.5)	32 (23.5)	40 (29.5)	37 (27.5)	47 (35)
M10	23 (17)	29 (21)	43 (32)	55 (40)	63 (46)	80 (59)	75 (55)	95 (70)
M12	40 (29.5)	50 (37)	75 (55)	95 (70)	110 (80)	140 (105)	130 (95)	165 (120)
M14	63 (46)	80 (59)	120 (88)	150 (110)	175 (130)	220 (165)	205 (150)	260 (190)
M16	100 (74)	125 (92)	190 (140)	240 (175)	275 (200)	350 (255)	320 (235)	400 (300)
M18	135 (100)	170 (125)	265 (195)	330 (245)	375 (275)	475 (350)	440 (325)	560 (410)
M20	190 (140)	245 (180)	375 (275)	475 (350)	530 (390)	675 (500)	625 (460)	790 (580)
M22	265 (195)	330 (245)	510 (375)	650 (480)	725 (535)	920 (680)	850 (625)	1080 (800)
M24	330 (245)	425 (315)	650 (480)	820 (600)	920 (680)	1150 (850)	1080 (800)	1350 (1000)
M27	490 (360)	625 (460)	950 (700)	1200 (885)	1350 (1000)	1700 (1250)	1580 (1160)	2000 (1475)
M30	660 (490)	850 (625)	1290 (950)	1630 (1200)	1850 (1350)	2300 (1700)	2140 (1580)	2700 (2000)
M33	900 (665)	1150 (850)	1750 (1300)	2200 (1625)	2500 (1850)	3150 (2325)	2900 (2150)	3700 (2730)

METRIC BOLT AND CAP SCREW TORQUE VALUES—Tolerance is ±10% unless otherwise specified

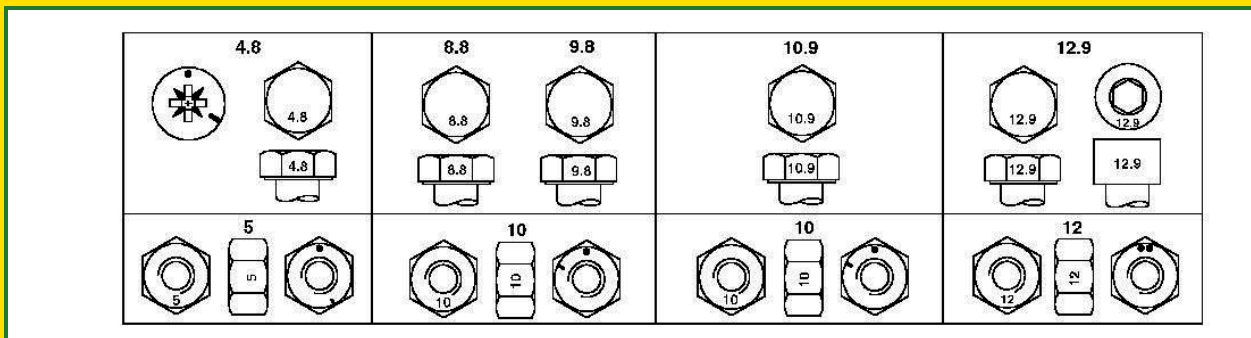

TORQ2-UN: Top—Property Class and Head Markings; Bottom—Property Class and Nut Markings

	Class 4.8		Class 8.8 or 9.8		Class 10.9		Class 12.9	
Thread Size	Lubricated ^a Nm (lb-ft)	Dry ^b Nm (lb-ft)	Lubricated ^a Nm (lb-ft)	Dry ^b Nm (lb-ft)	Lubricated ^a Nm (lb-ft)	Dry ^b Nm (lb-ft)	Lubricated ^a Nm (lb-ft)	Dry ^b Nm (lb-ft)
M36	1150 (850)	1450 (1075)	2250 (1650)	2850 (2100)	3200 (2350)	4050 (3000)	3750 (2770)	4750 (3500)

^a"Lubricated" means coated with a lubricant such as engine oil, or fasteners with phosphate and oil coatings.

^b"Dry" means plain or zinc plated without any lubrication.

-: Metric Bolt and Cap Screw Torque Value Instructions

⚠ CAUTION:

Use only metric tools on metric hardware. Other tools may not fit properly. Tool may slip and cause injury.

DO NOT use these values if a different torque value or tightening procedure is given for a specific application. Torque values listed are for general use only. Check tightness of fasteners periodically.

Shear bolts are designed to fail under predetermined loads. Always replace shear bolts with identical property class.

Fasteners should be replaced with the same or higher property class. If higher property class fasteners are used, these should only be tightened to the strength of the original.

Make sure fastener threads are clean and that you properly start thread engagement. This will prevent them from failing when tightening.

Tighten plastic insert or crimped steel-type lock nuts to approximately 50 percent of the dry torque shown in the chart, applied to the nut, not to the bolt head. Tighten toothed or serrated-type lock nuts to the full torque value.

Go to [Section_00:Group_03](#)

OUT3035,TORQUE2-19-20040322

Metric Bolt and Cap Screw Torque Values

-: Metric Bolt and Cap Screw Torque Values

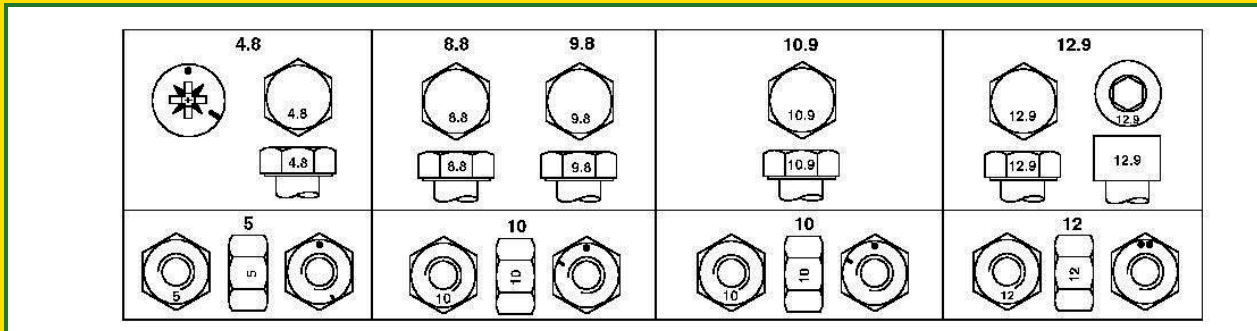
METRIC BOLT AND CAP SCREW TORQUE VALUES—Tolerance is $\pm 10\%$ unless otherwise specified

TORQ2-UN: Top—Property Class and Head Markings; Bottom—Property Class and Nut Markings

Thread Size	Class 4.8		Class 8.8 or 9.8		Class 10.9		Class 12.9	
	Lubricated ^a Nm (lb-ft)	Dry ^b Nm (lb-ft)	Lubricated ^a Nm (lb-ft)	Dry ^b Nm (lb-ft)	Lubricated ^a Nm (lb-ft)	Dry ^b Nm (lb-ft)	Lubricated ^a Nm (lb-ft)	Dry ^b Nm (lb-ft)
M6	4.7 (3.5)	6 (4.4)	9 (6.6)	11.5 (8.5)	13 (9.5)	16.5 (12.2)	15.5 (11.5)	19.5 (14.5)
M8	11.5 (8.5)	14.5 (10.7)	22 (16)	28 (20.5)	32 (23.5)	40 (29.5)	37 (27.5)	47 (35)
M10	23 (17)	29 (21)	43 (32)	55 (40)	63 (46)	80 (59)	75 (55)	95 (70)
M12	40 (29.5)	50 (37)	75 (55)	95 (70)	110 (80)	140 (105)	130 (95)	165 (120)
M14	63 (46)	80 (59)	120 (88)	150 (110)	175 (130)	220 (165)	205 (150)	260 (190)
M16	100 (74)	125 (92)	190 (140)	240 (175)	275 (200)	350 (255)	320 (235)	400 (300)
M18	135 (100)	170 (125)	265 (195)	330 (245)	375 (275)	475 (350)	440 (325)	560 (410)
M20	190 (140)	245 (180)	375 (275)	475 (350)	530 (390)	675 (500)	625 (460)	790 (580)
M22	265 (195)	330 (245)	510 (375)	650 (480)	725 (535)	920 (680)	850 (625)	1080 (800)
M24	330 (245)	425 (315)	650 (480)	820 (600)	920 (680)	1150 (850)	1080 (800)	1350 (1000)
M27	490 (360)	625 (460)	950 (700)	1200 (885)	1350 (1000)	1700 (1250)	1580 (1160)	2000 (1475)
M30	660 (490)	850 (625)	1290 (950)	1630 (1200)	1850 (1350)	2300 (1700)	2140 (1580)	2700 (2000)
M33	900 (665)	1150 (850)	1750 (1300)	2200 (1625)	2500 (1850)	3150 (2325)	2900 (2150)	3700 (2730)

METRIC BOLT AND CAP SCREW TORQUE VALUES—Tolerance is ±10% unless otherwise specified

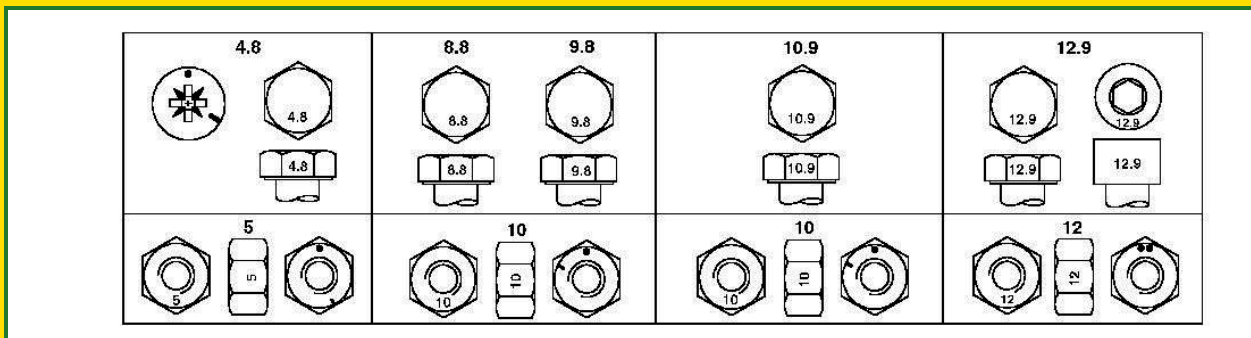

TORQ2-UN: Top—Property Class and Head Markings; Bottom—Property Class and Nut Markings

	Class 4.8		Class 8.8 or 9.8		Class 10.9		Class 12.9	
Thread Size	Lubricated ^a Nm (lb-ft)	Dry ^b Nm (lb-ft)	Lubricated ^a Nm (lb-ft)	Dry ^b Nm (lb-ft)	Lubricated ^a Nm (lb-ft)	Dry ^b Nm (lb-ft)	Lubricated ^a Nm (lb-ft)	Dry ^b Nm (lb-ft)
M36	1150 (850)	1450 (1075)	2250 (1650)	2850 (2100)	3200 (2350)	4050 (3000)	3750 (2770)	4750 (3500)

^a"Lubricated" means coated with a lubricant such as engine oil, or fasteners with phosphate and oil coatings.

^b"Dry" means plain or zinc plated without any lubrication.

-: Metric Bolt and Cap Screw Torque Value Instructions

⚠ CAUTION:

Use only metric tools on metric hardware. Other tools may not fit properly. Tool may slip and cause injury.

DO NOT use these values if a different torque value or tightening procedure is given for a specific application. Torque values listed are for general use only. Check tightness of fasteners periodically.

Shear bolts are designed to fail under predetermined loads. Always replace shear bolts with identical property class.

Fasteners should be replaced with the same or higher property class. If higher property class fasteners are used, these should only be tightened to the strength of the original.

Make sure fastener threads are clean and that you properly start thread engagement. This will prevent them from failing when tightening.

Tighten plastic insert or crimped steel-type lock nuts to approximately 50 percent of the dry torque shown in the chart, applied to the nut, not to the bolt head. Tighten toothed or serrated-type lock nuts to the full torque value.

Go to [Section_00:Group_03](#)

OUT3035,TORQUE2-19-20040322

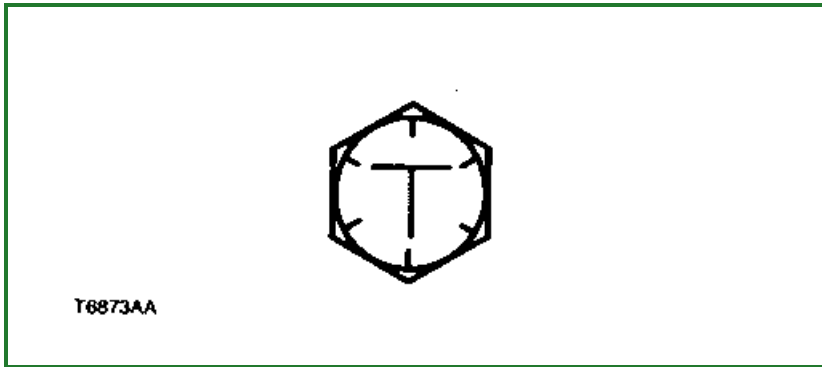
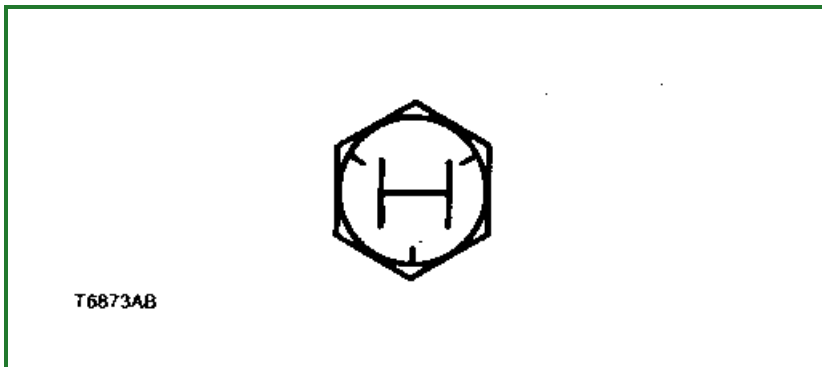
Additional Metric Cap Screw Torque Values**T6873AA-UN: T-Bolt****T6873AB-UN: H-Bolt****T6873AC-UN: M-Bolt****⚠ CAUTION:**

Use only metric tools on metric hardware. Other tools may not fit properly. They may slip and cause injury.

Check tightness of cap screws periodically. Torque values listed are for general use only. Do not use these values if a different torque value or tightening procedure is listed for a specific application.

Shear bolts are designed to fail under predetermined loads. Always replace shear bolts with identical grade.

Fasteners should be replaced with the same or higher grade. If higher grade fasteners are used, these should only be tightened to the strength of the original.

Make sure fastener threads are clean and that the thread engagement is properly started. This will prevent fasteners from failing when tightening.

Tighten cap screws having lock nuts to approximately 50 percent of amount shown in chart.

-: Metric Cap Screw Torque Values

METRIC CAP SCREW TORQUE VALUES [Torque tolerance is ±10%.]						
	T-Bolt		H-Bolt		M-Bolt	
Nominal Diameter	N·m	lb·ft	N·m	lb·ft	N·m	lb·ft
8	29	21	20	15	10	7
10	63	46	45	33	20	15
12	108	80	88	65	34	25
14	176	130	137	101	54	40
16	265	195	206	152	78	58
18	392	289	294	217	118	87
20	539	398	392	289	167	125
22	735	542	539	398	216	159
24	931	687	686	506	274	202
27	1372	1012	1029	759	392	289
30	1911	1410	1421	1049	539	398
33	2548	1890	1911	1410	735	542
36	3136	2314	2401	1772	931	687

Go to [Section_00:Group_03](#)

04T,90,M170-19-19990929

Unified Inch Bolt and Cap Screw Torque Values

-: Unified Inch Bolt and Cap Screw Torque Values

UNIFIED INCH BOLT AND CAP SCREW TORQUE VALUES—Tolerance is ±10% unless otherwise specified

TORQ1A-UN: Top—SAE Grade and Head Markings; Bottom—SAE Grade and Nut Markings

Thread Size	Grade 1 (No Mark)		Grade 2 ^a (No Mark)		Grade 5, 5.1 or 5.2		Grade 8 or 8.2	
	Lubricated ^b N·m (lb-ft)	Dry ^c N·m (lb-ft)	Lubricated ^b N·m (lb-ft)	Dry ^c N·m (lb-ft)	Lubricated ^b N·m (lb-ft)	Dry ^c N·m (lb-ft)	Lubricated ^b N·m (lb-ft)	Dry ^c N·m (lb-ft)
1/4	3.8 (2.8)	4.7 (3.5)	6 (4.4)	7.5 (5.5)	9.5 (7)	12 (9)	13.5 (10)	17 (12.5)
5/16	7.7 (5.7)	9.8 (7.2)	12 (9)	15.5 (11.5)	19.5 (14.5)	25 (18.5)	28 (20.5)	35 (26)
3/8	13.5 (10)	17.5 (13)	22 (16)	27.5 (20)	35 (26)	44 (32.5)	49 (36)	63 (46)
7/16	22 (16)	28 (20.5)	35 (26)	44 (32.5)	56 (41)	70 (52)	80 (59)	100 (74)
1/2	34 (25)	42 (31)	53 (39)	67 (49)	85 (63)	110 (80)	120 (88)	155 (115)
9/16	48 (35.5)	60 (45)	76 (56)	95 (70)	125 (92)	155 (115)	175 (130)	220 (165)
5/8	67 (49)	85 (63)	105 (77)	135 (100)	170 (125)	215 (160)	240 (175)	305 (225)
3/4	120 (88)	150 (110)	190 (140)	240 (175)	300 (220)	380 (280)	425 (315)	540 (400)
7/8	190 (140)	240 (175)	190 (140)	240 (175)	490 (360)	615 (455)	690 (510)	870 (640)
1	285 (210)	360 (265)	285 (210)	360 (265)	730 (540)	920 (680)	1030 (760)	1300 (960)
1-1/8	400 (300)	510 (375)	400 (300)	510 (375)	910 (670)	1150 (850)	1450 (1075)	1850 (1350)
1-1/4	570 (420)	725 (535)	570 (420)	725 (535)	1280 (945)	1630 (1200)	2050 (1500)	2600 (1920)

UNIFIED INCH BOLT AND CAP SCREW TORQUE VALUES—Tolerance is ±10% unless otherwise specified

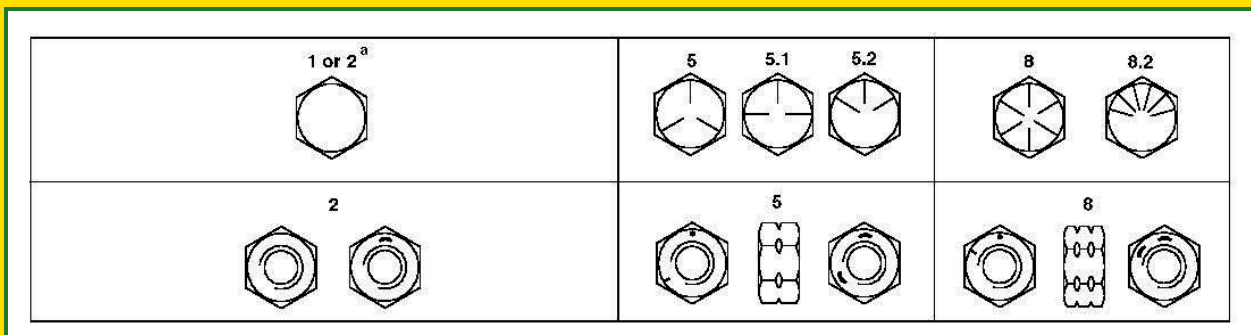

TORQ1A-UN: Top—SAE Grade and Head Markings; Bottom—SAE Grade and Nut Markings

Thread Size	Grade 1 (No Mark)		Grade 2 ^a (No Mark)		Grade 5, 5.1 or 5.2		Grade 8 or 8.2	
	Lubricated ^b N·m (lb-ft)	Dry ^c N·m (lb-ft)	Lubricated ^b N·m (lb-ft)	Dry ^c N·m (lb-ft)	Lubricated ^b N·m (lb-ft)	Dry ^c N·m (lb-ft)	Lubricated ^b N·m (lb-ft)	Dry ^c N·m (lb-ft)
1-3/8	750 (550)	950 (700)	750 (550)	950 (700)	1700 (1250)	2140 (1580)	2700 (2000)	3400 (2500)
1-1/2	990 (730)	1250 (930)	990 (730)	1250 (930)	2250 (1650)	2850 (2100)	3600 (2650)	4550 (3350)

^aGrade 2 applies for hex cap screws (not hex bolts) up to 6 in. (152 mm) long. Grade 1 applies for hex cap screws over 6 in. (152 mm) long, and for all other types of bolts and screws of any length.

^b"Lubricated" means coated with a lubricant such as engine oil, or fasteners with phosphate and oil coatings.

^c"Dry" means plain or zinc plated without any lubrication.

-: Unified Inch Bolt and Cap Screw Torque Value Instructions

DO NOT use these values if a different torque value or tightening procedure is given for a specific application. Torque values listed are for general use only. Check tightness of fasteners periodically. Shear bolts are designed to fail under predetermined loads. Always replace shear bolts with identical grade. Fasteners should be replaced with the same or higher grade. If higher grade fasteners are used, these should only be tightened to the strength of the original.

Make sure fastener threads are clean and that you properly start thread engagement. This will prevent them from failing when tightening.

Tighten plastic insert or crimped steel-type lock nuts to approximately 50 percent of the dry torque shown in the chart, applied to the nut, not to the bolt head. Tighten toothed or serrated-type lock nuts to the full torque value.

Go to [Section_00:Group_03](#)

OUT3035,TORQUE1-19-20040114

Service Recommendations for 37° Flare and 30° Cone Seat Connectors

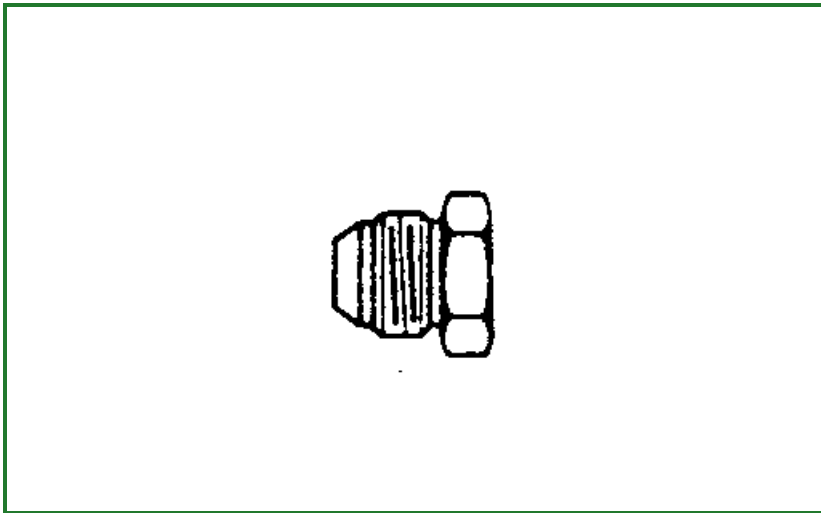

T6234AC-UN: Cone Seat Connector

1. Inspect flare and flare seat. They must be free of dirt or obvious defects.
2. Defects in tube flare cannot be repaired. Overtightening a defective flared fitting will not stop leaks.
3. Align tube with fitting before attempting to start nut.
4. Lubricate male threads with hydraulic fluid or petroleum jelly.
5. Index angle fittings and tighten by hand.
6. Tighten fitting or nut to torque value shown on torque chart. Do not allow hoses to twist when tightening fittings.

-: Straight Fitting or Special Nut Torque Chart

STRAIGHT FITTING OR SPECIAL NUT TORQUE CHART		
Thread Size	N·m	lb·ft
3/8 - 24 UNF	8	6
7/16 - 20 UNF	12	9
1/2 - 20 UNF	16	12
9/16 - 18 UNF	24	18
3/4 - 16 UNF	46	34
7/8 - 14 UNF	62	46
1-1/16 - 12 UN	102	75
1-3/16 - 12 UN	122	90
1-5/16 - 12 UN	142	105
1-5/8 - 12	190	140
1-7/8 - 12 UN	217	160

NOTE:

Torque tolerance is $\pm 10\%$.

Go to [Section_00:Group_03](#)

T82,BHMA,EL-19-19990929

Service Recommendations for O-Ring Boss Fittings

Straight Fitting

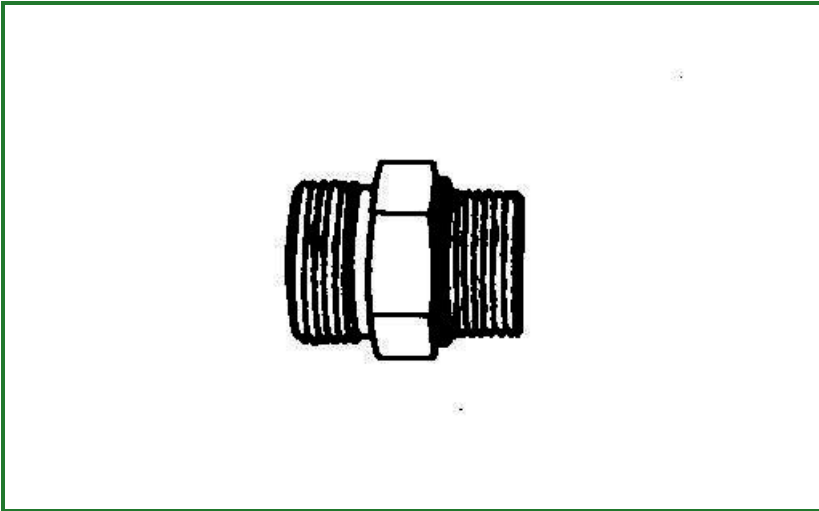

T6243AE-UN: Straight Fitting

1. Inspect O-ring boss seat for dirt or defects.
2. Lubricate O-ring with petroleum jelly. Place electrical tape over threads to protect O-ring. Slide O-ring over tape and into O-ring groove of fitting. Remove tape.
3. Tighten fitting to torque value shown on chart.

Angle Fitting

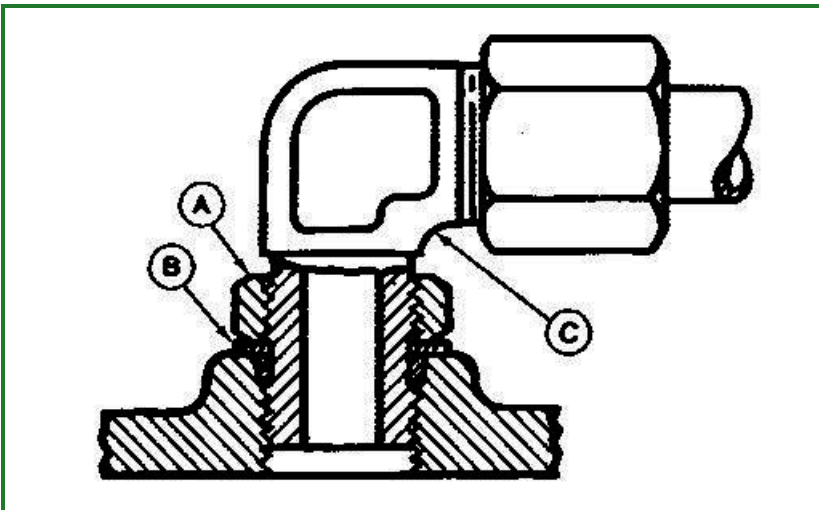

T6520AB-UN: Angle Fitting

LEGEND:

- A - Lock Nut
- B - Backup Washer
- C - Head End

1. Back off lock nut (A) and backup washer (B) completely to head end (C) of fitting.
2. Turn fitting into threaded boss until backup washer contacts face of boss.
3. Turn fitting head end counterclockwise to proper index (maximum of one turn).

4. **NOTE:**

Do not allow hoses to twist when tightening fittings.

Hold fitting head end with a wrench and tighten locknut and backup washer to proper torque value.

-: Straight Fitting or Special Nut Torque Chart

STRAIGHT FITTING OR SPECIAL NUT TORQUE CHART		
Thread Size	N·m	lb·ft
3/8-24 UNF	8	6
7/16-20 UNF	12	9
1/2-20 UNF	16	12
9/16-18 UNF	24	18
3/4-16 UNF	46	34
7/8-14 UNF	62	46
1-1/16-12 UN	102	75
1-3/16-12 UN	122	90
1-5/16-12 UN	142	105
1-5/8-12 UN	190	140
1-7/8-12 UN	217	160

NOTE:
Torque tolerance is ± 10%.

Go to [Section_00:Group_03](#)

04T,90,K66-19-19990929

O-Ring Boss Fittings In Aluminum Housing Service Recommendations—Excavators

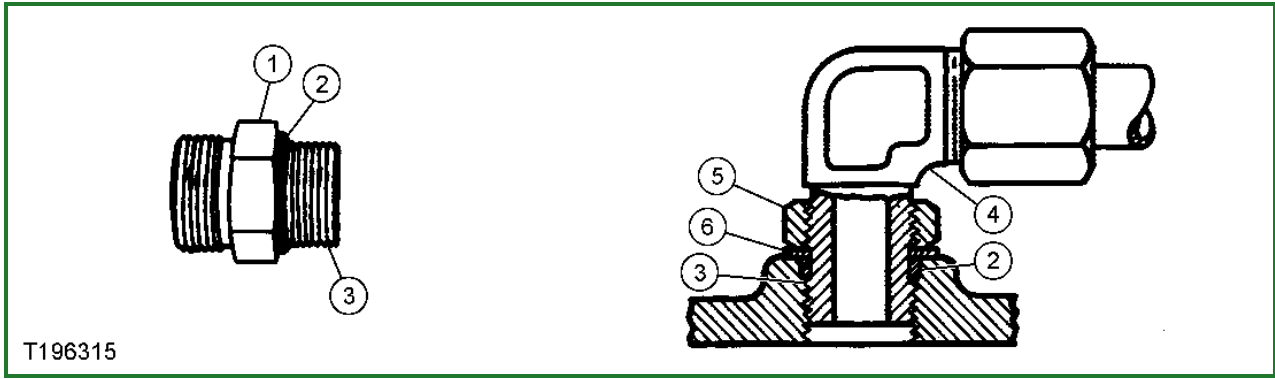

T196315-UN: O-Ring Boss Straight and Adjustable Fittings

LEGEND:

- 1 - Straight Fitting
- 2 - O-Ring
- 3 - Stud End
- 4 - Adjustable Fitting
- 5 - Hex Nut
- 6 - Backup Washer

-: Straight or Adjustable Fitting Stud End Nut with Metric Thread in Aluminum Housing Torque Values

O-RING BOSS STRAIGHT OR ADJUSTABLE FITTING STUD END NUT WITH METRIC THREAD IN ALUMINUM HOUSING TORQUE VALUES—Tolerance is ± 10% unless otherwise specified		
Thread Size mm	Hex Nut Size mm	Nm (lb-ft)
M12 x 1.5	17	39 (29)
M14 x 1.5	19	39 (29)
M16 x 1.5	22	55 (41)
M22 x 1.5	27	75 (55)
M27 x 2	32	110 (81)
M30 x 2	36	141 (104)
M33 x 2	41	165 (122)
M38 x 2	46	165 (122)
M42 x 2	50	275 (203)

-: Straight or Adjustable Fitting Stud End Nut with Inch Thread in Aluminum Housing Torque Values

O-RING BOSS STRAIGHT OR ADJUSTABLE FITTING STUD END NUT WITH INCH THREAD IN ALUMINUM HOUSING TORQUE VALUES—Tolerance is ± 10% unless otherwise specified	
Thread Size in.	Nm (lb-ft)
1/8	—

O-RING BOSS STRAIGHT OR ADJUSTABLE FITTING STUD END NUT WITH INCH THREAD IN ALUMINUM HOUSING TORQUE VALUES—Tolerance is $\pm 10\%$ unless otherwise specified

Thread Size in.	Nm (lb-ft)
1/4	28 (20)
3/8	39 (29)
1/2	75 (55)
3/4	126 (93)
1	165 (122)
1-1/8	—
1-1/4	259 (191)
1-3/8	—
1-1/2	330 (243)
1-3/4	—
2	—

:- O-Ring Boss Plug Stud End with Inch Thread in Aluminum Housing Torque Values**O-RING BOSS PLUG STUD END WITH INCH THREAD IN ALUMINUM HOUSING TORQUE VALUES—Tolerance is $\pm 10\%$ unless otherwise specified**

Thread Size in.	Nm (lb-ft)
1/8	7.8 (5.80)
1/4	11.8 (8.70)
3/8	23 (17)
1/2	39 (29)
3/4	55 (41)
1	86 (64)
1-1/4	126 (93)
1-1/2	157 (116)
2	204 (150)

1. Inspect fitting and O-ring boss sealing surfaces and the O-ring. They must be free of dirt, scratches, nicks, or burrs. O-ring must be free of dirt, cuts, cracks, swelling or flatten condition.
2. Back the stud end hex nut (5) off as far as possible. Push backup washer (6) towards the nut to fully expose the turn down section of stud end. Washer must fit turned down section and not be too loose
3. Wrap electrical tape over threads to protect O-ring. Slide O-ring over the tape into turned down section. Remove tape. Apply hydraulic oil to the threads of stud end, turned down section, and O-ring.
4. Turn fitting into the boss by hand until face of nut or backup washer squeezes O-ring into the seat and

contacts face of boss. Loosen an adjustable fitting no more than one turn for alignment.

5. Tighten straight fitting or hex nut to the torque value given. Hold body of adjustable fitting using a second wrench when tightening hex nut.

Go to [Section_00:Group_03](#)

OUT3035,0000353-19-20090528

Service Recommendations for Flared Connections—Straight or Tapered Threads

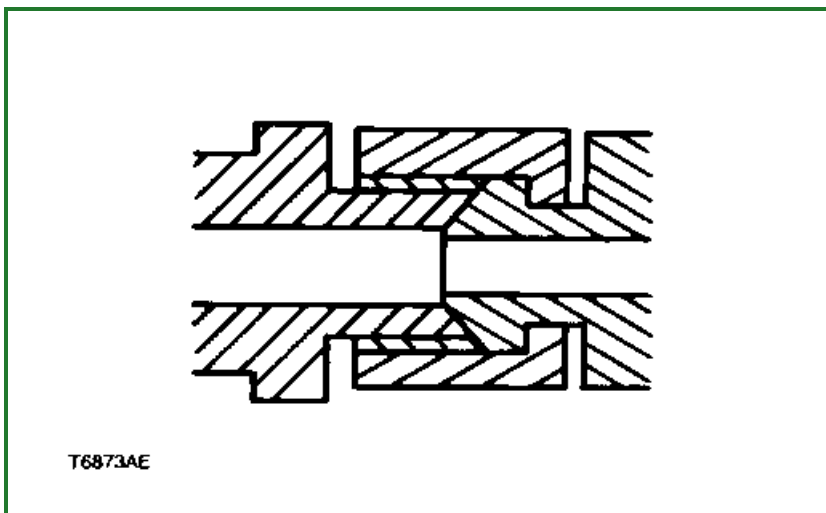

T6873AE-UN: Straight Thread

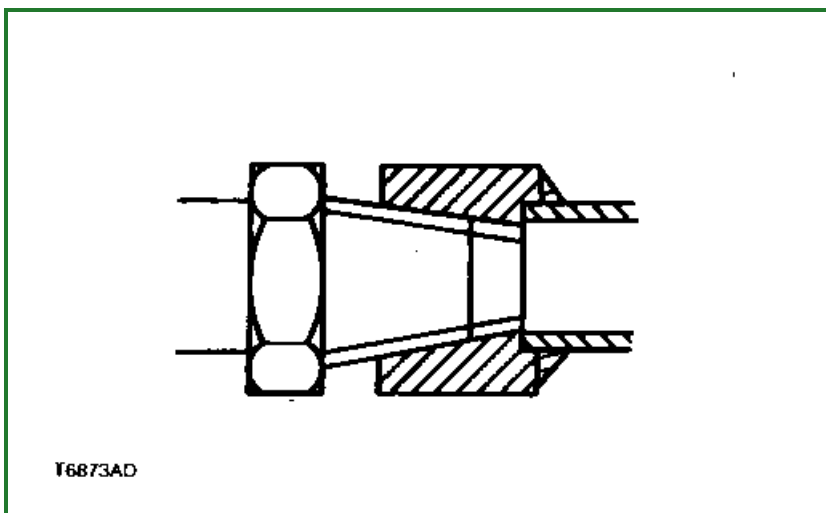

T6873AD-UN: Tapered Thread

1. Inspect flare and flare seat. They must be free of dirt or obvious defects.
2. Defects in the tube flare cannot be repaired. Overtightening a defective flared fitting will not stop leaks.
3. Align the tube with the fitting before attempting to start the nut.
4. Lubricate the male threads with hydraulic fluid or petroleum jelly.
5. Index angle fittings and tighten by hand.
6. Tighten fitting or nut to torque value shown on the chart. Do not allow hoses to twist when tightening fittings.

-: Torque Chart

TORQUE CHART [Torque tolerance is $\pm 10\%$.]				
	Straight Thread [With seat face.]		Tapered Thread	
Thread Size	N·m	lb·ft	N·m	lb·ft
1/8	15	11		

TORQUE CHART [Torque tolerance is $\pm 10\%$.]				
Thread Size	Straight Thread [With seat face.]		Tapered Thread	
	N·m	lb·ft	N·m	lb·ft
1/4	20	15	45	33
3/8	29	21	69	51
1/2	49	36	93	69
3/4	69	51	176	130
1	157	116	343	253
1-1/2	196	145	539	398
2	255	188	588	434

NOTE:

If female thread is cast iron (control valves, brake valves motors, etc.), torque must be reduced approximately 10%.

Go to [Section_00:Group_03](#)

04T,90,M171-19-19920128

Service Recommendations For Flat Face O-Ring Seal Fittings

1. Inspect the fitting sealing surfaces and O-ring. They must be free of dirt or defects.
2. Lubricate O-rings and install into groove using petroleum jelly to hold in place.
3. Index angle fittings and tighten by hand pressing joint together to insure O-ring remains in place.
4. Tighten fitting or nut to torque value shown on the chart. Do not allow hoses to twist when tightening fittings, use backup wrench on straight hose couplings.

IMPORTANT:

Tighten fittings to 150% of listed torque value if indexing is necessary or if fitting is attached to an actuating devise.

Tighten fittings to 50% of listed torque value if used in aluminum housing.

-: O-ring Seal Fitting Torque

FLAT FACE O-RING SEAL FITTING TORQUE*						
Nomial Tube O.D.		Thread Size	Swivel Nut		Bulkhead Nut	
mm	in.	in.	N·m	lb-ft	N·m	lb-ft
6.35	0.250	9/16-18	16	12	12	9
9.52	0.375	11/16-16	24	18	24	18
12.70	0.500	13/16-16	50	37	46	34
15.88	0.625	1-14	69	51	62	46
19.05	0.750	1 3/16-12	102	75	102	75
22.22	0.875	1 3/16-12	102	75	102	75
25.40	1.000	1 7/16-12	142	105	142	105
31.75	1.250	1 11/16-12	190	140	190	140
38.10	1.500	2-12	217	160	217	160

*Torque tolerance is +15 -20% unless otherwise specified.

Stud End O-ring Seal Torque for Straight and Adjustable Fittings*				
Thread Size	Straight Hex Size	Locknut Hex Size	Straight Fitting or Locknut Toque	
Inch	Inch	Inch	N·m	lb-ft
3/8-24	5/8	9/16	12	9
7/16-20	5/8	5/8	21	15
1/2-20	3/4	11/16	26	19
9/16-18	3/4	3/4	34	25
3/4-16	7/8	15/16	73	55
7/8-14	1 1/16	1 1/16	104	76
1 1/16-12	1 1/4	1 3/8	176	130

Service Recommendations For Flat Face O-Ring Seal Fittings

1 3/16-12	1 3/8	1 1/2	230	170
1 5/16-12	1 1/2	1 5/8	285	210
*Torque tolerance is +15 -20% unless otherwise specified.				

Go to [Section_00:Group_03](#)

04T,90,K67-19-20000302

O-Ring Face Seal Fittings With SAE Inch Hex Nut And Stud End For High Pressure Service Recommendations

-: O-Ring Face Seal Fittings with SAE Inch Hex Nut and Stud End for High Pressure Torque Values

O-RING FACE SEAL FITTINGS WITH SAE INCH HEX NUT AND STUD END FOR HIGH PRESSURE, ABOVE 27 600 kPa (276 bar) (4000 psi), TORQUE VALUES—Tolerance is +15 -20% unless otherwise specified

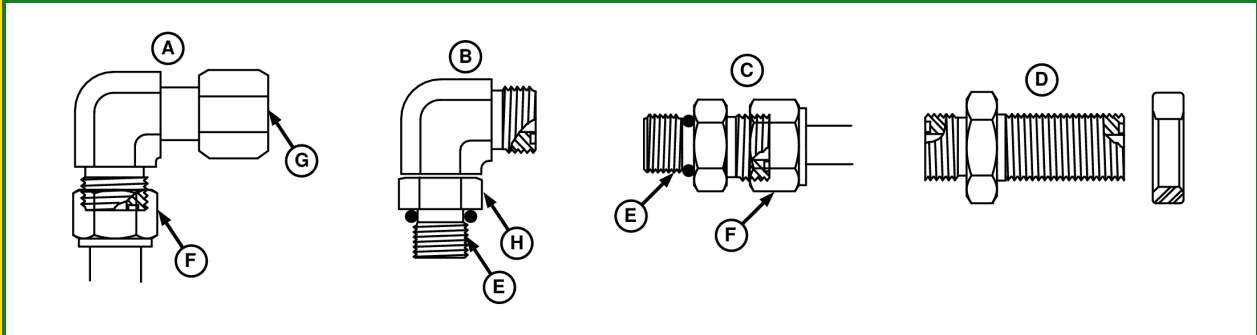

H70406-UN: O-Ring Face Seal Fitting

LEGEND:

- A - 90° Swivel Elbow and Tube Nut
- B - 90° Adjustable Stud Elbow
- C - Stud Straight and Tube Nut
- D - Bulkhead Union and Nut
- E - Stud End
- F - Tube Nut
- G - Swivel Nut
- H - Hex Nut

Nominal Tube OD or Hose ID			O-Ring Face Seal Hose or Tube Swivel Nut			Bulkhead Nut	
Metric Tube OD	Inch Tube OD or Hose ID		Thread Size	Hex Size	Torque	Hex Size	Torque
mm	Dash Size	mm (in.)	in.	in.	Nm (lb-ft)	in.	Nm (lb-ft)
5	-3	4.78 (0.188)	—	—	—	—	—
6	-4	6.35 (0.250)	9/16-18	11/16	24 (18)	13/16	32 (24)
8	-5	7.92 (0.312)	—	—	—	—	—
10	-6	9.53 (0.375)	11/16-16	13/16	37 (27)	1	42 (31)
12	-8	12.70 (0.500)	13/16-16	15/16	75 (55)	1-1/8	93 (69)
16	-10	15.88 (0.625)	1-14	1-1/8	103 (76)	1-5/16	118 (87)
20	-12	19.05 (0.750)	1-3/16-12	1-3/8	152 (112)	1-1/2	175 (129)
22	-14	22.23 (0.875)	1-3/16-12	—	152 (112)	—	175 (129)
25	-16	25.40 (1.000)	1-7/16-12	1-5/8	214 (158)	1-3/4	247 (182)
32	-20	31.75 (1.250)	1-11/16-12	1-7/8	286 (211)	2	328 (242)
38	-24	38.10 (1.500)	2-12	2-1/4	326 (240)	2-3/8	374 (276)

O-RING STRAIGHT, ADJUSTABLE, AND EXTERNAL HEX PLUG WITH SAE INCH STUD END FOR HIGH PRESSURE, ABOVE 27 600 kPa (276 bar) (4000 psi), TORQUE VALUES—Tolerance is +15 -20% unless otherwise specified			
Thread Size	Straight Hex Size^a	Adjustable Nut Hex Size	Steel or Gray Iron Torque
in.	in.	in.	Nm (lb-ft)
3/8-24	5/8	9/16	18 (13)
7/16-20	5/8	5/8	24 (18)
1/2-20	3/4	11/16	30 (22)
9/16-18	3/4	3/4	37 (27)
3/4-16	7/8	15/16	75 (55)
7/8-14	1-1/16	1-1/16	103 (76)
1-1/16-12	1-1/4	1-3/8	177 (131)
1-3/16-12	1-3/8	1-1/2	231 (170)
1-5/16-12	1-1/2	1-5/8	270 (199)
1-5/8-12	1-3/4	1-7/8	286 (211)
1-7/8-12	2-1/8	2-1/8	326 (240)

^a***Straight hex size applies to fittings only and may not be the same as the corresponding plug of the same thread size.***

1. Inspect fitting and connector sealing surfaces and the O-rings. They must be free of dirt, scratches, nicks, and burrs. O-ring must be free of dirt, cuts, cracks, swelling or flatten condition.
2. Back the stud end hex nut off as far as possible. Push backup washer towards the nut to fully expose the turn down section. Washer must fit turned down section and not be too loose
3. Lubricate O-rings using a thin film of clean hydraulic oil or as needed, petroleum jelly to hold O-ring in place.

Install O-ring into groove making sure it is seated at the bottom. Excess petroleum jelly will prevent seating of O-ring and cause it to pop out.

To protect an O-ring from threads, wrap electrical tape over the threads. Slide O-ring over the tape into the turned down section. Remove the tape.

4. Turn fitting into the boss by hand until face of nut or washer squeezes the O-ring into the seat and contacts face of boss. Loosen adjustable fittings no more than one turn for alignment.

Hold connections together while tightening nut to ensure O-ring remains in place.

5. Tighten fitting or nut to torque value shown. Use a second wrench to hold the fitting in position or to keep hose from twisting while tightening nut.

Go to [Section_00:Group_03](#)

OUT3035,0000420-19-20090504

O-Ring Face Seal Fittings With Metric Hex Nut And Stud End For Standard Pressure Service Recommendations

-: O-Ring Face Seal Fittings with Metric Hex and Stud End for Standard Pressure Torque Values

O-RING FACE SEAL AND FITTINGS WITH METRIC HEX NUT AND STUD END FOR STANDARD PRESSURE, BELOW 27 600 kPa (275.8 bar) (4,000 psi), TORQUE VALUES—Tolerance is +15 -20% unless otherwise specified

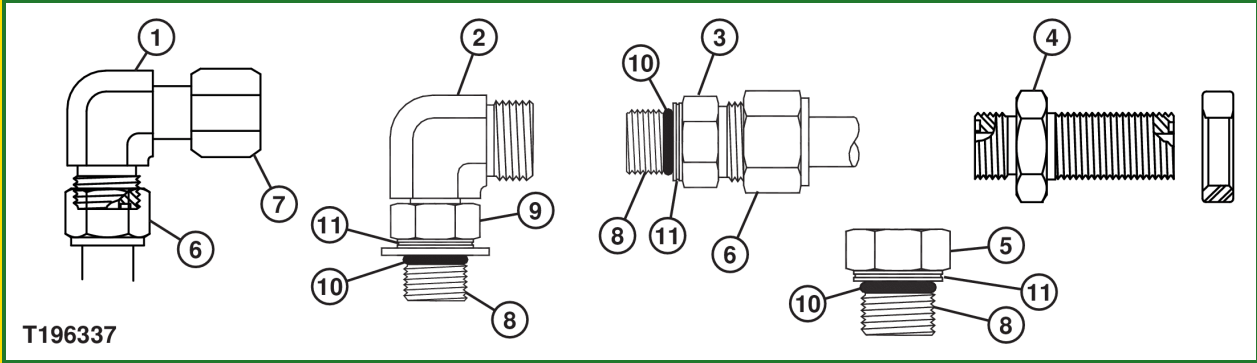

T196337-UN: O-Ring Face Seal Fittings

LEGEND:

- 1 - 90° Swivel Elbow
- 2 - 90° Adjustable Stud Elbow
- 3 - Stud Straight
- 4 - Bulkhead Union and Nut
- 5 - External Hex Stud End Plug
- 6 - Tube Nut
- 7 - Swivel Nut
- 8 - Stud End
- 9 - Hex Nut
- 10 - O-Ring
- 11 - Identification Groove

Nominal Tube OD or Hose ID			O-Ring Face Seal Hose or Tube Swivel Nut			Bulkhead Nut	
Metric Tube OD	Inch Tube OD or Hose ID		Thread Size	Hex Size	Torque	Hex Size	Torque
mm	Dash Size	mm (in.)	in.	mm	Nm (lb-ft)	mm	Nm (lb-ft)
4	-2	3.18 (0.125)	—	—	—	—	—
5	-3	4.78 (0.188)	—	—	—	—	—
6	-4	6.35 (0.250)	9/16-18	17	16 (12)	22	32 (24)
8	-5	7.92 (0.312)	—	—	—	—	—
10	-6	9.53 (0.375)	11/16-16	22	24 (18)	27	42 (31)
12	-8	12.70 (0.500)	13/16-16	24	50 (37)	30	93 (69)
16	-10	15.88 (0.625)	1-14	30	69 (51)	36	118 (87)
20	-12	19.05 (0.750)	1-3/16-12	36	102 (75)	41	175 (129)
22	-14	22.23 (0.875)	1-3/16-12	36	102 (75)	41	175 (129)
25	-16	25.40 (1.000)	1-7/16-12	41	142 (105)	46	247 (182)

O-RING FACE SEAL AND FITTINGS WITH METRIC HEX NUT AND STUD END FOR STANDARD PRESSURE, BELOW 27 600 kPa (275.8 bar) (4,000 psi), TORQUE VALUES—Tolerance is +15 -20% unless otherwise specified

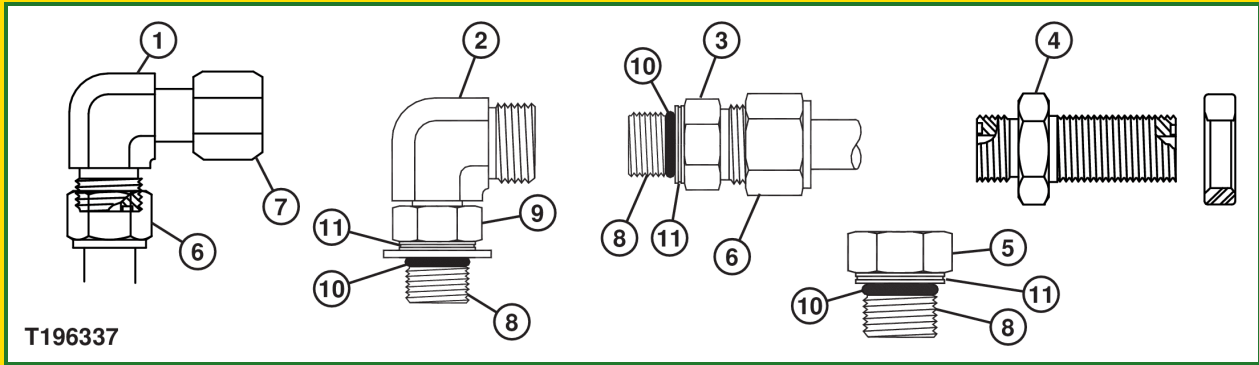

T196337-UN: O-Ring Face Seal Fittings

LEGEND:

- 1 - 90° Swivel Elbow
- 2 - 90° Adjustable Stud Elbow
- 3 - Stud Straight
- 4 - Bulkhead Union and Nut
- 5 - External Hex Stud End Plug
- 6 - Tube Nut
- 7 - Swivel Nut
- 8 - Stud End
- 9 - Hex Nut
- 10 - O-Ring
- 11 - Identification Groove

Nominal Tube OD or Hose ID			O-Ring Face Seal Hose or Tube Swivel Nut			Bulkhead Nut	
Metric Tube OD	Inch Tube OD or Hose ID		Thread Size	Hex Size	Torque	Hex Size	Torque
mm	Dash Size	mm (in.)	in.	mm	Nm (lb-ft)	mm	Nm (lb-ft)
28	—	—	—	—	—	—	—
32	-20	31.75 (1.250)	1-11/16-12	50	190 (140)	50	328 (242)
38	-24	38.10 (1.500)	2-12	60	217 (160)	60	374 (276)
50	-32	50.80 (2.000)	—	—	—	—	—

O-RING STRAIGHT, ADJUSTABLE, AND EXTERNAL HEX PLUG WITH METRIC STUD END FOR STANDARD PRESSURE, BELOW 27 600 kPa (275.8 bar) (4,000 psi), TORQUE VALUES—Tolerance is +15 -20% unless otherwise specified

Thread Size ^a	Straight Hex Size ^b	Adjustable Nut Hex Size	Steel or Gray Iron Torque	Aluminum or Brass Torque
mm.	mm	mm	Nm (lb-ft)	Nm (lb-ft)
M8 x 1	12	12	8 (6)	5 (4)
M10 x 1	14	14	15 (11)	10 (7)
M12 x 1.5	17	17	25 (18)	17 (12)
M14 x 1.5	19	19	40 (30)	27 (20)

O-RING STRAIGHT, ADJUSTABLE, AND EXTERNAL HEX PLUG WITH METRIC STUD END FOR STANDARD PRESSURE, BELOW 27 600 kPa (275.8 bar) (4,000 psi), TORQUE VALUES—Tolerance is +15 -20% unless otherwise specified

Thread Size ^a	Straight Hex Size ^b	Adjustable Nut Hex Size	Steel or Gray Iron Torque	Aluminum or Brass Torque
mm.	mm	mm	Nm (lb-ft)	Nm (lb-ft)
M16 x 1.5	22	22	45 (33)	30 (22)
M18 x 1.5	24	24	50 (37)	33 (25)
M22 x 1.5	27	27	69 (51)	46 (34)
M27 x 2	32	32	100 (74)	67 (49)
M30 x 2	36	36	130 (96)	87 (64)
M33 x 2	41	41	160 (118)	107 (79)
M38 x 2	46	46	176 (130)	117 (87)
M42 x 2	50	50	210 (155)	140 (103)
M48 x 2	55	55	260 (192)	173 (128)
M60 x 2	65	65	315 (232)	210 (155)

^a*Stud end threads are identified as metric by an identification groove in the hex nut next to the O-ring.*

^b*Straight hex size applies to fittings only and may not be the same as the corresponding plug of the same thread size.*

1. Inspect fitting and connector sealing surfaces and the O-rings. They must be free of dirt, scratches, nicks, and burrs. O-ring must be free of dirt, cuts, cracks, swelling or flatten condition.
2. Back the stud end hex nut off as far as possible. Push backup washer towards the nut to fully expose the turn down section. Washer must fit turned down section and not be too loose
3. Lubricate O-rings using a thin film of clean hydraulic oil or as needed, petroleum jelly to hold O-ring in place.

Install O-ring into groove making sure it is seated at the bottom. Excess petroleum jelly will prevent seating of O-ring and cause it to pop out.

To protect an O-ring from threads, wrap electrical tape over the threads. Slide O-ring over the tape into the turned down section. Remove the tape.

4. Turn fitting into the boss by hand until face of nut or washer squeezes the O-ring into the seat and contacts face of boss. Loosen adjustable fittings no more than one turn for alignment.

Hold connections together while tightening nut to ensure O-ring remains in place.

5. Tighten fitting or nut to torque value shown. Use a second wrench to hold the fitting in position or to keep hose from twisting while tightening nut.

Go to [Section_00:Group_03](#)

OUT3035,0000366-19-20090528

O-Ring Face Seal Fittings With Metric Hex Nut And Stud End For High Pressure Service Recommendations

-: O-Ring Face Seal Fittings with Metric Hex Nut and Stud End For Standard Pressure Torque Values

O-RING FACE SEAL FITTINGS WITH METRIC HEX NUT AND STUD END FOR HIGH PRESSURE, ABOVE 27 600 kPa (275.8 bar) (4,000 psi), TORQUE VALUES—Tolerance is +15 -20% unless otherwise specified

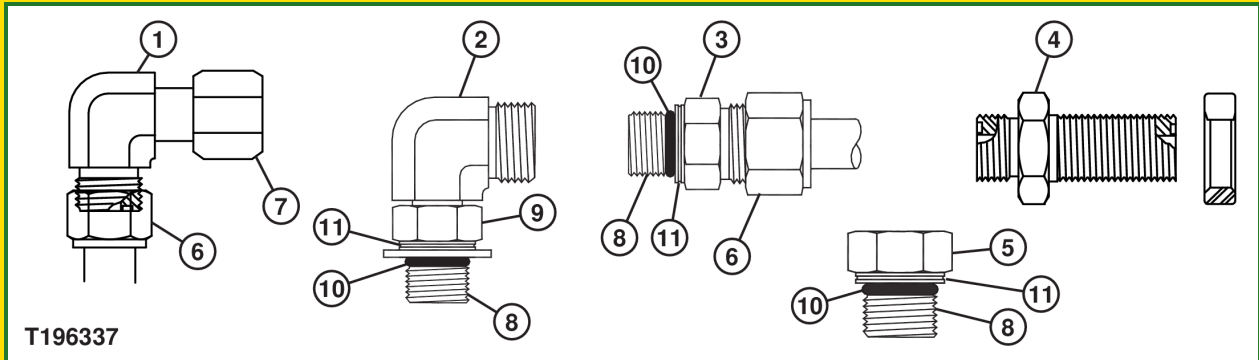

T196337

T196337-UN: O-Ring Face Seal Fittings

LEGEND:

- 1 - 90° Swivel Elbow
- 2 - 90° Adjustable Stud Elbow
- 3 - Stud Straight
- 4 - Bulkhead Union and Nut
- 5 - External Hex Stud End Plug
- 6 - Tube Nut
- 7 - Swivel Nut
- 8 - Stud End
- 9 - Hex Nut
- 10 - O-Ring
- 11 - Identification Groove

Nominal Tube OD or Hose ID			O-Ring Face Seal Hose or Tube Swivel Nut			Bulkhead Nut	
Metric Tube OD	Inch Tube OD or Hose ID		Thread Size	Hex Size	Torque	Hex Size	Torque
mm	Dash Size	mm (in.)	in.	mm	Nm (lb-ft)	mm	Nm (lb-ft)
4	-2	3.18 (0.125)	—	—	—	—	—
5	-3	4.78 (0.188)	—	—	—	—	—
6	-4	6.35 (0.250)	9/16-18	17	24 (18)	22	32 (24)
8	-5	7.92 (0.312)	—	—	—	—	—
10	-6	9.53 (0.375)	11/16-16	22	37 (27)	27	42 (31)
12	-8	12.70 (0.500)	13/16-16	24	75 (55)	30	93 (69)
16	-10	15.88 (0.625)	1-14	30	103 (76)	36	118 (87)
20	-12	19.05 (0.750)	1-3/16-12	36	152 (112)	41	175 (129)
22	-14	22.23 (0.875)	1-3/16-12	36	152 (112)	41	175 (129)
25	-16	25.40 (1.000)	1-7/16-12	41	214 (158)	46	247 (182)
28	—	—	—	—	—	—	—

O-RING FACE SEAL FITTINGS WITH METRIC HEX NUT AND STUD END FOR HIGH PRESSURE, ABOVE 27 600 kPa (275.8 bar) (4,000 psi), TORQUE VALUES—Tolerance is +15 -20% unless otherwise specified

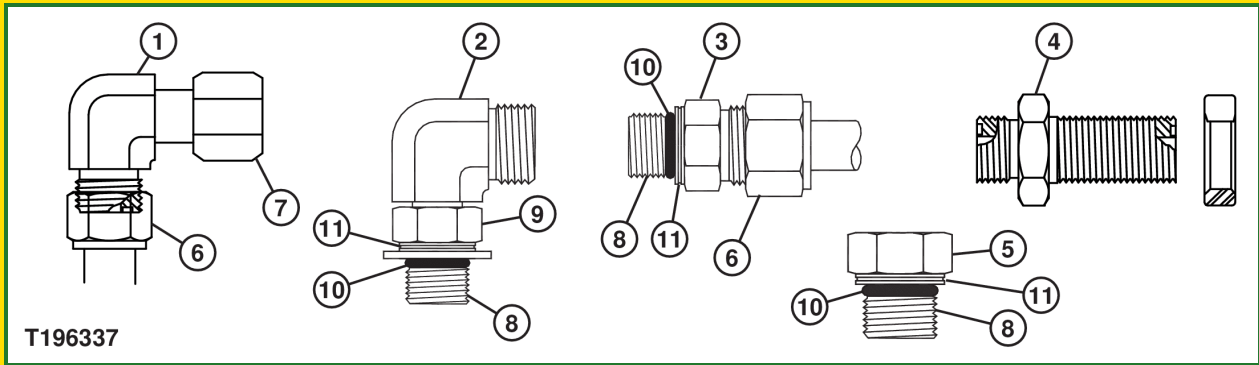

T196337-UN: O-Ring Face Seal Fittings

LEGEND:

- 1 - 90° Swivel Elbow
- 2 - 90° Adjustable Stud Elbow
- 3 - Stud Straight
- 4 - Bulkhead Union and Nut
- 5 - External Hex Stud End Plug
- 6 - Tube Nut
- 7 - Swivel Nut
- 8 - Stud End
- 9 - Hex Nut
- 10 - O-Ring
- 11 - Identification Groove

Nominal Tube OD or Hose ID			O-Ring Face Seal Hose or Tube Swivel Nut			Bulkhead Nut	
Metric Tube OD	Inch Tube OD or Hose ID		Thread Size	Hex Size	Torque	Hex Size	Torque
mm	Dash Size	mm (in.)	in.	mm	Nm (lb-ft)	mm	Nm (lb-ft)
32	-20	31.75 (1.250)	1-11/16-12	—	286 (211)	50	328 (242)
38	-24	38.10 (1.500)	2-12	—	326 (240)	60	374 (276)

O-RING STRAIGHT, ADJUSTABLE, AND EXTERNAL HEX PLUG WITH METRIC STUD END FOR HIGH PRESSURE, ABOVE 27 600 KPA (275.8 BAR) (4,000 PSI), TORQUE VALUES—Tolerance is +15 -20% unless otherwise specified

Thread Size ^a	Straight Hex Size ^b	Adjustable Nut Hex Size	Steel or Gray Iron Torque
mm.	mm	mm	Nm (lb-ft)
M8 x 1	12	12	8 (6)
M10 x 1	14	14	15 (11)
M12 x 1.5	17	17	35 (26)
M14 x 1.5	19	19	45 (33)
M16 x 1.5	22	22	55 (41)
M18 x 1.5	24	24	70 (52)
M22 x 1.5	27	27	100 (74)
M27 x 2	32	32	170 (125)

O-RING STRAIGHT, ADJUSTABLE, AND EXTERNAL HEX PLUG WITH METRIC STUD END FOR HIGH PRESSURE, ABOVE 27 600 KPA (275.8 BAR) (4,000 PSI), TORQUE VALUES—Tolerance is +15 -20% unless otherwise specified

Thread Size ^a	Straight Hex Size ^b	Adjustable Nut Hex Size	Steel or Gray Iron Torque
mm.	mm	mm	Nm (lb-ft)
M30 x 2	36	36	215 (159)
M33 x 2	41	41	260 (192)
M38 x 2	46	46	320 (236)
M42 x 2	50	50	360 (266)
M48 x 2	55	55	420 (310)

^a*Stud end threads are identified as metric by an identification groove in the hex nut next to the O-ring.*

^b*Straight hex size applies to fittings only and may not be the same as the corresponding plug of the same thread size.*

1. Inspect fitting and connector sealing surfaces and the O-rings. They must be free of dirt, scratches, nicks, and burrs. O-ring must be free of dirt, cuts, cracks, swelling or flatten condition.
2. Back the stud end hex nut off as far as possible. Push backup washer towards the nut to fully expose the turn down section. Washer must fit turned down section and not be too loose
3. Lubricate O-rings using a thin film of clean hydraulic oil or as needed, petroleum jelly to hold O-ring in place.

Install O-ring into groove making sure it is seated at the bottom. Excess petroleum jelly will prevent seating of O-ring and cause it to pop out.

To protect an O-ring from threads, wrap electrical tape over the threads. Slide O-ring over the tape into the turned down section. Remove the tape.

4. Turn fitting into the boss by hand until face of nut or washer squeezes the O-ring into the seat and contacts face of boss. Loosen adjustable fittings no more than one turn for alignment.

Hold connections together while tightening nut to ensure O-ring remains in place.

5. Tighten fitting or nut to torque value shown. Use a second wrench to hold the fitting in position or to keep hose from twisting while tightening nut.

Go to [Section_00:Group_03](#)

OUT3035,0000421-19-20090528

Service Recommendations for Metric Series Four Bolt Flange Fitting

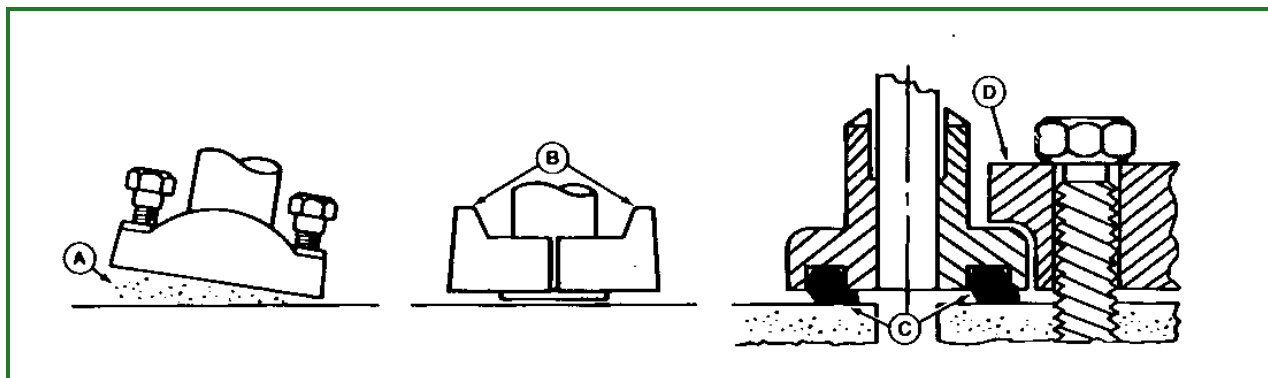

T6890BB-UN: Metric Series Four Bolt Flange Fitting

LEGEND:

- A - Sealing Surface
- B - Split Flange
- C - Pinched O-Ring
- D - Single Piece Flange

1. Clean sealing surfaces (A). Inspect. Scratches cause leaks. Roughness causes seal wear. Out-of-flat causes seal extrusion. If defects cannot be polished out, replace component.
2. Install the correct O-ring (and backup washer if required) into groove using petroleum jelly to hold it in place.
3. Split flange: Loosely assemble split flange (B) halves. Make sure split is centrally located and perpendicular to the port. Hand tighten cap screws to hold parts in place. Do not pinch O-ring (C).
4. Single piece flange (D): Place hydraulic line in center of flange and install four cap screws. Flange must be centrally located on port. Hand tighten cap screws to hold flange in place. Do not pinch O-ring.
5. After components are properly positioned and cap screws are hand tightened, tighten one cap screw, then tighten the diagonally opposite cap screw. Tighten two remaining cap screws. Tighten all cap screws as specified in the chart below.

DO NOT use air wrenches. DO NOT tighten one cap screw fully before tightening the others. DO NOT over tighten.

-: Torque Chart

TORQUE CHART [Tolerance \pm 10%. The torques given are enough for the given size connection with the recommended working pressure. Increasing cap screw torque beyond these amounts will result in flange and cap screw bending and connection failures.]		
Thread [Metric standard thread.]	N·m	lb·ft
M6	12	9
M8	30	22
M10	57	42
M12	95	70
M14	157	116
M16	217	160

TORQUE CHART [Tolerance \pm 10%. The torques given are enough for the given size connection with the recommended working pressure. Increasing cap screw torque beyond these amounts will result in flange and cap screw bending and connection failures.]

Thread [Metric standard thread.]	N·m	lb·ft
M18	334	246
M20	421	318

Go to [Section_00:Group_03](#)

04T,90,K175-19-19990929

Service Recommendations For Inch Series Four Bolt Flange Fittings

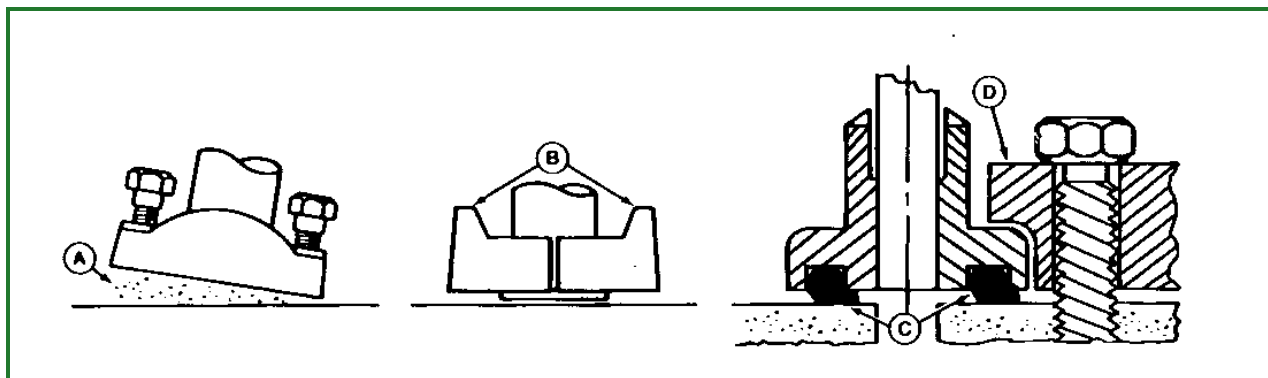

T6890BB-UN: Flange Fittings

LEGEND:

- A - Sealing Surface
- B - Split Flange
- C - Pinched O-Ring
- D - Single Piece Flange

1. Clean sealing surfaces (A). Inspect. Scratches cause leaks. Roughness causes seal wear. Out-of-flat causes seal extrusion. If defects cannot be polished out, replace component.
2. Install O-ring (and backup washer if required) into groove using petroleum jelly to hold it in place.
3. Split flange: Loosely assemble split flange (B) halves. Make sure split is centrally located and perpendicular to port. Hand tighten cap screws to hold parts in place. Do not pinch O-ring (C).
4. Single piece flange (D): Place hydraulic line in center of flange and install cap screws. Flange must be centrally located on port. Hand tighten cap screws to hold flange in place. Do not pinch O-ring.
5. Tighten one cap screw, then tighten the diagonally opposite cap screw. Tighten two remaining cap screws. Tighten all cap screws as specified in the chart below.

DO NOT use air wrenches. DO NOT tighten one cap screw fully before tightening the others. DO NOT over tighten.

-: Four Bolt Flange Fittings Torque

TORQUE CHART					
Nominal Flange Size	Cap Screw Size	N·m		lb·ft	
		Min	Max	Min	Max
1/2	5/16-18 UNC	20	31	15	23
3/4	3/8-16 UNC	28	54	21	40
1	3/8-16 UNC	37	54	27	40
1-1/4	7/16-14 UNC	47	85	35	63
1-1/2	1/2-13 UNC	62	131	46	97
2	1/2-13 UNC	73	131	54	97
2-1/2	1/2-13 UNC	107	131	79	97

TORQUE CHART					
		N·m		lb·ft	
Nominal Flange Size	Cap Screw Size	Min	Max	Min	Max
3	5/8-11 UNC	158	264	117	195
3-1/2	5/8-11 UNC	158	264	117	195
4	5/8-11 UNC	158	264	117	195
5	5/8-11 UNC	158	264	117	195

Go to [Section_00:Group_03](#)

04T,90,K174-19-19940801

Inch Series Four Bolt Flange Fitting For High Pressure Service Recommendations

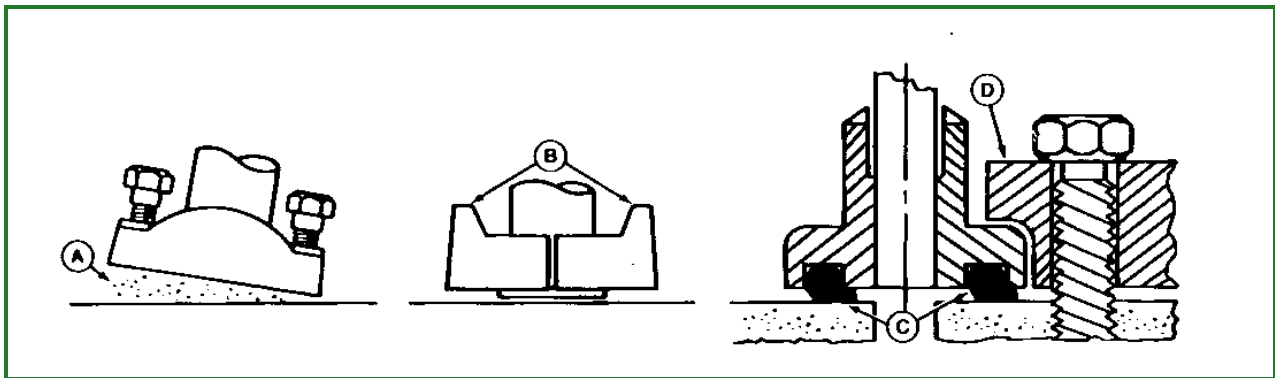

T6890BB-UN: Four Bolt Flange Fittings

LEGEND:

- A - Sealing Surface
- B - Split Flange
- C - Pinched O-Ring
- D - Single Piece Flange

-: Inch Series Four Bolt Flange Fitting High Pressure Torque Values

INCH SERIES FOUR BOLT FLANGE FITTING FOR 41 400 kPa (414 bar) (6000 psi) PRESSURE SERIES TORQUE VALUES—Tolerance is $\pm 10\%$ unless otherwise specified		
Nominal Flange Size	Cap Screw Size ^a	Min—Max Torque
in.	in.	Nm (lb-ft) ^b
1/2	5/16-18 UNC	20—31 (15—23)
3/4	3/8-16 UNC	34—54 (25—40)
1	7/16-14 UNC	57—85 (42—63)
1-1/4	1/2-13 UNC	85—131 (63—97)
1-1/2	5/8-11 UNC	159—264 (117—195)
2	3/4-10 UNC	271—468 (200—345)

^aJDM A17D, SAE Grade 5 or better cap screws with plated hardware.
Lock washers are permissible but not recommended.

^bMinimum torques given are enough for the given size connection with the recommended working pressure. Torques can be increased to the maximum shown for each cap screw size if desired. Increasing cap screw torque beyond the maximum will result in flange and cap screw bending and connection failures.

1. Clean sealing surfaces (A). Inspect. Scratches, nicks, and burrs cause leaks. Roughness causes O-ring wear. Out-of-flat causes O-ring extrusion. If imperfection cannot be polished out, replace component.

2. Install the O-ring (and backup ring, if used) into groove. Use petroleum jelly to hold it in place.

3. IMPORTANT:

DO NOT use air wrenches. DO NOT tighten one cap screw fully before tightening the others. DO NOT over tighten.

Split flange: Loosely assemble split flange (B) halves. Make sure split is centrally located and perpendicular to port. Hand tighten cap screws to hold flange halves and line in place. Do not pinch O-

ring (C).

Single piece flange (D): Make sure flange is centrally located on port and line is centered in flange. Install the cap screws. Hand tighten cap screws to hold flange and line in place. Do not pinch O-ring.

4. Tighten one cap screw and then the diagonally opposite cap screw. Tighten the two remaining cap screws. Tighten cap screws within the specified torque values.

Go to [Section_00:Group_03](#)

OUT3035,0000422-19-20090305

Service Recommendations For Non-Restricted Banjo (Adjustable) Fittings

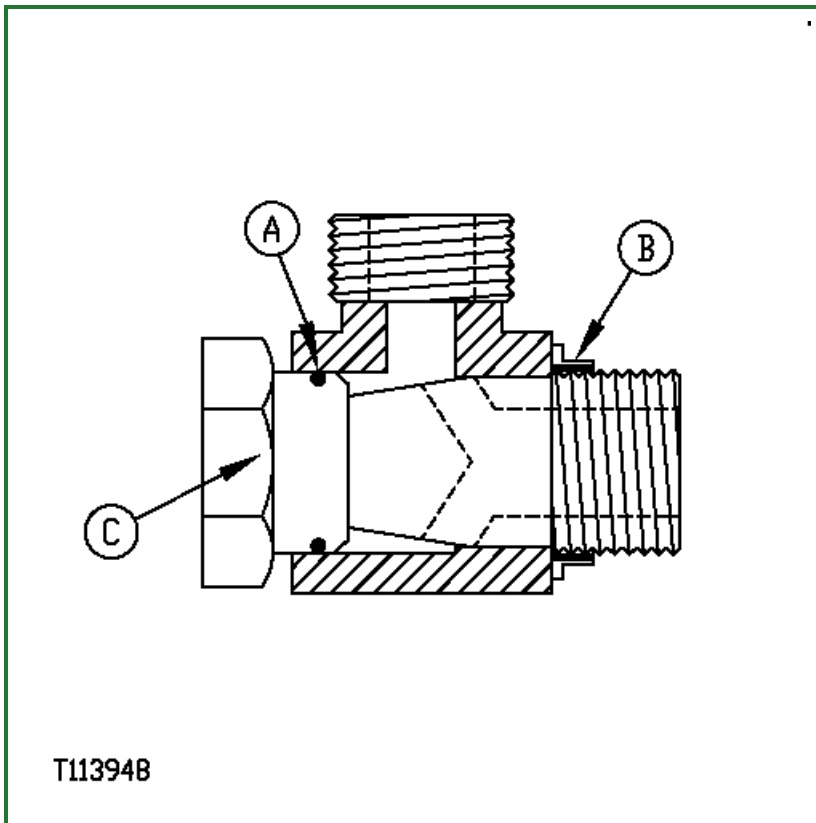

T113948-UN: Non-Restricted Banjo Fitting

1. Inspect all fitting sealing surfaces. They must be free of dirt and defects.
2. Inspect O-ring (A). It must be free of damage or defects.
3. Inspect sealing ring (B) for damage or defects.
4. Hold body in desired position while tightening stud by hand.
5. Tighten stud (C) to torque value shown on the chart. Do not allow body to twist when tightening stud.

NOTE:

The L in the Tube Fitting OD Size column indicates "light" designed fitting and the S indicates "heavy" designed fitting.

-: Torque Value—Metric

Tube Fitting O.D. Size	Torque Value		
	Metric Thread	N·m	lb·ft
6 L	M10 x 1	30	22
8 L	M12 x 1.5	40	30
10 L	M14 x 1.5	60	44
12 L	M16 x 1.5	100	74
15 L	M18 x 1.5	130	96

	Torque Value		
Tube Fitting O.D. Size	Metric Thread	N·m	lb·ft
18 L	M22 x 1.5	160	118
22 L	M26 x 1.5	250	184
28 L	M33 x 2	400	295
35 L	M42 x 2	600	443
42 L	M48 x 2	800	590
6 S	M12 x 1.5	40	30
8 S	M14 x 1.5	60	44
10 S	M16 x 1.5	100	74
12 S	M18 x 1.5	130	96
14 S	M20 x 1.5	160	118
16 S	M22 x 1.5	160	118
20 S	M27 x 2	250	184
25 S	M33 x 2	400	295
30 S	M42 x 2	600	443
38 S	M48 x 2	800	590

-: Torque Value—Inch

	Torque Value		
Tube Fitting O.D. Size	Inch Size	N·m	lb·ft
6 L	1/8	25	18
8 L	1/4	50	37
10 L	1/4	50	37
12 L	3/8	90	66
15 L	1/2	130	96
18 L	1/2	150	111
22 L	3/4	250	184
28 L	1	400	295
35 L	1-1/4	600	443
42 L	1-1/2	800	590
6 S	1/4	50	37
8 S	1/4	50	37
10 S	3/8	90	66
12 S	3/8	100	74

	Torque Value		
Tube Fitting O.D. Size	Inch Size	N·m	lb·ft
14 S	1/2	130	96
16 S	1/2	150	111
20 S	3/4	250	184
25 S	1	400	295
30 S	1-1/4	600	443
38 S	1-1/2	800	590

Go to [Section_00:Group_03](#)

CED,OUO1002,562-19-19980309

Service Recommendations For O-Ring Boss Fittings With Shoulder

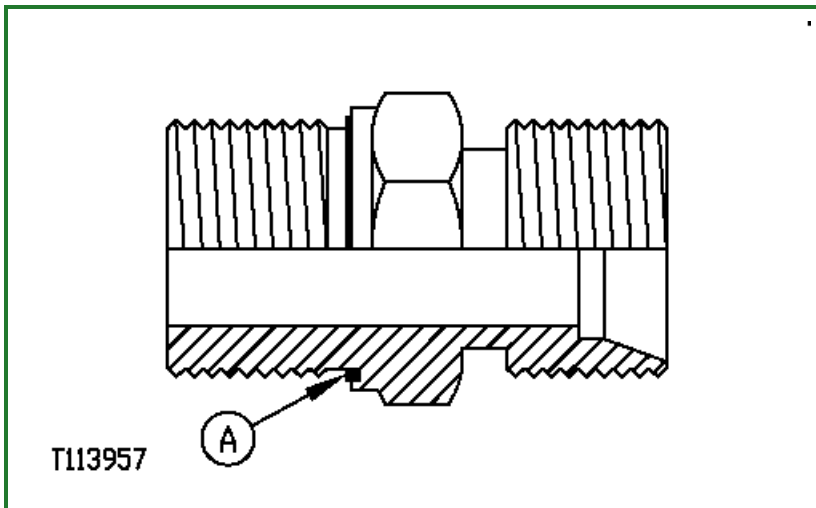

T113957-UN: O-Ring Boss Fitting With Shoulder

1. Inspect component seal boss seat for dirt or defects.
2. Inspect EOlastic seal (A) for damage. Replace seal or fitting as necessary.

To replace seal, put electrical tape over threads to protect seal. Slide seal over tape and into seal groove of fitting. Remove tape.

3. Tighten fitting to torque value shown on chart.

IMPORTANT:

Do not allow hoses to twist when tightening fittings.

NOTE:

The L in the Tube Fitting OD Size column indicates “light” designed fitting and the S indicates “heavy” designed fitting.

-: Torque Value—Metric

Tube Fitting O.D. Size	Torque Value		
	Metric Thread	N·m	lb·ft
6 L	M10 x 1	20	15
8 L	M12 x 1.5	30	22
10 L	M14 x 1.5	45	33
12 L	M16 x 1.5	60	44
15 L	M18 x 1.5	80	59
18 L	M22 x 1.5	130	96
22 L	M26 x 1.5	190	140
28 L	M33 x 2	300	221

Tube Fitting O.D. Size	Torque Value		
	Metric Thread	N·m	lb·ft
35 L	M42 x 2	600	443
42 L	M48 x 2	800	590
6 S	M12 x 1.5	40	30
8 S	M14 x 1.5	60	44
10 S	M16 x 1.5	80	59
12 S	M18 x 1.5	110	81
14 S	M20 x 1.5	140	103
16 S	M22 x 1.5	170	125
20 S	M27 x 2	250	184
25 S	M33 x 2	450	332
30 S	M42 x 2	600	443
38 S	M48 x 2	800	590

-: Torque Value—Inch

Tube Fitting O.D. Size	Torque Value		
	Inch Size	N·m	lb·ft
6 L	1/8	20	15
8 L	1/4	40	30
10 L	1/4	40	30
12 L	3/8	80	59
15 L	1/2	140	103
18 L	1/2	100	74
22 L	3/4	180	133
28 L	1	300	221
35 L	1-1/4	600	443
42 L	1-1/2	800	590
6 S	1/4	50	37
8 S	1/4	50	37
10 S	3/8	90	66
12 S	3/8	90	66
14 S	1/2	160	118
16 S	1/2	140	103
20 S	3/4	250	184

	Torque Value		
Tube Fitting O.D. Size	Inch Size	N·m	lb·ft
25 S	1	400	295
30 S	1-1/4	650	479
38 S	1-1/2	800	590

-: Torque Value—Hex Socket Head Plugs Only

Hex Socket Head Plugs Only		
Torque Value		
Thread Size	N·m	lb·ft
M10 x 1	13	10
M12 x 1.5	30	22
M14 x 1.5	40	30
M16 x 1.5	60	44
M18 x 1.5	70	52
M20 x 1.5	90	66
M22 x 1.5	100	74
M26 x 1.5	120	89
M27 x 2	150	111
M33 x 2	250	184
M42 x 2	400	295
M48 x 2	500	369
1/8	15	11
1/4	33	24
3/8	70	52
1/2	90	66
3/4	150	111
1	220	162
1-1/4	600	443
1-1/2	800	590

Go to [Section_00:Group_03](#)

CED,OUO1002,563-19-19980309

Metric 24° O-Ring Seal DIN 20078 Service Recommendations

-: Metric 24° O-Ring Seal Din 20078 Torque Values

METRIC 24° O-RING SEAL DIN 20078 TORQUE VALUES

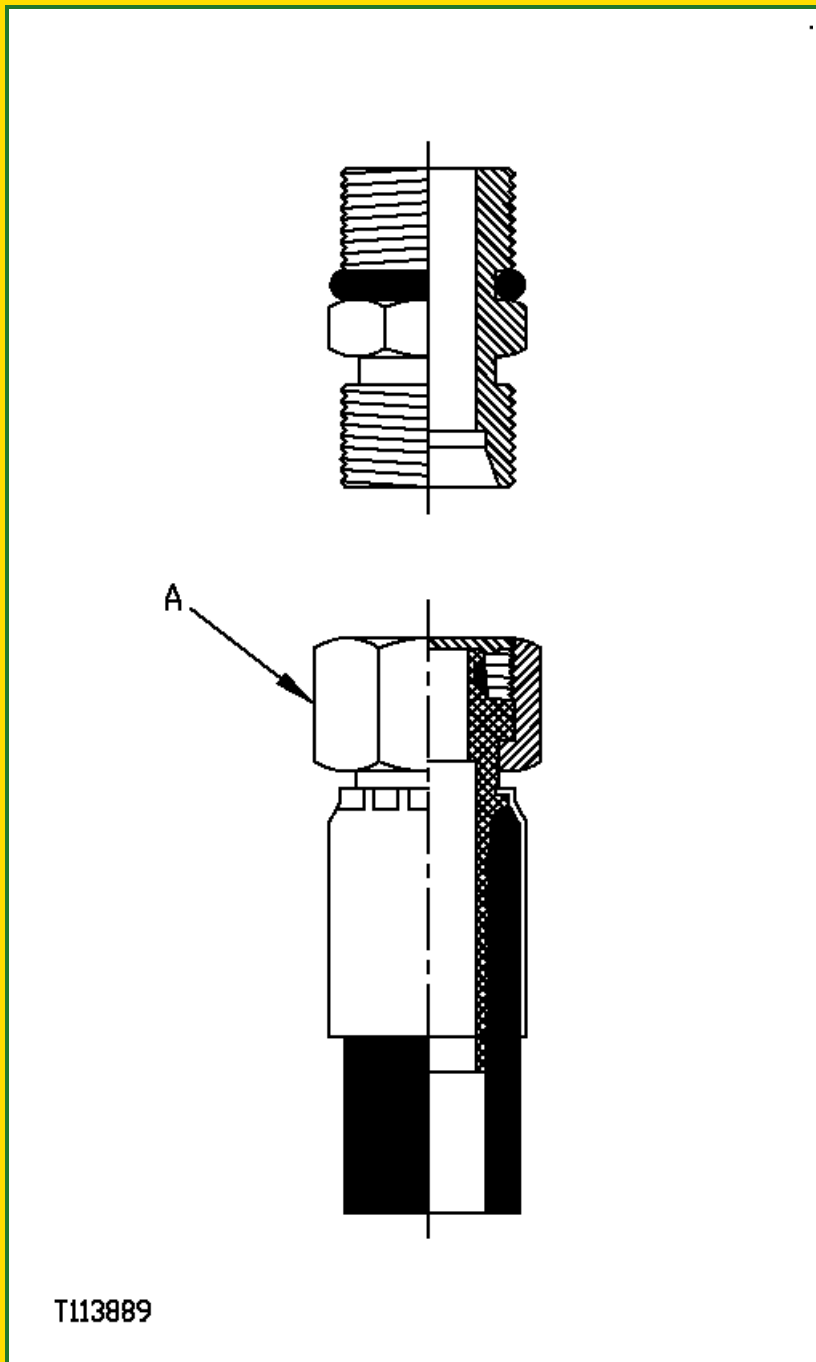

T113889-UN: Connection

Fitting Tube OD Size	Heavy Fitting Size	Light Fitting Size	Torque
mm	mm	mm	Turns
6	—	M12 x 1.5	
8	M16 x 1.5	M14 x 1.5	
10	M18 x 1.5	M16 x 1.5	
12	M20 x 1.5	M18 x 1.5	

METRIC 24° O-RING SEAL DIN 20078 TORQUE VALUES

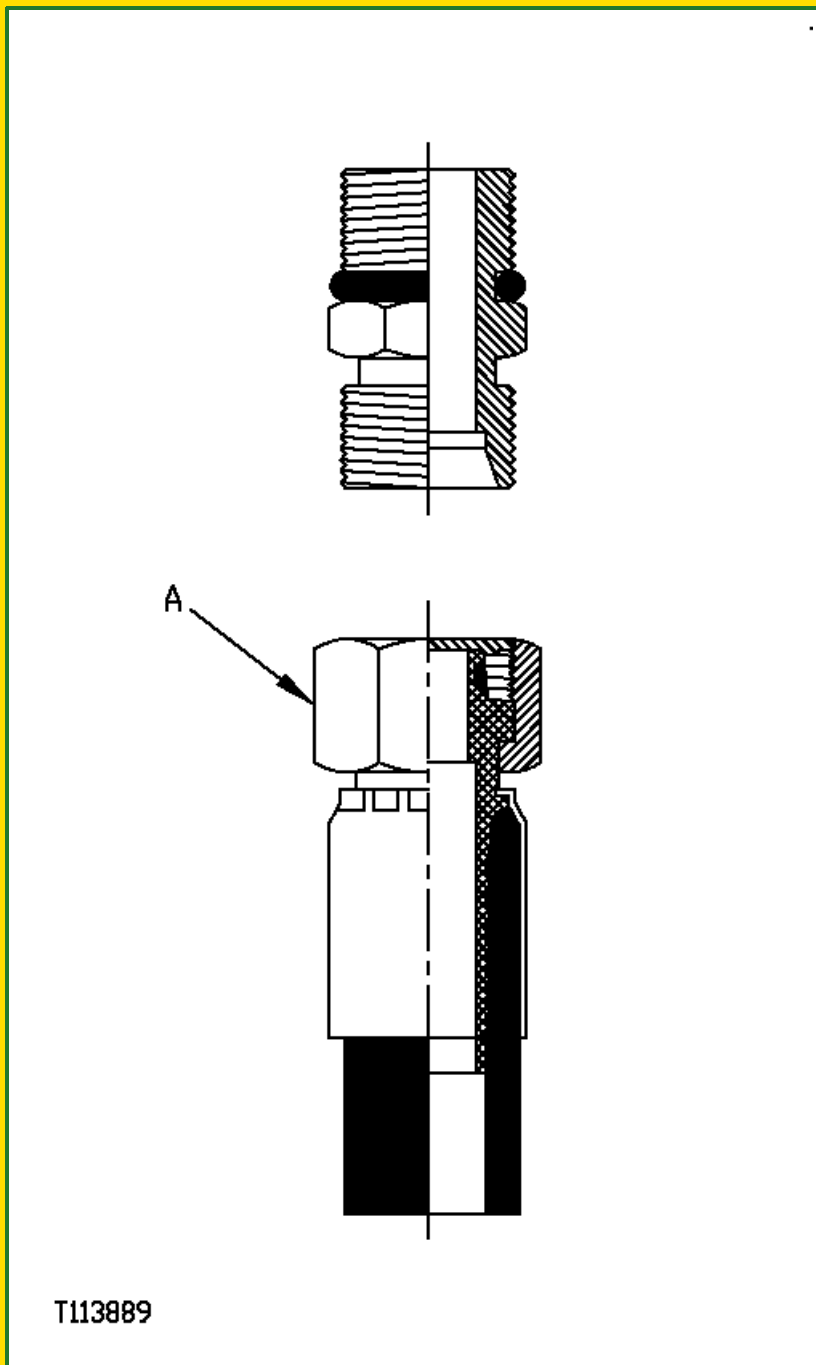

T113889-UN: Connection

Fitting Tube OD Size	Heavy Fitting Size	Light Fitting Size	Torque
mm	mm	mm	Turns
14	M22 x 1.5	—	Hand tighten so O-ring contacts seat plus an additional 1/4—1/3 turn using a wrench
15	—	M22 x 1.5	
16	M24 x 1.5	—	
18	—	M26 x 1.5	
20	M30 x 2	—	
22	—	M30 x 2	
25	M36 x 2	—	

METRIC 24° O-RING SEAL DIN 20078 TORQUE VALUES

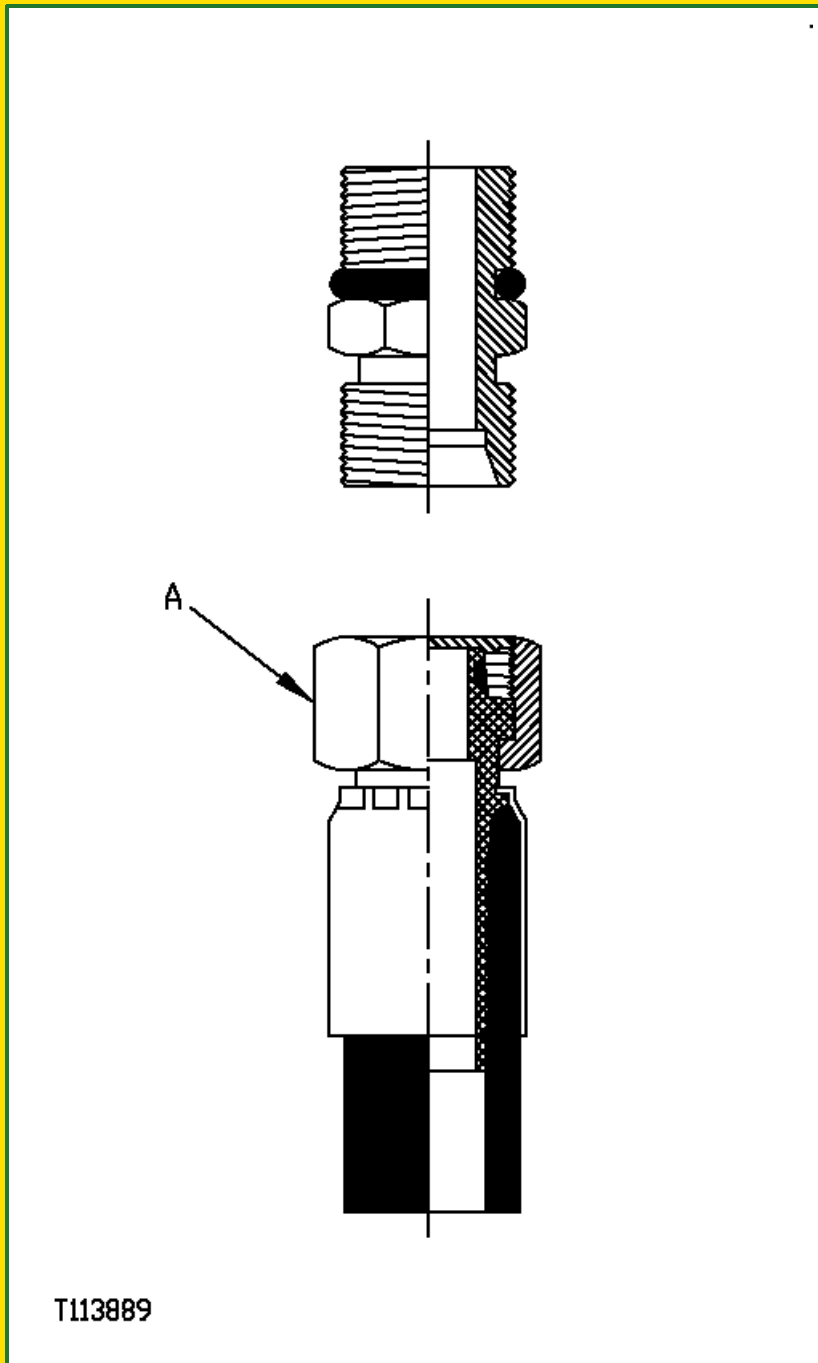

T113889-UN: Connection

Fitting Tube OD Size	Heavy Fitting Size	Light Fitting Size	Torque
mm	mm	mm	Turns
28	—	M36 x 2	
30	M42 x 2	—	
35	—	M45 x 2	
38	M52 x 2	—	

1.

NOTE:

These fittings are also referred to as EO and EO-2 Bite Type or Ermeto style fittings.

IMPORTANT:

In this style of fittings, there are “heavy” and “light” designs. Usually “heavy” is used for pressure lines and “light” for return lines.

Some “heavy” and “light” sizes can be threaded together but do not seal properly. Be sure not to mix “heavy” and “light” fittings.

Inspect the fitting sealing surfaces. They must be free of dirt scratches, nicks, and burrs.

2. Inspect the O-ring. It must be free dirt, cuts, cracks, swelling or flatten condition.
3. Lubricate O-rings using a thin film of clean hydraulic oil.
4. Align an adjustable fitting with the tube.

Hold connections together while tightening nut to ensure proper seal.

5. Tighten nut (A) hand tight so O-ring contacts seat and then an additional 1/4—1/3 turn using a wrench.

Go to [Section_00:Group_03](#)

CED,OUO1002,517-19-20040114

Section 01: Tracks

Group 0130: Track System

Rock Guards and Chain Guides Remove and Install

Carrier Roller Remove and Install

Carrier Roller Disassemble and Assemble

Metal Face Seals Inspection

Track Roller Remove and Install

Track Roller Disassemble and Assemble

Track Roller Leakage Test

Track Shoe Remove and Install

Sealed Track Chain Removal

Sealed Track Chain Disassemble and Assemble

Sealed Track Chain Installation

Lubricated Track Chain (Saw Tooth Master Split Link) Remove and Install

Lubricated Track Chain Disassembly (Turn Bushings and Lubricate Chain)

Lubricated Track Chain Assembly (Turn Bushings and Lubricate Chain)

Lubricated Track Chain Disassemble and Assemble (Turn Pins and Not Lubricate)

Front Idler Remove and Install

Front Idler Disassemble, Inspect, and Assemble

Front Idler Adjustment

Front Idler Oil Level Check

Track Tension Adjuster Remove and Disassemble

Track Tension Adjuster Assemble and Install

Track Idler Recoil Spring Remove and Install

Track Idler Recoil Spring Disassemble and Assemble

Sprocket Remove and Install

Track Frame Remove and Install

Track Frame Disassemble and Assemble

Frame Wear Strips Remove and Install

Rock Guards and Chain Guides Remove and Install

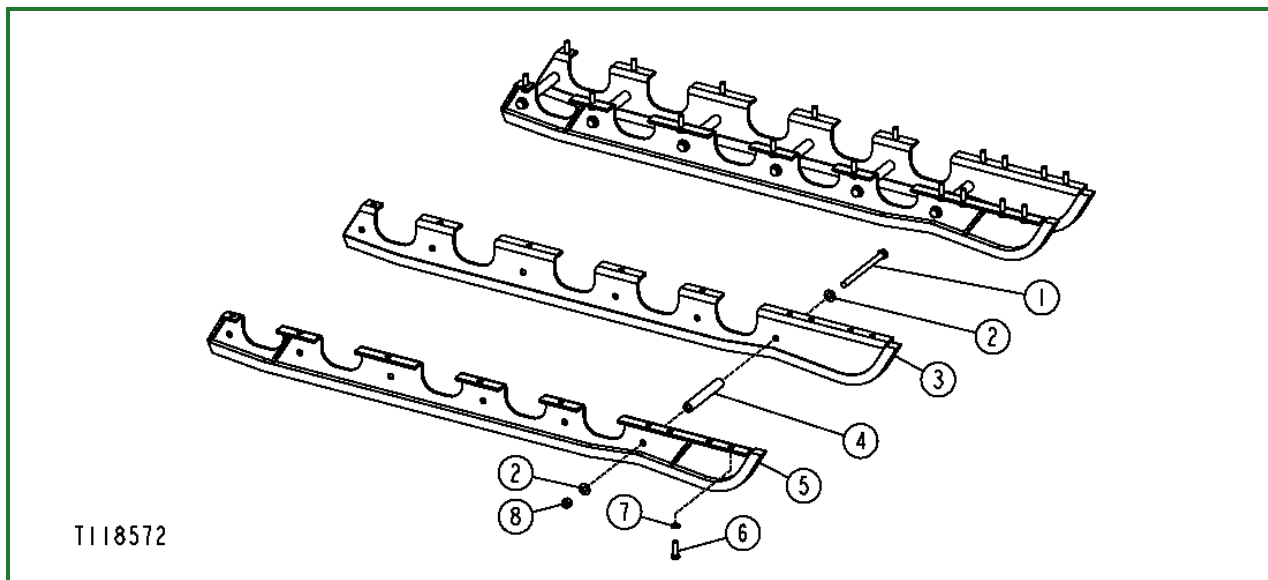

T118572-UN: 450J Standard Rock Guards Shown

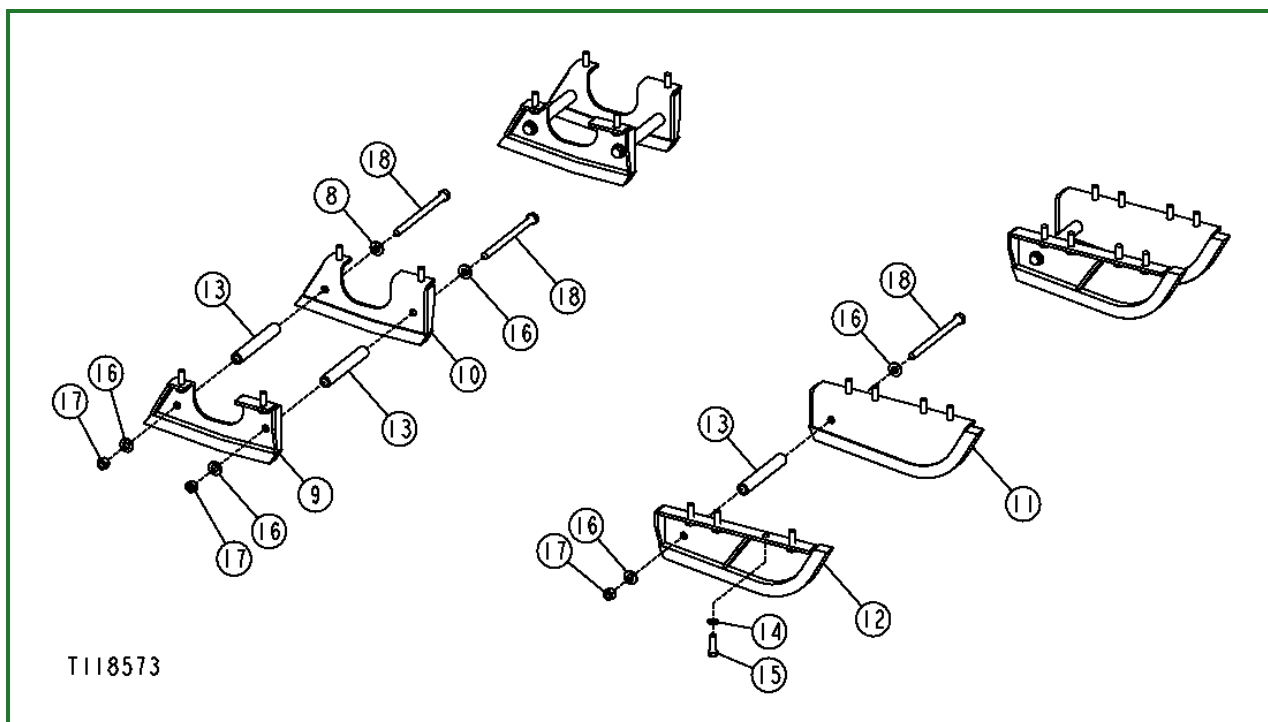

T118573-UN: 450J Standard Chain Guides Shown

LEGEND:

- 1 - Cap Screw—450J (6 used); 550J, 650J, and 605C (7 used)
- 2 - Washer—450J (12 used); 550J, 650J, and 605C (14 used)
- 3 - Rock Guard Outside
- 4 - Spacer—450J (6 used); 550J, 650J, and 605C (7 used)
- 5 - Rock Guard Inside
- 6 - Cap Screw—450J (18 used); 550J, 650J, and 605C (20 used)
- 7 - Washer—450J (18 used); 550J, 650J, and 605C (20 used)
- 8 - Nut (6 used)
- 9 - Guide
- 10 - Guide
- 11 - Guide
- 12 - Guide

- 13 - Spacer (3 used)
- 14 - Washer (12 used)
- 15 - Cap Screw (12 used)
- 16 - Washer (6 used)
- 17 - Nut (3 used)
- 18 - Cap Screw (3 used)

1.

⚠ CAUTION:

Rock Guard is heavy and can cause injury if not moved properly. Use adequate lifting device to move rock guard.

Item	Measurement	Specification
Rock Guard		
Rock Guard Approximate Weight		100 kg 220 lb

Use a chain and hoist when removing rock guards. Inspect parts, replace if necessary.

2. Tighten rock guard cap screws.

Item	Measurement	Specification
Rock Guard		
Rock Guard-to-Track Frame Cap Screws	Torque	203 N·m 150 lb-ft
Rock Guard-to-Spacer-to-Rock Guard Cap Screws	Torque	278 N·m 205 lb-ft

3. Tighten chain guide cap screws.

Item	Measurement	Specification
Chain Guides		
Chain Guides-to-Track Frame Cap Screws	Torque	203 N·m 150 lb-ft
Chain Guide-to-Spacer-to-Rock Guard Cap Screws	Torque	278 N·m 205 lb-ft

Go to [Section_01:Group_0130](#)

CED,OUTX547,66-19-20060119

Rock Guards and Chain Guides Remove and Install

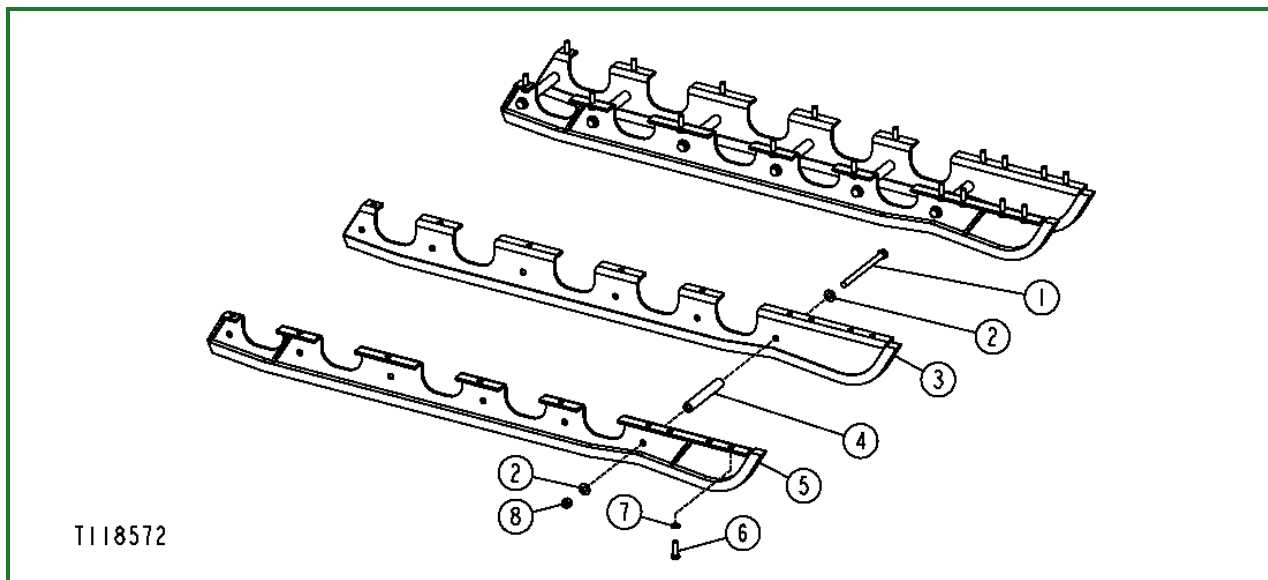

T118572-UN: 450J Standard Rock Guards Shown

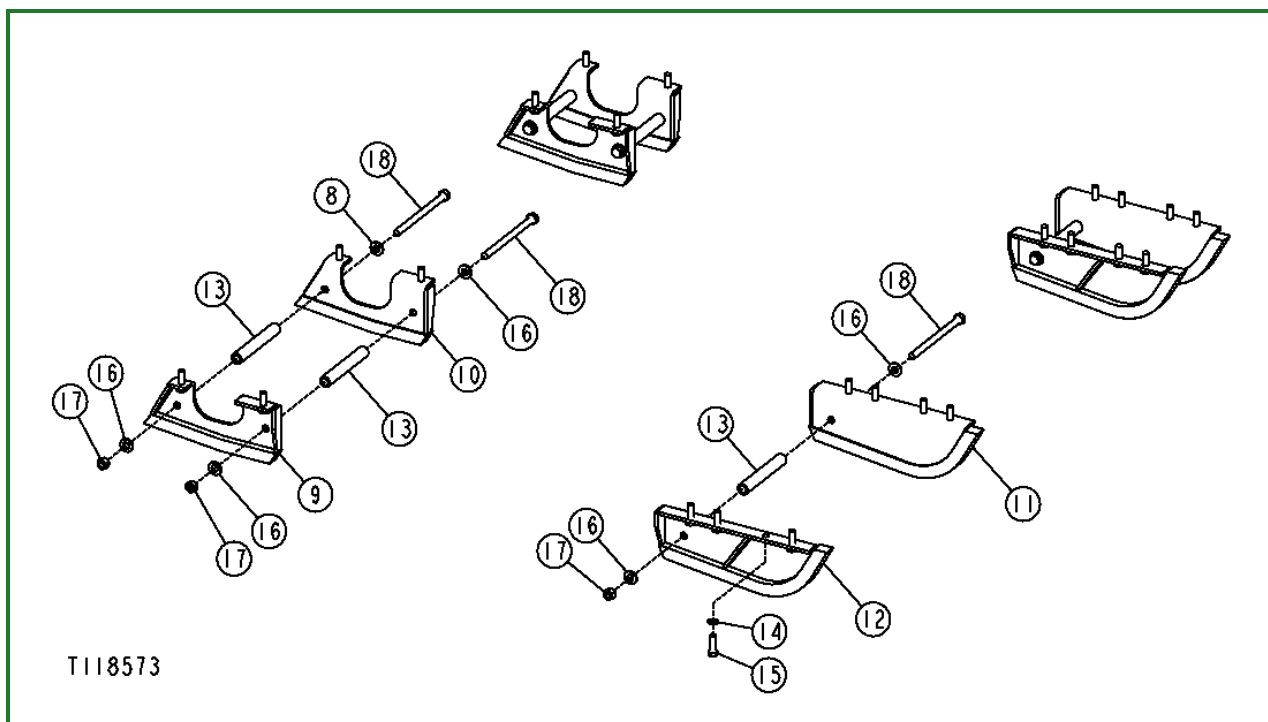

T118573-UN: 450J Standard Chain Guides Shown

LEGEND:

- 1 - Cap Screw—450J (6 used); 550J, 650J, and 605C (7 used)
- 2 - Washer—450J (12 used); 550J, 650J, and 605C (14 used)
- 3 - Rock Guard Outside
- 4 - Spacer—450J (6 used); 550J, 650J, and 605C (7 used)
- 5 - Rock Guard Inside
- 6 - Cap Screw—450J (18 used); 550J, 650J, and 605C (20 used)
- 7 - Washer—450J (18 used); 550J, 650J, and 605C (20 used)
- 8 - Nut (6 used)
- 9 - Guide
- 10 - Guide
- 11 - Guide
- 12 - Guide

- 13 - Spacer (3 used)
- 14 - Washer (12 used)
- 15 - Cap Screw (12 used)
- 16 - Washer (6 used)
- 17 - Nut (3 used)
- 18 - Cap Screw (3 used)

1.

⚠ CAUTION:

Rock Guard is heavy and can cause injury if not moved properly. Use adequate lifting device to move rock guard.

Item	Measurement	Specification
Rock Guard		
Rock Guard Approximate Weight		100 kg 220 lb

Use a chain and hoist when removing rock guards. Inspect parts, replace if necessary.

2. Tighten rock guard cap screws.

Item	Measurement	Specification
Rock Guard		
Rock Guard-to-Track Frame Cap Screws	Torque	203 N·m 150 lb-ft
Rock Guard-to-Spacer-to-Rock Guard Cap Screws	Torque	278 N·m 205 lb-ft

3. Tighten chain guide cap screws.

Item	Measurement	Specification
Chain Guides		
Chain Guides-to-Track Frame Cap Screws	Torque	203 N·m 150 lb-ft
Chain Guide-to-Spacer-to-Rock Guard Cap Screws	Torque	278 N·m 205 lb-ft

Go to [Section_01:Group_0130](#)

CED,OUTX547,66-19-20060119

Carrier Roller Remove and Install**⚠ CAUTION:**

Grease for track adjuster cylinder is under high pressure. Never remove grease fitting to release the grease. If grease does not escape immediately from vent hole when fitting has been loosened, slowly drive unit in forward and reverse until grease escapes. DO NOT disassemble parts unless you know the correct procedure and have correct tools. (See your authorized dealer.)

If an accident occurs, see a doctor immediately. Any fluid injected into the skin must be surgically removed within a few hours or gangrene may result. Doctors unfamiliar with this type of injury may call the Deere & Company Medical Department in Moline, Illinois, or other knowledgeable medical source.

1.

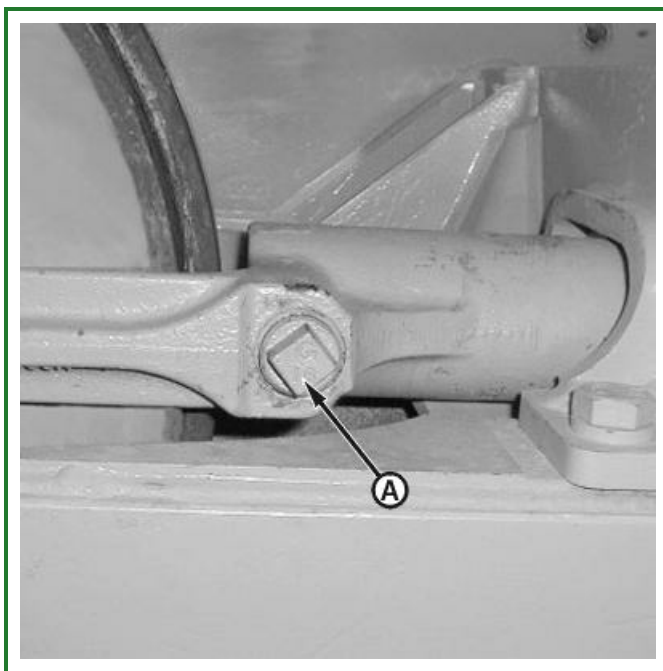
**T118011B-UN: Remove Plug****LEGEND:**

A - Access Plug

Remove access plug (A).

2.

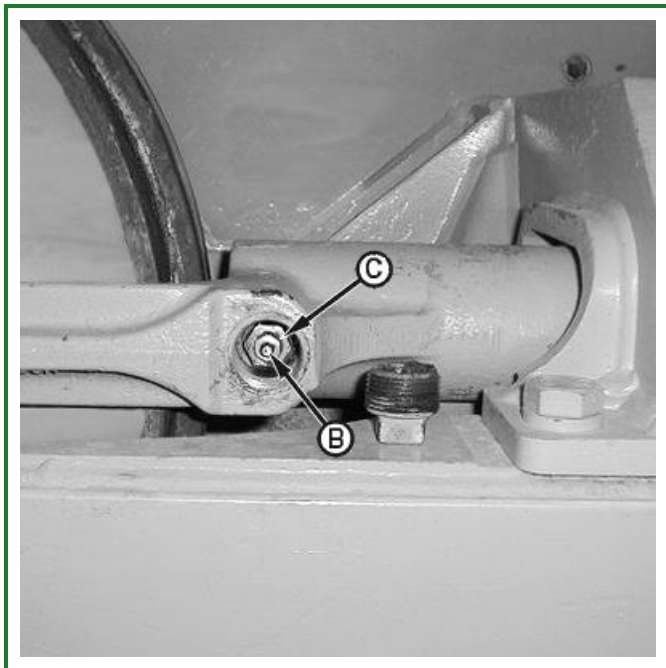

T118012B-UN: Grease Fitting



T118013B-UN: Vent Hole

LEGEND:

B - Grease Fitting

C - Fitting

D - Vent Hole

To increase track sag:

1. Loosen fitting (C) (not the grease fitting), one to two turns counterclockwise to release grease through vent hole (D).
2. Tighten fitting.
3. Move machine forward and reverse to allow track adjuster cylinder to fully adjust.

3. Install plug.

4.

⚠ CAUTION:

Securely support track before attempting service procedure to prevent accidental lowering of track.

Use a jack to raise track link enough to permit carrier roller removal. Secure track.

5.

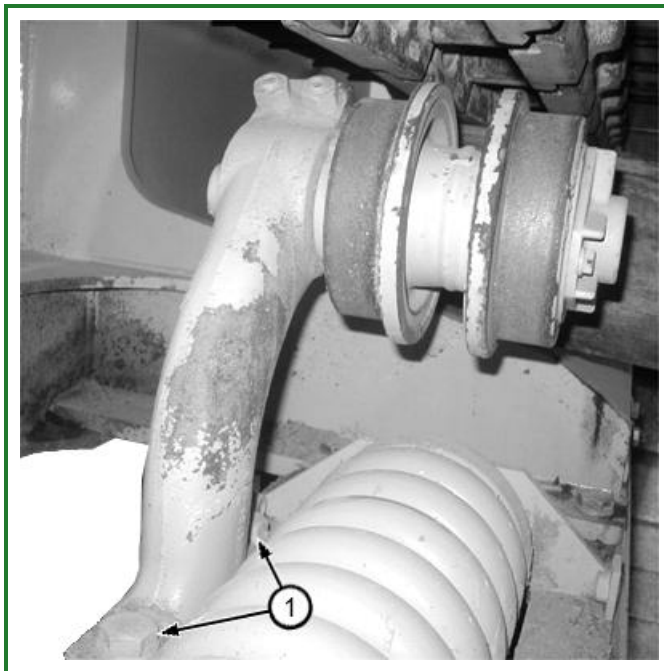

T198433A-UN: Carrier Roller

LEGEND:

1 - Cap Screw (2 used)

Remove cap screws (1) and carrier roller assembly.

6. Measure carrier roller tread diameter.

- See [450J, 550J, 550K Carrier Roller Tread Diameter](#) . (SP326.)
- See [605C, 605K, 650J, 650K Carrier Roller Tread Diameter](#) . (SP326.)

7. Repair or replace parts as necessary. See [Carrier Roller Disassemble and Assemble](#) . (Group 0130.)

8. Install carrier roller and tighten cap screws (1) to specification.

Item	Measurement	Specification
Carrier Roller		
Bracket-to-Frame Cap Screw Torque		620 N·m (460 lb-ft)

9. Adjust track sag. See [Adjust Track Sag](#) . (Operators Manual.)

Carrier Roller Disassemble and Assemble



T198436A-UN: Disassembled Carrier Roller

LEGEND:

- 1 - Bearing Cup (2 used)
- 2 - Roller Shell
- 3 - Seal Retainer
- 4 - Snap Ring
- 5 - Metal Face Seal
- 6 - Bearing Cone
- 7 - Retainer Plate
- 8 - Cap Screw (3 used)
- 9 - Cover
- 10 - Cap Screw (2 used)
- 11 - Shaft
- 12 - Bearing Cone
- 13 - O-Ring

1. Remove bracket from carrier roller (if not removed).
2. Remove cap screws (8) and cover (9).
3. Drain oil from housing.
4. Remove cap screws (10) and retainer plate (7) from shaft (11).
5. Press outer bearing cone (F) and shaft (11) out of roller shell (2) using a press.
6. Press inner bearing cone (12) from shaft (11). Bearing is a press fit.
7. IMPORTANT:

Metal face seals can be reused if they are not worn or damaged. A used seal must be kept together as a set because of wear patterns on seal ring face.

Remove snap ring (4), seal retainer (3) and metal face seals (5). Keep seal rings together as a matched

set with faces together to protect lapped surfaces. Inspect metal face seal. [See Metal Face Seals Inspection](#) . (Group 0130.)

8. Remove bearing cups (1). Inspect roller shell for grooved, burred or galled condition.
9. Replace parts as necessary.
10. Install bearing cups (1) into roller shell, install tight against shoulders.
11. Install inner bearing cone (12) tight against shoulder on shaft. Bearing is a press fit.
12. Install shaft (11) in roller shell.
13. Press outer bearing cone (6) on shaft so bearing is even with end of the shaft.
14. Install retainer plate (7) and cap screws (10). Tighten cap screws to specification.

Item	Measurement	Specification
Carrier Roller		
Carrier Roller Retainer Plate Cap Screws	Torque	47 N·m (35 lb-ft)

15. IMPORTANT:

O-ring and seat surfaces must be clean, dry and oil free so O-rings do not slip when roller is turning.

Thoroughly clean the O-rings and seat surfaces in roller, seal retainer and seal rings using a volatile, non-petroleum base solvent and lint-free tissues.

16. Install one half of metal face seal (5) into seal retainer (3). Install other half of seal into roller shell (2).
17. Apply equal pressure with the fingers at four equally spaced points on seal ring face. O-ring and seal ring should seat squarely in bore.

- 18.

NOTE:

A volatile, non-petroleum base solvent or talcum powder may be used as a lubricant.

Wipe both metal seal ring faces dry with a lint-free tissue.

19. Apply a thin film of oil, as used in the roller, to the shiny sealing area on both metal seal rings.
20. Install seal retainer (3) and snap ring (4) on roller shaft.
21. Fill roller with clean oil. [See Adding Oil To The Roller](#) . (Operator's Manual.)
22. Install cover (9) and cap screws (8). Tighten cap screws to specification.

Item	Measurement	Specification
Carrier Roller		
Carrier Roller Cover Cap Screws	Torque	47 N·m (35 lb-ft)

Go to [Section_01:Group_0130](#)

CED, TX03399, 5938-19-20091216

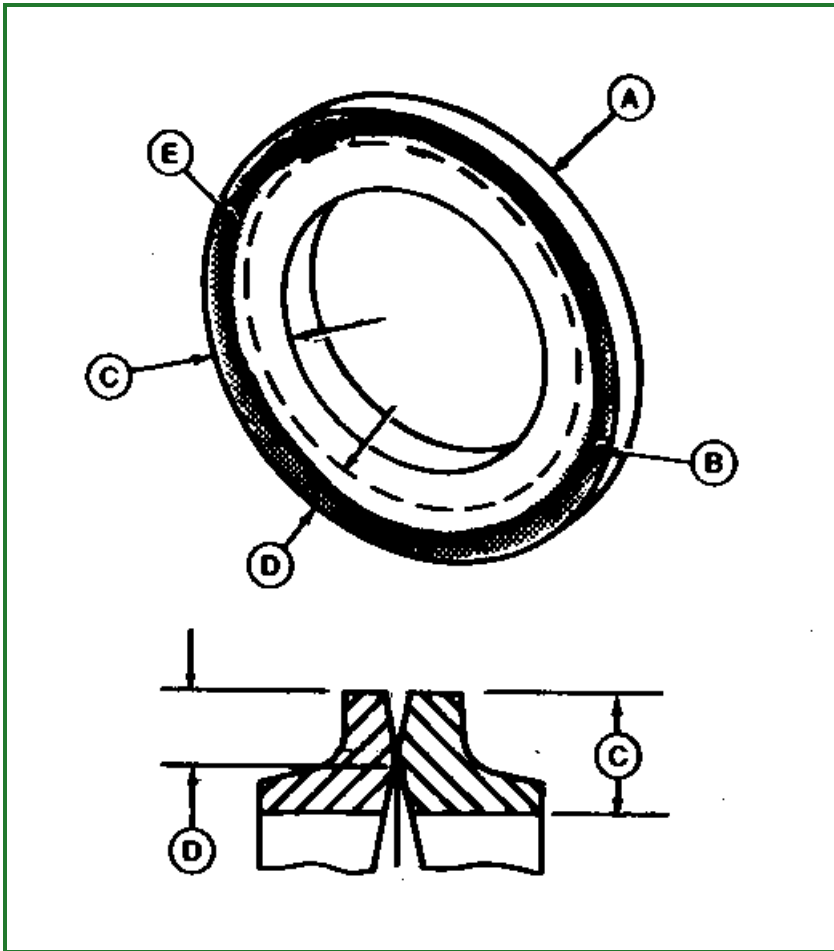
Metal Face Seals Inspection**T85079-UN: Metal Face Seals****LEGEND:**

A - Seal Ring

B - Worn Area (shaded area)

C - Seal Ring Face

D - Outer Half of Seal Ring Face

E - Sealing Area (dark line)

1. Inspect for the following conditions to determine if seals can be reused:

- The narrow, highly polished sealing area (E) must be in the outer half of seal ring face (D).
- Sealing area must be uniform and concentric with the ID and OD of seal ring (A).
- Sealing area must not be chipped, nicked, or scratched.

2.

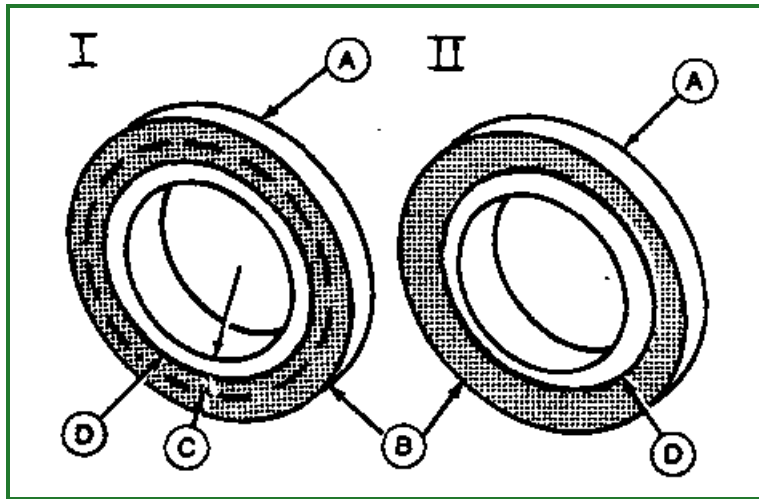

T85080-UN: Cross Section of a Metal Face Seal

LEGEND:

- A - Seal Ring
- B - Worn Area (shaded area)
- C - Inner Half of Seal Ring Face
- D - Sealing Area (dark line)

Illustration shows examples of worn seal rings (A).

I—Sealing area (D) is in inner half of seal ring face (C).

II—Sealing area (D) not concentric with ID and OD of seal ring.

3.

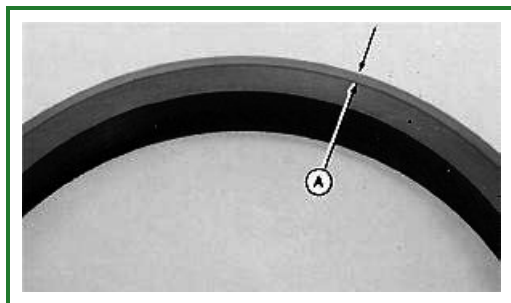

T82840-UN: Seal Face

LEGEND:

- A - Seal Face

Clean reusable seals by removing all foreign material from seal rings, except seal face (A), using a scraper or a stiff bristled fiber brush.

4. Wash seal rings and O-rings using a volatile, non-petroleum base solvent to remove all oil. Thoroughly dry parts using a lint-free tissue.

Apply a thin film of oil to seal ring face. Put face of seal rings together and hold using tape.

Track Roller Remove and Install

1.

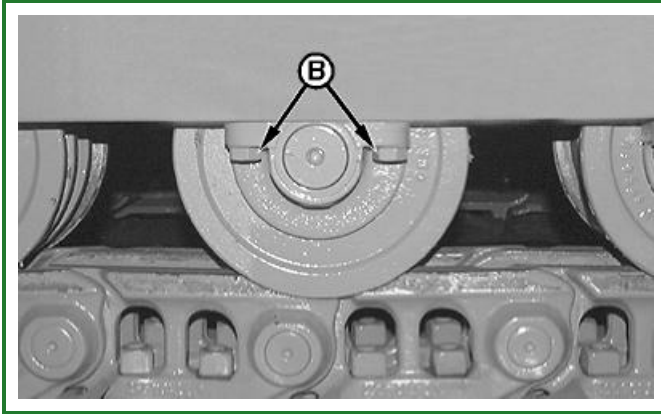

T113330-UN: Roller Bracket Cap Screw

LEGEND:

B - Cap Screw

Track rollers can be removed without disconnecting track. Release track tension to provide sufficient clearance. See [Adjust Track Sag](#) . (Operator's Manual.)

2. If machine is equipped with rock guards, remove outer rock guard and loosen inner rock guard cap screws.

If machine is equipped with chain guides, remove rear chain guide.

3.

⚠ CAUTION:

Prevent possible injury from unexpected machine movement. Put shop stands under frame to support machine while removing lower track roller.

Item	Measurement	Specification
Machine Weight (approximate)	8391 kg	18 500 lb

Raise crawler to provide a clearance for roller removal. Put shop stands under machine.

4. Remove four roller bracket cap screws (B) to remove roller assembly.
5. Measure track roller tread diameter.
- See [450J, 550J, 550K Track Roller Tread Diameter](#) . (SP326.)
 - See [605C, 605K, 650J, 650K Track Roller Tread Diameter](#) . (SP326.)
6. Repair or replace parts as necessary. See [Track Roller Disassemble and Assemble](#) . (Group 0130.)
7. Install roller assembly and tighten cap screws (B).

Item	Measurement	Specification
Track Roller		
Roller Bracket-to-Track Frame Cap Screw Torque		203 N·m 150 lb-ft

Go to [Section_01:Group_0130](#)

CED,OUTX547,73-19-20130408

Track Roller Disassemble and Assemble

1.

NOTE:

Spring pins (A) are tapered on top (flat of bracket). Drive pin out from the bottom.

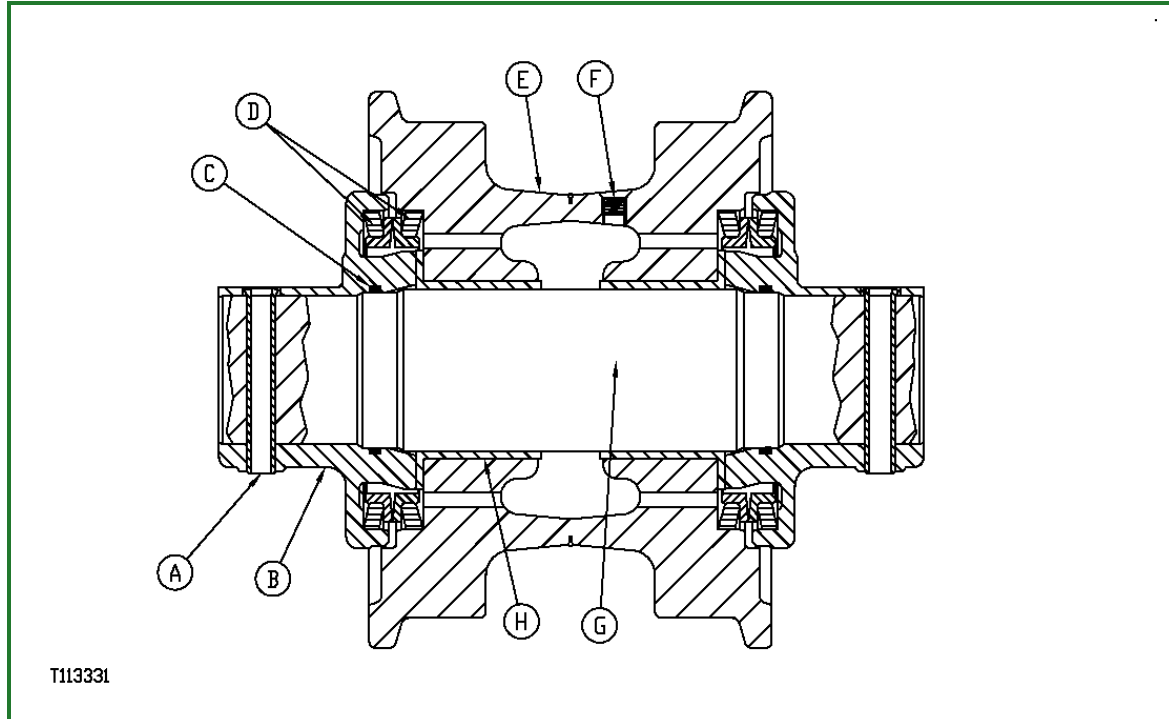

T113331-UN: Cross Section of Track Roller

LEGEND:

- A - Spring Pin (2 used)
- B - Bracket (2 used)
- C - O-Ring (2 used)
- D - Metal Face Seal (2 used)
- E - Roller
- F - Plug
- G - Shaft
- H - Bushing (2 used)

Remove parts (A—D) from both ends of roller.

NOTE:

Bracket, shaft, bushings and roller are serviced as an assembly only.

Avoid damage to metal face seals. Metal face seals can be reused if they are not worn or damaged. A used seal must be kept together as a set because of wear patterns on seal ring face.

2. Remove shaft (G).
3. Inspect shaft bushings, brackets and roller for wear or damage. Replace as an assembly.
4. Lubricate both bushings with oil and install shaft (G).

5. Remove grease from sealing surfaces in roller and roller brackets.
6. Install new metal face seals (D) (if necessary). [See Metal Face Seals Inspection](#) . (Group 0130.)

Install half of seal into roller and other half into bracket.
7. Install O-rings (C) in both brackets.
8. Install brackets (B).
9. Install new spring pins (A) in through top (flat of bracket). Tapered end of pin should be flush with top of bracket.
10. Fill roller with clean oil. [See Adding Oil To The Roller](#) . (Operator's Manual.)

Go to [Section_01:Group_0130](#)

CED,OUTX547,74-19-20080324

Track Roller Leakage Test

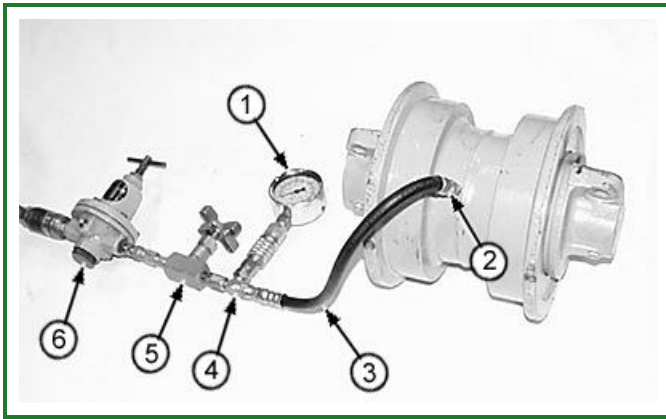
**T118645B-UN: Track Roller Leakage Test****LEGEND:**

- 1 - Pressure Gauge 689 kPa (6.89 bar) (0—100 psi)
- 2 - JT05487 Fitting (1/8 M NPT x 7/16 -20 M 37°)
- 3 - Pressure Hose (7/16 -20 F 37° x 7/16 -20 F 37°)+
- 4 - JT03001 Tee Fitting (7/16 -20 M 37° x 7/16 -20 F 37° Sw x 7/16 -20 M 37°)
- 5 - JT03087 Snubber Valve
- 6 - Regulator

1. Remove plug from track roller.
2. Fill roller with clean oil. [See Adding Oil To The Roller](#) . (Operators Manual.)
3. Turn roller several times to seal metal face seals.
4. Assemble parts (1—6) as shown.
5. Pressurize roller using air to specification and close valve (5).

Item	Measurement	Specification
Track Roller		
Track Roller Leakage Test Pressure		97—138 kPa (0.97—1.38 bar) (14—20 psi)

6. Track roller must maintain air pressure for two minutes. Oil must not leak past metal seals or O-ring. If oil leaks past seals, repair as necessary.
7. Apply pipe sealant to threads of plug.
8. Install and tighten plug.

Go to [Section_01:Group_0130](#)

CED,OUTX547,76-19-20040601

Track Shoe Remove and Install

1.

⚠ CAUTION:

Swamp shoe is heavy and can cause injury if not moved properly. Use adequate lifting device to move swamp shoe.

Item	Measurement	Specification
Track Shoe		
Swamp Shoe	Approximate Weight	25 kg 54 lb

NOTE:

For lubricated chain, cap screws hold a shoe and split master link together.

**T93612-UN: Right Angle Attachment and Ruler**

Measure grouser height of several track shoes to find an average using a depth gauge such as the JT05521 200 mm Ruler, JT05534 Right Angle Attachment and D05231ST 300 mm Ruler from JT05518 or JT05523 Undercarriage Inspection Service Tool Kit.

- See 450J, 550J, 550K Single Bar Grouser Height . (SP326.)
- See 450J, 550J, 550K Two Bar Grouser Height . (SP326.)
- See 450J, 550J, 550K Three Bar Grouser Height . (SP326.)
- See 650J, 650K Single Bar Grouser Height . (SP326.)

2.

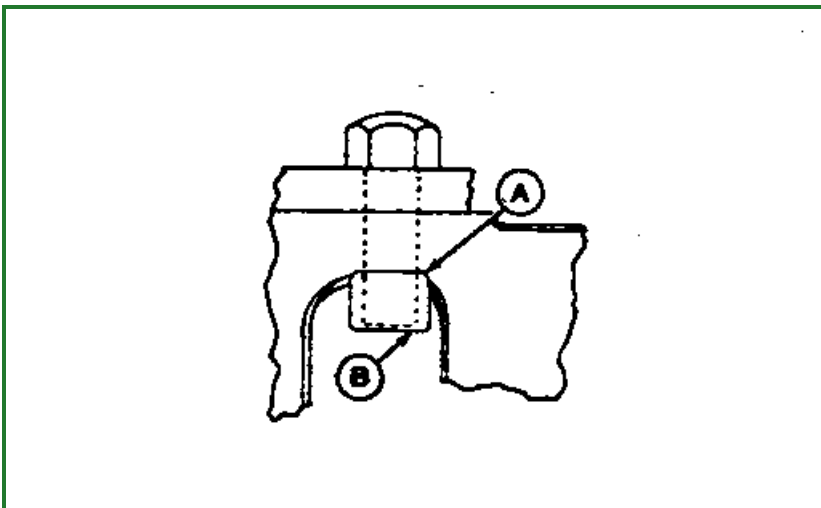

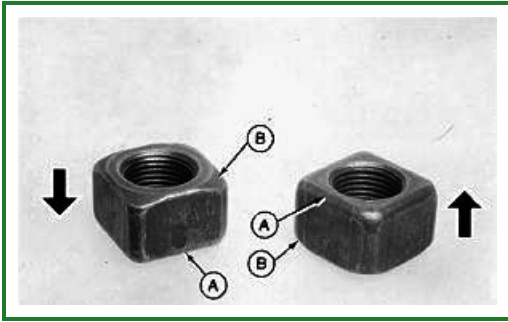
T96291-UN: Rounded and Chamfered Edges**T96292-UN: Rounded and Chamfered Edges****LEGEND:**

- A - Cap Screw Rounded Edges
- B - Cap Screw Chamfered Edges

Remove nuts using DF1041. [See DF1041 Track Nut Removal Tool](#) . (Group 9900.) Remove cap screws and shoes.

3. Before installing shoes, clean paint, dirt and debris from mounting surfaces of shoes and links.
4. For all cap screws except master split link and track shoe cap screws, apply SAE 30W oil to threads and bearing surface under head.

For master split link and track shoe cap screws, apply PM37566 Loctite Silver Anti-Seize Lubricant **LOCTITE®** (or equivalent) to threads and surface under head.

5. **IMPORTANT:**

Never use an impact wrench to start cap screws in a split master link to avoid cross-threading.

Install new cap screws. Install new nuts with rounded edges (A) against link and chamfered edges (B) away from link.

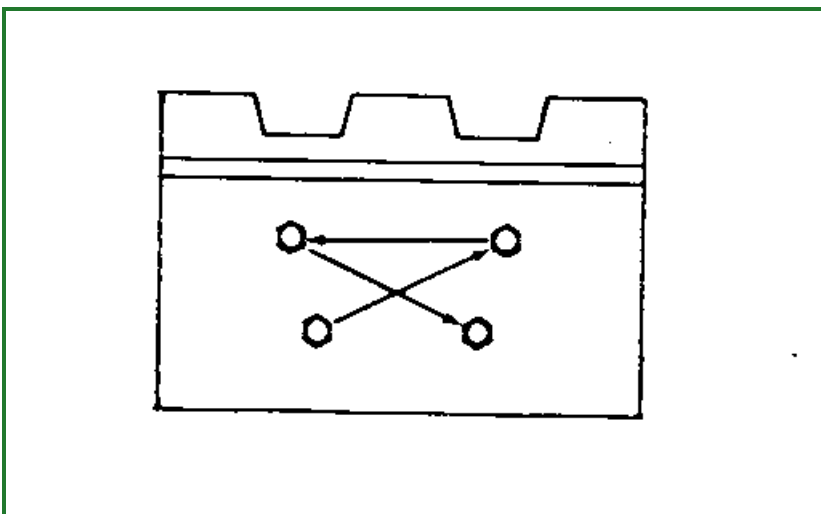
6. **IMPORTANT:****T6352AH-UN: Track Shoe Cap Screws**

Tighten cap screws to torque specification using a criss-cross pattern. Then repeat torque pattern again.

Check torque after 50—100 hours of operation to be sure cap screws are tightened to specified torque. If not, repeat steps 2—5.

Item	Measurement	Specification
Track Shoe		
450J and 550J Track Shoe Cap Screw (9/16 in.)	Torque	88 N·m Second Pass—Additional 1/3 (120°) turn 65 lb-ft Second Pass—Additional 1/3 (120°) turn
650J and 605C Track Shoe Cap Screw (5/8 in.)	Torque	190 N·m Second Pass—Additional 1/3 (120°) turn 140 lb-ft Second Pass—Additional 1/3 (120°) turn
450J and 550J Master Split Link Cap Screw (9/16 in.)	Torque	88 N·m Second Pass—Additional 1/2 (180°) turn 65 lb-ft Second Pass—Additional 1/2 (180°) turn
650J and 605C Master Split Link Cap Screw (5/8 in.)	Torque	190 N·m Second Pass—Additional 1/2 (180°) turn 140 lb-ft Second Pass—Additional 1/2 (180°) turn

Go to [Section_01:Group_0130](#)

CED,OUTX547,78-19-20130401

Sealed Track Chain Removal

1.

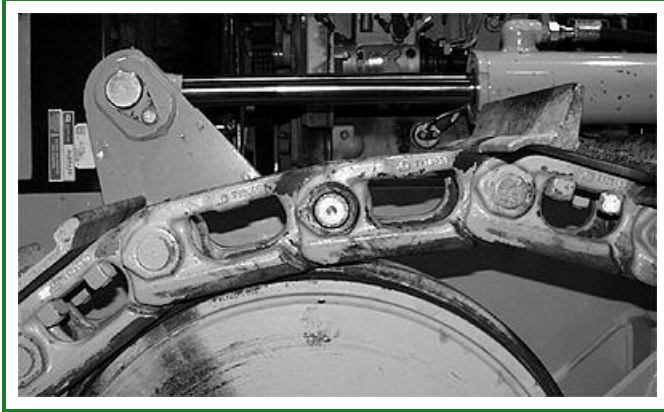

T118662B-UN: Track Chain Master Pin

Rotate track to position, the master pin on the front idler at approximately a twelve o'clock position to clear C-frame.

NOTE:

Master pin is identified by drill point in end of pin.

2.

⚠ CAUTION:

Make sure track is off floor before rotating.

Remove track shoes on each side of master pin. [See Track Shoe Remove and Install](#) . (Group 0130.)

3.

⚠ CAUTION:

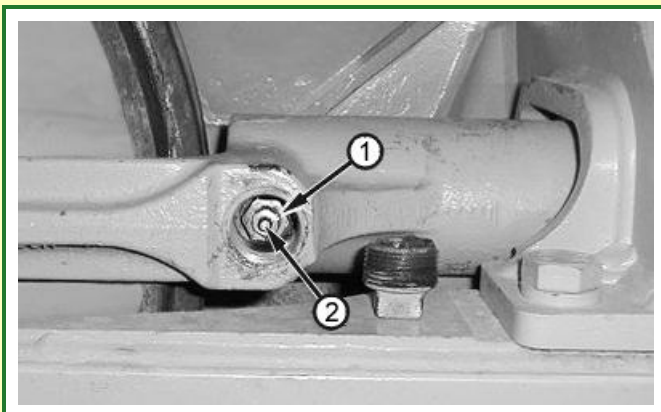

T118012C-UN: Track Adjuster

LEGEND:

1 - Check Valve

2 - Grease Fitting

Grease for track adjuster cylinder is under high pressure. Never remove special high pressure fitting (2) to release the grease.

If grease does not escape immediately from vent hole when relief or check valve

is open, slowly drive machine forward and reverse until grease escapes; then close relief or check valve.

Release track tension:

1. Turn check valve (1) one to three turns counterclockwise to release grease through vent hole.
2. DO NOT loosen special grease fitting (2).
3. Tighten valve.

4. IMPORTANT:

Do not remove the track master pin with a hammer. This will enlarge the link pin bore requiring installation of a new track link.

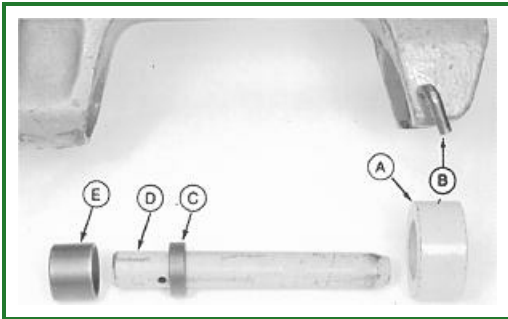

T93556-UN: Master Pin Components

LEGEND:

- A - Aligning Adapter
- B - Holding Screw
- C - Aligning Bushing
- D - Forcing Pin
- E - Pin Adapter

Remove master pin from track link using master pin pusher. Install aligning adapter (A) into master pin pusher C-frame securing with holding screw (B). Put aligning bushings (C) over forcing pin (D) and install adapter (E) in C-frame.

5.

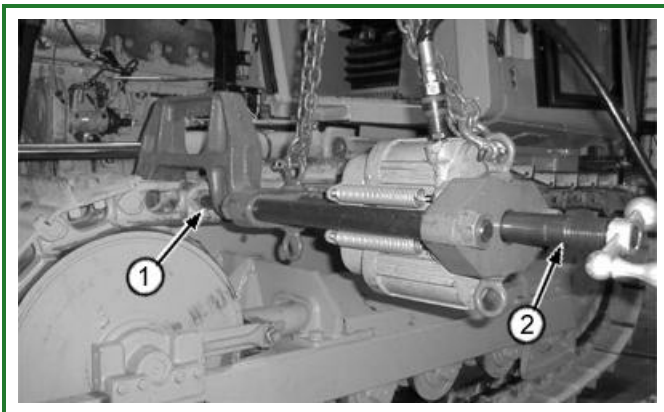

T118576B-UN: Ram Adjusting Screw and Forcing Pin

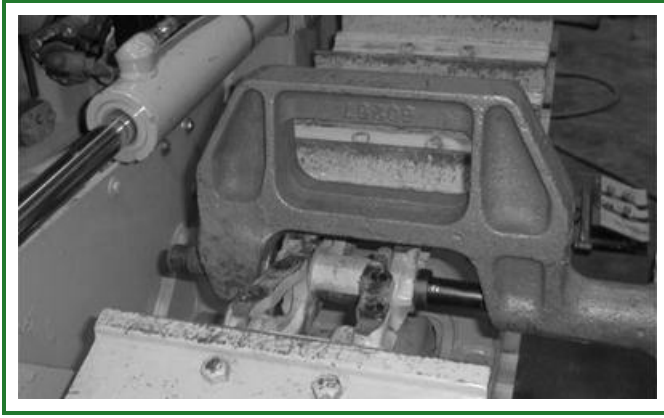

T118577B-UN: Master Pin Pusher and Forcing Pin

LEGEND:

- 1 - Forcing Pin
- 2 - Ram Adjusting Screw

Position master pin pusher and forcing pin in alignment with master pin using load positioning sling and hoist.

6. Turn ram adjusting screw (2) clockwise with crank until forcing pin (1) contacts master pin.
7. Connect hand pump to pin pusher. Activate pump to remove master pin.
8. Remove forcing pin to separate track.

9.



T93558-UN: Spacers and Seals

LEGEND:

- A - Washer (4 used)
- B - Spacer (2 used)

Pull track chain apart. Remove spacers (B) and washers (A) from between left and right track links.

10.

⚠ CAUTION:

Prevent possible injury from unexpected machine movement. Put shop stands under frame to support machine while removing lower track roller.

Item	Measurement	Specification
Machine Approximate Weight	8391 kg	18 500 lb

Place a jack under both crossbars and raise crawler to provide clearance. Put shop stands under

machine.

11. Operate crawler and rotate track in the reverse direction. Slowly, unwrap track off drive sprocket.

12. Measure track link height.

- See 450J, 550J, 550K Link Height . (SP326.)
- See 605C, 605K, 650J, 650K Link Height . (SP326.)

13. Measure track chain pitch.

- See 450J, 550J, 550K Chain Pitch . (SP326.)
- See 605C, 605K, 650J, 650K Chain Pitch . (SP326.)

14. Measure track bushing outer diameter.

- See 450J, 550J Bushing Outer Diameter—Sealed Dry Chain, Normal Impact Applications . (SP326.)
- See 450J, 550J Bushing Outer Diameter—Sealed Dry Chain, High Impact Applications . (SP326.)
- See 650J Bushing Outer Diameter—Sealed Dry Chain, Normal Impact Applications . (SP326.)
- See 650J Bushing Outer Diameter—Sealed Dry Chain, High Impact Applications . (SP326.)

15.

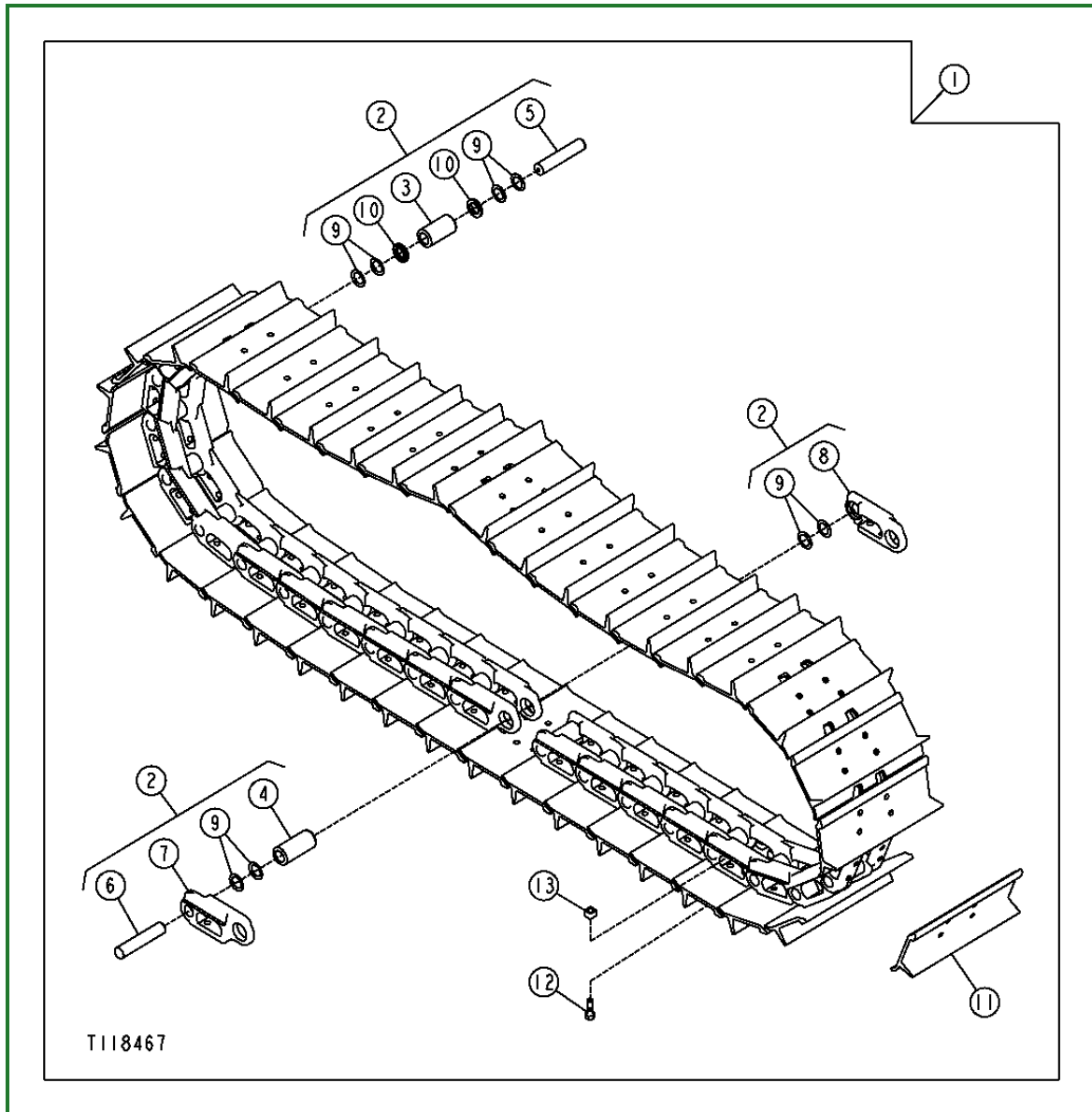

T118467

T118467-UN: Track Chain and Links**LEGEND:**

- 1 - Track Chain Assembly
- 2 - Track Link Assembly
- 3 - Master Bushing
- 4 - Bushing
- 5 - Master Pin (Drilled Point on Ends)
- 6 - Pin
- 7 - Track Link
- 8 - Track Link
- 9 - Washers
- 10 - Spacers
- 11 - Shoes
- 12 - Cap Screws
- 13 - Nuts

Repair or replace parts as necessary.

Go to [Section_01:Group_0130](#)

CED,OUTX547,83-19-20091216

Sealed Track Chain Disassemble and Assemble

1. Sealed track must be removed and disassembled to turn pins and bushings. [See Sealed Track Chain Removal](#) . (Group 0130.)
2. See your track press manufacturers operator's manual to disassemble and assemble sealed track chain.

Use the following tooling:

450H, 450J, 550H, and 550J:

- Tooling Set A2656-139
- Saddle 40989

650H, 650J, and 605C:

- Tooling Set A2656-139
- Saddle 42101 [For stepped bushing design, use 052657-001 saddle.]

3.

NOTE:

Wear on pins and bushings does not extend over the entire surface. Turning pins and bushings is determined by the amount of wear.

Turn pins and bushings as required. [See Turning Pins and Bushings on Sealed Track Chain](#) . (SP326.)

4. Assemble track chain and install on machine. [See Sealed Track Chain Installation](#) . (Group 0130.)

Go to [Section_01:Group_0130](#)

CED,TX03399,5073-19-20060908

Sealed Track Chain Installation

1. IMPORTANT:

Track chain MUST be installed under track frame with wide end of links toward rear of machine or accelerated wear to track chain will occur.

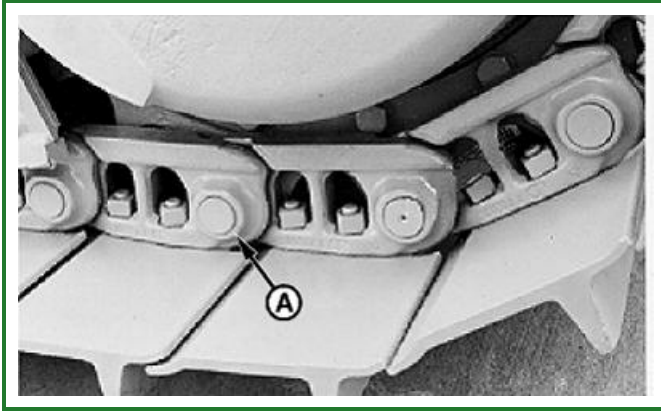

T118611-UN: Drive Sprocket End Shown

LEGEND:

A - Link

Position track chain under crawler with wide part of links (A) toward rear of crawler.

2.

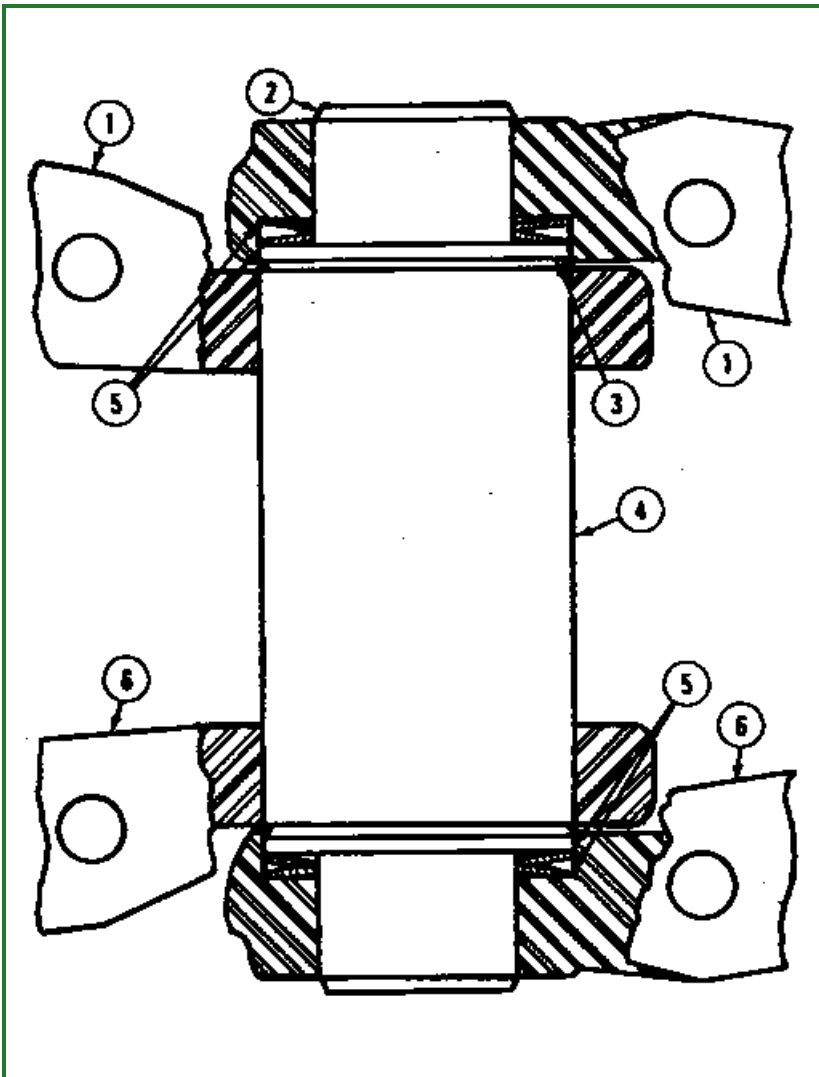

T6043AR-UN: Cross Section of Track Chain

LEGEND:

- 1 - Right Track Link
- 2 - Forcing Pin
- 3 - Master Bushing Spacer
- 4 - Master Bushing
- 5 - Seals
- 6 - Left Track Link

Put end of chain on sprocket then slowly turn sprocket in forward direction to pull chain across top of frame to front idler.

- 3. Put two seals (5) into counterbore of end link with seal inside diameters touching.
- 4. Install master bushing spacers (3) with flat side against seal and push end links together.
- 5. Install forcing pin to align links (1 and 6), bushing (4), seals (5), and spacers (3).

6.

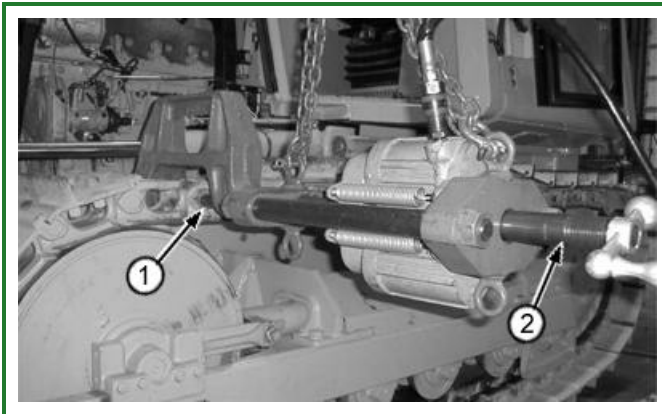

T118576B-UN: Pin Pusher, Guide Pin and Adapter

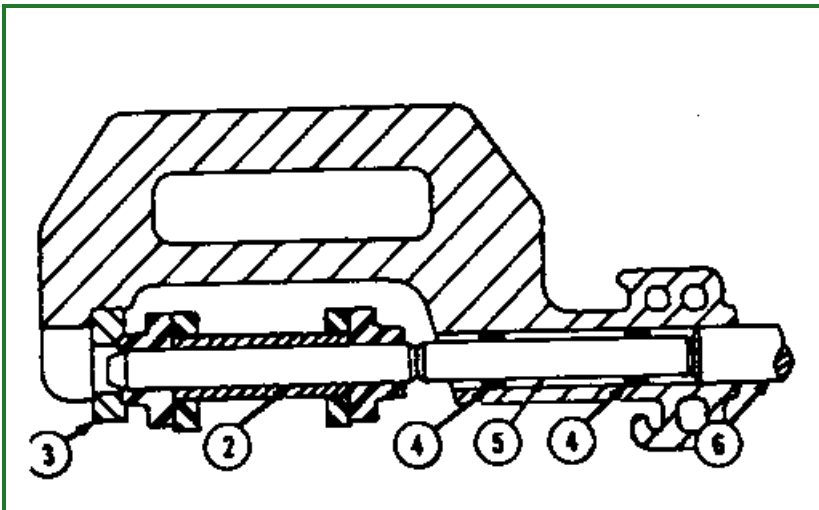

T6043AQ-UN: Master Pin Assembly

LEGEND:

- 1 - 100 Ton Master Pin Pusher
- 2 - Guide Pin
- 3 - Aligning Adapter
- 4 - Aligning Bushings
- 5 - Master Pin

6 - Rear Forcing Pin

Apply oil to master pin (5).

7. Position master pin pusher (1) on track.

8. Press master pin (5) into end links.

NOTE:

If master pin does not fit securely into links, an oversize master pin is recommended.

9. Install track shoes. [See Track Shoe Remove and Install](#) . (Group 0130.)

10. Adjust track sag. [See Adjust Track Sag](#) . (Operators Manual.)

Go to [Section_01:Group_0130](#)

CED,OUTX547,85-19-20040601

Lubricated Track Chain (Saw Tooth Master Split Link) Remove and Install

1.

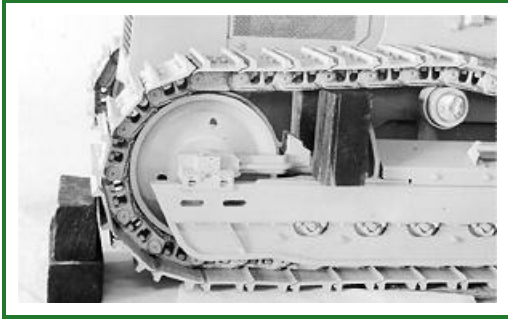

T8055BG-UN: Block at Front Idler

Rotate track until split link pin is at the top of front idler.

2. Block track at front idler.

3. Put a block on top of recoil spring cover, near front idler to keep chain supported.

4.

⚠ CAUTION:

Grease for track adjuster cylinder is under high pressure. Never remove special high pressure grease fitting (2) to release the grease.

If grease does not escape immediately from vent hole (3), the check valve is open. Slowly drive machine forward and reverse until grease escapes; then close check valve.

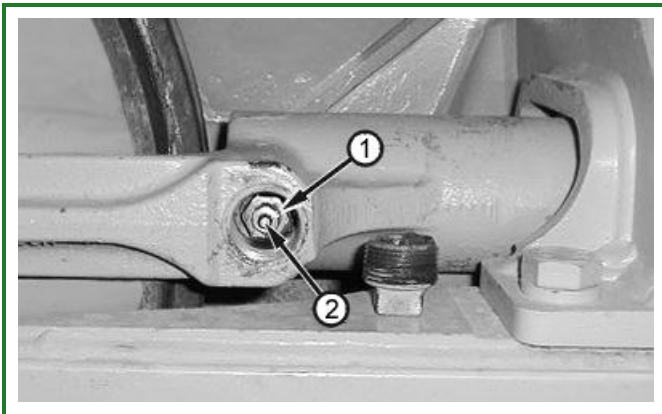

T118012C-UN: Track Adjuster

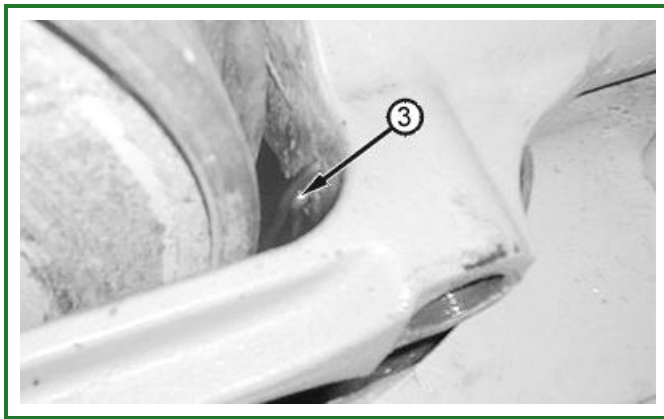

T118013C-UN: Vent Hole

LEGEND:

- 1 - Check Valve
- 2 - Grease Fitting
- 3 - Vent Hole

Release track tension:

1. Check valve (1) one to three turns counterclockwise to release grease through vent hole (3). DO NOT loosen special grease fitting (2).
2. Tighten valve.

5.

⚠ CAUTION:

Track chain will fall to the ground when removing cap screws from shoe to separate master link. DO NOT stand at end of track.

Remove track shoe at master split link. [See Track Shoe Remove and Install](#) . Group 0130.)

6.

⚠ CAUTION:

Prevent possible injury from unexpected machine movement. Put shop stands under frame to support machine while removing lower track roller.

Item	Measurement	Specification
Machine Approximate Weight		8391 kg 18 500 lb

Place a jack under both crossbars and raise crawler to provide clearance. Put shop stands under machine.

7. Operate crawler and rotate track in the reverse direction. Slowly, unwrap track off drive sprocket.
8. Measure track link height.
 - [See 450J, 550J, 550K Link Height](#) . (SP326.)
 - [See 605C, 605K, 650J, 650K Link Height](#) . (SP326.)
9. Measure track chain pitch.

- See 450J, 550J, 550K Chain Pitch . (SP326.)
- See 605C, 605K, 650J, 650K Chain Pitch . (SP326.)

10. Measure track bushing outer diameter.

- See 450J, 550J, 550K Step Bushing Outer Diameter—Normal Impact Applications . (SP326.)
- See 450J, 550J, 550K Step Bushing Outer Diameter—High Impact Applications . (SP326.)
- See 450J, 550J SC-2™ Extended Life Step Bushing Outer Diameter—Normal Impact Applications . (SP326.)
- See 450J, 550J SC-2™ Extended Life Step Bushing Outer Diameter—High Impact Applications . (SP326.)
- See 450J, 550J, 550K SC-2™ Maximum Life Step Bushing Outer Diameter—Normal Impact Applications . (SP326.)
- See 450J, 550J, 550K SC-2™ Maximum Life Step Bushing Outer Diameter—High Impact Applications . (SP326.)
- See 605C, 605K, 650J, 650K Step Bushing Outer Diameter—Normal Impact Applications . (SP326.)
- See 605C, 605K, 650J, 650K Step Bushing Outer Diameter—High Impact Applications . (SP326.)
- See 605C, 605K, 650J, 650K SC-2™ Extended Life and Maximum Life Step Bushing Outer Diameter—Normal Impact Applications . (SP326.)
- See 605C, 605K, 650J, 650K SC-2™ Extended Life and Maximum Life Step Bushing Outer Diameter—High Impact Applications . (SP326.)

11. IMPORTANT:

Track chain MUST be installed under track frame with wide end of links (A) toward rear of machine or accelerated wear to track chain will occur.

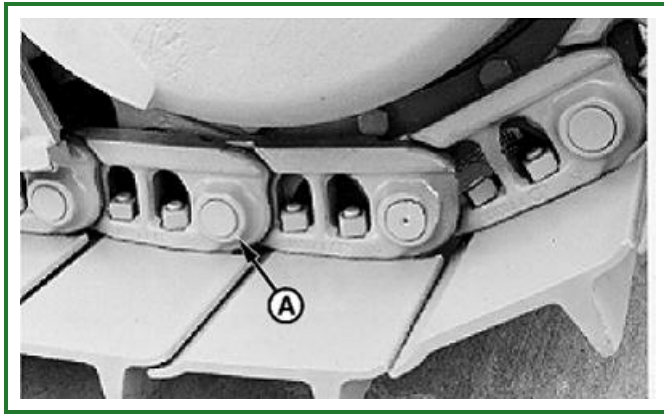

T118611-UN: Drive Sprocket End Shown

To join master link, locate master link pin end at the top of the front idler. Put a block at the front of the idler.

12. Apply PM37566 Loctite Silver Anti-Seize Lubricant LOCTITE® to mating surfaces of master link.
13. Use a come-along device to bring master link halves together.
14. Install shoe and new caps screws. Apply PM37566 Loctite Silver Anti-Seize Lubricant LOCTITE® (or equivalent) to threads and surface under head. Start cap screws by hand to avoid cross-threading.

IMPORTANT:

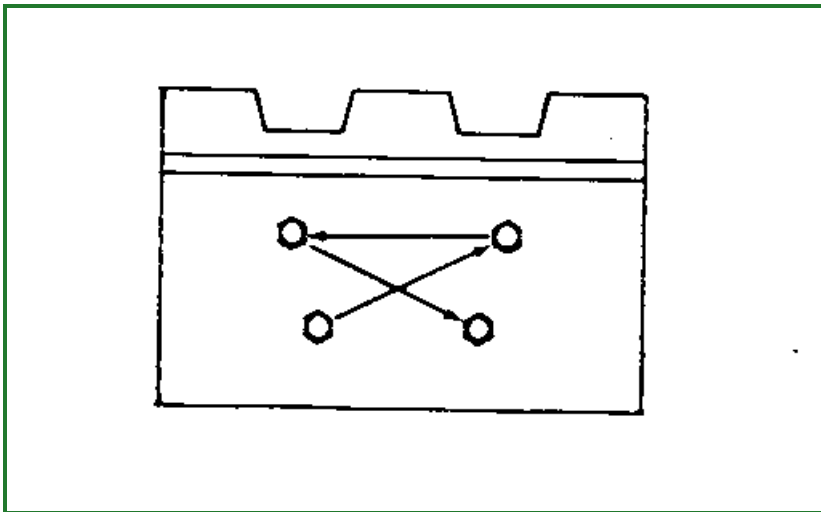

T6352AH-UN: Track Shoe/Split Link Cap Screws

Tighten cap screws to the initial torque using a criss-cross pattern. Repeat pattern for a second time. Finally, turn each cap screw the additional turn using the same pattern.

Item	Measurement	Specification
Track Shoe		
450J and 550J Track Shoe Cap Screw (9/16 in.)	Torque	88 N·m Second Pass—Additional 1/3 (120°) turn 65 lb-ft Second Pass—Additional 1/3 (120°) turn
650J and 605C Track Shoe Cap Screw (5/8 in.)	Torque	190 N·m Second Pass—Additional 1/3 (120°) turn 140 lb-ft Second Pass—Additional 1/3 (120°) turn
450J and 550J Master Split Link Cap Screw (9/16 in.)	Torque	88 N·m Second Pass—Additional 1/2 (180°) turn 65 lb-ft Second Pass—Additional 1/2 (180°) turn
650J and 605C Master Split Link Cap Screw (5/8 in.)	Torque	190 N·m Second Pass—Additional 1/2 (180°) turn 140 lb-ft Second Pass—Additional 1/2 (180°) turn

Go to [Section_01:Group_0130](#)

CED,OUTX547,87-19-20130401

Lubricated Track Chain Disassembly (Turn Bushings and Lubricate Chain)

NOTE:

The following procedure is for disassembly of track chain to inspect, clean, replace damaged or worn parts, turn bushings, and re-lubricate chain.

If track chain is disassembled only to turn pins and bushings and no parts will be replaced, see [Lubricated Track Chain Disassemble and Assemble \(Turn Pins and Not Lubricate\)](#) . (Group 0130.)

1. Remove track shoes and track chain.

- See [Track Shoe Remove and Install](#) . (Group 0130.)
- See [Lubricated Track Chain \(Saw Tooth Master Split Link\) Remove and Install](#) . (Group 0130.)

2.

NOTE:

A clean track is necessary for proper disassembly.

Wash chain with high pressure water. It will not be necessary to wash links before reassembly if chain is thoroughly cleaned.

3. Use the following track press tool sets:

450J and 550J:

- Tooling Set A2656-213
- Saddle 40989

650J:

- Tooling Set A2656-217
- Saddle 42101 [For stepped bushing design, use saddle 052657-001.]

4. IMPORTANT:

Track press disassembly tools must be in proper alignment with links to prevent broaching of pin and bushing. Damaged link bores cannot be reused.

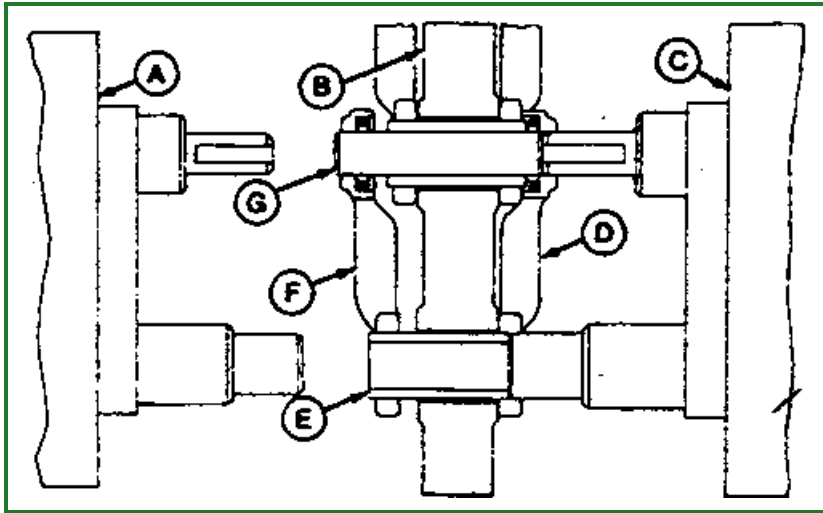

T96266-UN: Removing Right Pin Bushings

LEGEND:

- A - Left Ram
- B - Saddle
- C - Right Ram
- D - Right Link
- E - Bushing
- F - Left Link
- G - Pin

Start disassembly at pin-end half of split link. Check for proper alignment of tools with pin and bushing.

5. Make an index mark on bushings to aid in reassembly, when turning bushings 1/2 turn (180°) to expose a new wear surface.

6.

⚠ CAUTION:

Always wear safety glasses when operating the press. Parts may break or chip, which could create a risk of personal injury.

Extend right ram (C) to push pin (G) and bushing (E) from the right link (D). The right link is forced against the side of saddle (B) as pin and bushing are pushed out.

7. Retract right ram. The right link, with seals and thrust ring, will stay on the ram tools.

8.

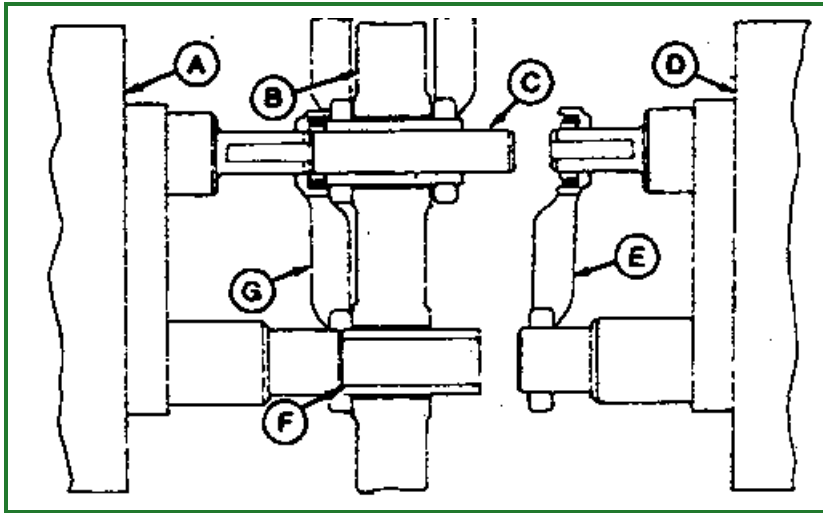

T96267-UN: Remove Left Pin Bushing

LEGEND:

- A - Left Ram
- B - Saddle
- C - Pin
- D - Right Ram
- E - Right Link
- F - Bushing
- G - Left Link

Extend left ram (A) to push the pin (C) and bushing (F) from left link (G). The left link is forced against the side of saddle (B) as pin and bushing are pushed out.

- 9. Retract left ram. The left link, with seal and thrust ring, will remain on the ram tools.
- 10. Remove links, bushing, and thrust rings from press.

11.

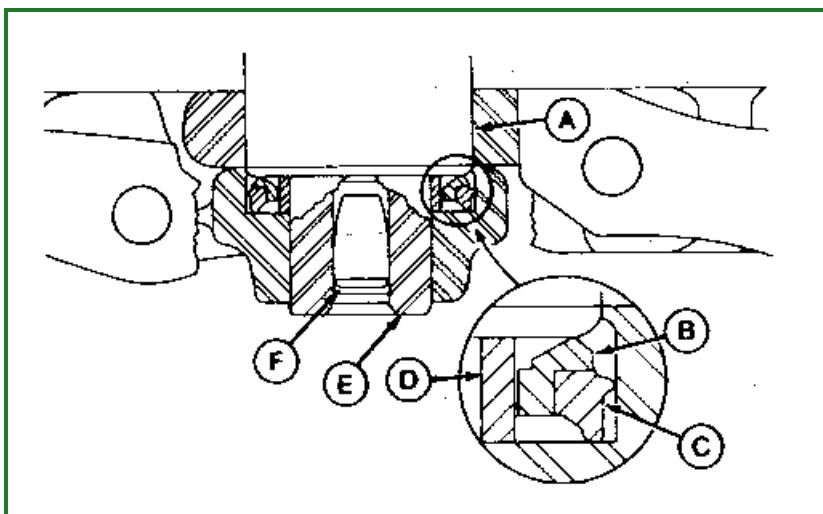

T6682AJ-UN: Removing Rubber Stopper

LEGEND:

- A - Bushing
- B - Seal Ring
- C - Load Ring
- D - Thrust Ring

E - Pin

F - Stopper

Inspect parts as they are disassembled to determine which ones can be reused.

If there is internal wear at any joint, replace seal ring, pin, bushing, thrust ring, and load ring. These parts must be replaced to successfully re-lubricate chain.

12. If pin and bushing contains oil when disassembled, new pins, seal rings, bushings, thrust ring and load rings are not necessary. Do not remove usable seals from link counterbore. Do not remove any dirt from around seals.
13. Repeat steps to disassemble rest of chain.
14. Remove rubber stopper (F) from pins using a drill.

15.

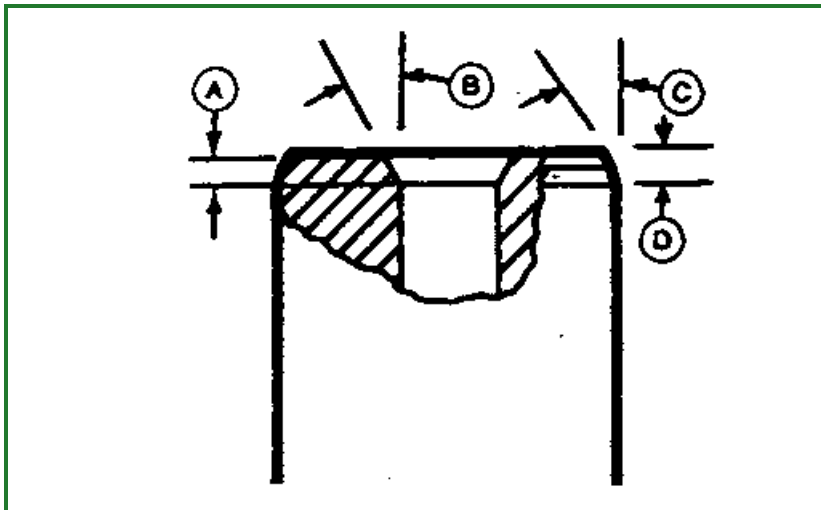

T96269-UN: Pin Chamfer

LEGEND:

A - 4 mm (0.16 in.)

B - 30°

C - 10°

D - 3 mm (0.12 in.)

Inspect pin ends. If the chamfer is missing due to wear, grind a 3 mm (0.12 in.) x 10° chamfer on pin. If chamfer is missing in stopper hole, add new 4 mm (0.16 in.) x 30° chamfer.

Item	Measurement	Specification
Lubricated Track		
Pin	Chamfer	3 mm x 10° (0.12 in.) x 10°
Pin	Chamfer	4 mm x 30° (0.16 in.) x 30°

16. Clean pins, bushings, and thrust rings in solvent.

Lubricated Track Chain Assembly (Turn Bushings and Lubricate Chain)**-: Specifications**

SPECIFICATIONS	
450J and 550J Pressure Relief Valve Setting Force (Maximum)	284 088 N (63 840 lb force)
650J Pressure Relief Valve Setting Force (Maximum)	355 110 N (79 800 lb force)
450J and 550J Bushing Protection Distance	1.63—2.13 mm (0.064—0.084 in.)
650J Bushing Protection Distance	1.45—1.96 mm (0.057—0.077 in.)
Gauge Vacuum	68—102 kPa (20—30 in. Hg)
Oil Pressure	140—205 kPa (1.4—2.0 bar) (20—30 psi)

-: Essential Tools

ESSENTIAL TOOLS
JDG589 Stopper Installer
D0890 Seal Tester and Lubricator [Order from: Centurin Industries Inc., 45 Capitol Dr., Oconomowoc, WI]
A2679 Nozzle [Order from: Centurin Industries Inc., 45 Capitol Dr., Oconomowoc, WI]

-: Service Equipment and Tools

SERVICE EQUIPMENT AND TOOLS
A2656—213 Lubed Track Tool Set
40989 Saddle
A2656-217 Lubed Track Tool Set
42101 Saddle

-: Other Material

OTHER MATERIAL
277 Loctite® Thread Lock and Sealer (high strength)

⚠ CAUTION:

Prevent possible injury from unexpected machine movement. Make sure all control levers of press are in the NEUTRAL position.

1.

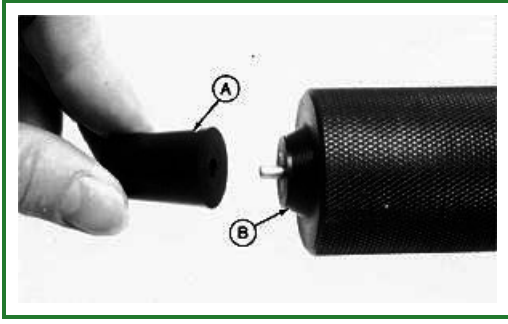

T96272-UN: Stopper and Stopper Installer

LEGEND:

A - Stopper

B - Stopper Installer

Assemble track using following track press tool sets.

450J and 550J:

- Tooling Set A2656-213
- Saddle 40989

650J:

- Tooling Set A2656-217
- Saddle 42101 [For stepped bushing design, use 052657-001 saddle.]

2. Apply a mixture of 50% alcohol and 50% water to stopper (A) and install using JDG589 Stopper Installer (B).

3.

NOTE:

The pin end halves of master split link must be temporarily assembled to bushing end halves of link for proper positioning on plungers. Pin end halves will have to be separated later for installation at end of chain. Split links are a matched set and must be assembled as a set.

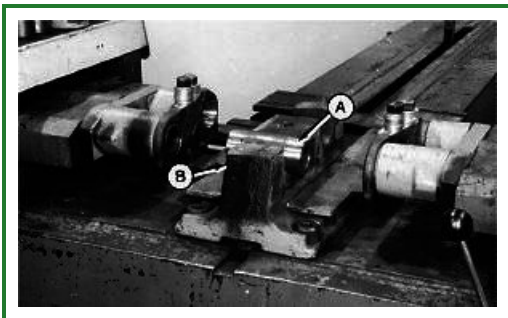

T96273-UN: Bushing and Front Seat Of Saddle

LEGEND:

A - Bushing

B - Saddle

Assemble master split link halves using master shoe bolts and washers (as required). Tighten bolts just enough to hold links together.

4. Install assembled split links on ram plungers.
5. Install bushing (A) in front seat of saddle (B) so the mark is 180° opposite original location to expose a new wear surface.

6.



T96274-UN: Relief Valve Adjustment

Adjust track press pressure relief valve setting.

Item	Measurement	Specification
Lubricated Track		
450J and 550J Pressure Relief Valve Setting	Force (Maximum)	284 088 N (63 840 lb force)
650J Pressure Relief Valve Setting	Force (Maximum)	355 110 N (79 800 lb force)

7. Advance left ram until left split link contacts saddle. Advance right ram until it stops to press split link and bushing assembly together.

8.



T96275-UN: Bushing Projection Measurement

Measure bushing projection from shoulder of link using a depth micrometer. Bushing projection determines clearance between overlapping links and proper spacing of link bolt holes.

Item	Measurement	Specification
Lubricated Track		
450J and 550J Bushing Protection	Distance	1.63—2.13 mm (0.064—0.084 in.)
650J Bushing Protection	Distance	1.45—1.96 mm (0.057—0.077 in.)

9. If bushing projection does not meet specification, check pressure setting or adjust shim packs behind plungers. Only first two joints must be checked for proper bushing projection.

10.



T96276-UN: Lubricant Application

Apply track chain lubricant to bushing ends before next set of links are installed.

11. IMPORTANT:

Pins must be installed so cross-drilled hole is toward link wear surface or they may break when chain is used. To make assembly easier, install all pins so holes in end are toward same side of chain.

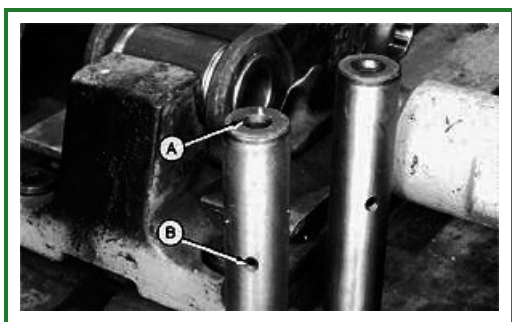

T96277-UN: Cross-Drilled and Pin Hole

LEGEND:

A - Cross-Drilled Hole

B - Cross-Drilled Hole

Install pin in bushing so cross-drilled hole (B) is toward link wear surface. Install all pins so hole (A) in end is toward same side of chain, either left or right.

12.



T96278-UN: Thrust Ring Installation

Install a thrust ring on each end of pin.

13. Move completed split link assembly to rear seat of saddle.

14.



T96279-UN: Thread Lock and Sealer (high strength) Application

Apply PM38656 Thread Lock and Sealer (high strength) to link bore. The sealant prevents loss of vacuum or lubricant leakage through pin to link joint.

15.

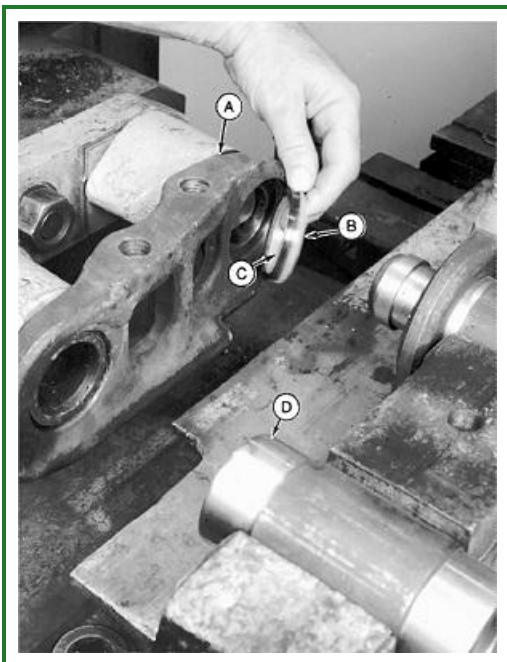

T7158AU-UN: Counterbore, Bushing, Seal & Load Rings

LEGEND:

A - Link Counterbore

B - Seal Ring

C - Load Ring

D - Bushing

Install bushing (D) in front saddle seat. Install left link (A) and right link on ram plungers.

Assemble load ring (C) and seal ring (B). Install assembly into link (A) counterbore so pointed lip of seal ring is toward bushing (D).

16.

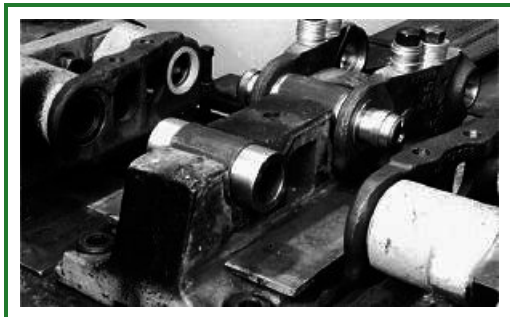

T96282-UN: Installing Right and Left Links

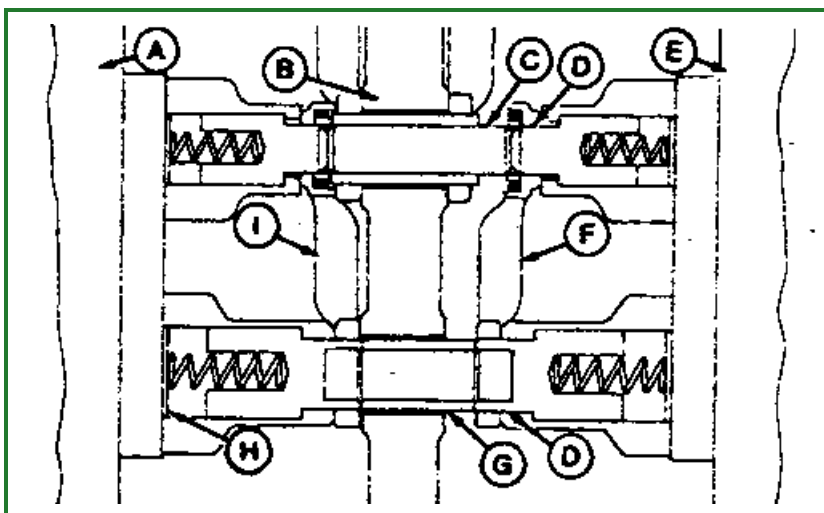

T96283-UN: Installing Right and Left Links

LEGEND:

- A - Left Ram
- B - Saddle
- C - Pin
- D - Plunger
- E - Right Ram
- F - Right Link
- G - Bushing
- H - Shims
- I - Left Link

Advance left ram until left link contacts saddle. Advance right ram until it stops (plungers in both rams against shim pack).

17.

NOTE:

To ensure zero end play in joint, special spacers must be fabricated using a section of bushing.

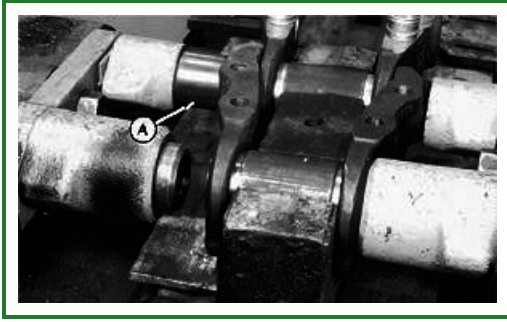

T96284-UN: Special Spacer

LEGEND:

A - Special Spacer

Retract left ram. Install special spacer (A) between the joint in rear seat of saddle and ram.

18. **IMPORTANT:**

Too much pressure will crush the thrust rings.

Advance left ram using only minimum force required to push joint tight. Pressure must be approximately one-half the relief valve setting.

19.



T96285-UN: Pry Link Assemblies

After one complete joint has been assembled, check end play of track links to make sure bushing, thrust rings, and link counterbore faces are pressed solid against each other. Position base of dial indicator on one link assembly and pointer against the other link assembly.

20. Pry link assemblies in one direction then in opposite direction to measure the amount of end play. End play must be zero.

21. As track chain is being further assembled, end play may be checked by flexing each joint after each link assembly is pressed together. End play is correct if links cannot be rotated by hand.

22.

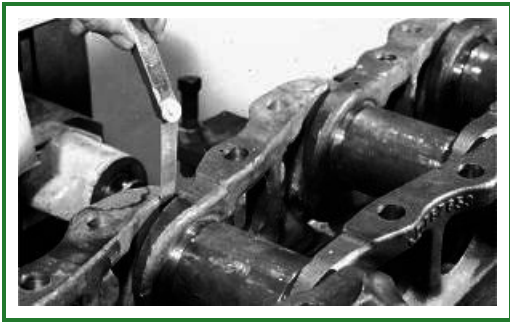

T96286-UN: Overlapping Measurement

As chain is being assembled, check to make sure there is some clearance between the overlapping face of links, using a feeler gauge. If links contact each other, check bushing projection.

Item	Measurement	Specification
Lubricated Track		
450J and 550J Bushing Protection	Distance	1.63—2.13 mm (0.064—0.084 in.)
650J Bushing Protection	Distance	1.45—1.96 mm (0.057—0.077 in.)

23.

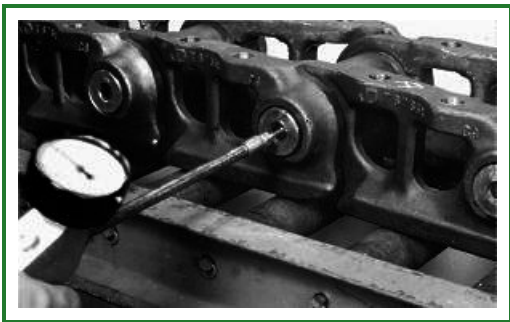

T96287-UN: Oil Application

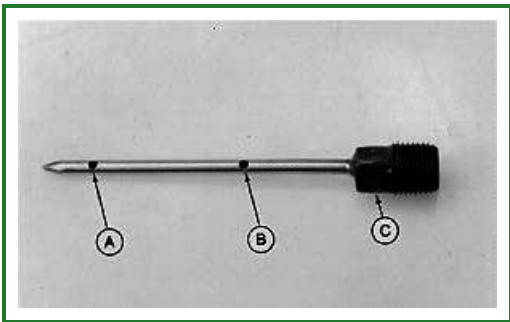

T6465AY-UN: Nozzle and Holes

LEGEND:

- A - Nozzle First Hole
- B - Nozzle Second Hole
- C - Nozzle

Add oil (SAE 80W 90) using a D0890 Seal Tester and Lubricator and A2679 Nozzle (C). Push nozzle through stopper all the way into pin. Depress control lever on the handle enough to draw a vacuum of 68—102 kPa (20—30 in. Hg) as indicated on the gauge.

Item	Measurement	Specification
Lubricated Track		
Gauge Vacuum		68—102 kPa (20—30 in. Hg)

24. Release lever. If there is no decrease in vacuum for a minimum of five seconds, the joints are sealed. If there is a vacuum decrease, seals are not sealing and the joint must be taken apart and repaired.
25. Add oil by depressing the second lever. Oil pressure (read on the same gauge) must be 140—205 kPa (1.4—2.0 bar) (20—30 psi) after both levers are released.

Item	Measurement	Specification
Lubricated Track		
Oil	Pressure	140—205 kPa (1.4—2.0 bar) (20—30 psi)

26. Slowly pull nozzle out to allow any compressed air to escape through nozzle from first hole (A) to second hole (B).
27. Repeat Steps 10—25 for all joints.
28. Install assembled split links on ram plungers, and advance rams to press split links together.
29. Install lubricated track chain. [See Lubricated Track Chain \(Saw Tooth Master Split Link\) Remove and Install](#) . (Group 0130.)
30. Install track shoes. [See Track Shoe Remove and Install](#) . (Group 0130.)

Go to [Section_01:Group_0130](#)

CED,OUTX547,89-19-20131024

Lubricated Track Chain Disassemble and Assemble (Turn Pins and Not Lubricate)**NOTE:**

The following procedure is for disassembly of track chain only to turn pins and bushings. (Chain is not re-lubricated after assembly.)

If this procedure does not apply to repair job, see *Lubricated Track Chain Assembly (Turn Bushings and Lubricate Chain)*. (Group 0130.)

1. Remove track shoes. See *Track Shoe Remove and Install*. (Group 0130.)
2. Use the following track press tool sets:

450J and 550J:

- Tooling Set A2656-213
- Saddle 40989

650J:

- Tooling Set A2656-217
- Saddle 42101 [For stepped bushing design, use 052657-001 saddle.]

3. **IMPORTANT:**

Track press disassembly tools must be in proper alignment with links to prevent broaching of pin and bushing. Damaged links cannot be reused.

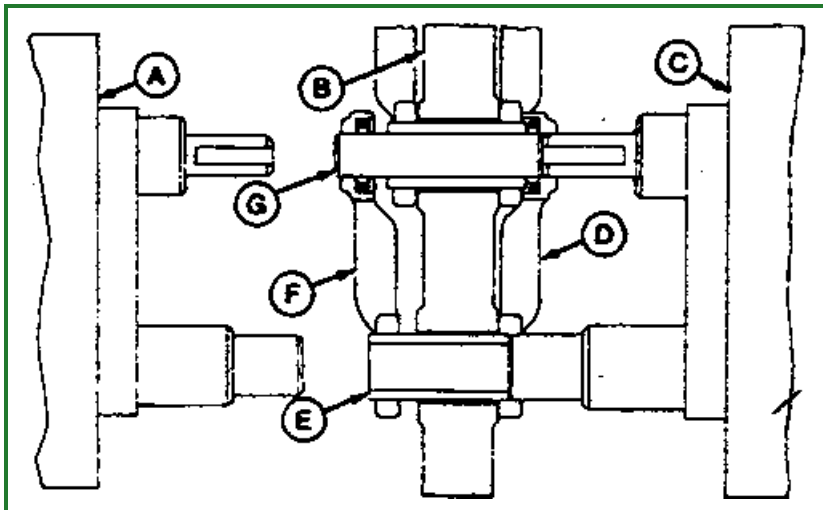
**T96266-UN: Remove Right Pin Bushings****LEGEND:**

- A - Left Ram
- B - Saddle
- C - Right Ram
- D - Right Link
- E - Bushing
- F - Left Link
- G - Pin

Check for proper alignment of tools with pin and bushing.

4. Make an index mark on bushings and pins to aid in assembly, when turning bushings 1/2 turn (180°) to expose a new wear surface.

5.

⚠ CAUTION:

Always wear safety glasses when operating the press. Parts may break or chip, which could create a risk of personal injury.

Extend right ram (C) to push pin (G) and bushing (E) from the right link (D). The right link is forced against the side of saddle (B) as the pin and bushing are pushed out.

6. Track right ram again. The right link, with seals and thrust ring, will stay on the ram tools.

7.

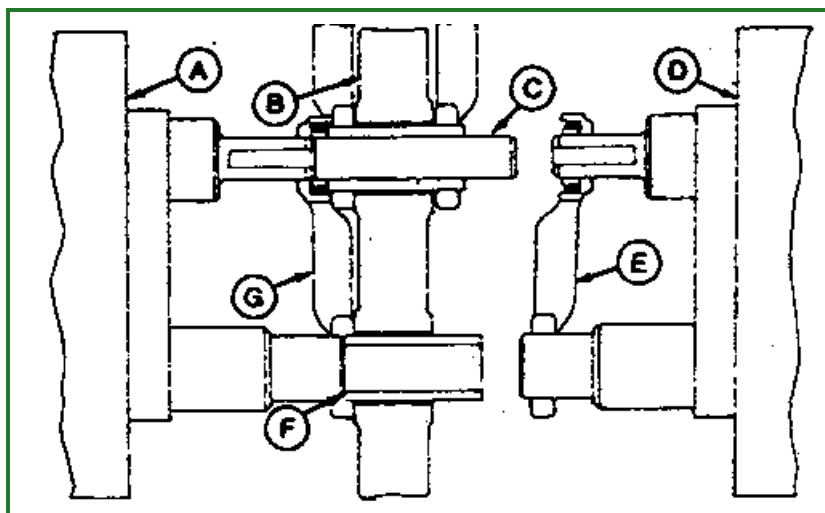

T96267-UN: Remove Left Pin Bushings

LEGEND:

- A - Left Ram
- B - Saddle
- C - Pin
- D - Right Ram
- E - Right Link
- F - Bushing
- G - Left Link

Extend left ram (A) to push the pin (C) and bushing (F) from the left link (G). The left link is forced against the side of saddle (B) as pin and bushing are pushed out.

8. Retract left ram. The left link, with seal and thrust ring, will remain on the ram tools.
9. Remove links and bushing from press.
10. Repeat Steps 4—9 to disassemble rest of chain.
11. All pins, bushings, seals, and thrust rings are used for reassembly, because chain is not re-lubricated. Do not remove stopper and plug from pins. Do not remove seals from track links.

12.

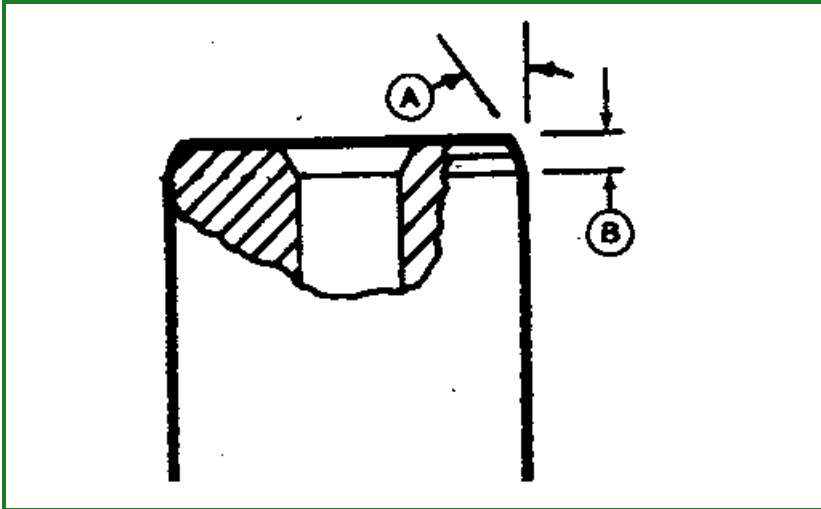

T5798AJ-UN: 3 mm (0.12 in.) x 10° Chamfer

LEGEND:

A - 10°

B - 3 mm (0.12 in.)

Inspect pin ends for wear. If there is no chamfer, grind a new 3 mm (0.12 in.) x 10° chamfer.

Item	Measurement	Specification
Lubricated Track		
Pin	Chamfer	3 mm x 10° (0.12 in.) x 10°

13.



T96289-UN: Track Link Wear

LEGEND:

A - Track Link Wear

Smooth area of track link wear (A) using a grinder, if necessary.

14.

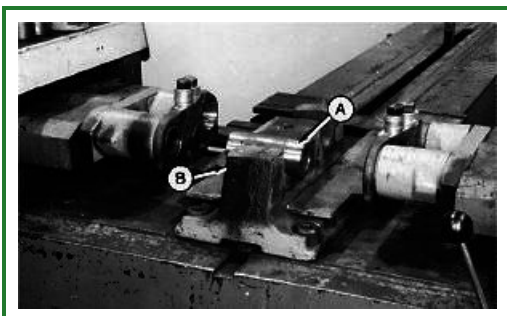

T96273-UN: Bushing and Front Seat of Saddle

LEGEND:

A - Bushing

B - Saddle

Assemble track links using the following track press tool sets:

450J and 550J:

- Tooling Set A2656-213
- Saddle 40989

650J:

- Tooling Set A2656-217
- Saddle 42101 [For stepped bushing design, use 052657-001 saddle.]

15.

NOTE:

Pin end halves of master split link must be temporarily assembled to bushing end halves of link for proper positioning on plungers. Pin end halves will later have to be separated for installation at end of chain. Split links are a matched set and must be assembled as a set.

Assemble master split link halves using master shoe bolts and washers (as required). Tighten bolts just enough to hold link together.

16. Install assembled split links on ram plungers.

17. Install bushing (A) in front seat of saddle (B) so the mark is 180° opposite original location to expose a new wear surface.

18.

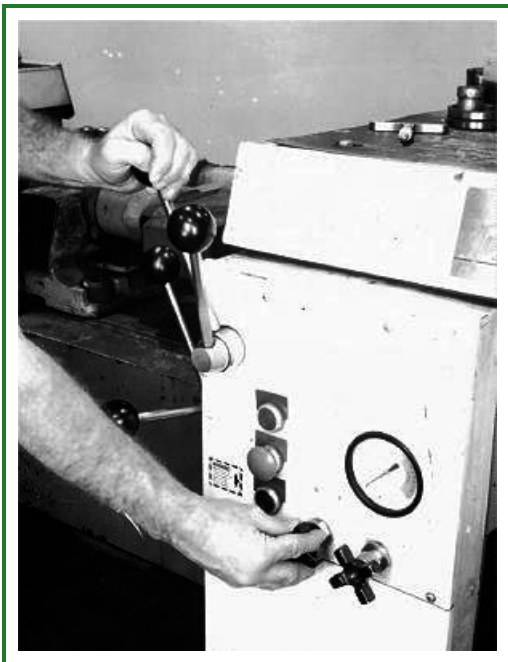

T96274-UN: Relief Valve Adjustment

Adjust track press pressure relief valve setting.

Item	Measurement	Specification
Lubricated Track		
450J and 550J Pressure Relief Valve Setting	Force (Maximum)	284 088 N (63 840 lb force)
650J Pressure Relief Valve Setting	Force (Maximum)	355 110 N (79 800 lb force)

19. IMPORTANT:

Pins must be installed so cross-drilled hole is toward link wear surface or they may break when chain is used.

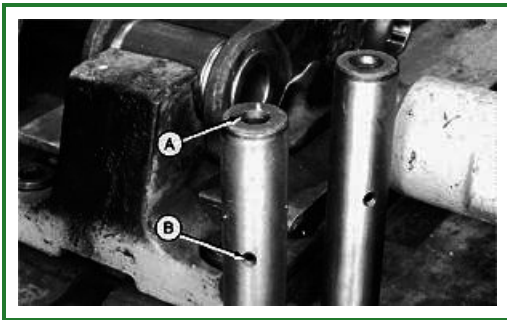

T96277-UN: Cross-Drilled And Pin Hole

LEGEND:

A - Hole in End of Pin

B - Cross-Drilled Hole

Turn pin end-for-end to get a new wear surface, then install it into bushing so cross-drilled hole (B) is toward link wear surface. Install all pins so hole (A) in end of pin is toward the same side of chain, either left or right side.

20.



T96278-UN: Thrust Ring Installation

Install a thrust ring on each end of pin.

21. Move completed link assemble to rear seat of saddle.

22.

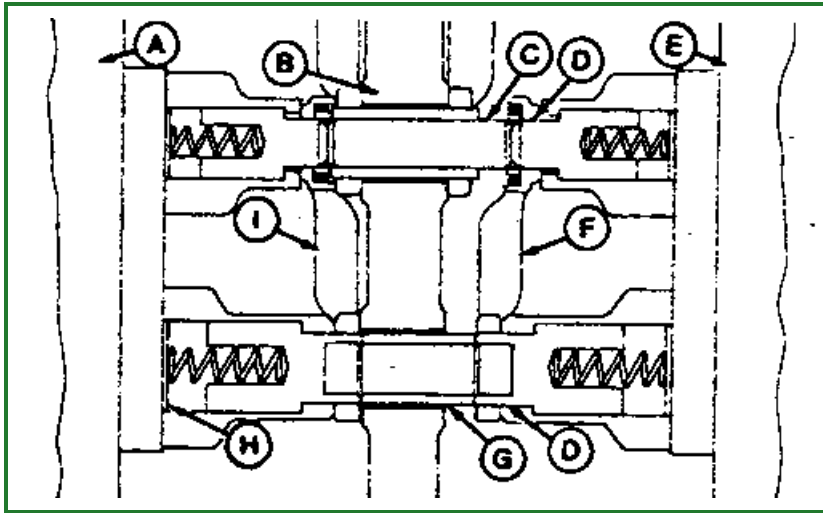
**T96283-UN: Install Link Bushing****LEGEND:**

- A - Left Ram
- B - Saddle
- C - Pin
- D - Plunger
- E - Right Ram
- F - Right Link
- G - Bushing
- H - Plunger Shims
- I - Left Link

Install bushing (G) on front saddle seat. Install left and right links on ram plungers.

23. Advance left ram until left link contacts the saddle. Advance right ram until link is pressed together and bolts can be installed.

24.

**T96286-UN: Overlapping Check**

As chain is being assembled, check to make sure there is some clearance between the overlapping face of links using a feeler gauge. If links contact each other, check bushing projection.

Item	Measurement	Specification
Lubricated Track		
450J and 550J Bushing Protection	Distance	1.63—2.13 mm (0.064—0.084 in.)
650J Bushing Protection	Distance	1.45—1.96 mm (0.057—0.077 in.)

25. Repeat Steps 14—25 to assemble rest of chain.

25. Repeat Steps 14 - 25 to assemble rest of chain.

26. Install assembled split link on ram plungers and advance rams to press split links together.

27. Install assembled split links on ram plungers.

28. Advance ram to press split links together until the joint is tight. Protect split link ends from damage during handling.

29. For procedure to install shoes and tighten cap screws, [see Track Shoe Remove and Install](#) . (Group 0130.).

For procedure to assemble split link and shoe, [see Lubricated Track Chain \(Saw Tooth Master Split Link\) Remove and Install](#) . (Group 0130.)

Go to [Section_01:Group_0130](#)

CED,OUTX547,90-19-20130408

Front Idler Remove and Install

1.

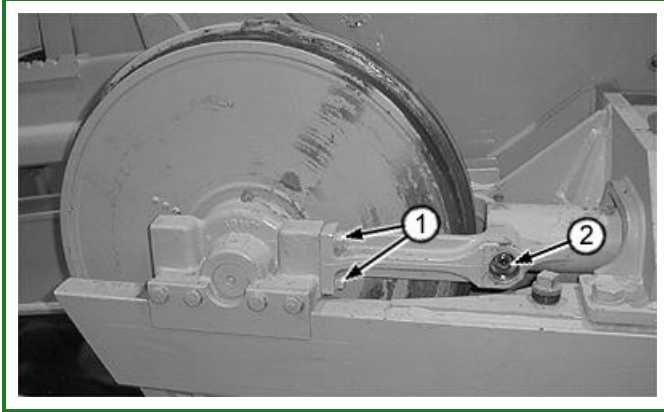

T118526B-UN: Front Idler

LEGEND:

1 - Cap Screw

2 - Check Valve (Not used)

Disconnect track chain.

- See [Sealed Track Chain Removal](#) . (Group 0130.)
- See [Lubricated Track Chain \(Saw Tooth Master Split Link\) Remove and Install](#) . (Group 0130.)

2. Remove cap screws (1) from both sides.

3.

⚠ CAUTION:

The approximate weight of idler is 82 kg (181 lb).

Item	Measurement	Specification
Front Idler		
Front Idler Weight		82 kg Approximate (181 lb) Approximate

Attach hoist and slide front idler forward off track frame.

4. Install idler on track frame. Install and tighten four cap screws and washers (1).

Item	Measurement	Specification
Front Idler		
Adjusting Cylinder Yoke-to-Idler Bracket Cap Screws	Torque	163 N·m (120 lb-ft)

5. Connect track chain.

- See [Sealed Track Chain Installation](#) . (Group 0130.)
- See [Lubricated Track Chain \(Saw Tooth Master Split Link\) Remove and Install](#) . (Group 0130.)

6. Adjust idler. See [Front Idler Adjustment](#) . (Group 0130.)

Go to [Section_01:Group_0130](#)

CED,OUTX547,92-19-20040601

Front Idler Disassemble, Inspect, and Assemble

1.

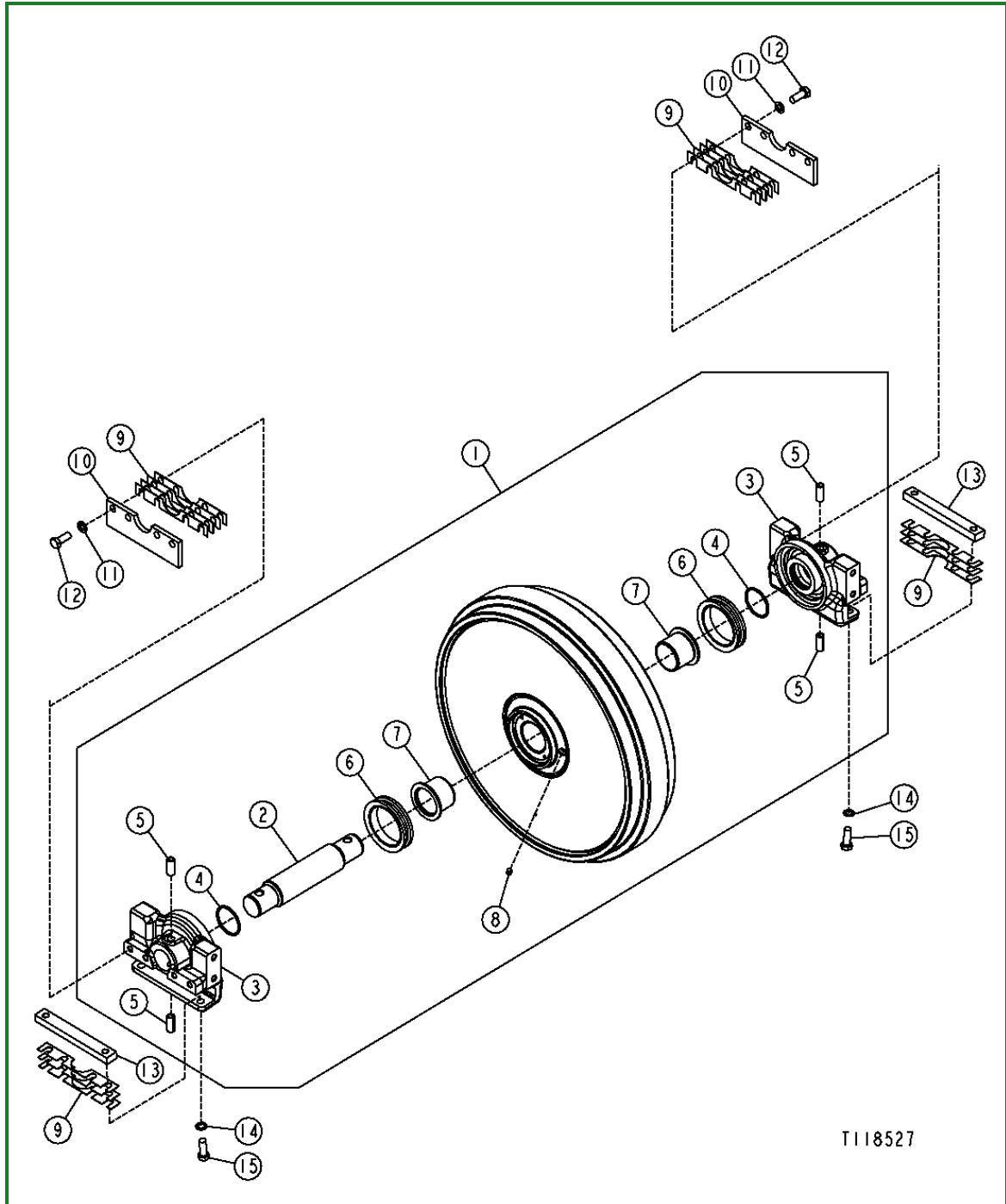

T118527-UN: Front Idler Assembly

LEGEND:

- 1 - Idler Assembly
- 2 - Shaft
- 3 - Bracket (2 used)
- 4 - O-Ring (2 used)
- 5 - Spring Pin (4 used)
- 6 - Metal Face Seal (2 used)
- 7 - Bushing (2 used)
- 8 - Pipe Plug
- 9 - Shim (as required)
- 10 - Guide (2 used)
- 11 - Washer (8 used)

- 12 - Cap Screw (8 used)
- 13 - Wear Plate (2 used)
- 14 - Washer (4 used)
- 15 - Cap Screw (4 used)

Remove cap screws and washers to remove wear strips and shims.

2. Drive pins (5) out.

3. IMPORTANT:

Keep metal face seals (6) lubricated and together at all times while disassembled.

Remove brackets (3), O-rings (4) and metal face seals (6).

4. Remove shaft (2) and inspect bushings (7). Replace if necessary.

5.

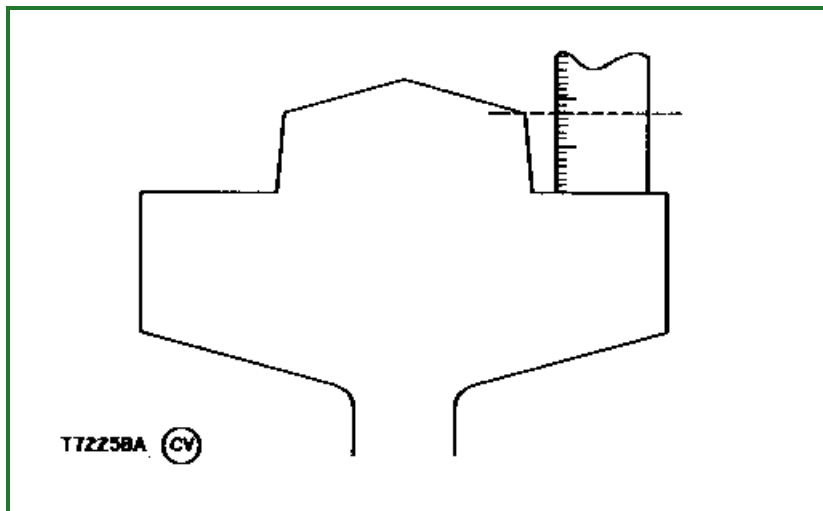

T7225BA-UN: Flange Height Measurement

Measure front idler wear.

- See 450J, 550J, 550K Front Idler Flange Height . (SP326.)
- See 605C, 605K, 650J, 650K Front Idler Flange Height . (SP326.)

NOTE:

100% worn is the maximum allowable height of flange for rebuilding wear surface.

Measure height of flange using a depth gauge such as JT05521 200 mm Ruler, JT05534 Right Angle Attachment, and D05231ST 300 mm Ruler from JT05518 or JT05523 Undercarriage Inspection Service Tool Kit.

6. Install new bushings. Drive in bushings until bottomed.

7. IMPORTANT:

Lubricate idler bushings with oil before installing shaft.

Apply clean hydraulic oil to bushings (7).

8. Inspect metal face seals. [See Metal Face Seals Inspection](#) . (Group 0130.)
9. Install new metal face seals, if necessary.
10. Install shaft (2), O-rings (4), and brackets (3).
11. Drive in spring pins (5).
12. Install guides, wear plates and shims. Adjust idler. [See Front Idler Adjustment](#) . (Group 0130.)
13. Fill idler with oil. [See Front Idler Oil Level Check](#) . (Group 0130.)

Go to [Section_01:Group_0130](#)

CED,OUTX547,93-19-20060123

Front Idler Adjustment

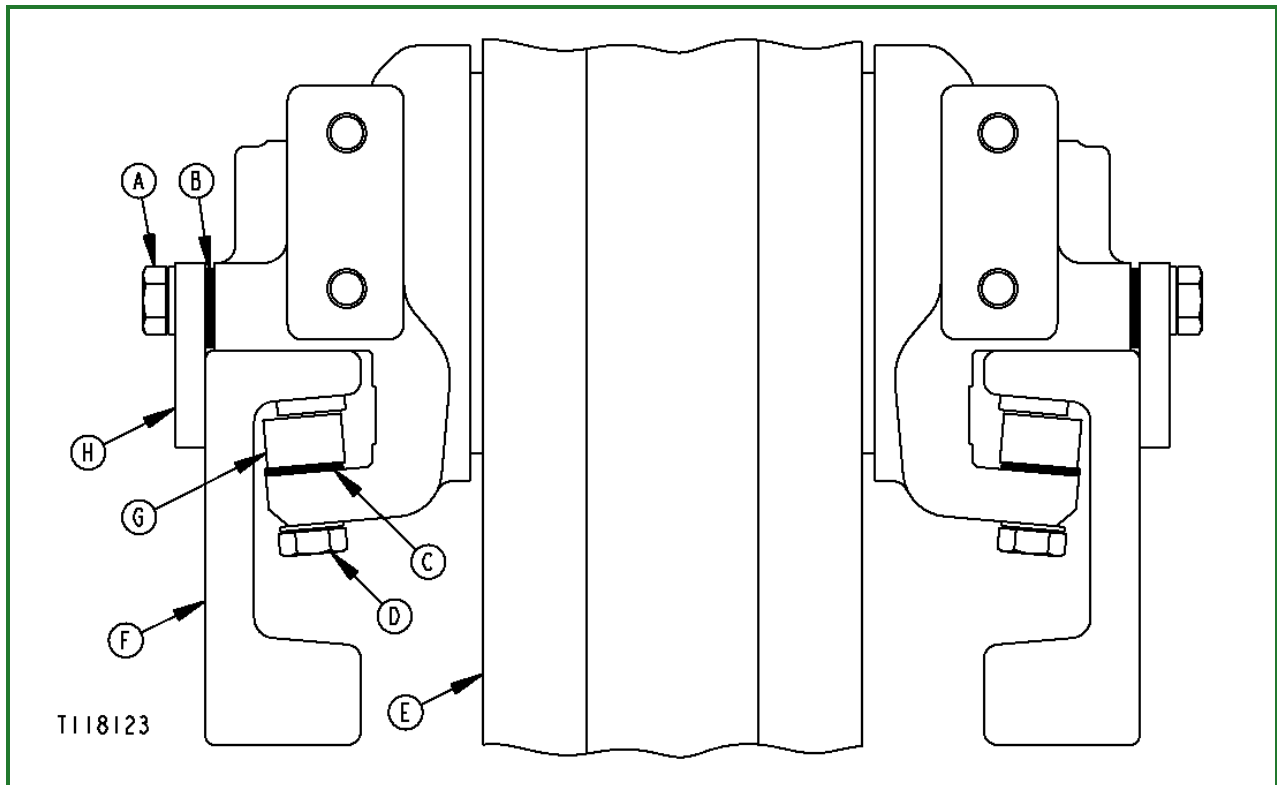

T118123-UN: Front Idler Shim Adjustment

LEGEND:

- A - Cap Screw (8 used)
- B - Shim (as required)
- C - Shim (as required)
- D - Cap Screw (4 used)
- E - Idler
- F - Track Frame
- G - Wear Strip (2 used)
- H - Guide Plate (2 used)

1. **NOTE:**

Idler is to be removed for shimming the bottom wear strips only.

Remove front idler. See [Front Idler Remove and Install](#) . (Group 0130.).

2. Install bottom wear strip (G). Add or remove shims (C) under wear strip to obtain 0.8 mm (0.030 in.) or less clearance.

Item	Measurement	Specification
Front Idler		
Bottom Wear Strip Shimming	Clearance	0.8 mm or less (0.030 in.) or less

3. Tighten cap screws (A).

Item	Measurement	Specification
Front Idler		
Idler Bracket-to-Wear Strip Cap Screws	Torque	163 N·m (120 lb-ft)

4. Install front idler. See [Front Idler Remove and Install](#) . (Group 0130.)
5. Check guide plate (H) clearance. Add or remove shims (B) to obtain 0.8 mm (0.030 in.) clearance.

Item	Measurement	Specification
Front Idler		
Guide Plate Shimming	Clearance	0.8 mm (0.030 in.)

6. Tighten cap screws (D).

Item	Measurement	Specification
Front Idler		
Guide Plate-to-Idler Bracket Cap Screws	Torque	163 N·m (120 lb-ft)

Go to [Section_01:Group_0130](#)

CED,OUTX547,95-19-20040601

Front Idler Oil Level Check

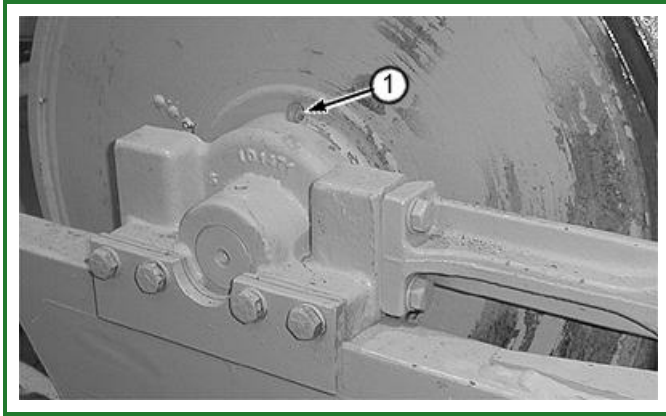

T118598B-UN: Idler Oil Fill Plug

NOTE:

Idlers and rollers are typically sealed for life and the plug in the side is used by the factory to fill the oil cavity initially. Opening this plug to check the oil level introduces the potential to allow contamination entry or leakage from the plug. The plug should only be removed after a seal repair, etc.

Removing the idler oil level plug (1) does not always indicate oil level. Possible vacuum in the oil cavity can keep oil from flowing out. Idlers that appear low or out of oil may have sufficient oil. Applying a small amount of low volume forced air into the idler will overcome the vacuum and allow a small amount of oil to flow from idler.

NOTE:

The oil fill hole should be on outside of idler on the right side of machine. The oil fill hole should be on the inside of idler on the left hand side of the machine.

1. Rotate plug opening (A) to a 45° angle.
2. Remove the oil level fill plug (A).

If oil flows out, oil level is correct.

If oil does not flow, insert the nozzle of a plastic bottle into the hole and squeeze air pressure into idler. A slight amount of pressure inside the idler will relieve any vacuum and allow oil to flow from fill hole.

3. Add proper oil slowly using oil can.
4. Add oil until oil flows from oil level hole.
5. Apply pipe sealant or TEFLON® tape to new plug. Install and tighten oil level plug.

Item	Measurement	Specification
Front Idler		
Oil Level Plug	Torque	41 ± 4 N·m (30 ± 3 lb-ft)

Go to [Section_01:Group_0130](#)

LW86157,000017D-19-20070509

Track Tension Adjuster Remove and Disassemble

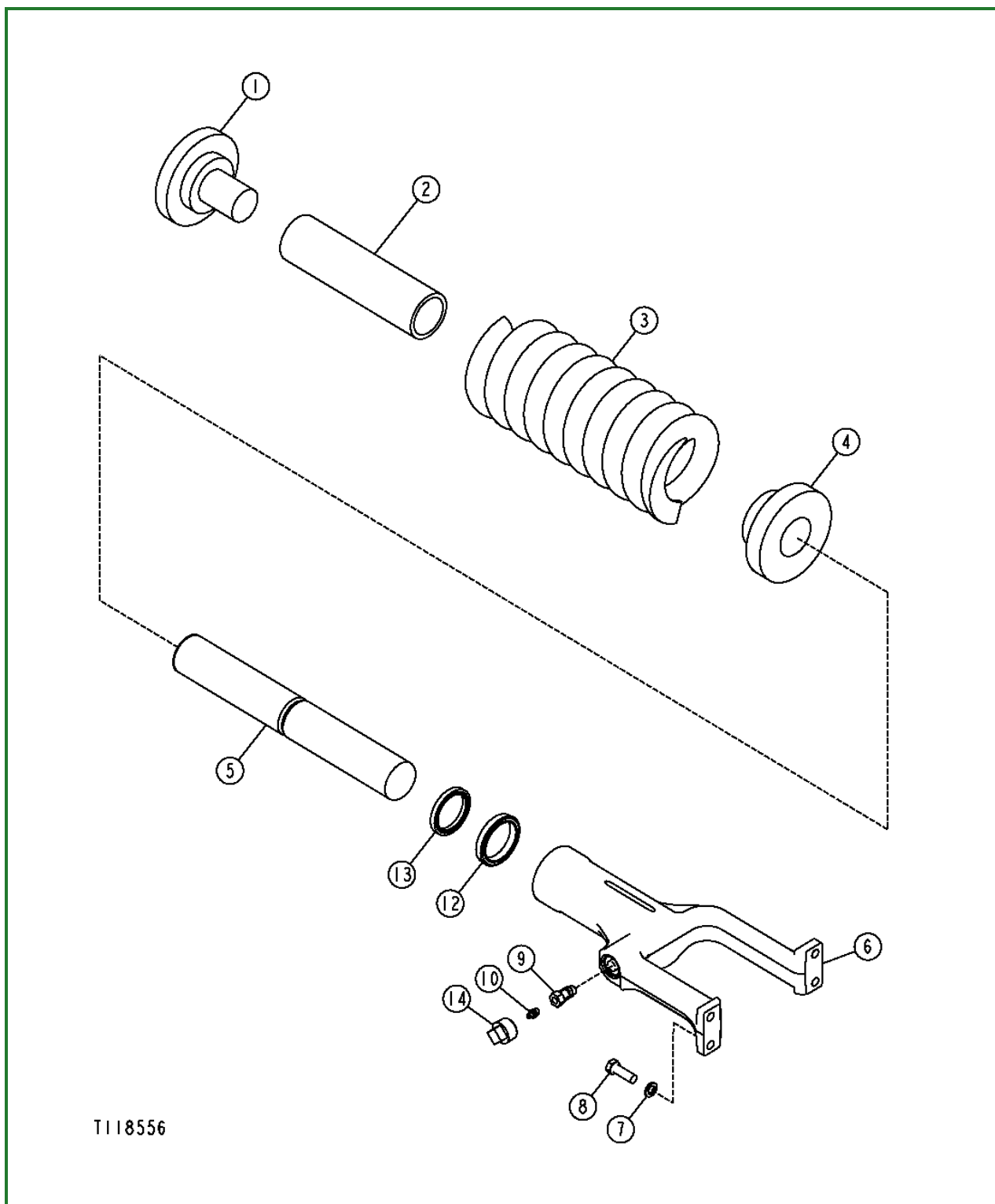

T118556-UN: Track Adjuster

LEGEND:

- 1 - Cap
- 2 - Tube
- 3 - Compression Spring
- 4 - Cap (Front End)
- 5 - Piston
- 6 - Yoke
- 7 - Washer (4 used)
- 8 - Cap Screw (4 used)

- 9 - Check Valve
- 10 - Grease Fitting
- 11 - Not used
- 12 - Seal
- 13 - Seal
- 14 - Plug

⚠ CAUTION:

Grease for track adjuster cylinder is under high pressure. Never remove special grease fitting to release the grease. If grease does not escape immediately from vent hole with relief valve open, slowly drive machine in forward and reverse until grease escapes. DO NOT disassemble parts unless you follow the correct procedure and have correct tools.

If an accident occurs, see a doctor immediately. Any fluid injected into the skin must be surgically removed within a few hours or gangrene may result. Doctors unfamiliar with this type of injury may call the Deere & Company Medical Department in Moline, Illinois, or other knowledgeable medical source.

1. Remove front idler. [See Front Idler Remove and Install](#) . (Group 0130.)
2. Remove adjuster assembly from track frame.
3. IMPORTANT:

Do not pull piston from track adjusting yoke unless seal and piston seal are to be replaced or seals will be damaged.

To aid disassembly, remove grease fitting (10) to prevent suction.
4. Pull track adjusting piston (5) from yoke (6).
5. Remove and discard scraper seal (13) and yoke seal (12).
6. Inspect and clean all parts.

Go to [Section_01:Group_0130](#)

LW86157,000017E-19-20070509

Track Tension Adjuster Assemble and Install



T7247BP-UN: Seal Folded

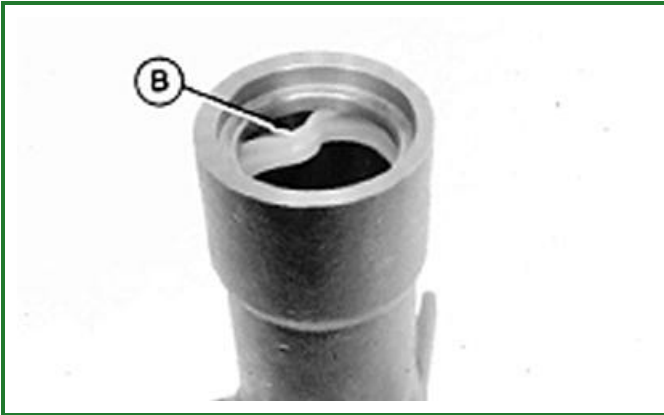

T118646-UN: Track Adjuster Yoke Seal

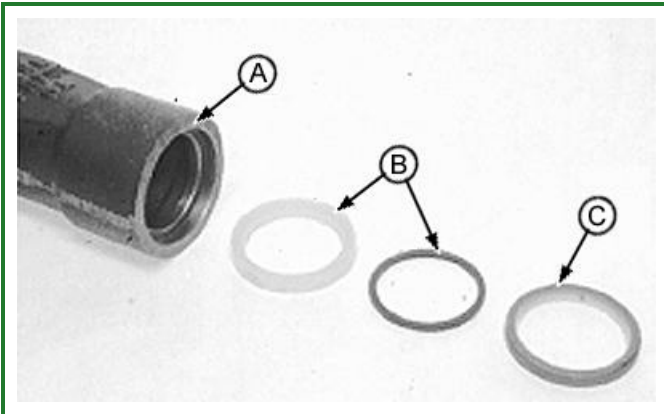

T118647-UN: Track Adjuster Seal and Scraper Seal

LEGEND:

A - Track Adjuster Yoke

B - Seal

C - Scraper Seal

1. Fold seal (B) as shown and install into yoke (A) with seal lip into bore first.
2. Install scraper seal (C) using 57 mm and 73 mm disks.
3. Install piston.

4.

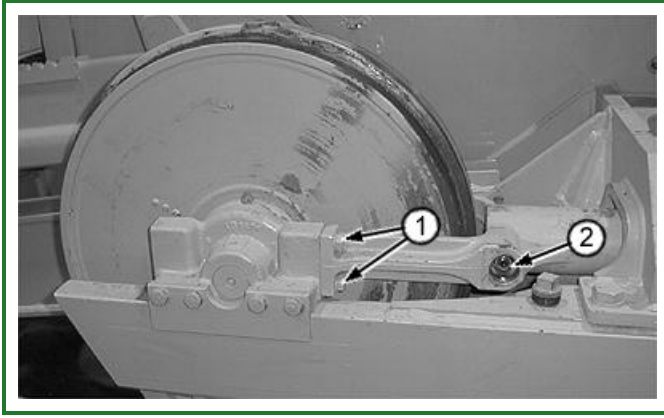
**T118526B-UN: Idler to Yoke Cap Screws****LEGEND:**

1 - Cap Screw (4 used)

2 - Grease Fitting and Plug

Install track adjuster in track frame.

5. Install grease fitting and plug (2).
6. Install idler and tighten cap screws (1).

Item	Measurement	Specification
Hydraulic Track Tension Adjuster		
Adjusting Cylinder Yoke-to-Idler Bracket Cap Screws	Torque	163 N·m (120 lb-ft)

Go to [Section_01:Group_0130](#)

LW86157,0000181-19-20070509

Track Idler Recoil Spring Remove and Install

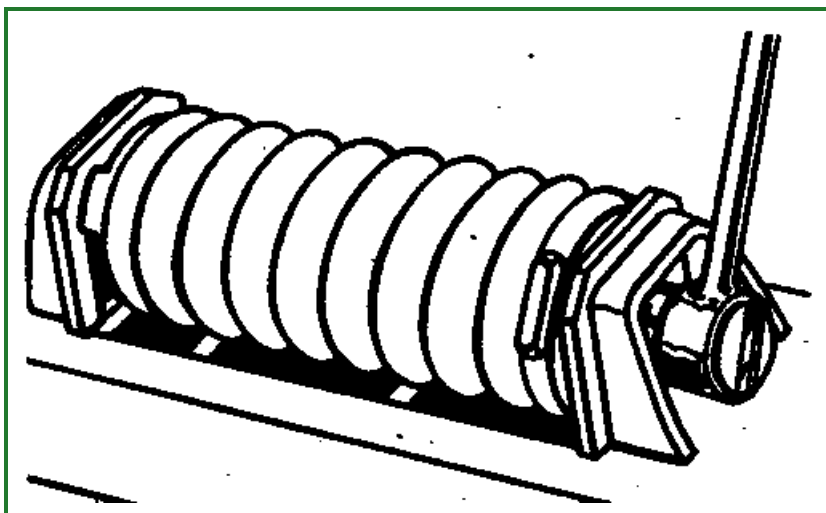

T6555DH-UN: Idler Recoil Spring

IMPORTANT:

When sliding idler assemble forward, do not pull track adjusting piston from yoke as scraper seal may damage piston seal.

1. Slide front idler with hydraulic track tension adjuster assembly forward.
2. Remove cover.
3. Thoroughly clean threads of rear cap.

4.

⚠ CAUTION:

Always use the special bolt to prevent accidental release of idler recoil spring.

Apply John Deere NEVER-SEEZ® Lubricant and insert a T16678 Special Bolt and a 51 mm (2.0 in.) spacer through track spring retainer plate and into rear cap..

Item	Measurement	Specification
Track Recoil Spring		
Spacer Width	51 mm (2.0 in.)	

Tighten bolt until spring compresses to 404 mm (15.9 in.) between outer end of front cap and rear cap.

Item	Measurement	Specification
Track Recoil Spring		
Spring Length	404 mm (15.9 in.)	

5.

⚠ CAUTION:

Spring or rod may break if dropped while handling, transporting or disassembling. Nicks or weld craters in spring and rod assembly can cause

stress concentration resulting in a weak spot that may result in immediate or eventual failure creating a risk of personal injury. Put a heavy protective covering around spring assembly when handling, transporting or disassembling.

A compression tool must be used for disassembly and assembly because of the extreme preload on spring.

Remove spring.

6. Release compression on track spring immediately after removal. See [Track Idler Recoil Spring Disassemble and Assemble](#) . (Group 0130.)
7. Install spring and cover.
8. Slide front idler with hydraulic track tension adjuster back, aligning spring nut with piston.

Go to [Section_01:Group_0130](#)

LW86157,000017F-19-20070509

Track Idler Recoil Spring Disassemble and Assemble

-: Specifications

SPECIFICATIONS	
Track Recoil Spring	
450J and 550J Recoil Spring Approximate Free Length	454 mm 18.0 in
450J and 550J Recoil Spring Test Length at 54 535—64 019 N (12 260—14 392 lbf)	376 mm 14.80 in
650J and 605C Recoil Spring Approximate Free Length	433 mm 17.0 in
650J and 605C Recoil Spring Test Length at 68 058—83 982 N (15 300—18 880 lbf)	376 mm 14.80 in
650J and 605C Recoil Spring	

-: Service Equipment and Tools

SERVICE EQUIPMENT AND TOOLS
DFT1087 [Dealer Fabricated Tool. See Group 9900 for instructions to make tool.] Recoil Spring Guard Tool
ST4920 [Dealer Fabricated Tool. See Group 9900 for instructions to make tool.] Recoil Spring Tool

-: Other Material

OTHER MATERIAL
PT569 U.S. John Deere NEVER-SEEZ® Lubricant

CAUTION:

Spring or rod may break if dropped while handling, transporting or disassembling. Nicks or weld craters in spring and rod assembly can cause stress concentration resulting in a weak spot that may result in immediate or eventual failure creating a risk of personal injury. Put a heavy protective covering around spring assembly when handling, transporting, or disassembling.

A compression tool must be used for disassembly and assembly because of the extreme preload on spring.

1.

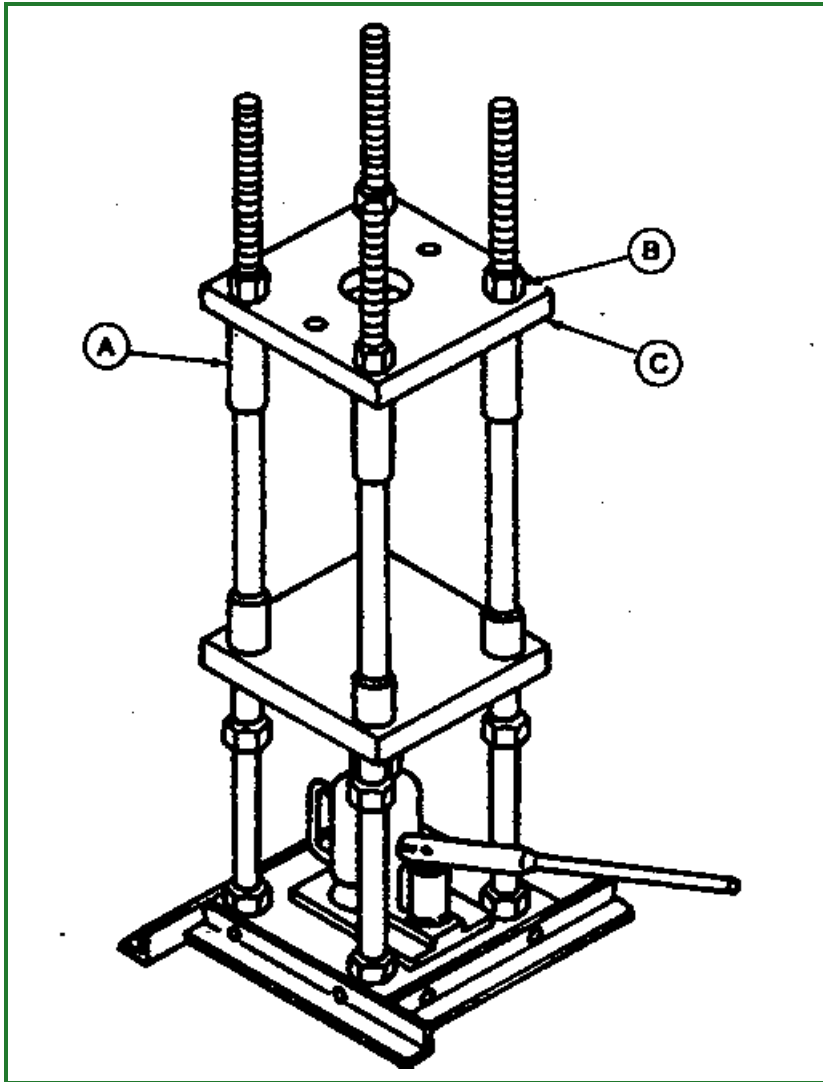

T6557DY-UN: Compression Tool

LEGEND:

A - ST4920 Compression Tool

B - Nuts

C - Top Plate

Put a 10-ton jack on bottom of ST4920 compression tool (A). For instructions on making this tool see [ST4920 Track Recoil Spring Disassembly and Assembly Tool](#) . (Group 9900.)

Remove nuts (B) and top plate (C).

2. Put recoil spring in compression tool.

Item	Measurement	Specification
Track Recoil Spring		
450J and 550J Recoil Spring	Approximate Free Length	454 mm 18.0 in
	Test Length at 54 535—64 019 N (12 260—14 392 lbf)	376 mm 14.80 in
650J and 605C Recoil Spring	Approximate Free Length	433 mm 17.0 in
	Test Length at 68 058—83 982 N (15 300—18 880 lbf)	376 mm 14.80 in

3.

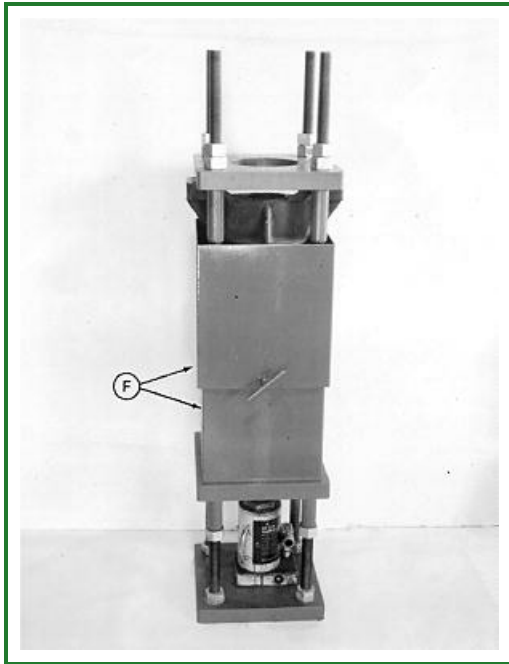

T7126AA-UN: Recoil Spring Guard Tool

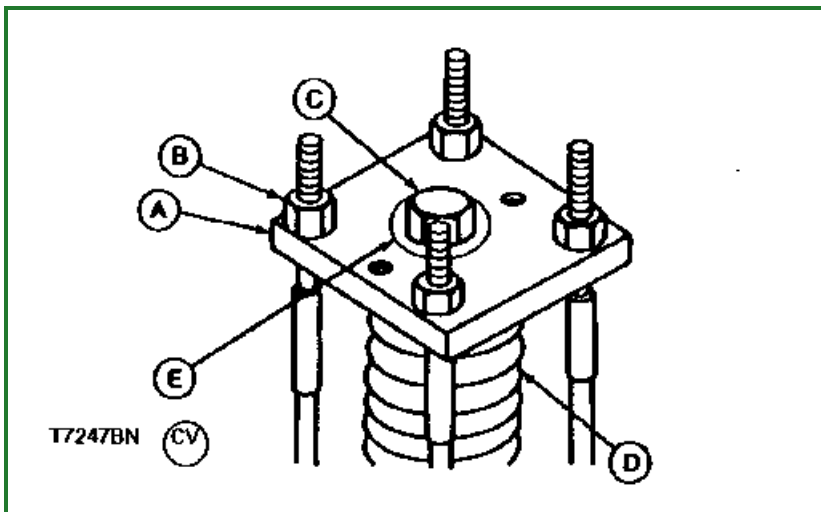

T7247BN-UN: Plate, Spring, Screw Head, and Nuts

LEGEND:

- A - Plate
- B - Nut (4 used)
- C - Cap Screw Head
- D - Recoil Spring
- E - Hole in Plate
- F - DFT1087 Recoil Spring Guard Tool

Install DFT1087 Recoil Spring Guard Tool (F). For instructions on making this tool see [DFT1087 Track Recoil Spring Disassembly and Assembly Guard Tool](#) . (Group 9900.)

4. Install plate (A) and nuts (B) from ST4920 Recoil Spring Tool to secure spring.

5. Be sure cap screw head (C) fits through hole in plate.

6. IMPORTANT:

Cap screw head **MUST** be centered through hole in plate for proper operation of tool.

Compress spring until cap screw (C) fully extends through hole in plate.

7. Remove cap screw (C).
8. Slowly release jack pressure.
9. Remove nuts and plate.
10. Remove spring.

11.

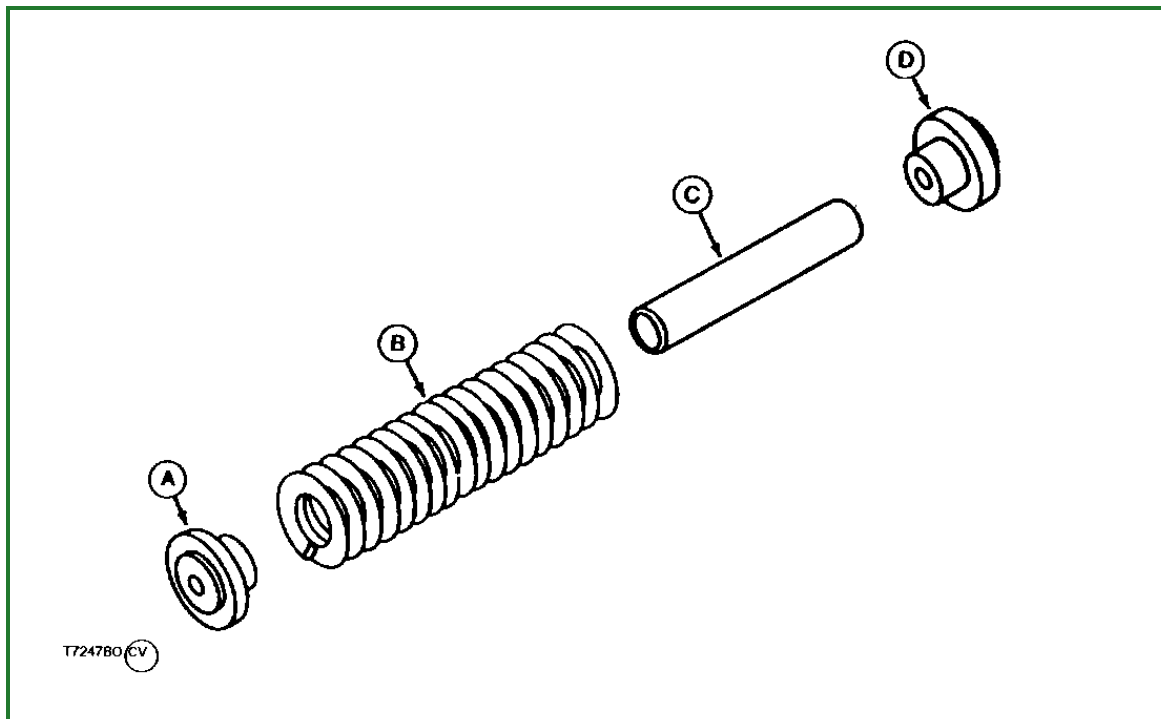

T7247BO-UN: Rear/Front End Caps, Spring, Stop Tube

LEGEND:

- A - Rear End Cap
- B - Spring
- C - Stop Tube
- D - Front End Cap

Remove parts.

12. Check spring for nicks or weld craters. Replace as necessary.
13. Install parts.

14.

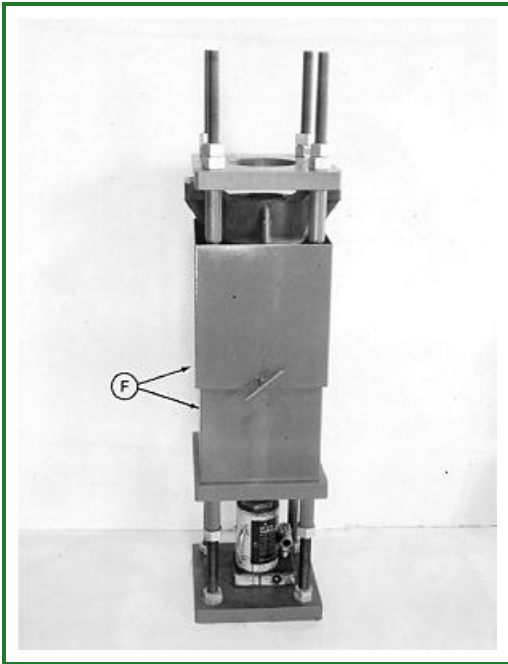

T7126AA-UN: Recoil Spring Guard Tool

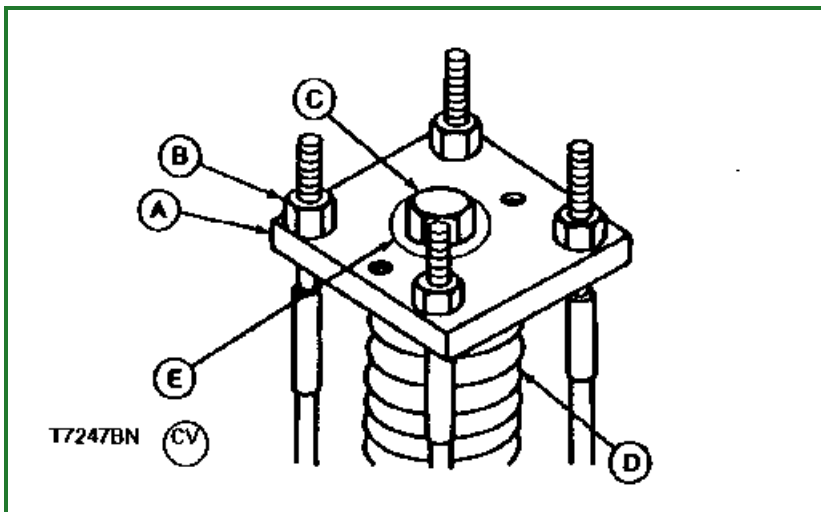

T7247BN-UN: Plate, Spring, Screw Head, and Nuts

LEGEND:

- A - Plate
- B - Nut (4 used)
- C - Cap Screw Head
- D - Recoil Spring
- E - Hole in Plate
- F - DFT1087 Recoil Spring Guard Tool

Install 10-ton jack on bottom of compression tool.

15. Put caps, tube, and recoil spring (D) in compression tool so spring is centered.
16. Install DFT1087 Recoil Spring Guard Tool (F). For instructions on making this tool see [DFT1087 Track Recoil Spring Disassembly and Assembly Guard Tool](#) . (Group 9900.)
17. Install plate (A) and nuts (B) to secure spring.
18. Operate jack to compress spring.
19. Apply John Deere NEVER-SEEZ ® Lubricant to threads of special cap screw (C). Install special cap

screw through hole (E). Be sure cap screw threads fully engage end cap.

20. Slowly release jack and remove nuts and plate.

21. Install spring assembly. [See Track Idler Recoil Spring Remove and Install](#) . (Group 0130.)

Go to [Section_01:Group_0130](#)

LW86157,0000180-19-20170222

Sprocket Remove and Install

NOTE:

Sealed sprocket shown.

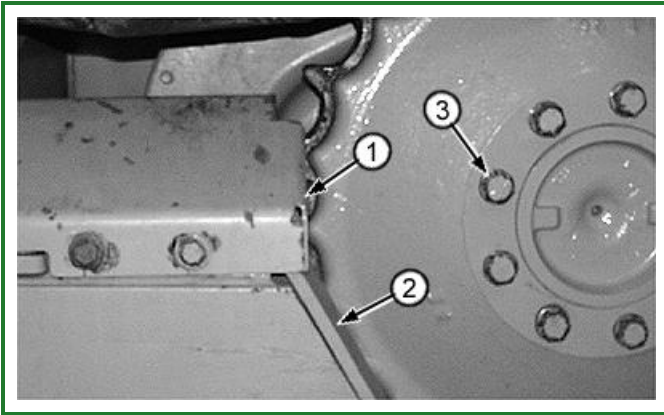

T118653B-UN: Sprocket

LEGEND:

- 1 - Guard
- 2 - Guard
- 3 - Cap Screws

1. Disconnect track chain.

- See [Sealed Track Chain Removal](#) . (Group 0130.)
- See [Lubricated Track Chain \(Saw Tooth Master Split Link\) Remove and Install](#) . (Group 0130.)

2. Raise rear of machine using a 89 000 N (10-ton) floor jack and block securely.

3. Remove guards (1 and 2).

4.

⚠ CAUTION:

Approximate weight of sprocket is 59 kg (130 lb).

Item	Measurement	Specification
Sprocket		
Sprocket Weight		59 kg Approximate (130 lb)

Using a C-clamp and hoist, remove cap screws (3) and lift sprocket from final drive.

5. Sprocket is not repairable. If excessively worn or damaged, replace.

6. Install sprocket. Tighten cap screws.

Item	Measurement	Specification
Sprocket		
Drive Sprocket-to-Axle Shaft Cap Screws	Torque	420 N·m Lubricated (310 lb-ft) Lubricated

7. Install sprocket guards. Tighten cap screws.

Item	Measurement	Specification
Sprocket		
Sprocket Guard Upper Cap Screws	Torque	624 N·m (460 lb-ft)
Sprocket Guard Lower Cap Screws	Torque	203 N·m (150 lb-ft)

8. Install track chain.

- [See Sealed Track Chain Installation . \(Group 0130.\)](#)
- [See Lubricated Track Chain \(Saw Tooth Master Split Link\) Remove and Install . \(Group 0130.\)](#)

Go to [Section_01:Group_0130](#)

CED,OUTX547,101-19-20050930

Track Frame Remove and Install

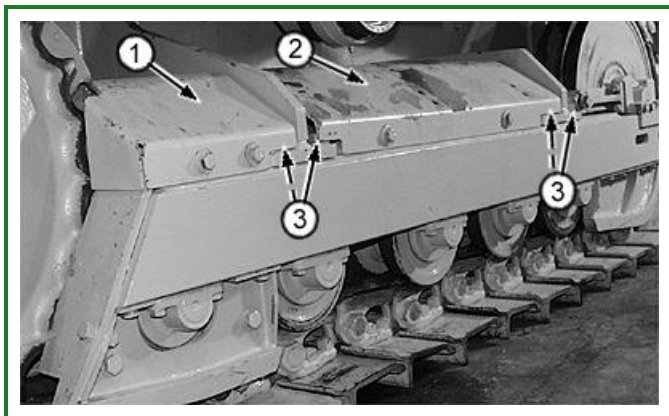

T118665B-UN: Track Frame

LEGEND:

- 1 - Rear Cover
- 2 - Spring Cover
- 3 - Cap Screws (10 used)

1. Remove track.

- See [Sealed Track Chain Removal](#) . (Group 0130.)
- See [Lubricated Track Chain \(Saw Tooth Master Split Link\) Remove and Install](#) . (Group 0130.)

2.

⚠ CAUTION:

Approximate weight of track frame assembly is 862 kg (1900 lb).

Item	Measurement	Specification
Track Frame		
Track Frame Assembly Weight		939 kg Approximate (2070 lb) Approximate

Attach hoist to frame using two chains to balance track frame.

3. Position two 10-ton floor stands to support machine when removing frame.
4. Remove attaching hardware. Pull frame assembly free of crossbars. Inspect and repair. Remove parts as necessary.
5. Install frame and install cap screws (3).
6. Align sprocket with rear track roller. Torque cap screws to specification.

Item	Measurement	Specification
Track Frame		
Frame-to-Track-Frame Cap Screws	Torque	620 N·m (460 lb-ft)

7. Install track.

- See [Sealed Track Chain Installation](#) . (Group 0130.)

- [See Lubricated Track Chain \(Saw Tooth Master Split Link\) Remove and Install . \(Group 0130.\)](#)

[Go to Section_01:Group_0130](#)

CED,OUTX547,102-19-20080827

Track Frame Disassemble and Assemble

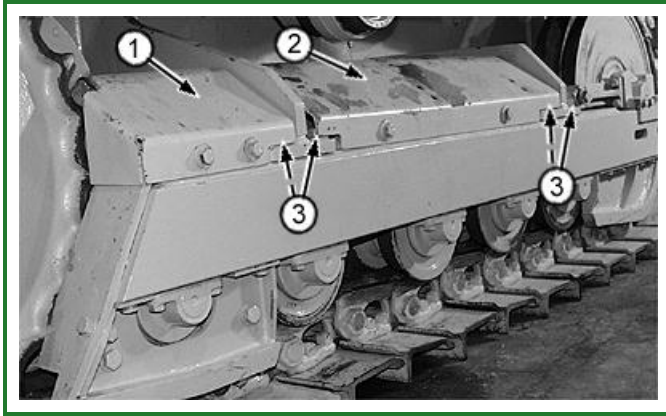

T118665B-UN: Track Frame

LEGEND:

- 1 - Rear Cover
- 2 - Spring Cover
- 3 - Cap Screws (10 used)

1. Remove track.

- See [Sealed Track Chain Removal](#) . (Group 0130.)
- See [Lubricated Track Chain \(Saw Tooth Master Split Link\) Remove and Install](#) . (Group 0130.)

2. Remove track frame. See [Track Frame Remove and Install](#) . (Group 0130.)

3.

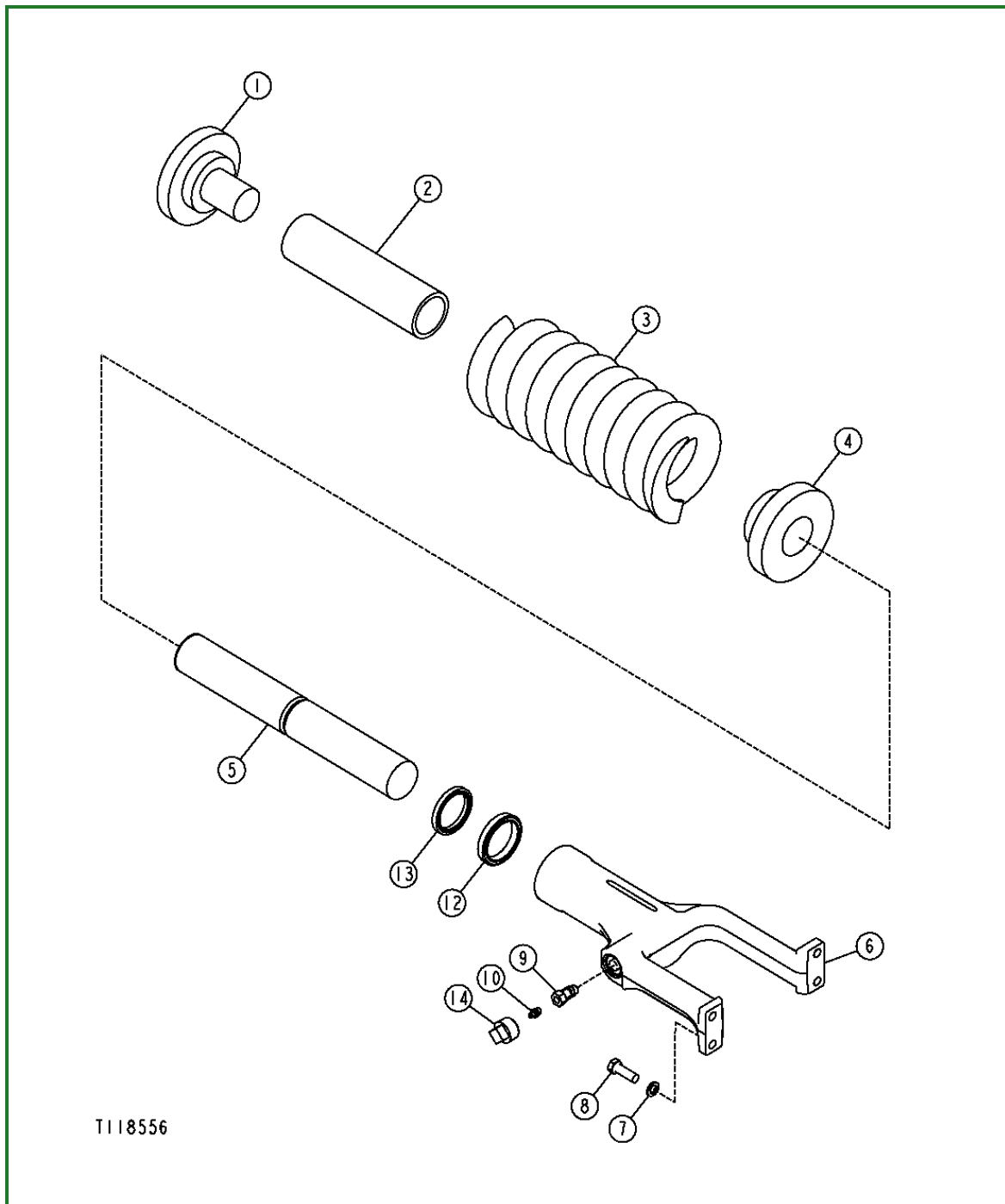
**T118556-UN: Track Tension Adjuster****LEGEND:**

- 1 - Cap
- 2 - Tube
- 3 - Compression Spring
- 4 - Cap (Front End)
- 5 - Piston
- 6 - Yoke
- 7 - Washer (4 used)
- 8 - Cap Screw (4 used)
- 9 - Check Valve
- 10 - Grease Fitting
- 11 - Not used
- 12 - Seal
- 13 - Seal

14 - Plug

Remove track tension adjuster. [See Track Tension Adjuster Remove and Disassemble](#) . (Group 0130.)

4. Remove track idler recoil spring. [See Track Idler Recoil Spring Remove and Install](#) . (Group 0130.)
5. If necessary, disassemble track idler recoil spring. [See Track Idler Recoil Spring Disassemble and Assemble](#) . (Group 0130.)
6. Repair or replace parts as necessary.
7. If necessary, assemble track idler recoil spring. [See Track Idler Recoil Spring Disassemble and Assemble](#) . (Group 0130.)
8. Install track tension adjuster.
 1. Inspect and clean all parts.
 2. Install track idler recoil spring. [See Track Idler Recoil Spring Remove and Install](#) . (Group 0130.)
 3. Install new scraper seal (13) and yoke seal (12).
 4. Install track adjusting piston (5) in yoke (6).
 5. If removed, install grease fitting (10).
 6. Install adjuster assembly into track frame.
9. Install track frame. [See Track Frame Remove and Install](#) . (Group 0130.)
10. Install track.
 - [See Sealed Track Chain Installation](#) . (Group 0130.)
 - [See Lubricated Track Chain \(Saw Tooth Master Split Link\) Remove and Install](#) . (Group 0130.)

Go to [Section_01:Group_0130](#)

LW86157,000011C-19-20070605

Frame Wear Strips Remove and Install

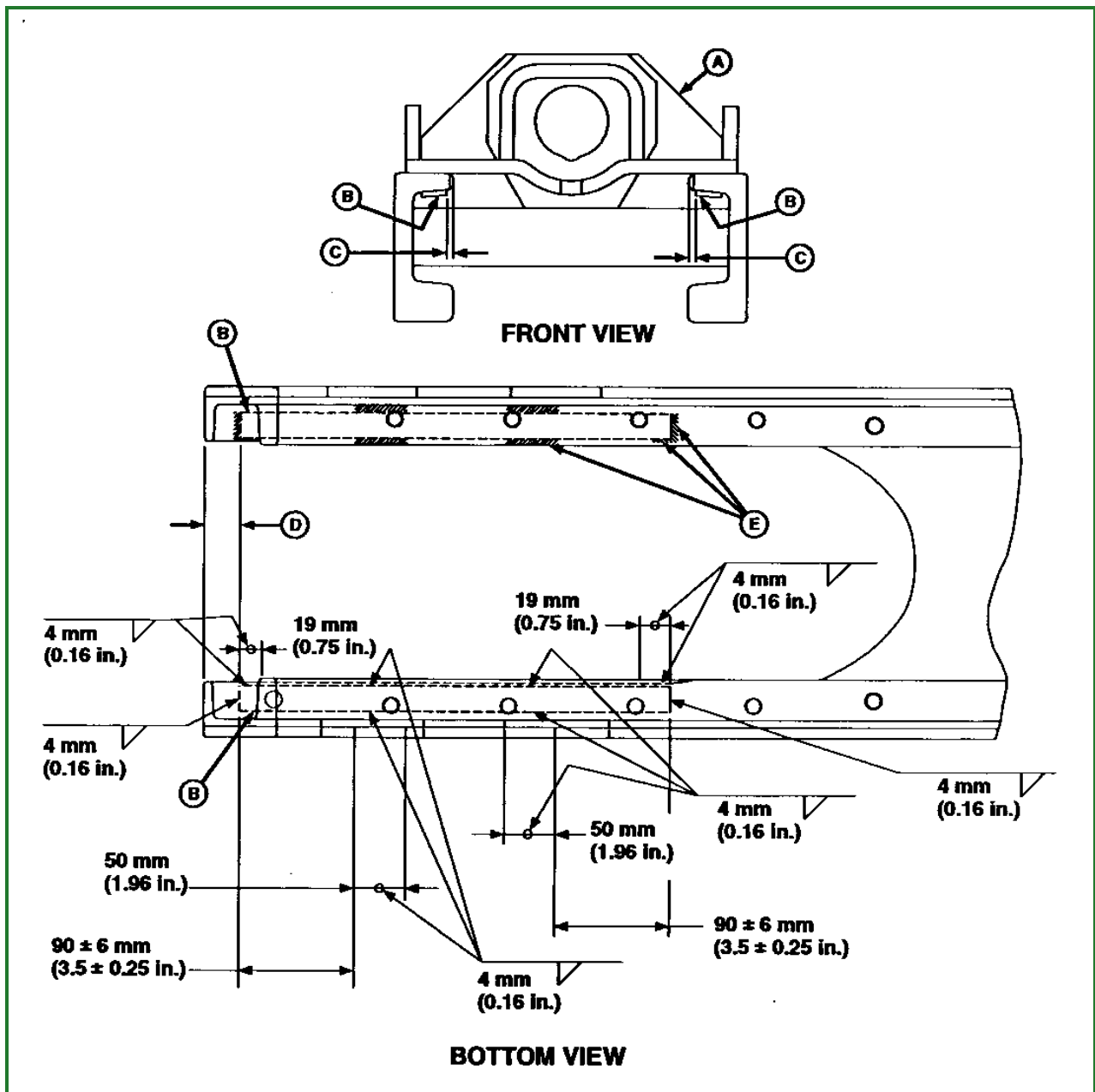

T8058AH-UN: Front/Bottom View of Wear Strips

LEGEND:

- A - Track Frame
- B - Wear Strip (2 used)
- C - 6 ± 1.5 mm (0.23 ± 0.06 in.)
- D - 30.8 mm (1.21 in.)
- E - Welded Areas

1. Remove front idler. See [Front Idler Remove and Install](#) . (Group 0130.)
2. Remove wear strips (B).
3. Grind track frame (A) wear strip surfaces smooth. Area must be free of any weld spatter.
4. IMPORTANT:

Good welds are important. Have only a qualified welder do the procedure. Use E7018 electrodes.

Before welding, clean all dirt and paint from the weld areas and turn battery disconnect switch to OFF.

Connect the welder ground clamp close to each weld area so electrical current does not pass through any bearings.

If track frame is still on machine, make sure the battery disconnect switch is turned to the OFF position.

5. Clamp wear strip in position, using dimensions (C and D).
6. Weld each wear strip in eight places as indicated using E7018 electrodes.
7. Install and adjust front idler. [See Front Idler Remove and Install](#) . [See Front Idler Adjustment](#) . (Group 0130.)

Go to [Section_01:Group_0130](#)

CED,OUTX547,103-19-20040601

Section 02: Axles and Suspension Systems

Group 0201: Drive Axle Housing and Support

Final Drive Remove and Install

Group 0250: Axle Shaft, Bearings, and Reduction Gear

Final Drive Disassemble and Assemble

Final Drive Remove and Install

-: Specifications

SPECIFICATIONS	
Sprocket Weight	59 kg Approximate 130 lb Approximate
Final Drive Weight	340 kg Approximate 750 lb Approximate

-: Service Equipment and Tools

SERVICE EQUIPMENT AND TOOLS
DFT1063 [Dealer Fabricated Tool. See Group 0999 for instructions to make tool.] Final Drive Lifting Bracket
DFT1166 [Dealer Fabricated Tool. See Group 0999 for instructions to make tool.] Final Drive Lifting Bracket Adapter
DFT1167 [Dealer Fabricated Tool. See Group 0999 for instructions to make tool.] Final Drive Lifting Bracket Adapter Spacer

-: Other Material

OTHER MATERIAL
277 Loctite® Thread Lock and Sealer (high strength)

1. Disconnect track chain. See [Lubricated Track Chain \(Saw Tooth Master Split Link\) Remove and Install](#) . (Group 0130.)
2. Remove hydrostatic motor. See [Hydrostatic Motor Remove and Install](#) . (Group 0300.)
3. Raise rear of machine using a 89 000 N (10-ton) floor jack and block securely.

4.

CAUTION:

The approximate weight of sprocket is 59 kg (130 lb).

Item	Measurement	Specification
Final Drive		
Sprocket Weight		59 kg Approximate 130 lb Approximate

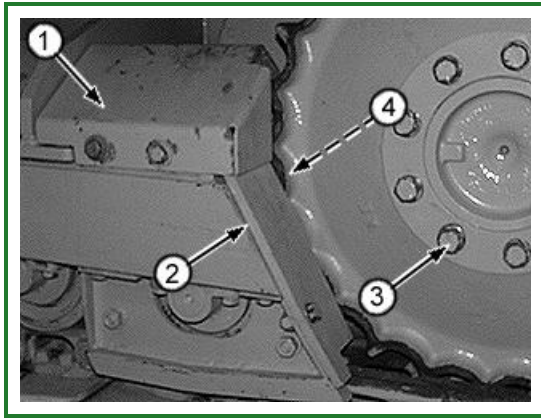

T118793B-UN: 450J Shown

LEGEND:

- 1 - Cover
- 2 - Outer Guard
- 3 - Cap Screws
- 4 - Inner Guard

Remove cover (1), outer guard (2) and inner guard (4). Attach a C-clamp and a hoist to sprocket. Remove cap screws (3) and sprocket.

5.

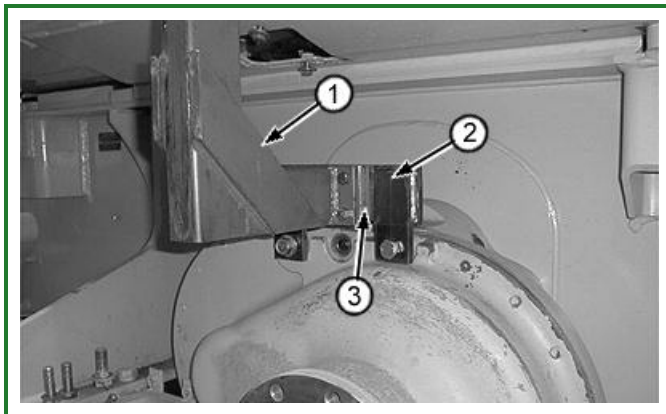

T118794B-UN: 450J Shown

LEGEND:

- 1 - Final Drive Lifting Bracket
- 2 - Lifting Bracket Adapter
- 3 - Lifting Bracket Adapter Spacer (450J only)

Install DFT1063 Final Drive Lift Bracket (1), DFT1166 Final Drive Lifting Bracket Adapter (2), and for 450J machines DFT1167 Final Drive Lifting Bracket Adapter Spacer (3) on final drive.

[See DFT1063 Final Drive Lift Bracket](#) . (Group 9900.)

[See DFT1166 Final Drive Lifting Bracket Adapter](#) . (Group 9900.)

[See DFT1167 Final Drive Lifting Bracket Adapter Spacer](#) . (Group 9900.)

6.

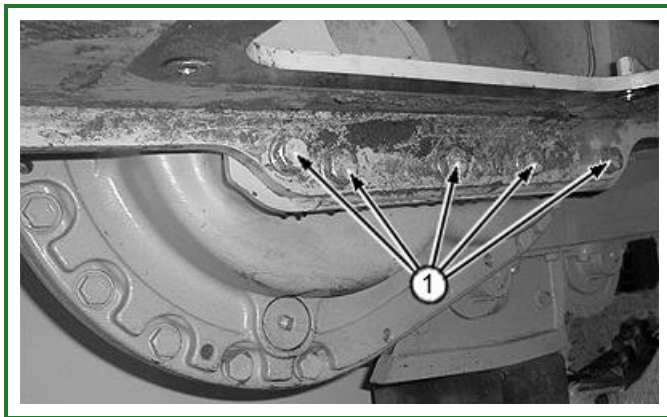

T118795B-UN: Frame to Final Drive Cap Screws

LEGEND:

1 - Cap Screw (5 used)

Remove cap screws (1).

7.

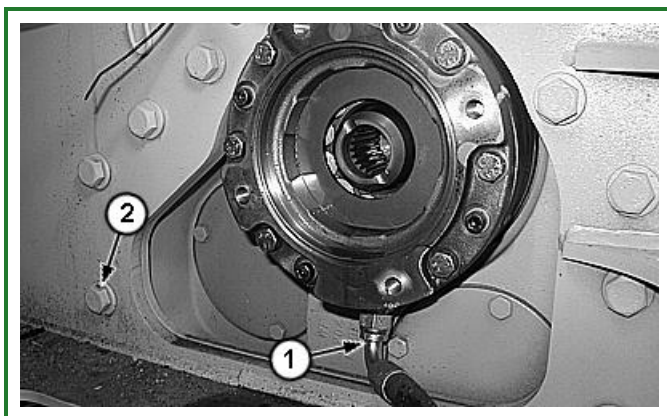

T199300A-UN: Final Drive

LEGEND:

1 - Park Brake Hose

2 - Cap Screw (11 used)

Disconnect park brake hose (1).

8.

⚠ CAUTION:

The approximate weight of final drive is 340 kg (750 lb).

Item	Measurement	Specification
Final Drive		
Final Drive Weight		340 kg Approximate 750 lb Approximate

Remove 11 cap screws (2). Remove final drive assembly.

9.

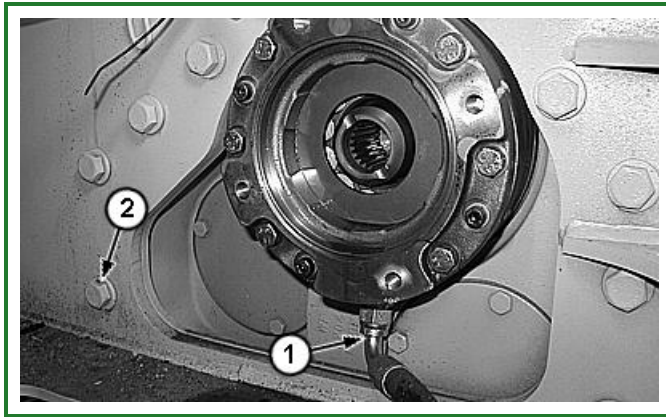

T199300A-UN: Final Drive

LEGEND:

- 1 - Park Brake Hose
- 2 - Cap Screw (11 used)

Clean all mating surfaces of final drive.

- 10. Apply PM38656 Thread Lock and Sealer (high strength) to surface of final drive and attaching hardware.
- 11. Install final drive assembly.
- 12. Connect park brake hose (1).
- 13. Install cap screws (2).

14.

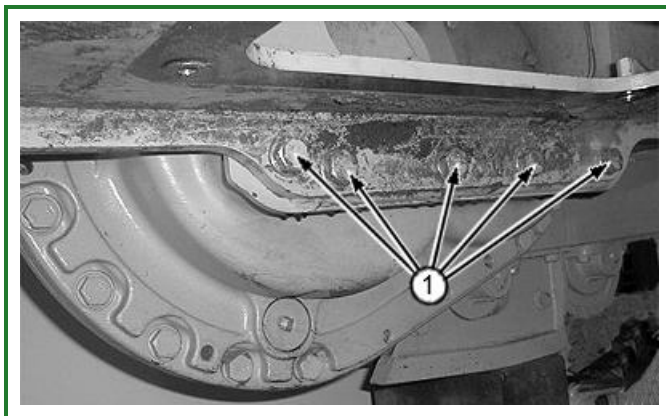

T118795B-UN: Frame to Final Drive Cap Screws

LEGEND:

- 1 - Cap Screw (5 used)

Install cap screws (1).

15.

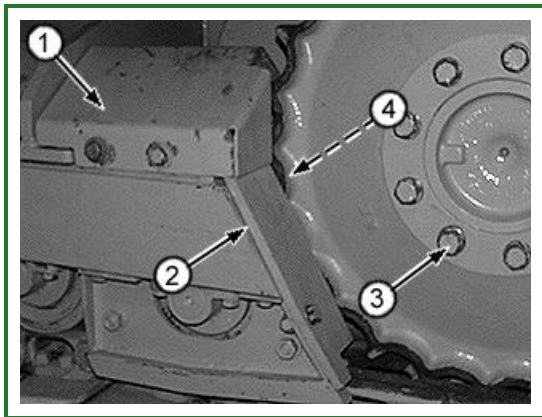
**T118793B-UN: 450J Shown****LEGEND:**

- 1 - Cover
- 2 - Outer Guard
- 3 - Cap Screws (9 used)
- 4 - Inner Guard

Install inner guard (4), sprocket and cap screws (3), outer guard (2) and cover (1).

16. Install hydrostatic motor. [See Hydrostatic Motor Remove and Install](#) .(Group 0300.)

17. Connect track chain. [See Lubricated Track Chain \(Saw Tooth Master Split Link\) Remove and Install](#) .
(Group 0130.)

Go to [Section_02:Group_0201](#)

TE14778,0000023-19-20131024

Final Drive Remove and Install

-: Specifications

SPECIFICATIONS	
Sprocket Weight	59 kg Approximate 130 lb Approximate
Final Drive Weight	340 kg Approximate 750 lb Approximate

-: Service Equipment and Tools

SERVICE EQUIPMENT AND TOOLS
DFT1063 [Dealer Fabricated Tool. See Group 0999 for instructions to make tool.] Final Drive Lifting Bracket
DFT1166 [Dealer Fabricated Tool. See Group 0999 for instructions to make tool.] Final Drive Lifting Bracket Adapter
DFT1167 [Dealer Fabricated Tool. See Group 0999 for instructions to make tool.] Final Drive Lifting Bracket Adapter Spacer

-: Other Material

OTHER MATERIAL
277 Loctite® Thread Lock and Sealer (high strength)

1. Disconnect track chain. See [Lubricated Track Chain \(Saw Tooth Master Split Link\) Remove and Install](#) . (Group 0130.)
2. Remove hydrostatic motor. See [Hydrostatic Motor Remove and Install](#) . (Group 0300.)
3. Raise rear of machine using a 89 000 N (10-ton) floor jack and block securely.

4.

CAUTION:

The approximate weight of sprocket is 59 kg (130 lb).

Item	Measurement	Specification
Final Drive		
Sprocket Weight		59 kg Approximate 130 lb Approximate

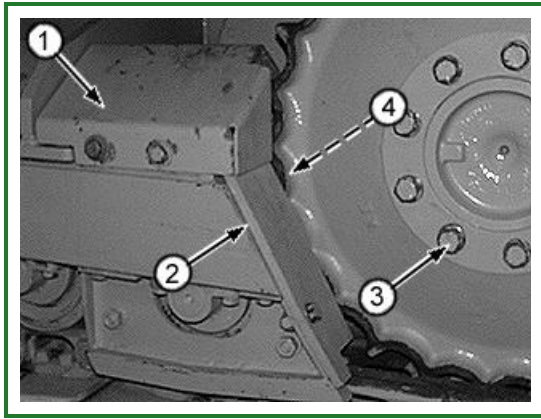

T118793B-UN: 450J Shown

LEGEND:

- 1 - Cover
- 2 - Outer Guard
- 3 - Cap Screws
- 4 - Inner Guard

Remove cover (1), outer guard (2) and inner guard (4). Attach a C-clamp and a hoist to sprocket. Remove cap screws (3) and sprocket.

5.

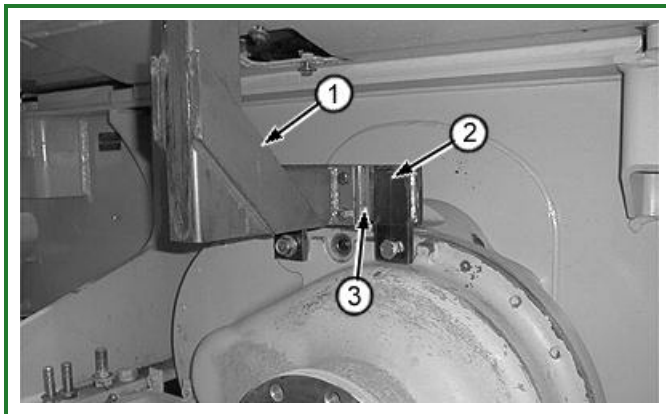

T118794B-UN: 450J Shown

LEGEND:

- 1 - Final Drive Lifting Bracket
- 2 - Lifting Bracket Adapter
- 3 - Lifting Bracket Adapter Spacer (450J only)

Install DFT1063 Final Drive Lift Bracket (1), DFT1166 Final Drive Lifting Bracket Adapter (2), and for 450J machines DFT1167 Final Drive Lifting Bracket Adapter Spacer (3) on final drive.

[See DFT1063 Final Drive Lift Bracket](#) . (Group 9900.)

[See DFT1166 Final Drive Lifting Bracket Adapter](#) . (Group 9900.)

[See DFT1167 Final Drive Lifting Bracket Adapter Spacer](#) . (Group 9900.)

6.

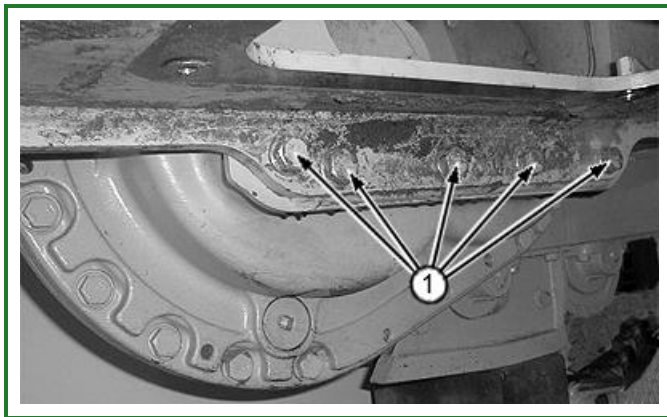

T118795B-UN: Frame to Final Drive Cap Screws

LEGEND:

1 - Cap Screw (5 used)

Remove cap screws (1).

7.

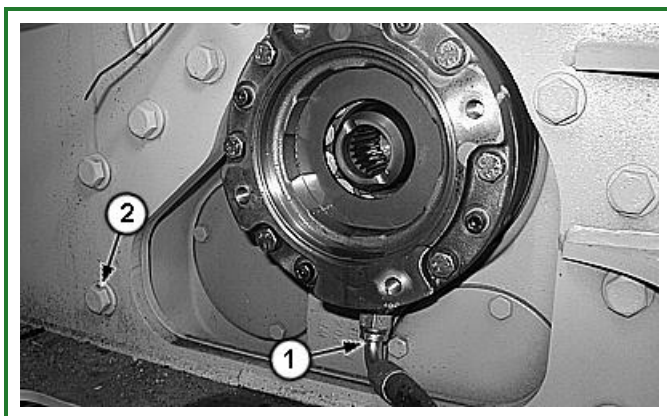

T199300A-UN: Final Drive

LEGEND:

1 - Park Brake Hose

2 - Cap Screw (11 used)

Disconnect park brake hose (1).

8.

⚠ CAUTION:

The approximate weight of final drive is 340 kg (750 lb).

Item	Measurement	Specification
Final Drive		
Final Drive Weight		340 kg Approximate 750 lb Approximate

Remove 11 cap screws (2). Remove final drive assembly.

9.

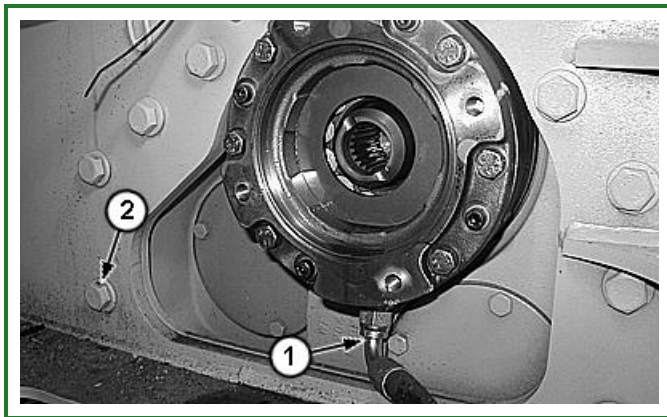

T199300A-UN: Final Drive

LEGEND:

- 1 - Park Brake Hose
- 2 - Cap Screw (11 used)

Clean all mating surfaces of final drive.

- 10. Apply PM38656 Thread Lock and Sealer (high strength) to surface of final drive and attaching hardware.
- 11. Install final drive assembly.
- 12. Connect park brake hose (1).
- 13. Install cap screws (2).

14.

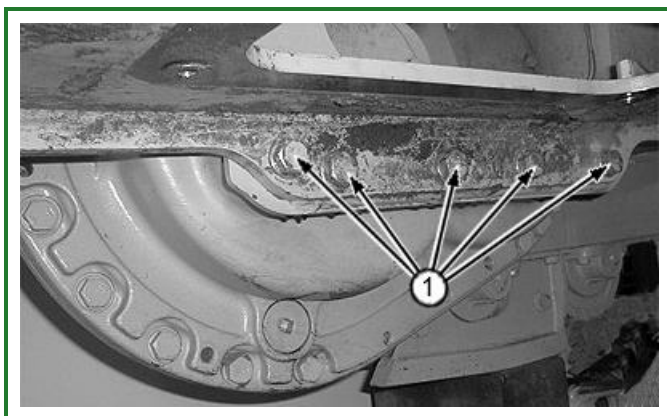

T118795B-UN: Frame to Final Drive Cap Screws

LEGEND:

- 1 - Cap Screw (5 used)

Install cap screws (1).

15.

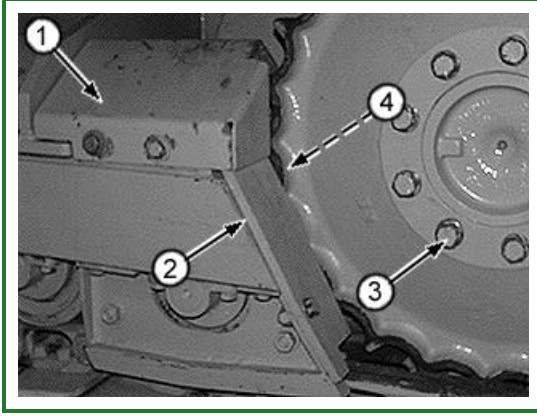
**T118793B-UN: 450J Shown****LEGEND:**

- 1 - Cover
- 2 - Outer Guard
- 3 - Cap Screws (9 used)
- 4 - Inner Guard

Install inner guard (4), sprocket and cap screws (3), outer guard (2) and cover (1).

16. Install hydrostatic motor. [See Hydrostatic Motor Remove and Install](#) .(Group 0300.)

17. Connect track chain. [See Lubricated Track Chain \(Saw Tooth Master Split Link\) Remove and Install](#) .
(Group 0130.)

Go to [Section_02:Group_0201](#)

TE14778,0000023-19-20131024

Final Drive Disassemble and Assemble

NOTE:

450J shown unless otherwise indicated.

1.

NOTE:

The approximate capacity of each final drive is 8.5 L (9 qt).

Drain oil from final drive.

2.

⚠ CAUTION:

Final drive assembly weighs approximately 340 kg (750 lbs). Use proper lifting equipment and safety precautions. Failure to do so may cause personal injury.

Block and support final drive on heavy-duty bench.

Item	Measurement	Specification
Final Drive Assembly	Weight	340 kg Approximate 750 lb Approximate

3.

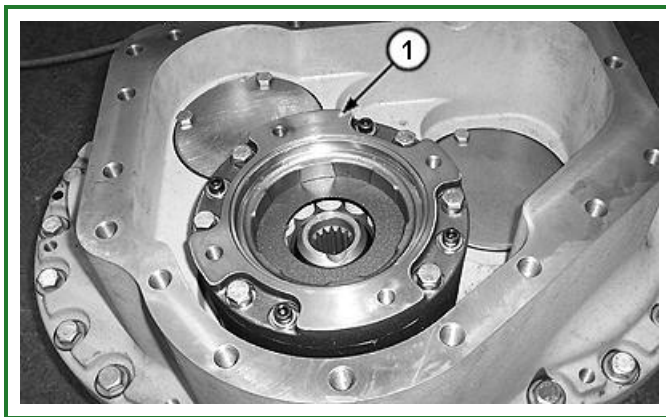

T199297A-UN: Park Brake Assembly

Remove park brake assembly. See [Park Brake Remove and Install](#) . (Group 1100.)

4.

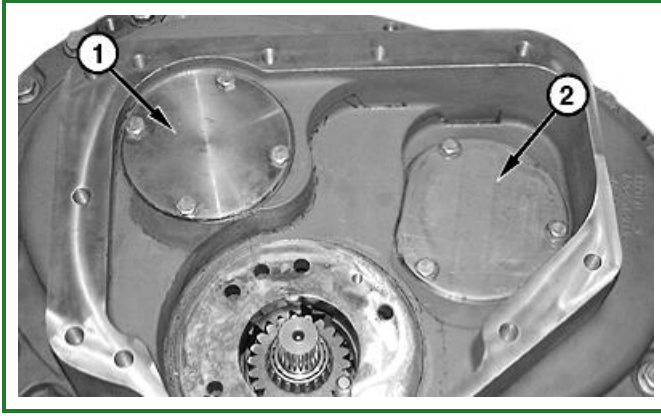

T199777A-UN: Covers

LEGEND:

- 1 - Axle Shaft Cover
- 2 - Second Idler Pinion Gear Cover

Remove axle shaft cover (1) and second idler pinion gear cover (2).

5.

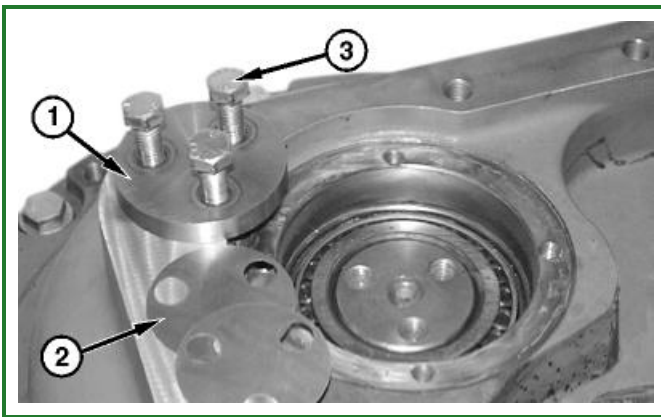

T199779A-UN: Axle Shaft Shims and Retaining Plate

LEGEND:

- 1 - Retaining Plate
- 2 - Shims
- 3 - Cap Screws (3 used)

Remove cap screws (3), retaining plate (1) and shims (2).

6.

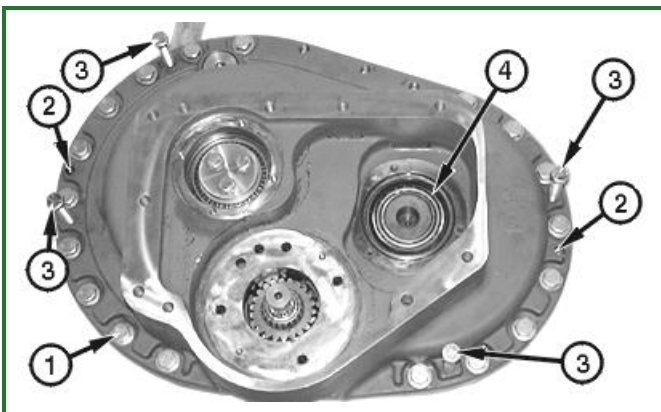

T199780A-UN: Jack Screw

LEGEND:

- 1 - Cap Screws (24 used)
- 2 - Dowel Pins (2 used)

3 - Jack Screws (4 used)

4 - O-Ring

Remove housing cap screws (1).

7. Remove housing alignment dowel pins (2).

8. **NOTE:**

The axle shaft inner bearing cone is pressed into the housing. Jack screws are needed to pull housing with bearing cone from shaft. Turn jack screws equally while separating housing halves.

Separate housing halves by installing jack screws (3).

9. Remove O-ring (4).

10.

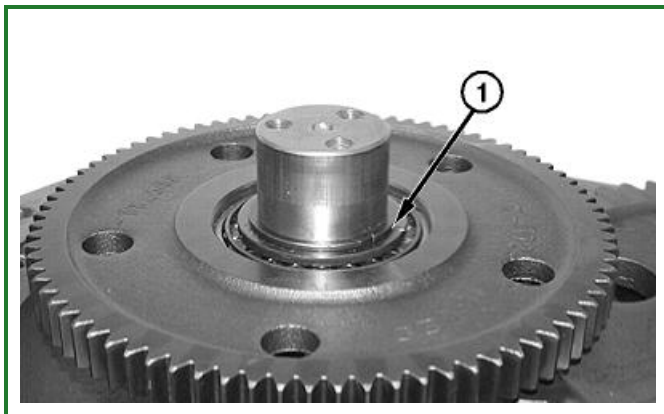

T118848B-UN: Snap Ring

LEGEND:

1 - Snap Ring

Remove snap ring (1) from axle shaft.

11.

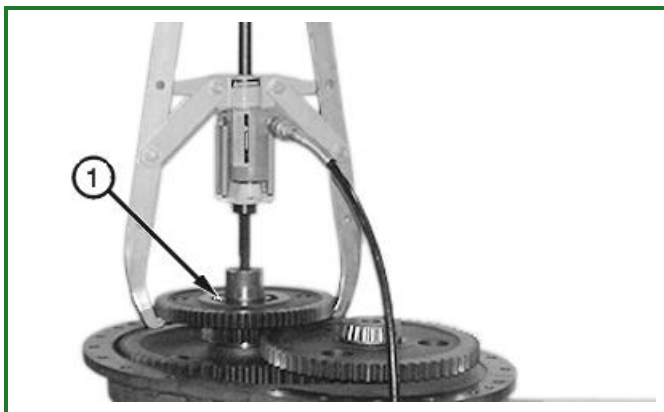

T118849B-UN: First Idler Cluster Gear

LEGEND:

1 - First Idler Cluster Gear

Remove first idler cluster gear (1) with bearing.

12.

NOTE:

Remove second idler ring and pinion gear assembly with final drive gear partially pulled up axle shaft.

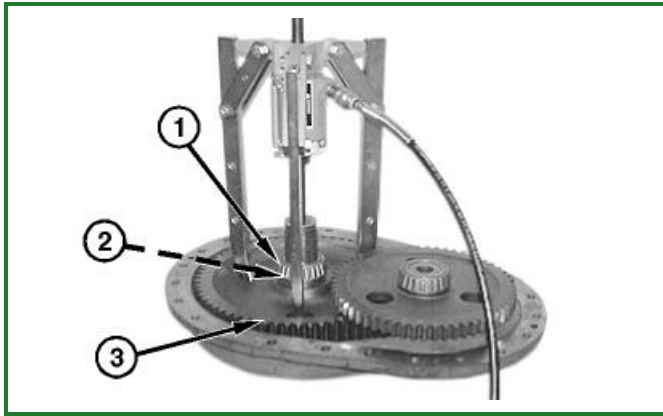

T118850B-UN: Final Drive Gear

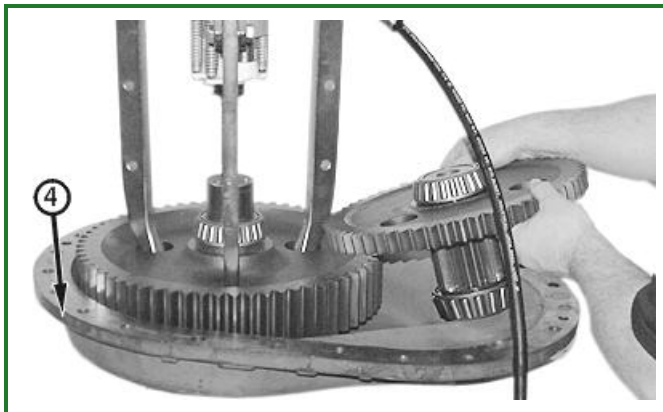

T119800B-UN: Second Idler Pinion Gear Assembly

LEGEND:

- 1 - Bearing
- 2 - Spacer
- 3 - Gear
- 4 - Housing Half

Remove final drive gear (3) with bearing (1) and spacer (2).

13. Remove final drive gear spacer from axle shaft.

14. Lift housing half (4) off of axle shaft.

15.

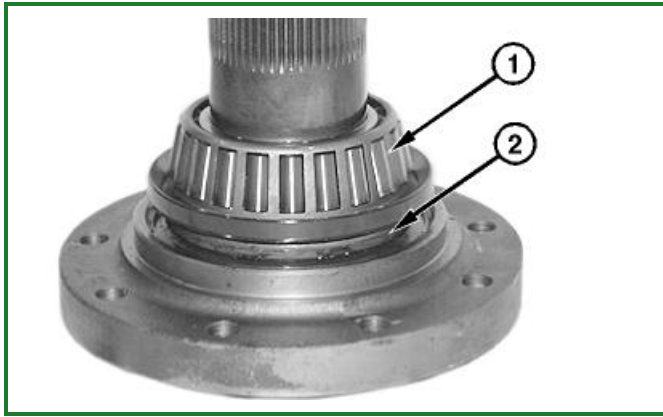
**T118852B-UN: Axle Shaft Bearing and Seal****LEGEND:**

1 - Bearing

2 - Seal

Remove bearing (1) from axle shaft.

16. Remove and discard seal assembly (2).

17. Clean and inspect housing and parts.

18.

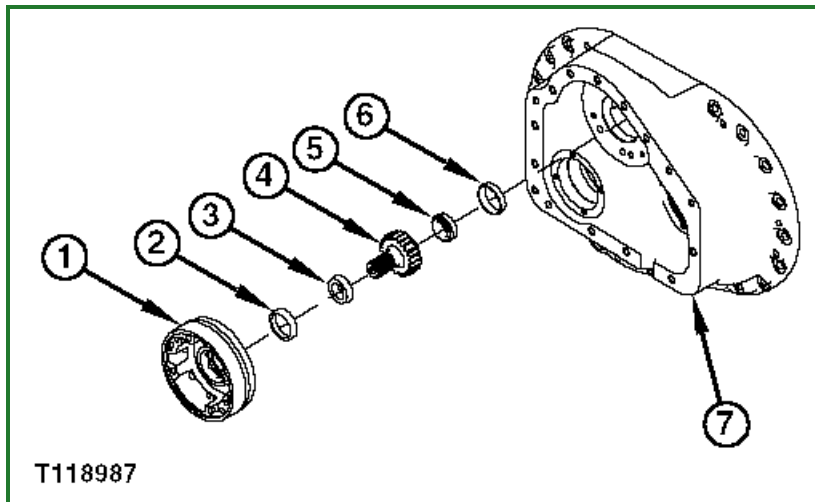
**T118987-UN: Final Drive Input Gear****LEGEND:**

1 - Brake Housing

2 - Bearing Cup

3 - Bearing Cone

4 - Final Drive Input Gear

5 - Bearing Cone

6 - Bearing Cup

7 - Housing

Remove parts (2—6) as shown.

19. Inspect final drive input gear (4) and bearing cones (3 and 5). Replace as necessary.

20. Install bearing cup (2) into brake housing.

21. Install bearing cup (6) into housing half (7).
22. Install bearing cones (3 and 5) onto final drive input gear (4).

23.

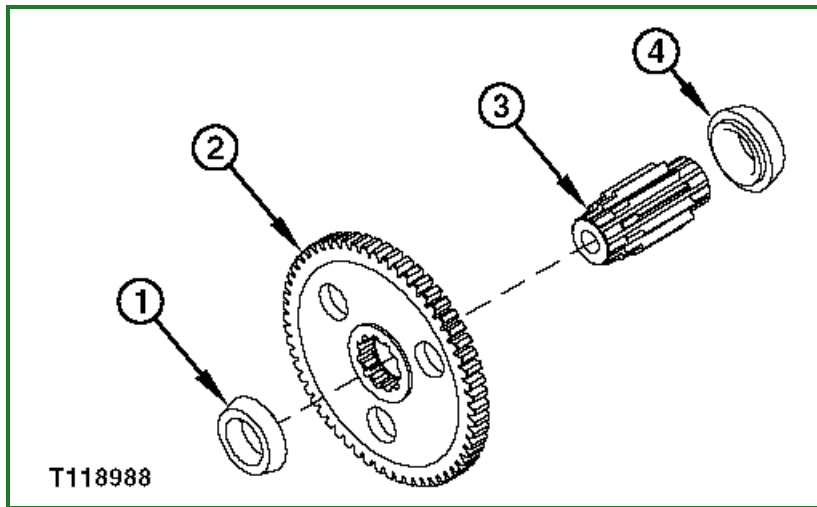

T118988-UN: Second Idler Pinion Gear

LEGEND:

- 1 - Bearing Cone
- 2 - Second Idler Ring Gear
- 3 - Second Idler Pinion Gear
- 4 - Bearing Cone

Remove parts (1—4) as shown.

24. Inspect second idler pinion gear (3) and bearing cones (1 and 4). Replace as necessary.
25. Install bearing cones (1 and 4) onto second idler pinion gear (3).

26.

NOTE:

A snap ring, located in the center of the cluster gear bore, is used to provide proper spacing for bearing cups in assembly.

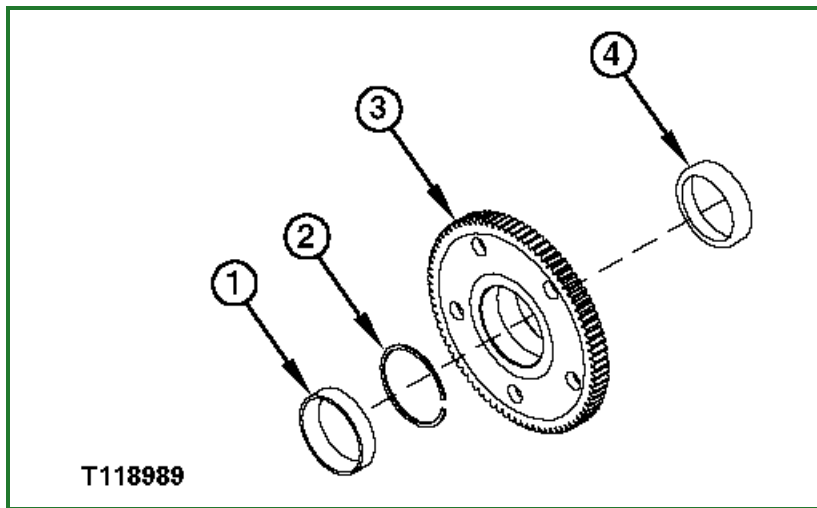

T118989-UN: First Idler Cluster Gear

LEGEND:

- 1 - Bearing Cup
- 2 - Snap Ring
- 3 - First Idler Cluster Gear
- 4 - Bearing Cup

Remove bearing cups (1 and 4) from first idler cluster gear (3).

27. Install bearing cups (1 and 4) into the first idler cluster gear (3). Seat bearing cups on snap ring.

28.

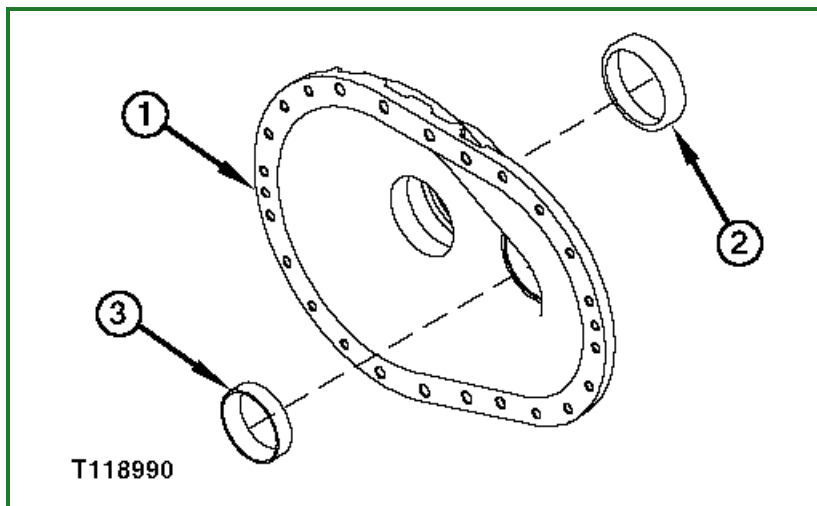

T118990-UN: Seat Bearings in Housing

LEGEND:

- 1 - Housing
- 2 - Final Drive Axle Bearing Cup
- 3 - Second Pinion Outer Bearing Cup

Remove final drive axle bearing cup (2) and second pinion outer bearing cup (3) from final drive housing (1).

29. Install final drive axle bearing cup (2) and second pinion outer bearing cup (3) into final drive housing (1). Fully seat bearing cups in bottom of bores.

30.

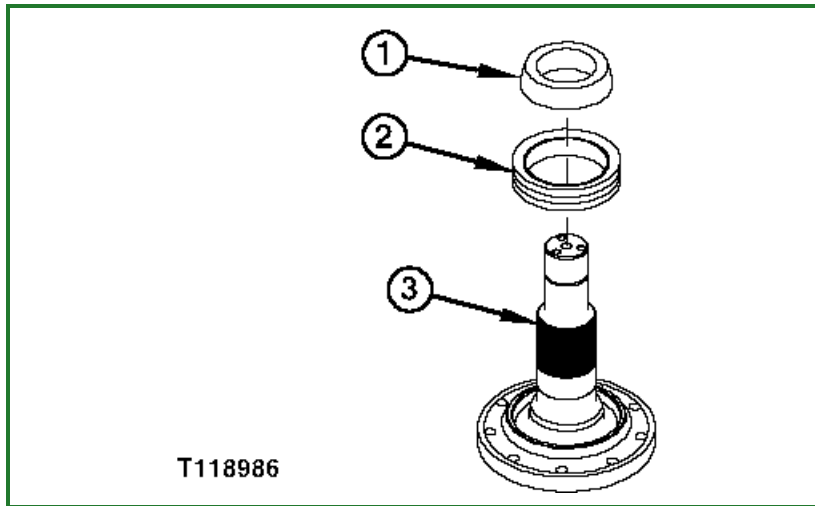
**T118986-UN: Seal Assembly****LEGEND:**

- 1 - Bearing Cone
- 2 - Seal
- 3 - Axle Shaft

Clean seal rubber rings and all surfaces that contact rubber rings with a non-petroleum based solvent. Thoroughly dry parts and surfaces using a lint-free tissue.

31. Install seal assembly (2) onto axle shaft (3).
32. Install bearing cone (1) onto axle shaft (3), tight against shoulder.
33. IMPORTANT:

Special tool JDG1266 Final Drive Seal Protector centers axle in housing during installation. Failure to use the tool will result in a torn or damaged seal assembly.

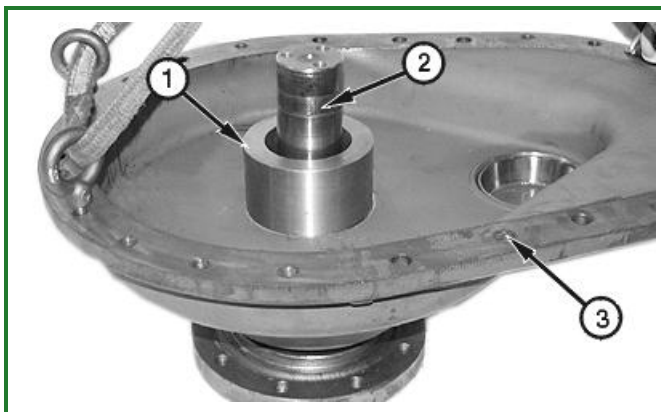
**T118867B-UN: Special Tool, 450J Final Drive****LEGEND:**

- 1 - JDG1266 Final Drive Seal Protector
- 2 - Axle Shaft Assembly
- 3 - Housing

Install special tool (1) JDG1266 in bore of housing.

34. Place axle shaft assembly (2) on level surface.
35. Lower housing (3) onto axle shaft assembly (2).

36.

NOTE:

Axle shaft and housing must be square and level for assembly.

With the weight of the housing on the axle flange, block and support housing using a level.

37. Disconnect hoist and remove special tool (1).

38.

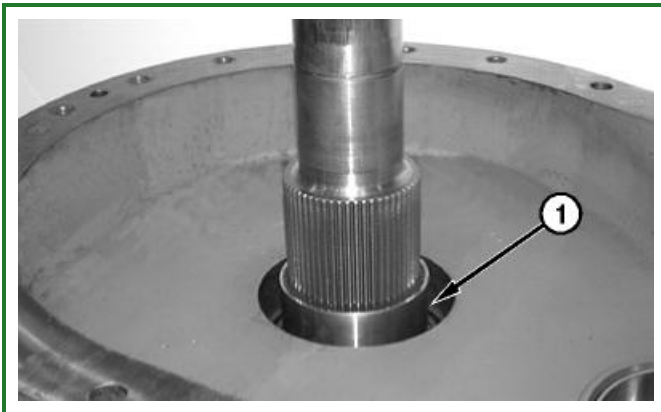

T118854B-UN: Final Drive Gear Spacer

LEGEND:

1 - Final Drive Gear Spacer

Install final drive gear spacer (1) onto axle shaft.

39.

NOTE:

Install second idler pinion gear assembly (2) after final drive gear (1) is lowered halfway into position.

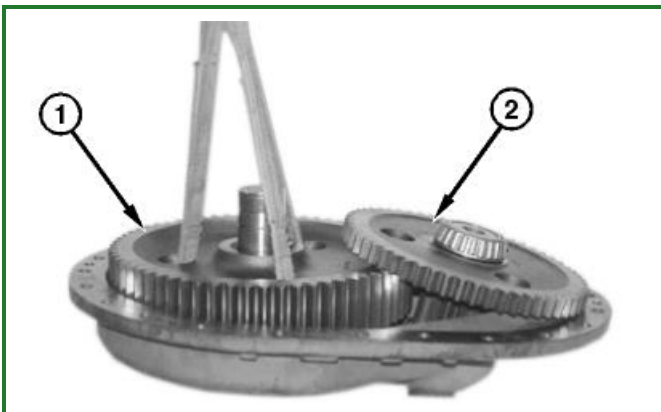

T118855B-UN: Final Drive Gear and Pinion Gear Assembly

LEGEND:

1 - Final Drive Gear

2 - Second Idler Pinion Gear Assembly

Install final drive gear (1).

40.

⚠ CAUTION:

DO NOT heat oil over 182°C (360°F). Oil fumes or oil can ignite above 193°C (380°F). Use a thermometer. **DO NOT** allow flame or heater element to come in direct contact with the oil. Heat oil in a well ventilated area.

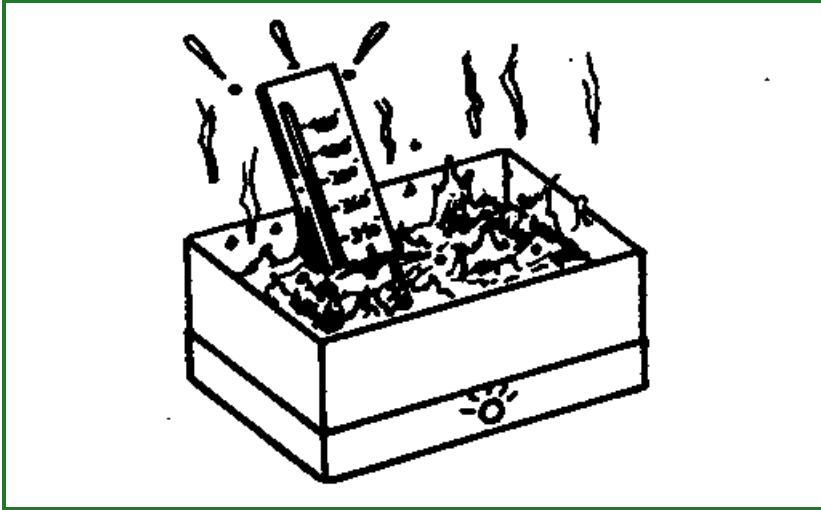

T81191-UN: Heat Oil

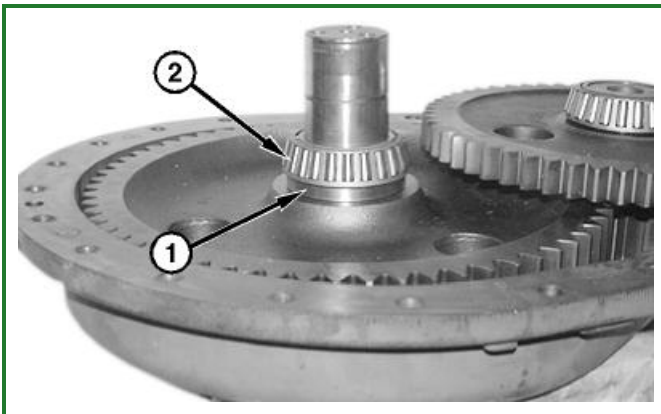

T118856B-UN: Bearing Cone

LEGEND:

- 1 - Spacer
- 2 - Bearing Cone

Install spacer (1) onto axle shaft with chamfer side toward gear.

41. Heat bearing cone (2) and install onto axle shaft above spacer (1).

42.

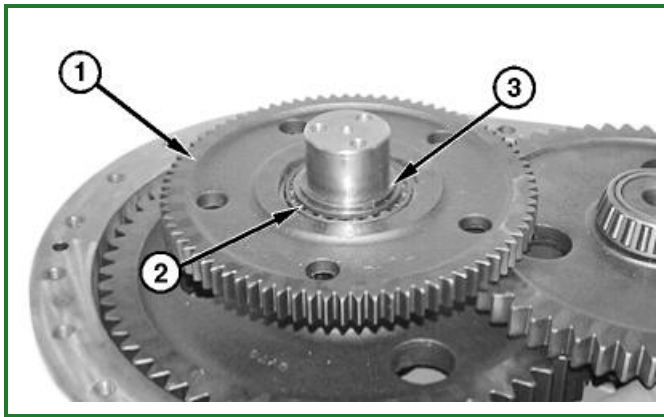
**T118857B-UN: Bearing and Snap Ring****LEGEND:**

- 1 - First Idler Cluster Gear
- 2 - Bearing Cone
- 3 - Snap Ring

Install first idler cluster gear (1).

43. Heat bearing cone (2) and install onto axle shaft.

44. Install snap ring (3) onto axle shaft.

Select the appropriate snap ring (3) by checking end play on first idler cluster gear and compare to following specifications.

Item	Measurement	Specification
Final Drive		
Final Drive First Idler Cluster Gear	End Play	0—0.228 mm 0—0.009 in.

45.

**T119802B-UN: Final Drive Housing****LEGEND:**

- 1 - Dowel Pins (2 used)

Install housing alignment dowel pins (1) in housing half.

46. Apply PM37509 Cure Primer and PM38656 Thread Lock and Sealer (high strength) to housing sealing surface.

47. Join housing halves.

48. Install cap screws and tighten evenly to specifications.

Item	Measurement	Specification
Final Drive		
Final Drive Housing Cap Screws	Initial Torque	135 N·m 100 lb-ft
	Final Torque	320 N·m 235 lb-ft

49.

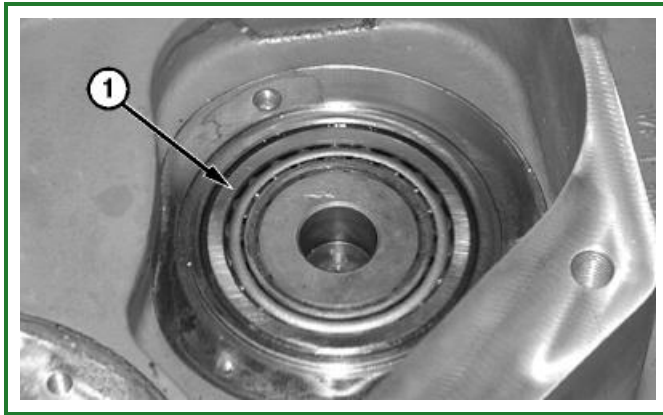

T199786A-UN: Second Pinion Gear Bearing Cup

LEGEND:

1 - Bearing Cup

Seat bearing cup (1) onto bearing cone.

50.



T199781A-UN: Second Idler Pinion Gear Shaft End Play Measurement

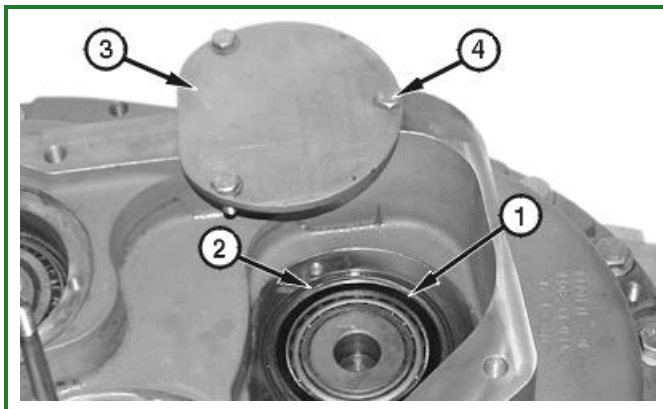

T199782A-UN: Retaining Plate

LEGEND:

- 1 - Shims
- 2 - O-Ring
- 3 - Cover
- 4 - Cap Screw (3 used)

Measure distance between housing and bearing cone. Add shims (1) to achieve specified preload-end play.

Item	Measurement	Specification
Final Drive		
Final Drive Pinion Shaft Preload-End Play		0.025 mm preload—0.152 mm end play 0.001 in. preload—0.005 in. end play

- 51. Install O-ring (2).
- 52. Install cover with three cap screws (4) and tighten to specifications.

Item	Measurement	Specification
Final Drive		
Final Drive Pinion Shaft Cover Cap Screws	Torque	80 N·m 60 lb-ft

53.

⚠ CAUTION:

DO NOT heat oil over 182°C (360°F). Oil fumes or oil can ignite above 193°C (380°F). Use a thermometer. DO NOT allow flame or heater element to come in direct contact with the oil. Heat oil in a well ventilated area.

NOTE:

Housing and axle shaft flange must be level, with weight of housing on axle flange.

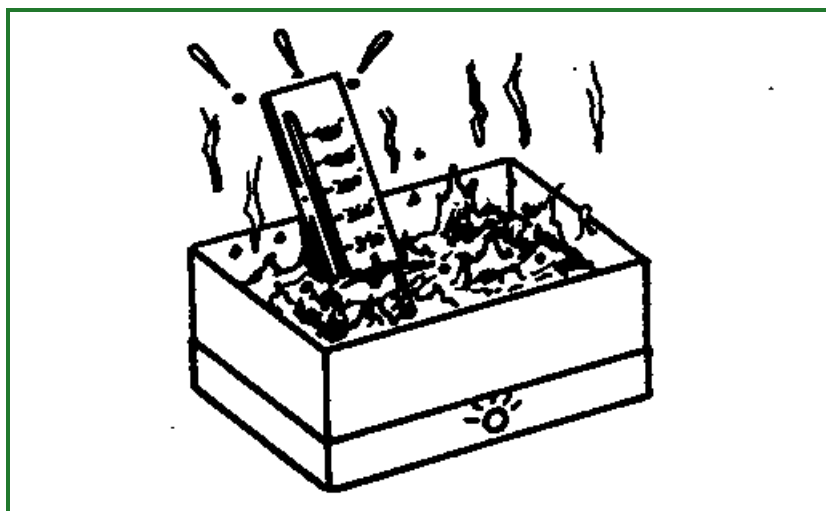

T81191-UN: Heat Oil

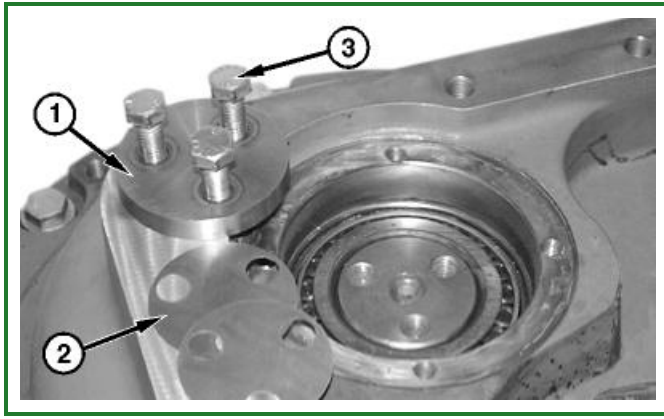

T199779A-UN: Axle Shaft Shims and Retaining Plate

LEGEND:

- 1 - Retaining Plate
- 2 - Shims
- 3 - Cap Screws (3 used)

Heat bearing and install onto axle shaft.

- 54. Install shims (2) removed initially, and add an additional 0.508 mm (0.020 in.) shims to provide an end play on axle shaft.
- 55. Install retaining plate (1).
- 56. Tighten retaining plate cap screws to specification (3).

Item	Measurement	Specification
Final Drive		
Retaining Plate Cap Screws	Torque	156 N·m 115 lb-ft

- 57. Attach final drive housing to a hoist.
- 58. Lift final drive and rotate axle and tap on retaining cap with hammer and punch. Torque cap screws again to specification. Repeat this step until cap screws do not turn when tightened after tapping retainer plate.

59.

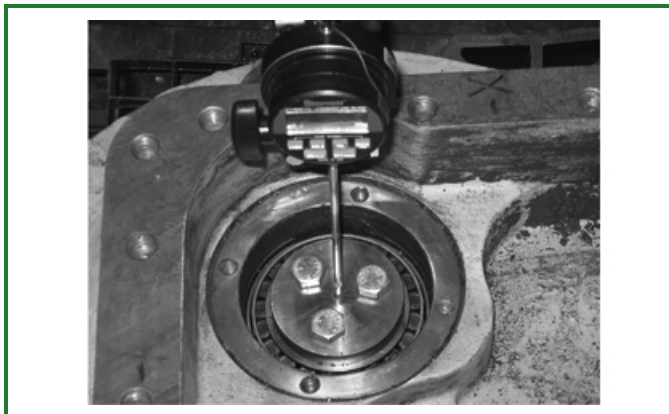

TX1054194A-UN: Axle Preload Adjustment

Place dial indicator at the exact center of retaining cap as shown and adjust to zero.

- 60. Lower final drive assembly until axle shaft flange is on a level surface with weight of final drive housing on axle flange and bearing. Loosen hoist chains, balance and rotate final drive housing by hand. Record indicator maximum reading.
- 61. The maximum dial indicator reading will be the axle shaft bearing end play.
- 62. Remove retaining plate and adjust shims as required to obtain specified axle shaft preload.

Item	Measurement	Specification
Final Drive		
Final Drive Axle Shaft Preload	Preload	0.05 mm—0.155 mm 0.002—0.006 in.

- 63. Apply PM37509 Cure Primer and PM38656 Thread Lock and Sealer (high strength) to retaining plate cap screws and tighten to specifications.

Item	Measurement	Specification
Final Drive		
Final Drive Axle Shaft Retaining Plate Cap Screws	Torque	156 N·m 115 lb-ft

64.

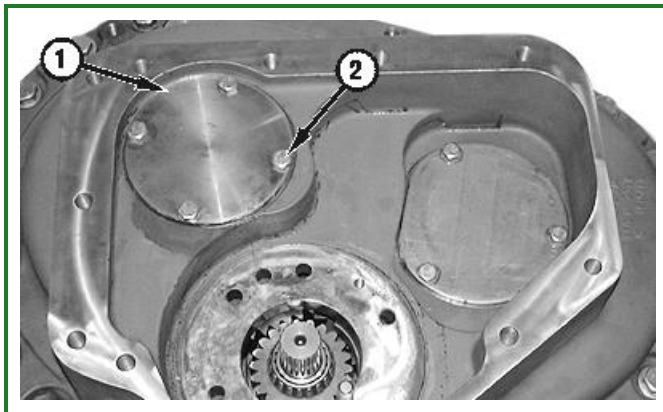

T199784A-UN: Axle Shaft Cover

LEGEND:

- 1 - Cover Plate
- 2 - Cap Screws (4 used)

Apply PM37509 Cure Primer and PM38656 Thread Lock and Sealer (high strength) to axle shaft cover plate (1). Install cover and tighten cap screws to specifications.

Item	Measurement	Specification
Final Drive		
Final Drive Axle Shaft Cover Plate Cap Screws	Torque	80 N·m 60 lb-ft

65.

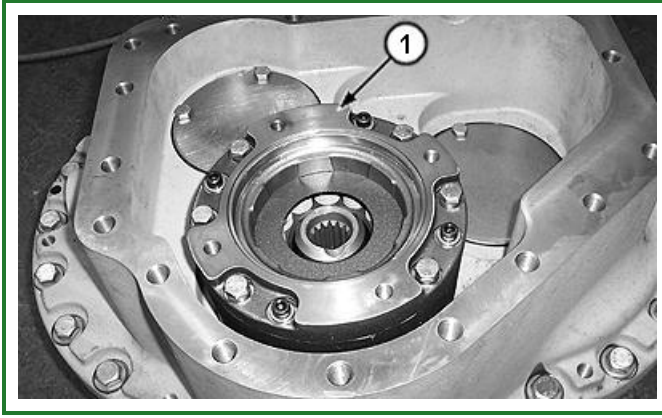
**T199297A-UN: Park Brake Assembly**

Install park brake assembly. [See Park Brake Remove and Install](#) . (Group 1100.)

66.

⚠ CAUTION:

Use only regulated, compressed air of 34.5 kPa (0.345 bar) (5 psi) maximum to check seal on final drive housing. If high pressure compressed air is used, premature case seal failure can occur.

Wear proper face and body protection when using compressed air.

Install a 0—15 psi gauge and shut-off valve in the housing oil fill hole.

67. Using a regulated air source, apply a maximum of 34.5 kPa (0.345 bar) (5 psi) to case and close shut-off valve.
68. Observe pressure gauge for five minutes. If any pressure drop occurs, the housing must be checked for leaks and resealed.

Go to [Section_02:Group_0250](#)

TE14778,0000024-19-20150504

Final Drive Disassemble and Assemble

NOTE:

450J shown unless otherwise indicated.

1.

NOTE:

The approximate capacity of each final drive is 8.5 L (9 qt).

Drain oil from final drive.

2.

⚠ CAUTION:

Final drive assembly weighs approximately 340 kg (750 lbs). Use proper lifting equipment and safety precautions. Failure to do so may cause personal injury.

Block and support final drive on heavy-duty bench.

Item	Measurement	Specification
Final Drive Assembly	Weight	340 kg Approximate 750 lb Approximate

3.

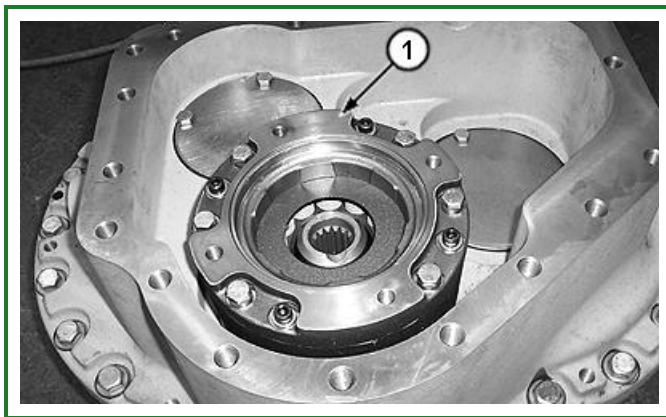

T199297A-UN: Park Brake Assembly

Remove park brake assembly. See [Park Brake Remove and Install](#) . (Group 1100.)

4.

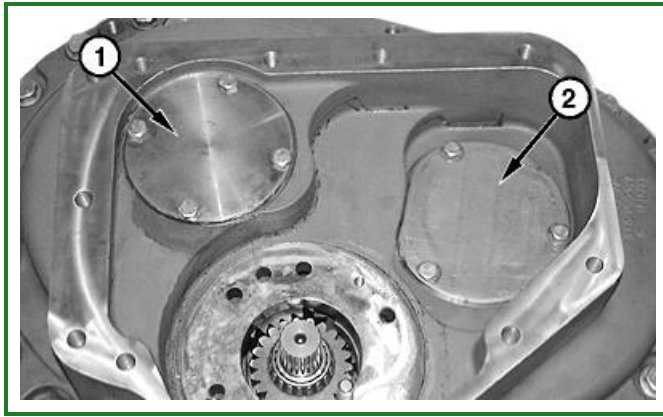

T199777A-UN: Covers

LEGEND:

- 1 - Axle Shaft Cover
- 2 - Second Idler Pinion Gear Cover

Remove axle shaft cover (1) and second idler pinion gear cover (2).

5.

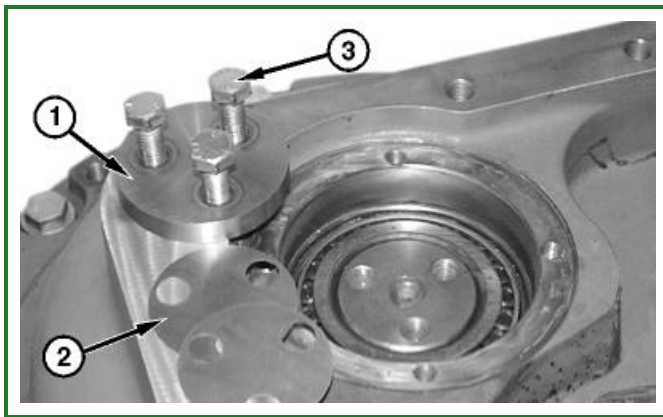

T199779A-UN: Axle Shaft Shims and Retaining Plate

LEGEND:

- 1 - Retaining Plate
- 2 - Shims
- 3 - Cap Screws (3 used)

Remove cap screws (3), retaining plate (1) and shims (2).

6.

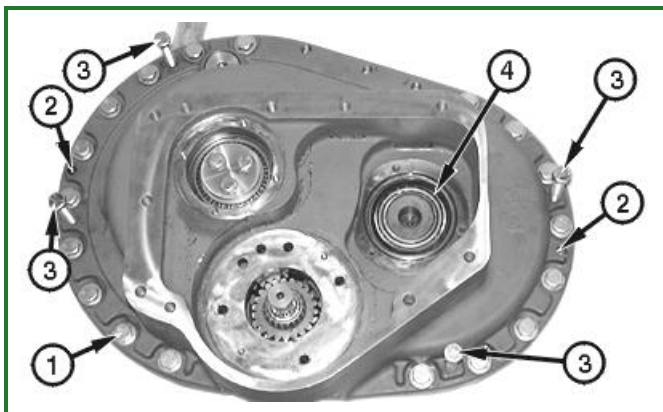

T199780A-UN: Jack Screw

LEGEND:

- 1 - Cap Screws (24 used)
- 2 - Dowel Pins (2 used)

3 - Jack Screws (4 used)

4 - O-Ring

Remove housing cap screws (1).

7. Remove housing alignment dowel pins (2).

8. **NOTE:**

The axle shaft inner bearing cone is pressed into the housing. Jack screws are needed to pull housing with bearing cone from shaft. Turn jack screws equally while separating housing halves.

Separate housing halves by installing jack screws (3).

9. Remove O-ring (4).

10.

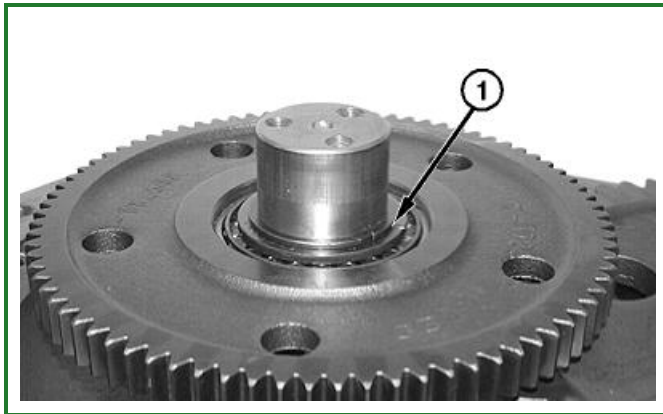

T118848B-UN: Snap Ring

LEGEND:

1 - Snap Ring

Remove snap ring (1) from axle shaft.

11.

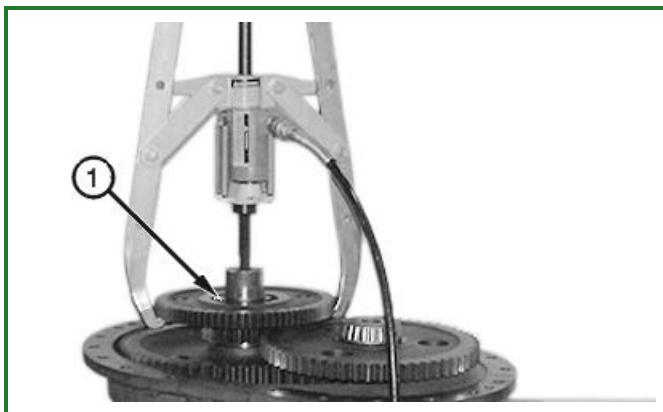

T118849B-UN: First Idler Cluster Gear

LEGEND:

1 - First Idler Cluster Gear

Remove first idler cluster gear (1) with bearing.

12.

NOTE:

Remove second idler ring and pinion gear assembly with final drive gear partially pulled up axle shaft.

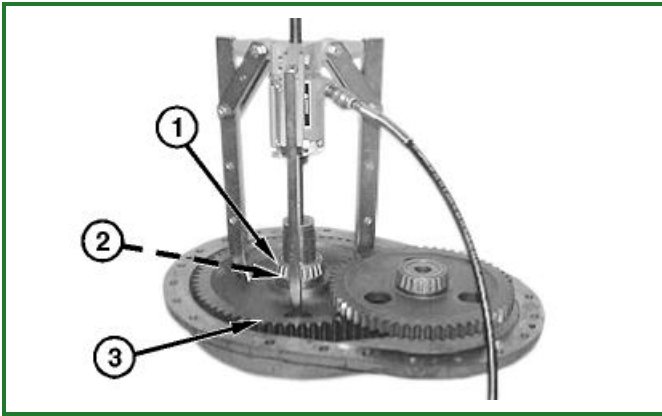

T118850B-UN: Final Drive Gear

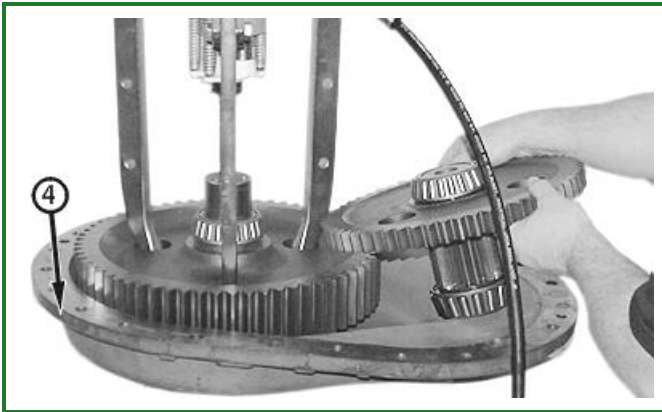

T119800B-UN: Second Idler Pinion Gear Assembly

LEGEND:

- 1 - Bearing
- 2 - Spacer
- 3 - Gear
- 4 - Housing Half

Remove final drive gear (3) with bearing (1) and spacer (2).

13. Remove final drive gear spacer from axle shaft.

14. Lift housing half (4) off of axle shaft.

15.

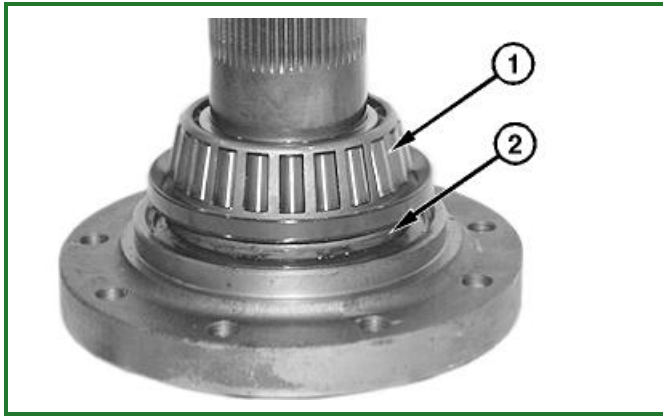
**T118852B-UN: Axle Shaft Bearing and Seal****LEGEND:**

1 - Bearing

2 - Seal

Remove bearing (1) from axle shaft.

16. Remove and discard seal assembly (2).

17. Clean and inspect housing and parts.

18.

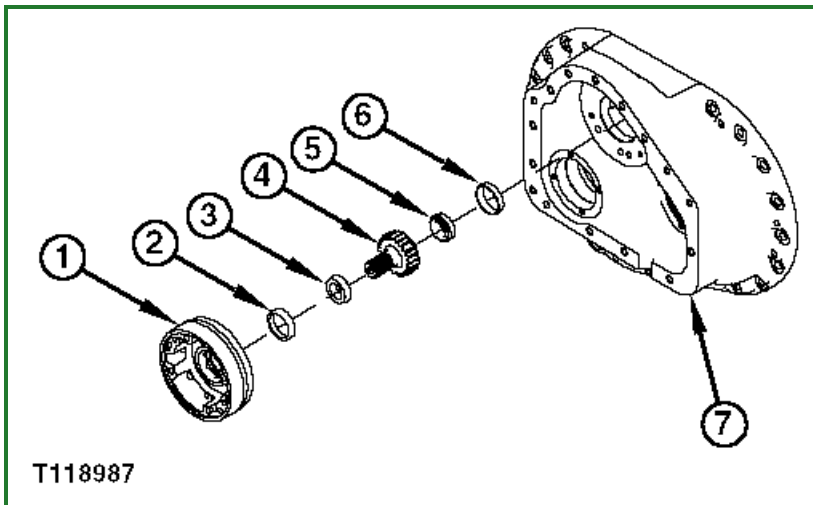

T118987

T118987-UN: Final Drive Input Gear**LEGEND:**

1 - Brake Housing

2 - Bearing Cup

3 - Bearing Cone

4 - Final Drive Input Gear

5 - Bearing Cone

6 - Bearing Cup

7 - Housing

Remove parts (2—6) as shown.

19. Inspect final drive input gear (4) and bearing cones (3 and 5). Replace as necessary.

20. Install bearing cup (2) into brake housing.

21. Install bearing cup (6) into housing half (7).
22. Install bearing cones (3 and 5) onto final drive input gear (4).

23.

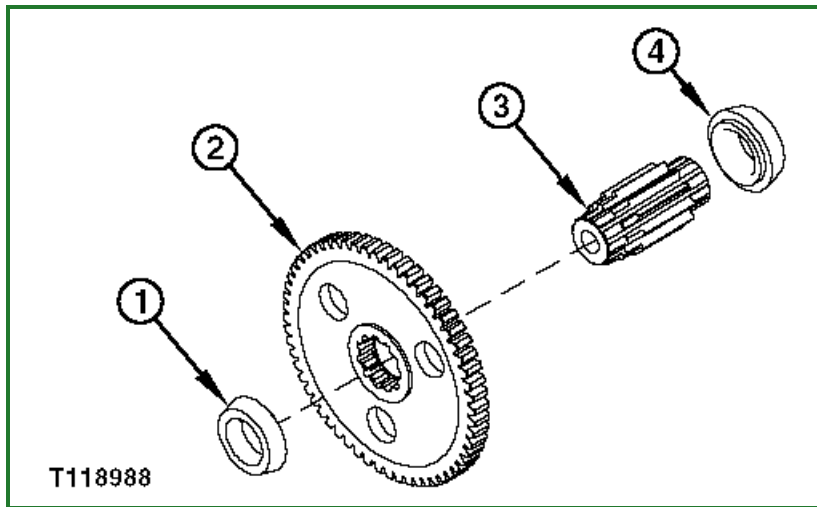

T118988-UN: Second Idler Pinion Gear

LEGEND:

- 1 - Bearing Cone
- 2 - Second Idler Ring Gear
- 3 - Second Idler Pinion Gear
- 4 - Bearing Cone

Remove parts (1—4) as shown.

24. Inspect second idler pinion gear (3) and bearing cones (1 and 4). Replace as necessary.
25. Install bearing cones (1 and 4) onto second idler pinion gear (3).

26.

NOTE:

A snap ring, located in the center of the cluster gear bore, is used to provide proper spacing for bearing cups in assembly.

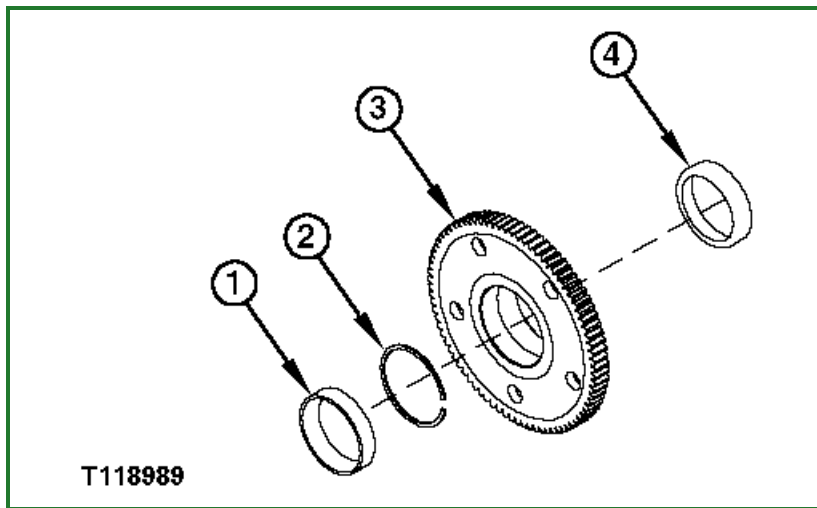

T118989-UN: First Idler Cluster Gear

LEGEND:

- 1 - Bearing Cup
- 2 - Snap Ring
- 3 - First Idler Cluster Gear
- 4 - Bearing Cup

Remove bearing cups (1 and 4) from first idler cluster gear (3).

27. Install bearing cups (1 and 4) into the first idler cluster gear (3). Seat bearing cups on snap ring.

28.

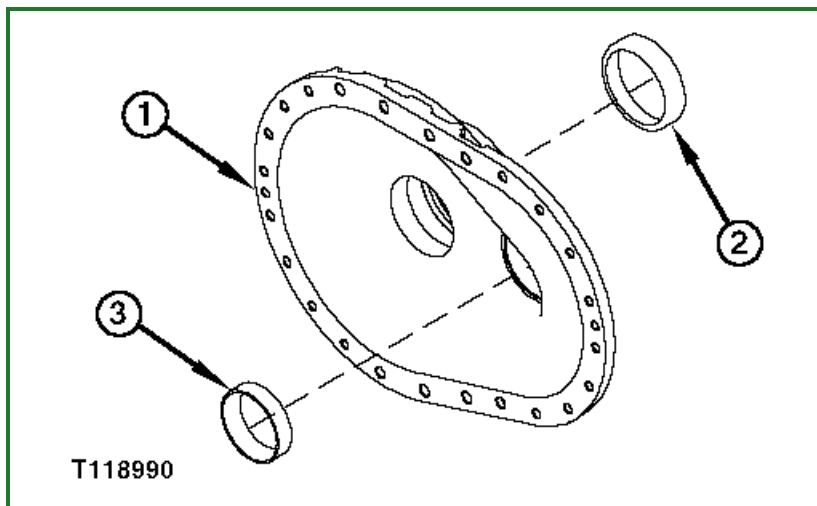

T118990-UN: Seat Bearings in Housing

LEGEND:

- 1 - Housing
- 2 - Final Drive Axle Bearing Cup
- 3 - Second Pinion Outer Bearing Cup

Remove final drive axle bearing cup (2) and second pinion outer bearing cup (3) from final drive housing (1).

29. Install final drive axle bearing cup (2) and second pinion outer bearing cup (3) into final drive housing (1). Fully seat bearing cups in bottom of bores.

30.

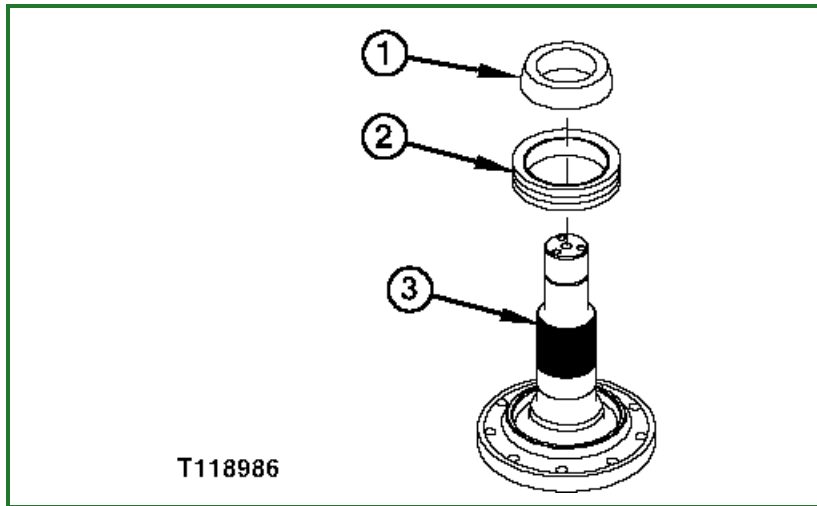
**T118986-UN: Seal Assembly****LEGEND:**

- 1 - Bearing Cone
- 2 - Seal
- 3 - Axle Shaft

Clean seal rubber rings and all surfaces that contact rubber rings with a non-petroleum based solvent. Thoroughly dry parts and surfaces using a lint-free tissue.

31. Install seal assembly (2) onto axle shaft (3).

32. Install bearing cone (1) onto axle shaft (3), tight against shoulder.

33. IMPORTANT:

Special tool JDG1266 Final Drive Seal Protector centers axle in housing during installation. Failure to use the tool will result in a torn or damaged seal assembly.

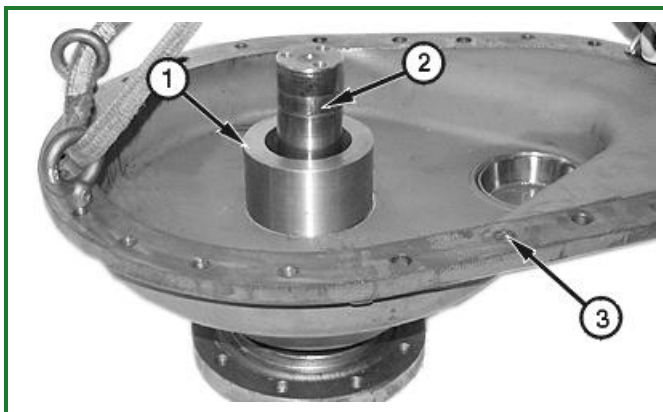
**T118867B-UN: Special Tool, 450J Final Drive****LEGEND:**

- 1 - JDG1266 Final Drive Seal Protector
- 2 - Axle Shaft Assembly
- 3 - Housing

Install special tool (1) JDG1266 in bore of housing.

34. Place axle shaft assembly (2) on level surface.

35. Lower housing (3) onto axle shaft assembly (2).

36.

NOTE:

Axle shaft and housing must be square and level for assembly.

With the weight of the housing on the axle flange, block and support housing using a level.

37. Disconnect hoist and remove special tool (1).

38.

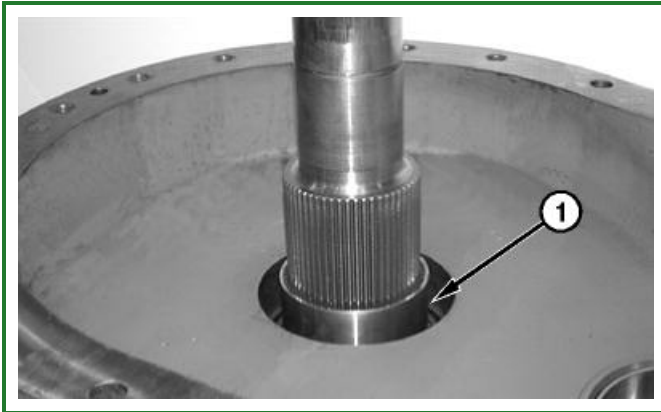

T118854B-UN: Final Drive Gear Spacer

LEGEND:

1 - Final Drive Gear Spacer

Install final drive gear spacer (1) onto axle shaft.

39.

NOTE:

Install second idler pinion gear assembly (2) after final drive gear (1) is lowered halfway into position.

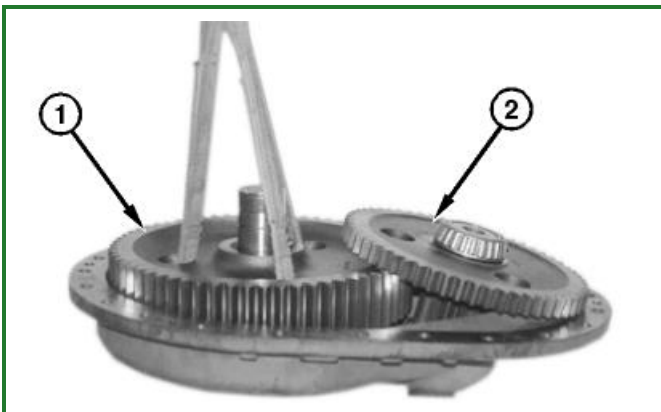

T118855B-UN: Final Drive Gear and Pinion Gear Assembly

LEGEND:

1 - Final Drive Gear

2 - Second Idler Pinion Gear Assembly

Install final drive gear (1).

40.

⚠ CAUTION:

DO NOT heat oil over 182°C (360°F). Oil fumes or oil can ignite above 193°C (380°F). Use a thermometer. **DO NOT** allow flame or heater element to come in direct contact with the oil. Heat oil in a well ventilated area.

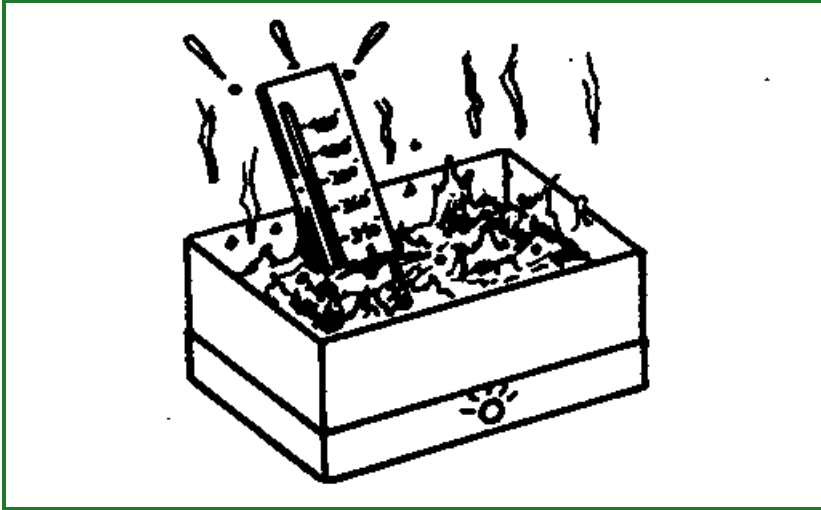

T81191-UN: Heat Oil

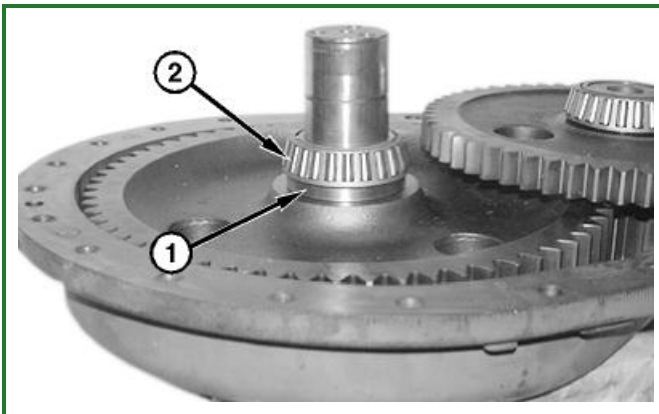

T118856B-UN: Bearing Cone

LEGEND:

- 1 - Spacer
- 2 - Bearing Cone

Install spacer (1) onto axle shaft with chamfer side toward gear.

41. Heat bearing cone (2) and install onto axle shaft above spacer (1).

42.

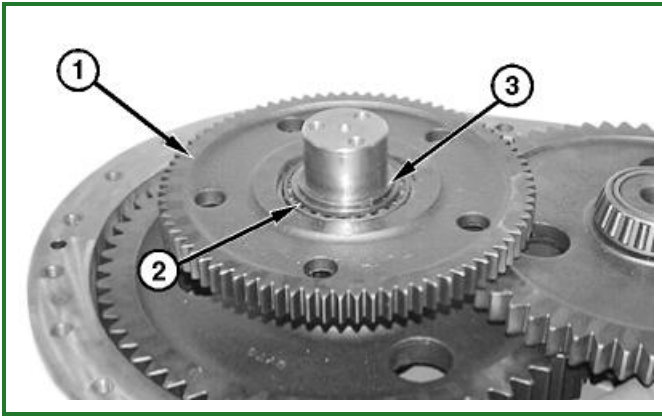
**T118857B-UN: Bearing and Snap Ring****LEGEND:**

- 1 - First Idler Cluster Gear
- 2 - Bearing Cone
- 3 - Snap Ring

Install first idler cluster gear (1).

43. Heat bearing cone (2) and install onto axle shaft.

44. Install snap ring (3) onto axle shaft.

Select the appropriate snap ring (3) by checking end play on first idler cluster gear and compare to following specifications.

Item	Measurement	Specification
Final Drive		
Final Drive First Idler Cluster Gear	End Play	0—0.228 mm 0—0.009 in.

45.

**T119802B-UN: Final Drive Housing****LEGEND:**

- 1 - Dowel Pins (2 used)

Install housing alignment dowel pins (1) in housing half.

46. Apply PM37509 Cure Primer and PM38656 Thread Lock and Sealer (high strength) to housing sealing surface.

47. Join housing halves.

48. Install cap screws and tighten evenly to specifications.

Item	Measurement	Specification
Final Drive		
Final Drive Housing Cap Screws	Initial Torque	135 N·m 100 lb-ft
	Final Torque	320 N·m 235 lb-ft

49.

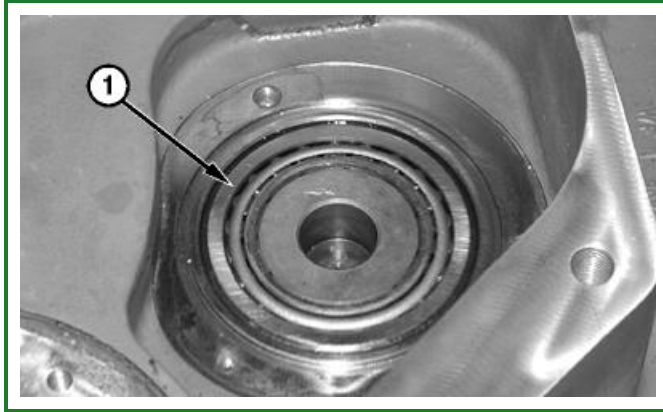

T199786A-UN: Second Pinion Gear Bearing Cup

LEGEND:

1 - Bearing Cup

Seat bearing cup (1) onto bearing cone.

50.



T199781A-UN: Second Idler Pinion Gear Shaft End Play Measurement

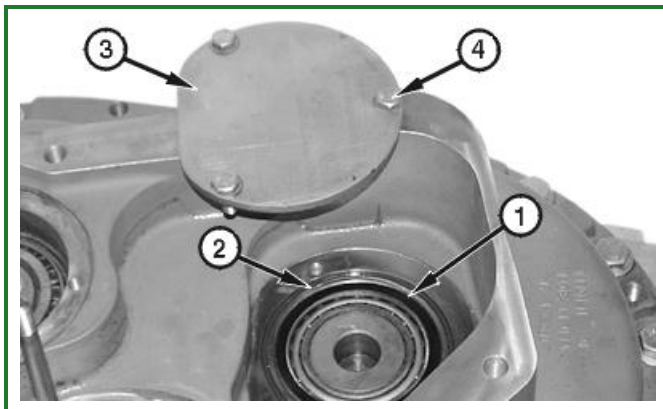

T199782A-UN: Retaining Plate

LEGEND:

- 1 - Shims
- 2 - O-Ring
- 3 - Cover
- 4 - Cap Screw (3 used)

Measure distance between housing and bearing cone. Add shims (1) to achieve specified preload-end play.

Item	Measurement	Specification
Final Drive		
Final Drive Pinion Shaft Preload-End Play		0.025 mm preload—0.152 mm end play 0.001 in. preload—0.005 in. end play

- 51. Install O-ring (2).
- 52. Install cover with three cap screws (4) and tighten to specifications.

Item	Measurement	Specification
Final Drive		
Final Drive Pinion Shaft Cover Cap Screws	Torque	80 N·m 60 lb-ft

53.

⚠ CAUTION:

DO NOT heat oil over 182°C (360°F). Oil fumes or oil can ignite above 193°C (380°F). Use a thermometer. DO NOT allow flame or heater element to come in direct contact with the oil. Heat oil in a well ventilated area.

NOTE:

Housing and axle shaft flange must be level, with weight of housing on axle flange.

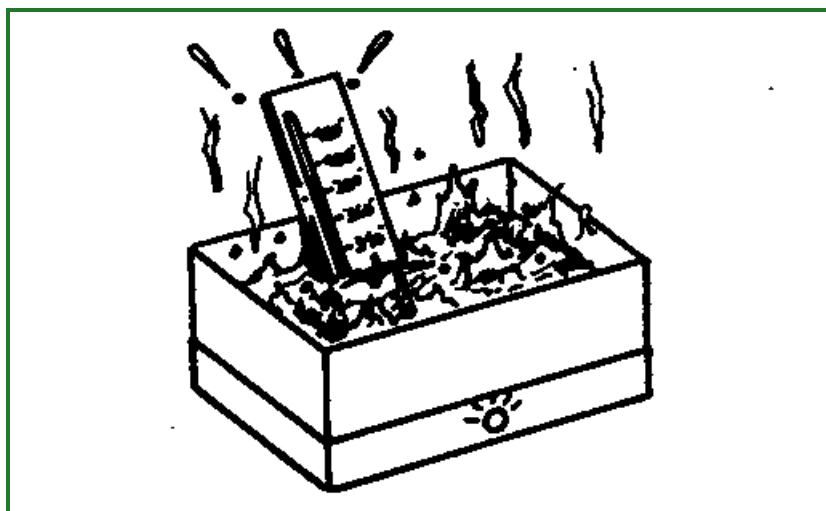

T81191-UN: Heat Oil

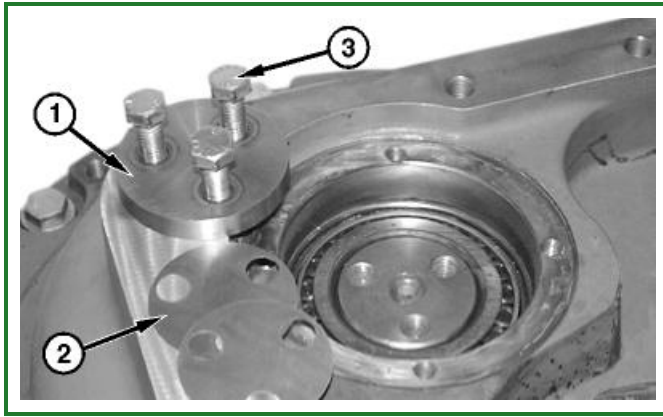

T199779A-UN: Axle Shaft Shims and Retaining Plate

LEGEND:

- 1 - Retaining Plate
- 2 - Shims
- 3 - Cap Screws (3 used)

Heat bearing and install onto axle shaft.

- 54. Install shims (2) removed initially, and add an additional 0.508 mm (0.020 in.) shims to provide an end play on axle shaft.
- 55. Install retaining plate (1).
- 56. Tighten retaining plate cap screws to specification (3).

Item	Measurement	Specification
Final Drive		
Retaining Plate Cap Screws	Torque	156 N·m 115 lb-ft

- 57. Attach final drive housing to a hoist.
- 58. Lift final drive and rotate axle and tap on retaining cap with hammer and punch. Torque cap screws again to specification. Repeat this step until cap screws do not turn when tightened after tapping retainer plate.

59.

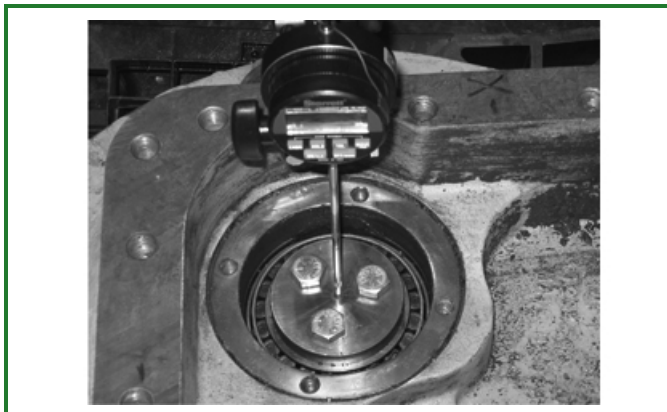

TX1054194A-UN: Axle Preload Adjustment

Place dial indicator at the exact center of retaining cap as shown and adjust to zero.

- 60. Lower final drive assembly until axle shaft flange is on a level surface with weight of final drive housing on axle flange and bearing. Loosen hoist chains, balance and rotate final drive housing by hand. Record indicator maximum reading.
- 61. The maximum dial indicator reading will be the axle shaft bearing end play.
- 62. Remove retaining plate and adjust shims as required to obtain specified axle shaft preload.

Item	Measurement	Specification
Final Drive		
Final Drive Axle Shaft Preload	Preload	0.05 mm—0.155 mm 0.002—0.006 in.

- 63. Apply PM37509 Cure Primer and PM38656 Thread Lock and Sealer (high strength) to retaining plate cap screws and tighten to specifications.

Item	Measurement	Specification
Final Drive		
Final Drive Axle Shaft Retaining Plate Cap Screws	Torque	156 N·m 115 lb-ft

64.

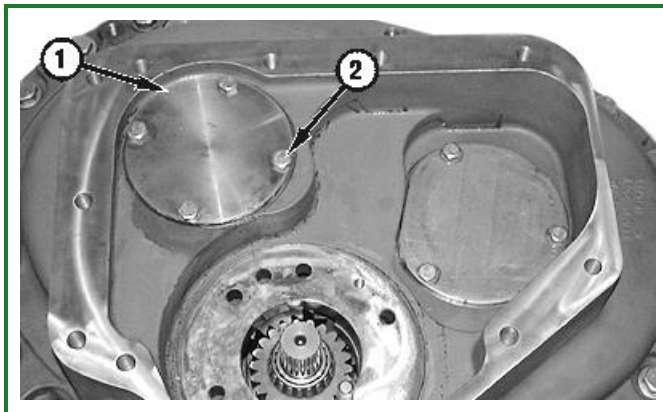

T199784A-UN: Axle Shaft Cover

LEGEND:

- 1 - Cover Plate
- 2 - Cap Screws (4 used)

Apply PM37509 Cure Primer and PM38656 Thread Lock and Sealer (high strength) to axle shaft cover plate (1). Install cover and tighten cap screws to specifications.

Item	Measurement	Specification
Final Drive		
Final Drive Axle Shaft Cover Plate Cap Screws	Torque	80 N·m 60 lb-ft

65.

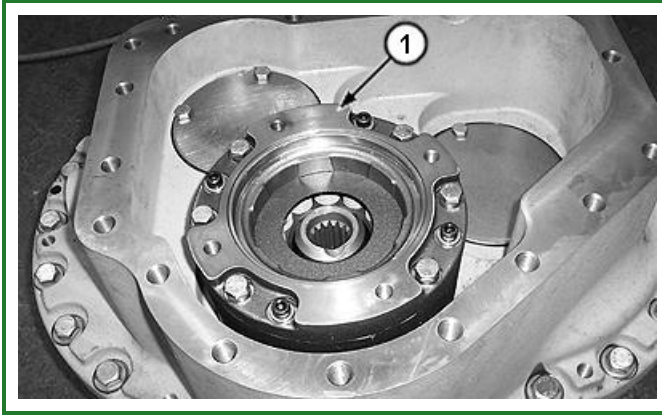
**T199297A-UN: Park Brake Assembly**

Install park brake assembly. [See Park Brake Remove and Install](#) . (Group 1100.)

66.

⚠ CAUTION:

Use only regulated, compressed air of 34.5 kPa (0.345 bar) (5 psi) maximum to check seal on final drive housing. If high pressure compressed air is used, premature case seal failure can occur.

Wear proper face and body protection when using compressed air.

Install a 0—15 psi gauge and shut-off valve in the housing oil fill hole.

67. Using a regulated air source, apply a maximum of 34.5 kPa (0.345 bar) (5 psi) to case and close shut-off valve.
68. Observe pressure gauge for five minutes. If any pressure drop occurs, the housing must be checked for leaks and resealed.

Go to [Section_02:Group_0250](#)

TE14778,0000024-19-20150504

Section 03: Transmission

Group 0300: Removal and Installation

Hydrostatic Pump Remove and Install

Hydrostatic Motor Remove and Install

Group 0315: Controls Linkage

Transmission Control Lever (TCL) Remove and Install

Transmission Control Lever (TCL) Disassemble and Assemble (S.N. —130885)

Group 0360: Hydrostatic System

Hydrostatic Pumps Disassemble

Hydrostatic Charge Pump Disassemble and Assemble

Pump Displacement Control Valve (PDCV) Disassemble and Assemble

Multi-Function Valve Disassemble and Assemble

Neutral Charge Relief Valve Disassemble and Assemble

Hydrostatic Pump Assemble

Hydrostatic Motor Disassemble

Hydrostatic Motor Assemble

Oil Cooler Thermal Bypass Valve Remove and Install

Hydrostatic Filter Remove and Install

Hydrostatic Filter Disassemble and Assemble

Hydrostatic Reservoir Remove and Install

Hydrostatic Pump Remove and Install



T116758B-UN: Seat Base Cap Screws

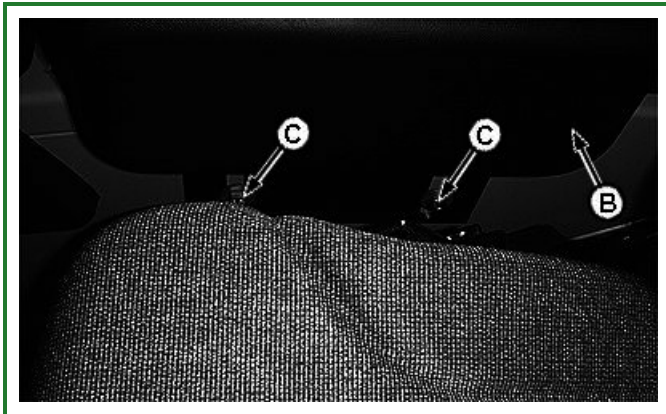

T116757B-UN: Seat Armrest Cap Screws

LEGEND:

- A - Cap Screws Around Seat Box Bottom (4 used)
- B - Armrest
- C - Shoulder Cap Screws (2 used)
- E - Knee Pad

1.

⚠ CAUTION:

Prevent possible injury from unexpected track movement. Raise the machine off the ground and support with blocks. Tracks MUST be free to rotate in either direction to perform Hydrostatic Pump Initial Startup Procedure and Pump Displacement Control Valve Neutral (Null) Adjustment.

Raise machine off the ground and support with blocks. Lower blade to ground. Tracks MUST be free to rotate in either direction.

2. Turn battery disconnect switch to OFF.

3.

NOTE:

The approximate capacity of hydrostatic reservoir is 43 L (11.3 gal).

Remove access plate from bottom of hydrostatic reservoir compartment and drain reservoir.

4. **NOTE:**

The approximate capacity of engine coolant is 11.3 L (3 gal).

If equipped with heater, drain engine coolant.

5. Remove floor mat and floor access plate.
6. For machines with toolbox, pull out drawer and remove cap screw holding toolbox in place. Remove toolbox from machine.
7. Remove four cap screws (A) from around seat box bottom.
8. Remove shoulder cap screws (C) from seat box under armrest (B) on both sides of seat.
9. Remove two cap screws from knee pad (E) on both sides of seat.
10. **IMPORTANT:**
Observe control levers as seat is being raised or lowered for possible interference.

Loosen jam nut on hydraulic control lever tee handle and index handle 90° to provide clearance for seat when tilting.
11. On units equipped with rear screen or cab, tilt back of seat forward.

12.

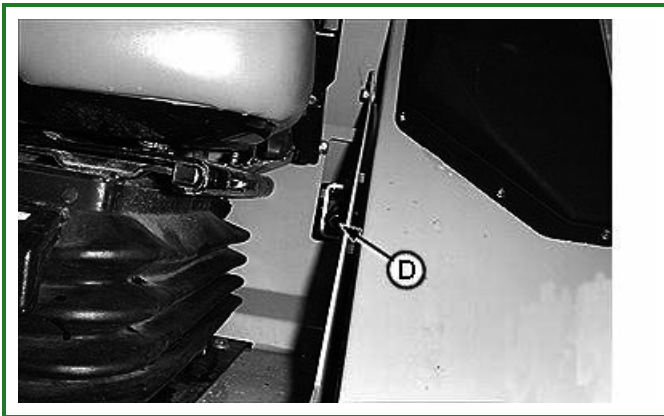

T200435A-UN: Jack Screw

LEGEND:

D - Jack Screw

Tilt seat up as far as possible with jack screw (D) located in left rear corner of seat box.

13.

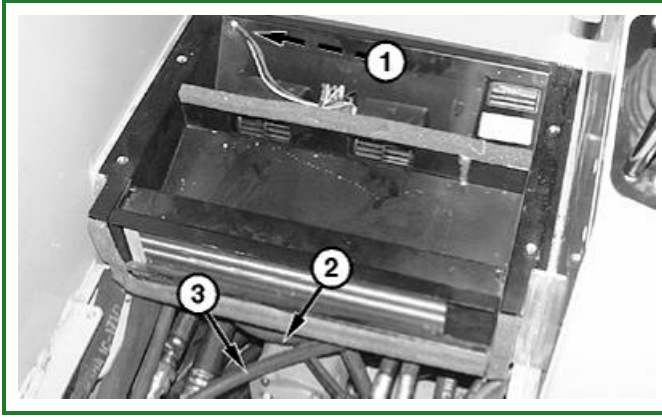
**T118838B-UN: Heater****LEGEND:**

- 1 - Blower Harness Connector
- 2 - Heater Hose
- 3 - Heater Hose

Disconnect blower harness connector (1) and heater hoses (2 and 3).

14. Remove heater assembly.

15.

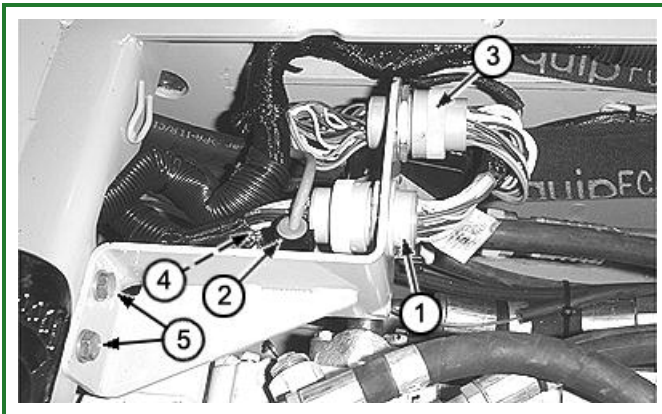
**T200959A-UN: Harness Connections****LEGEND:**

- 1 - Engine Harness Connector
- 2 - Engine Harness Connector
- 3 - Transmission Harness Connector
- 4 - Heater Valve Clamp (Cab units only) (2 used)
- 5 - Bracket Cap Screw (2 used)

Disconnect engine harness connectors (1 and 2) and transmission harness connector (3).

16. Disconnect engine harness connector (1) from bracket.

17. Loosen hose clamps (4) from heater valve and disconnect heater valve from bracket. (Do not disconnect hoses from heater valve).

18. Remove cap screws (5) from bracket and move bracket, wiring and hoses off to side.

19.

⚠ CAUTION:

To avoid injury from escaping fluid under pressure, stop engine and relieve the pressure in the system before disconnecting or connecting hydraulic or other lines. Tighten all connections before applying pressure.

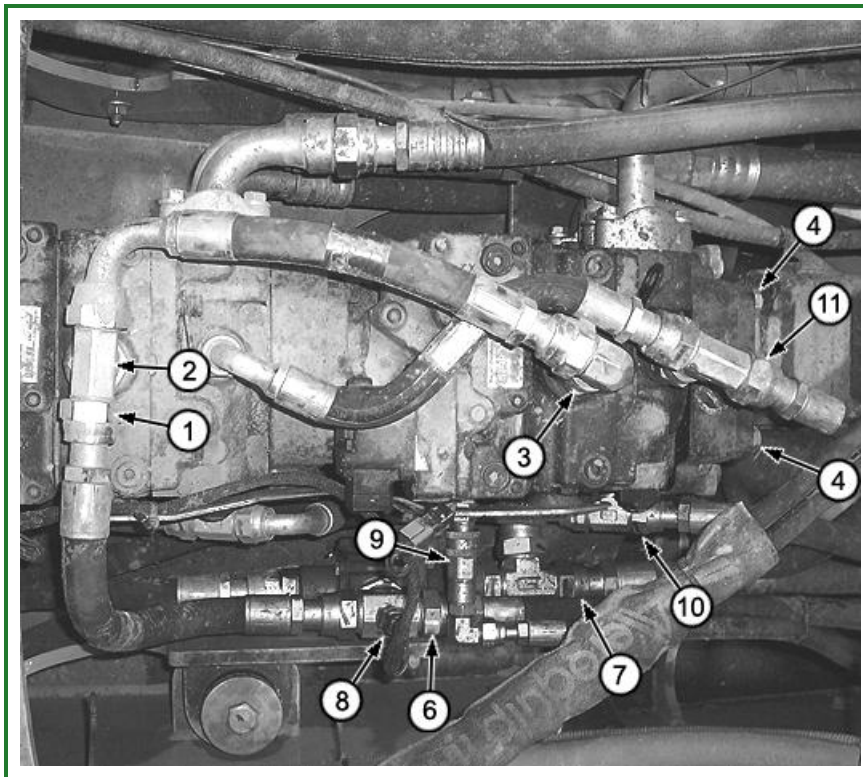

T200359A-UN: Hydrostatic Pumps

LEGEND:

- 1 - Line (Front Pump Tee Fitting-to-Cooler Bypass Valve)
- 2 - Tee Fitting (Front Pump)
- 3 - Line Fitting (Rear Pump)
- 4 - Hydraulic Pump Mounting Cap Screws (4 used)
- 5 - Not Used
- 6 - Line (Oil Cooler Bypass Valve-to-Reservoir)
- 7 - Line (Left Motor Tee Fitting-to-Oil Cooler Bypass Valve)
- 8 - Oil Cooler Bypass Valve Wire Terminal
- 9 - Line (Park Brake)
- 10 - Line (Oil Filter-to-Charge Pump)
- 11 - Line (Charge Pump-to-Oil Filter)

Disconnect line (1). Close all openings using caps and plugs.

- 20. Disconnect fittings (2 and 3) and remove line.
- 21. Disconnect lines (6, 7, 9, and 10).
- 22. Disconnect wire terminal (8).
- 23. Remove cap screws (4) from hydraulic pump and remove pump. Set pump aside.

24.

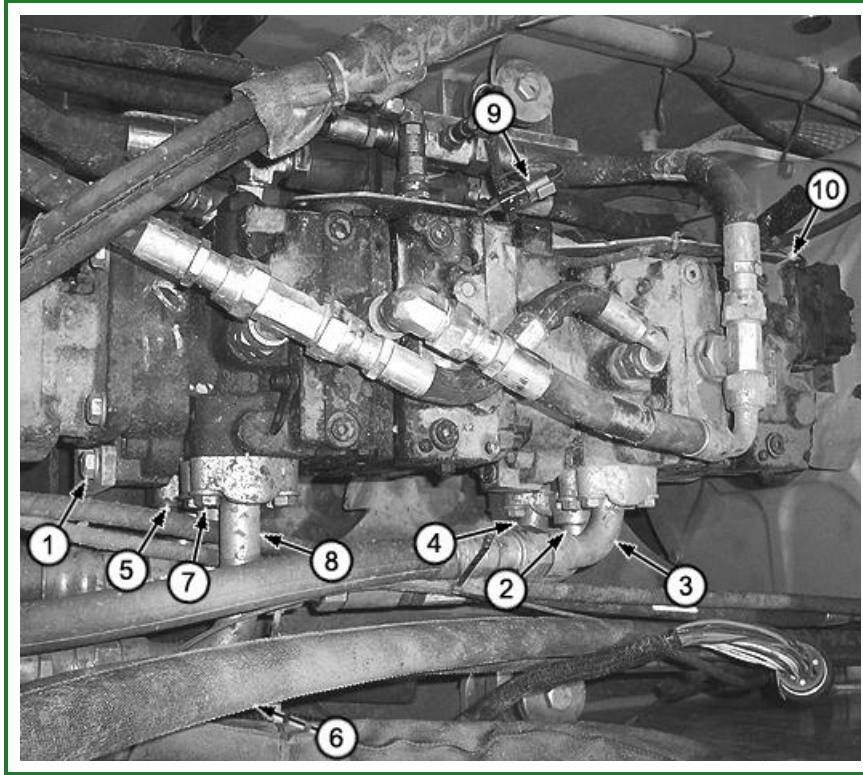

T200360A-UN: Hydrostatic Pumps

LEGEND:

- 1 - Hydrostatic Pump-to-Rear Mount Bracket Cap Screws (2 used)
- 2 - Line (Front Charge Pump-to-Rear Charge Pump Tee-Fitting)
- 3 - Line (Front Pump Reverse Outlet Port-to-R.H. Motor "B" Port)
- 4 - Line (Front Pump Forward Outlet Port-to-R.H. Motor "A" Port)
- 5 - Line (Rear Pump Forward Outlet Port-to-L.H. Motor "B" Port)
- 6 - Rear Pump Mount Bracket-to-Frame Cap Screws (4 used)
- 7 - Tee-Fitting
- 8 - Line (Rear Pump Reverse Outlet Port-to-L.H. Motor "A" Port)
- 9 - Rear Pressure Control Pilot (PCP) Wiring Connector
- 10 - Front Pressure Control Pilot (PCP) Wiring Connector

Disconnect lines (2—5, 7 and 8). Close all openings using caps and plugs.

For ease of removal and installation of pumps, lines can be tied together and pulled up and out of the way.

25. Disconnect pressure control pilot (PCP) wiring connectors (9 and 10).

26. Remove cap screws (1 and 6) and remove rear pump mounting bracket.

27.



T118456A-UN: Pump Lift Eyes

Drill and tap two 1-1/16 plugs to accommodate a 1/2 in. eye bolt.

Remove pump fittings and install eyebolts as shown.

28. Connect hydrostatic pumps to hoist using chains, DFT1063 Lifting Bracket, and DFT1130 Adapter. See DFT1063 Pump Lifting Bracket. (Group 9900.) See DFT1130 Adapter. (Group 9900.)

29.

⚠ CAUTION:

The approximate weight of the hydrostatic pump assembly is 120 kg (265 lb).

Item	Measurement	Specification
Hydrostatic Pump		
Dual Hydrostatic Pump Assembly Weight		120 kg Approximate 265 lb Approximate

Remove flywheel housing cover cap screws and pull pumps back far enough for dampener hub to clear flywheel dampener.

Place a wood block under rear pump and lower pumps to rest on frame.

Disconnect rear chain, shorten and reconnect to lift pumps out at approximate 45 degree angle.

30. Carefully remove pumps from left side of machine, flywheel housing plate first. The best clearance is achieved close to the floor, passing through the recess in console frame.

31. Remove hydraulic lines and fittings from pumps.

Tag lines and mark orientation of fittings to aid in reassembly.

32.

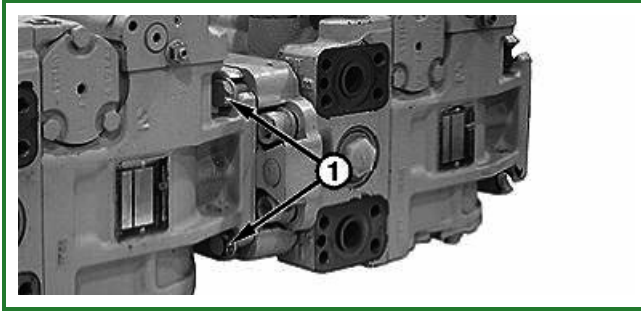

T118271B-UN: Double Pump Assembly Bolts

LEGEND:

1 - Socket Head Cap Screw (4 used)

Remove cap screws (1) joining the two pumps and separate pumps.

33.

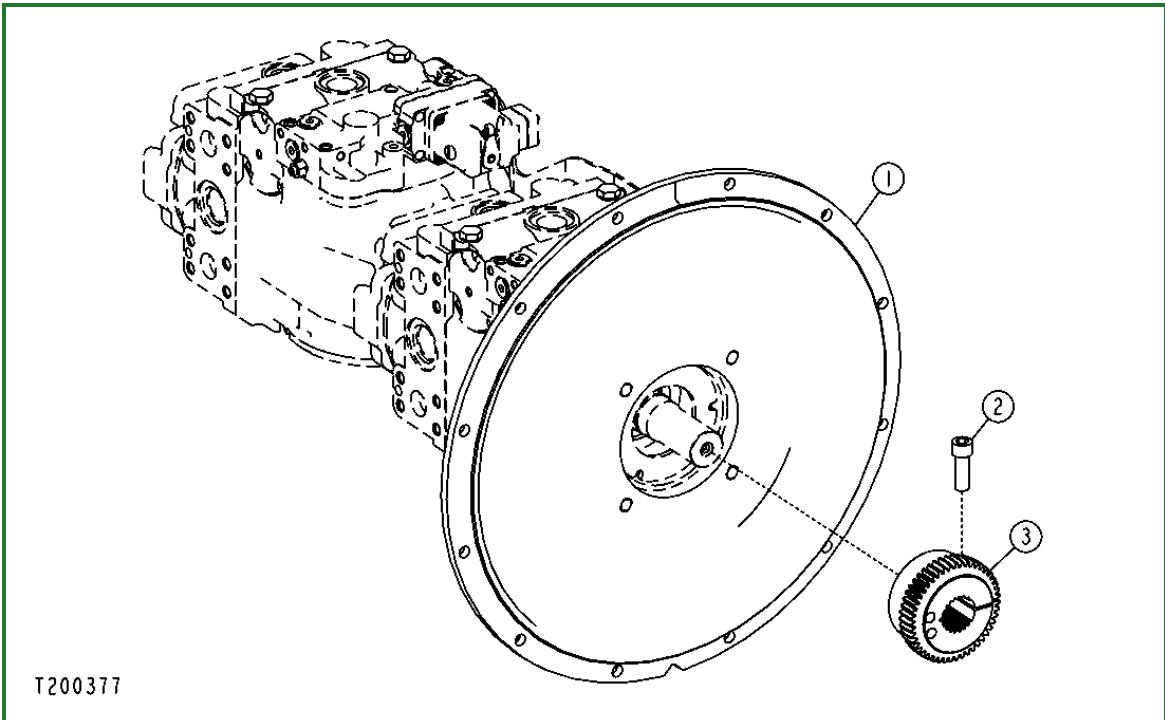

T200377-UN: Dampener Assembly

LEGEND:

1 - Flywheel Housing Plate

2 - Set Screw

3 - Dampener Hub

Remove set screw (2) and dampener hub (3) from pump drive shaft.

34. Remove four pump mounting cap screws and flywheel housing plate (1).

35. Install flywheel housing plate on pump. Tighten cap screws to specifications.

Item	Measurement	Specification
Hydrostatic Pump		
Hydrostatic Pump-to-Flywheel Housing Plate	Torque	150 N·m 115 lb-ft

36. Install dampener hub until internal snap ring contacts end of pump shaft.

37. Install set screw (2). Tighten to specification.

Item	Measurement	Specification
Hydrostatic Pump		
Dampener Hub-to-Hydrostatic Pump Shaft Set Screws	Torque	86 N·m 63 lb-ft

38.

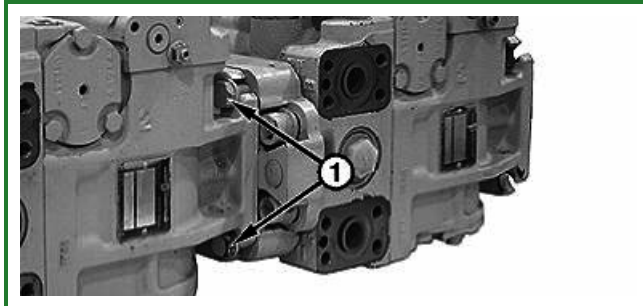

T118271B-UN: Assembly Cap Screw

LEGEND:

1 - Cap Screw (4 used)

Assemble pumps using four cap screws (1).

39. Install hydraulic lines in position as marked during removal.

40. IMPORTANT:

If dampener plate has been removed, see [Dampener Drive Remove and Install](#) . (Group 0752.) for correct assembly to flywheel.

Install hydrostatic pumps.

Adjust lifting chains as necessary when installing pumps to align dampener hub with dampener plate.

Clean threads of flywheel housing cover plate cap screws. Apply cure primer and thread lock and sealer (medium strength) to threads of cap screws and install. Tighten cap screws to specifications.

Item	Measurement	Specification
Hydrostatic Pump		
Flywheel Housing Cover Plate	Torque	57 N·m 42 lb-ft

41. Remove lift eyes from pumps and reinstall fittings.

42.

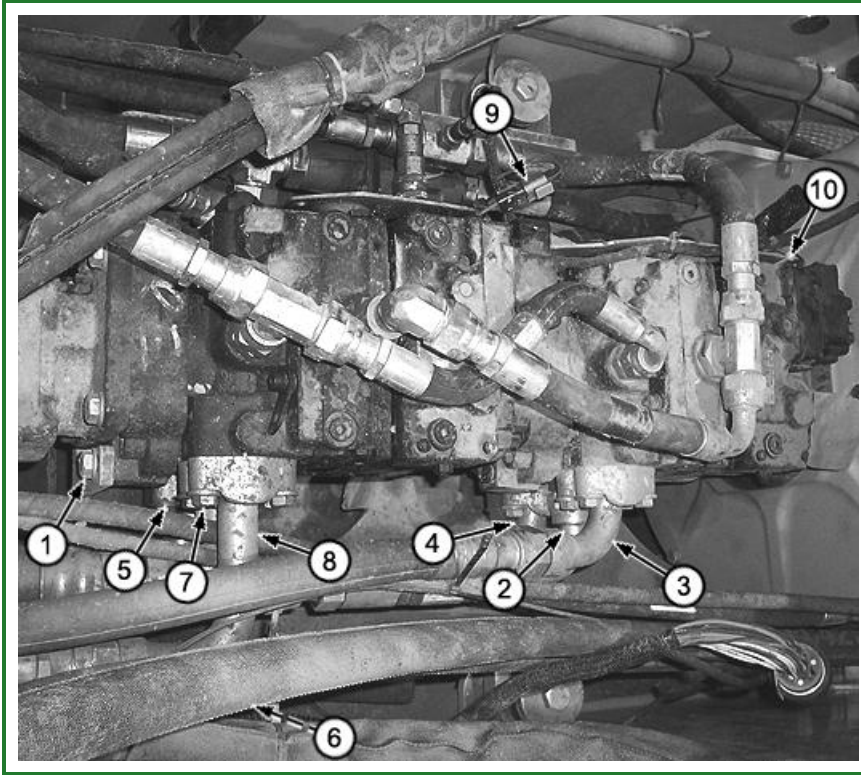

T200360A-UN: Hydrostatic Pumps

LEGEND:

- 1 - Hydrostatic Pump-to-Rear Mount Bracket Cap Screws (2 used)
- 2 - Line (Front Charge Pump-to-Rear Charge Pump Tee Fitting)
- 3 - Line (Front Pump Reverse Outlet Port-to-R.H. Motor "B" Port)
- 4 - Line (Front Pump Forward Outlet Port-to-R.H. Motor "A" Port)
- 5 - Line (Rear Pump Forward Outlet Port-to-L.H. Motor "B" Port)
- 6 - Rear Pump Mount Bracket-to-Frame Cap Screws (4 used)
- 7 - Tee Fitting
- 8 - Line (Rear Pump Reverse Outlet Port-to-L.H. Motor "A" Port)
- 9 - Rear Pressure Control Pilot (PCP) Wiring Connector
- 10 - Front Pressure Control Pilot (PCP) Wiring Connector

Install rear pump mount bracket and tighten cap screws (1 and 6).

43. Install lines (2—5, 7 and 8).

44. Connect pressure control pilot (PCP) wiring connectors (9 and 10)

45.

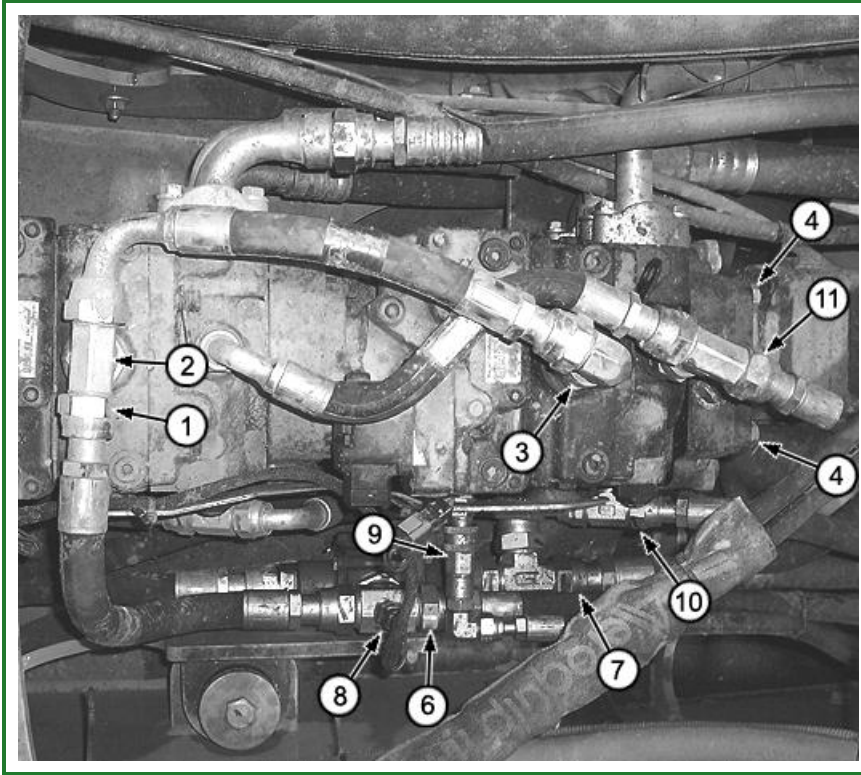

T200359A-UN: Hydrostatic Pumps

LEGEND:

- 1 - Line (Front Pump Tee Fitting-to-Cooler Bypass Valve)
- 2 - Tee Fitting (Front Pump)
- 3 - Line Fitting (Rear Pump)
- 4 - Hydraulic Pump Mounting Cap Screws (4 used)
- 5 - Not Used
- 6 - Line (Oil Cooler Bypass Valve-to-Reservoir)
- 7 - Line (Left Motor Tee Fitting-to-Oil Cooler Bypass Valve)
- 8 - Oil Cooler Bypass Valve Wire Terminal
- 9 - Line (Park Brake)
- 10 - Line (Oil Filter-to-Charge Pump)
- 11 - Line (Charge Pump-to-Oil Filter)

Install lines with fittings (1—3), (6, 7, 9 and 10).

46. Connect terminal (8).

47. Install hydraulic pump. Tighten cap screws (4) to specifications.

Item	Measurement	Specification
Hydrostatic Pump		
Hydraulic Pump Mounting Cap Screws	Torque	140 N·m 103 lb-ft

48.

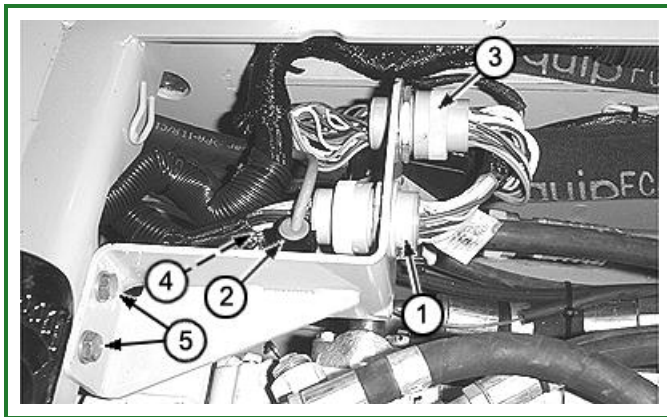

T200959A-UN: Harness Connectors

LEGEND:

- 1 - Engine Harness Connector
- 2 - Engine Harness Connector
- 3 - Transmission Harness Connector
- 4 - Heater Valve Clamp (Cab units only) (2 used)
- 5 - Bracket Cap Screw (2 used)

Connect bracket to frame and tighten cap screws (5).

49. Install connectors (1—3).

Route harnesses to original locations and install tie bands.

50. Attach heater valve to bracket and tighten clamps (4).

51. Install heater and connect heater hoses.

52. Install access plate on bottom of hydrostatic reservoir compartment.

53. Fill hydrostatic reservoir. [See Transmission and Hydraulic Oil](#) . (Operators Manual.)

Item	Measurement	Specification
Hydrostatic Pump		
Hydrostatic Reservoir Capacity		43 L Approximate 11.3 gal Approximate

54. Fill radiator with coolant. [See Fill the Cooling System](#) . (Operators Manual.)

Item	Measurement	Specification
Hydrostatic Pump		
Engine Coolant Capacity		11.3 L Approximate 3 gal Approximate

55. Turn battery disconnect switch to ON.

56. Perform hydrostatic pump start-up procedure. [See Hydrostatic Pump and Motor Initial Start-Up Procedure](#) . (Group 9026-25.)

57. Lower seat and secure floor plate.

58. Install tool box (if equipped), knee pads and armrests.

59. Install floor access plate and mat.

60. Calibrate transmission controller. [See Transmission Control Unit \(TCU\) Calibration](#) . (Group 9015-20.)

Go to [Section_03:Group_0300](#)

CED, TX03399, 5046-19-20091204

Hydrostatic Pump Remove and Install



T116758B-UN: Seat Base Cap Screws

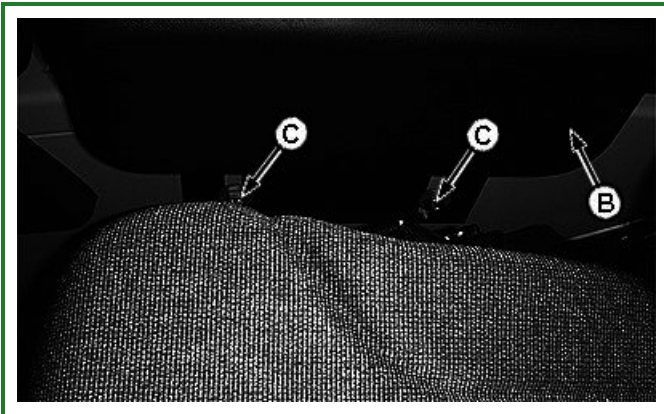

T116757B-UN: Seat Armrest Cap Screws

LEGEND:

- A - Cap Screws Around Seat Box Bottom (4 used)
- B - Armrest
- C - Shoulder Cap Screws (2 used)
- E - Knee Pad

1.

⚠ CAUTION:

Prevent possible injury from unexpected track movement. Raise the machine off the ground and support with blocks. Tracks MUST be free to rotate in either direction to perform Hydrostatic Pump Initial Startup Procedure and Pump Displacement Control Valve Neutral (Null) Adjustment.

Raise machine off the ground and support with blocks. Lower blade to ground. Tracks MUST be free to rotate in either direction.

2. Turn battery disconnect switch to OFF.

3.

NOTE:

The approximate capacity of hydrostatic reservoir is 43 L (11.3 gal).

Remove access plate from bottom of hydrostatic reservoir compartment and drain reservoir.

4. **NOTE:**

The approximate capacity of engine coolant is 11.3 L (3 gal).

If equipped with heater, drain engine coolant.

5. Remove floor mat and floor access plate.
6. For machines with toolbox, pull out drawer and remove cap screw holding toolbox in place. Remove toolbox from machine.
7. Remove four cap screws (A) from around seat box bottom.
8. Remove shoulder cap screws (C) from seat box under armrest (B) on both sides of seat.
9. Remove two cap screws from knee pad (E) on both sides of seat.
10. **IMPORTANT:**
Observe control levers as seat is being raised or lowered for possible interference.

Loosen jam nut on hydraulic control lever tee handle and index handle 90° to provide clearance for seat when tilting.
11. On units equipped with rear screen or cab, tilt back of seat forward.

12.

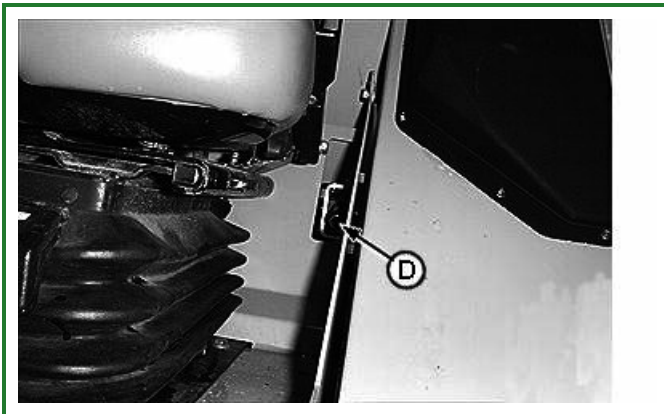

T200435A-UN: Jack Screw

LEGEND:

D - Jack Screw

Tilt seat up as far as possible with jack screw (D) located in left rear corner of seat box.

13.

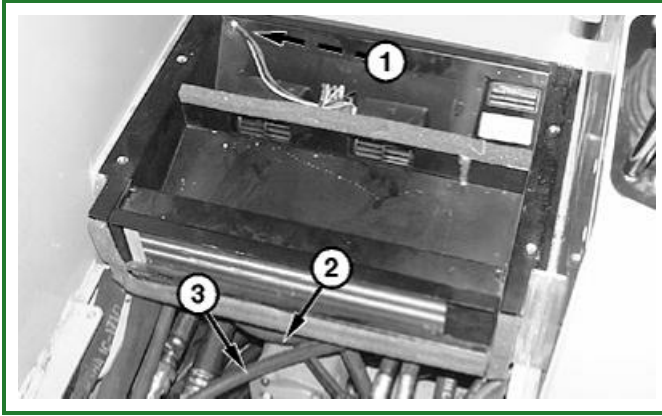
**T118838B-UN: Heater****LEGEND:**

- 1 - Blower Harness Connector
- 2 - Heater Hose
- 3 - Heater Hose

Disconnect blower harness connector (1) and heater hoses (2 and 3).

14. Remove heater assembly.

15.

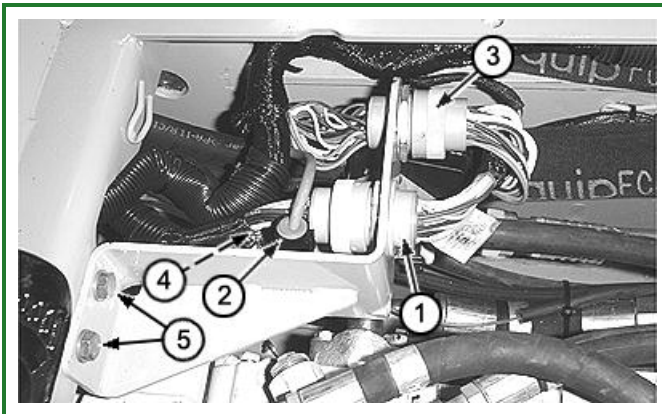
**T200959A-UN: Harness Connections****LEGEND:**

- 1 - Engine Harness Connector
- 2 - Engine Harness Connector
- 3 - Transmission Harness Connector
- 4 - Heater Valve Clamp (Cab units only) (2 used)
- 5 - Bracket Cap Screw (2 used)

Disconnect engine harness connectors (1 and 2) and transmission harness connector (3).

16. Disconnect engine harness connector (1) from bracket.

17. Loosen hose clamps (4) from heater valve and disconnect heater valve from bracket. (Do not disconnect hoses from heater valve).

18. Remove cap screws (5) from bracket and move bracket, wiring and hoses off to side.

19.

⚠ CAUTION:

To avoid injury from escaping fluid under pressure, stop engine and relieve the pressure in the system before disconnecting or connecting hydraulic or other lines. Tighten all connections before applying pressure.

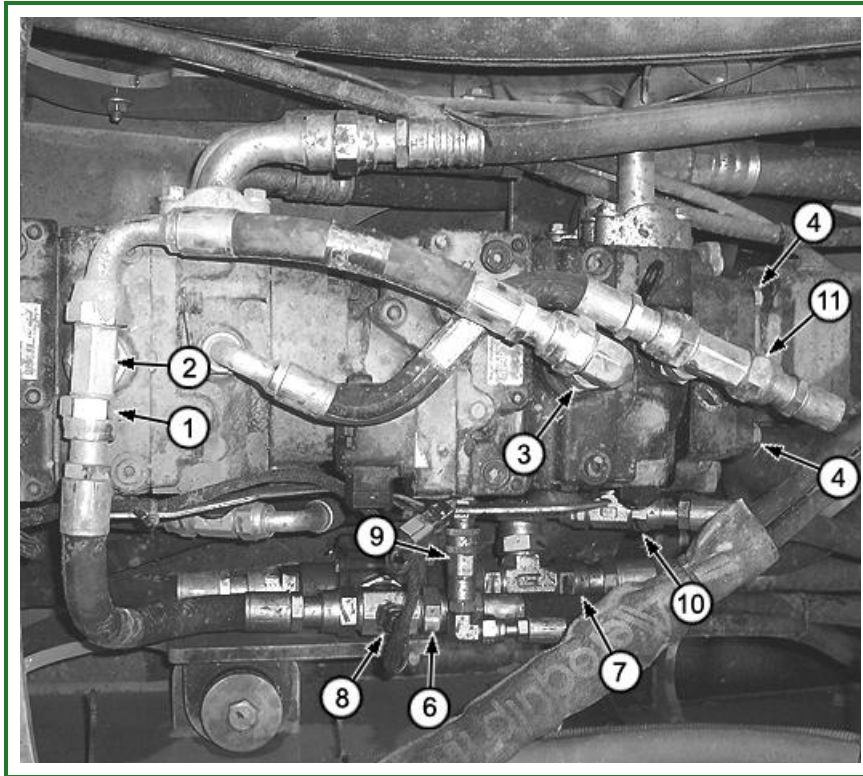

T200359A-UN: Hydrostatic Pumps

LEGEND:

- 1 - Line (Front Pump Tee Fitting-to-Cooler Bypass Valve)
- 2 - Tee Fitting (Front Pump)
- 3 - Line Fitting (Rear Pump)
- 4 - Hydraulic Pump Mounting Cap Screws (4 used)
- 5 - Not Used
- 6 - Line (Oil Cooler Bypass Valve-to-Reservoir)
- 7 - Line (Left Motor Tee Fitting-to-Oil Cooler Bypass Valve)
- 8 - Oil Cooler Bypass Valve Wire Terminal
- 9 - Line (Park Brake)
- 10 - Line (Oil Filter-to-Charge Pump)
- 11 - Line (Charge Pump-to-Oil Filter)

Disconnect line (1). Close all openings using caps and plugs.

- 20. Disconnect fittings (2 and 3) and remove line.
- 21. Disconnect lines (6, 7, 9, and 10).
- 22. Disconnect wire terminal (8).
- 23. Remove cap screws (4) from hydraulic pump and remove pump. Set pump aside.

24.

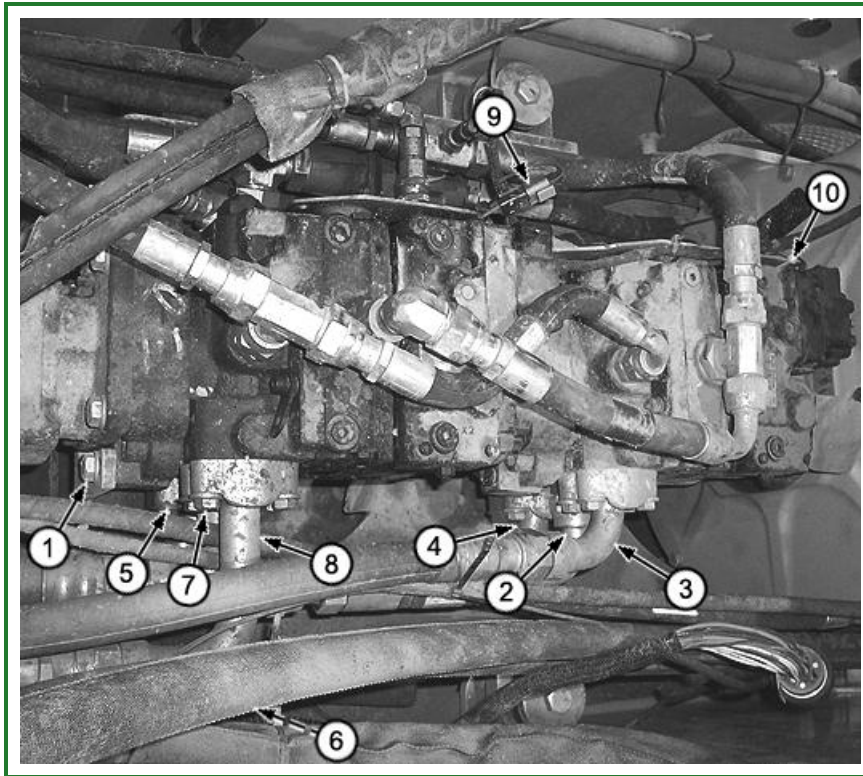

T200360A-UN: Hydrostatic Pumps

LEGEND:

- 1 - Hydrostatic Pump-to-Rear Mount Bracket Cap Screws (2 used)
- 2 - Line (Front Charge Pump-to-Rear Charge Pump Tee-Fitting)
- 3 - Line (Front Pump Reverse Outlet Port-to-R.H. Motor "B" Port)
- 4 - Line (Front Pump Forward Outlet Port-to-R.H. Motor "A" Port)
- 5 - Line (Rear Pump Forward Outlet Port-to-L.H. Motor "B" Port)
- 6 - Rear Pump Mount Bracket-to-Frame Cap Screws (4 used)
- 7 - Tee-Fitting
- 8 - Line (Rear Pump Reverse Outlet Port-to-L.H. Motor "A" Port)
- 9 - Rear Pressure Control Pilot (PCP) Wiring Connector
- 10 - Front Pressure Control Pilot (PCP) Wiring Connector

Disconnect lines (2—5, 7 and 8). Close all openings using caps and plugs.

For ease of removal and installation of pumps, lines can be tied together and pulled up and out of the way.

25. Disconnect pressure control pilot (PCP) wiring connectors (9 and 10).

26. Remove cap screws (1 and 6) and remove rear pump mounting bracket.

27.



T118456A-UN: Pump Lift Eyes

Drill and tap two 1-1/16 plugs to accommodate a 1/2 in. eye bolt.

Remove pump fittings and install eyebolts as shown.

28. Connect hydrostatic pumps to hoist using chains, DFT1063 Lifting Bracket, and DFT1130 Adapter. See DFT1063 Pump Lifting Bracket. (Group 9900.) See DFT1130 Adapter. (Group 9900.)

29.

⚠ CAUTION:

The approximate weight of the hydrostatic pump assembly is 120 kg (265 lb).

Item	Measurement	Specification
Hydrostatic Pump		
Dual Hydrostatic Pump Assembly Weight		120 kg Approximate 265 lb Approximate

Remove flywheel housing cover cap screws and pull pumps back far enough for dampener hub to clear flywheel dampener.

Place a wood block under rear pump and lower pumps to rest on frame.

Disconnect rear chain, shorten and reconnect to lift pumps out at approximate 45 degree angle.

30. Carefully remove pumps from left side of machine, flywheel housing plate first. The best clearance is achieved close to the floor, passing through the recess in console frame.
31. Remove hydraulic lines and fittings from pumps.

Tag lines and mark orientation of fittings to aid in reassembly.

32.

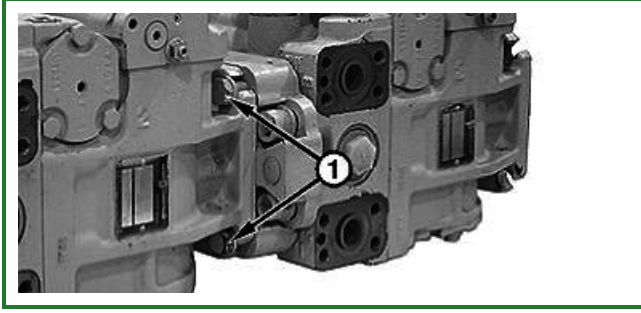

T118271B-UN: Double Pump Assembly Bolts

LEGEND:

1 - Socket Head Cap Screw (4 used)

Remove cap screws (1) joining the two pumps and separate pumps.

33.

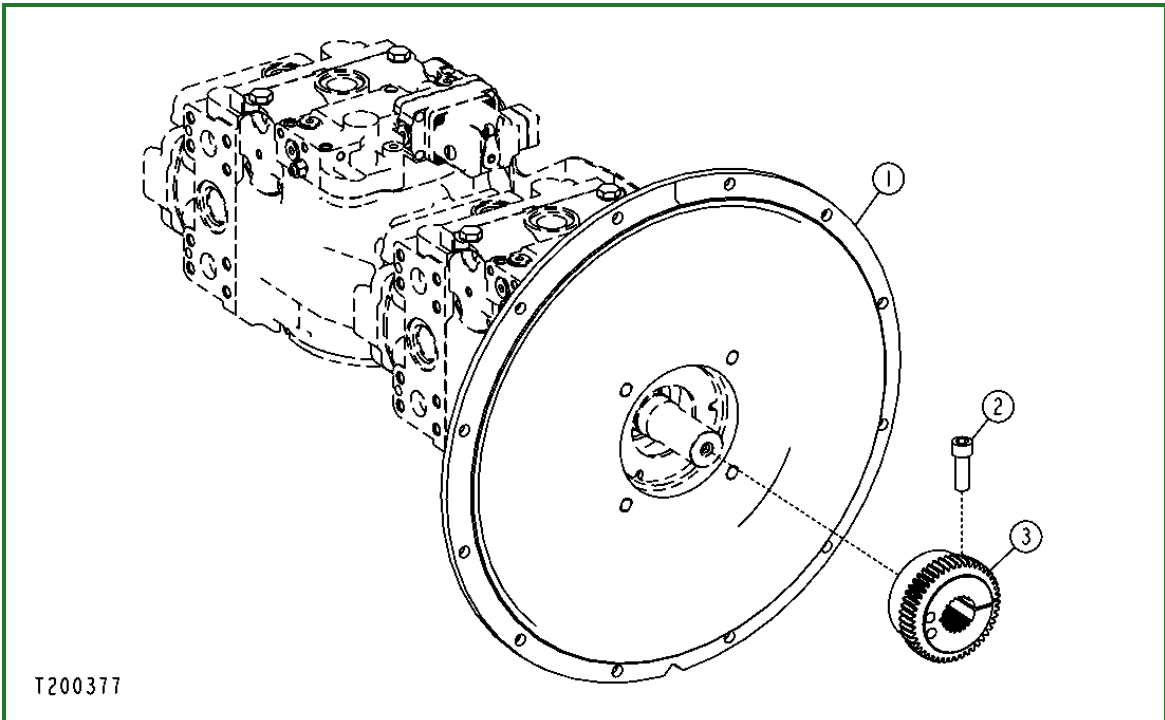

T200377-UN: Dampener Assembly

LEGEND:

1 - Flywheel Housing Plate

2 - Set Screw

3 - Dampener Hub

Remove set screw (2) and dampener hub (3) from pump drive shaft.

34. Remove four pump mounting cap screws and flywheel housing plate (1).

35. Install flywheel housing plate on pump. Tighten cap screws to specifications.

Item	Measurement	Specification
Hydrostatic Pump		
Hydrostatic Pump-to-Flywheel Housing Plate	Torque	150 N·m 115 lb-ft

36. Install dampener hub until internal snap ring contacts end of pump shaft.

37. Install set screw (2). Tighten to specification.

Item	Measurement	Specification
Hydrostatic Pump		
Dampener Hub-to-Hydrostatic Pump Shaft Set Screws	Torque	86 N·m 63 lb-ft

38.

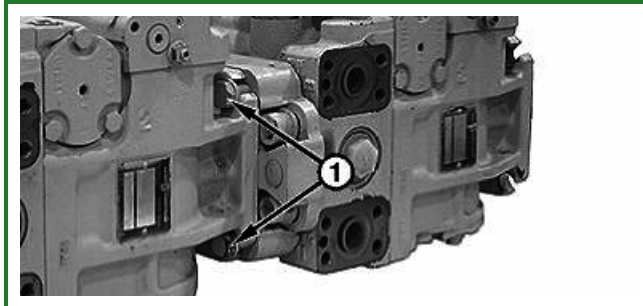

T118271B-UN: Assembly Cap Screw

LEGEND:

1 - Cap Screw (4 used)

Assemble pumps using four cap screws (1).

39. Install hydraulic lines in position as marked during removal.

40. IMPORTANT:

If dampener plate has been removed, see [Dampener Drive Remove and Install](#) . (Group 0752.) for correct assembly to flywheel.

Install hydrostatic pumps.

Adjust lifting chains as necessary when installing pumps to align dampener hub with dampener plate.

Clean threads of flywheel housing cover plate cap screws. Apply cure primer and thread lock and sealer (medium strength) to threads of cap screws and install. Tighten cap screws to specifications.

Item	Measurement	Specification
Hydrostatic Pump		
Flywheel Housing Cover Plate	Torque	57 N·m 42 lb-ft

41. Remove lift eyes from pumps and reinstall fittings.

42.

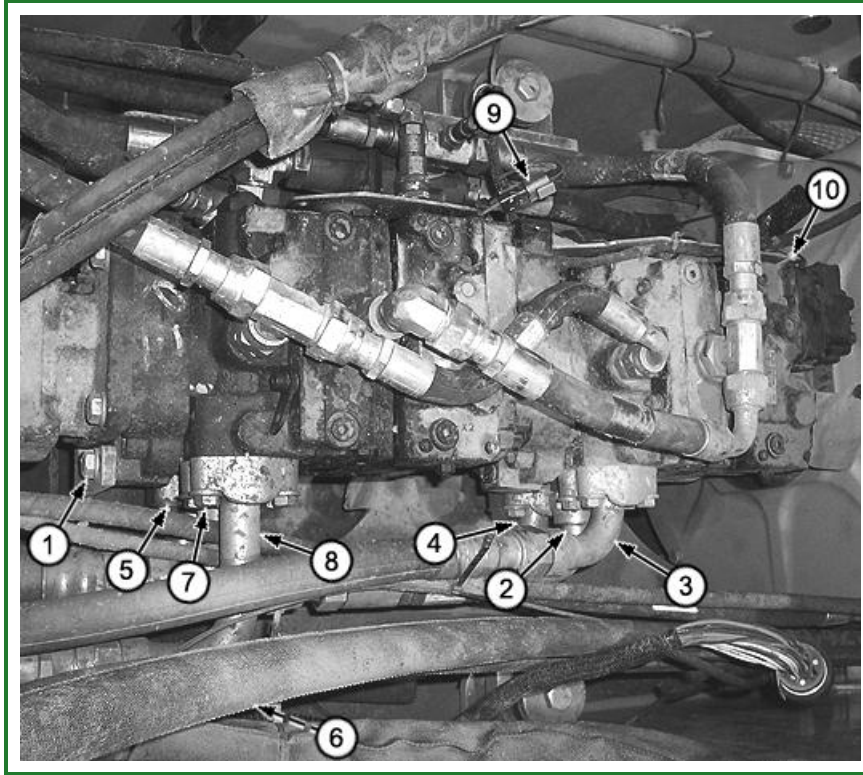
**T200360A-UN: Hydrostatic Pumps****LEGEND:**

- 1 - Hydrostatic Pump-to-Rear Mount Bracket Cap Screws (2 used)
- 2 - Line (Front Charge Pump-to-Rear Charge Pump Tee Fitting)
- 3 - Line (Front Pump Reverse Outlet Port-to-R.H. Motor "B" Port)
- 4 - Line (Front Pump Forward Outlet Port-to-R.H. Motor "A" Port)
- 5 - Line (Rear Pump Forward Outlet Port-to-L.H. Motor "B" Port)
- 6 - Rear Pump Mount Bracket-to-Frame Cap Screws (4 used)
- 7 - Tee Fitting
- 8 - Line (Rear Pump Reverse Outlet Port-to-L.H. Motor "A" Port)
- 9 - Rear Pressure Control Pilot (PCP) Wiring Connector
- 10 - Front Pressure Control Pilot (PCP) Wiring Connector

Install rear pump mount bracket and tighten cap screws (1 and 6).

43. Install lines (2—5, 7 and 8).

44. Connect pressure control pilot (PCP) wiring connectors (9 and 10)

45.

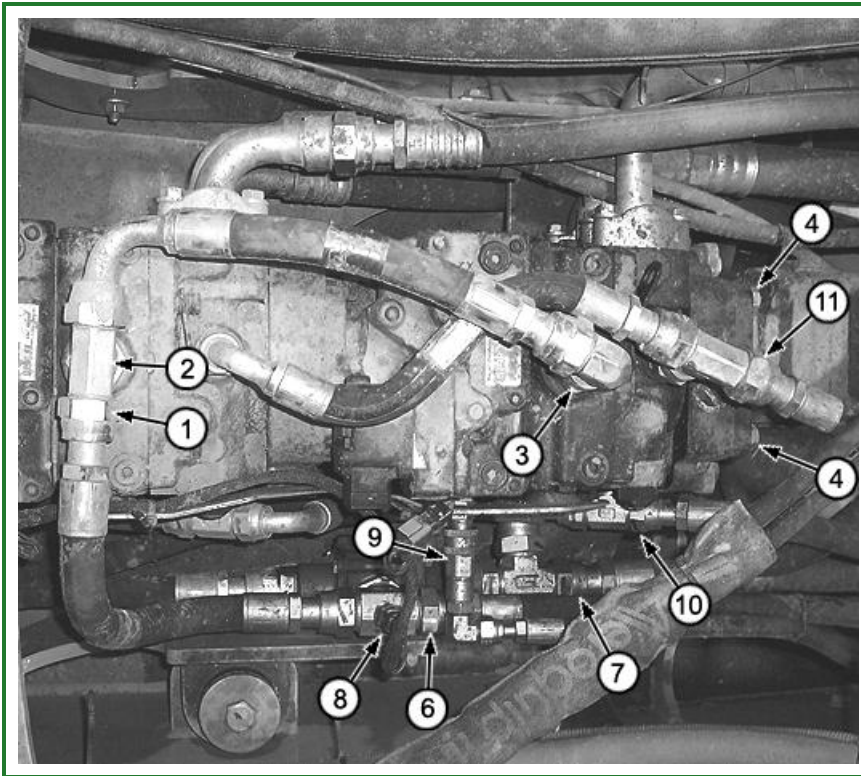
**T200359A-UN: Hydrostatic Pumps****LEGEND:**

- 1 - Line (Front Pump Tee Fitting-to-Cooler Bypass Valve)
- 2 - Tee Fitting (Front Pump)
- 3 - Line Fitting (Rear Pump)
- 4 - Hydraulic Pump Mounting Cap Screws (4 used)
- 5 - Not Used
- 6 - Line (Oil Cooler Bypass Valve-to-Reservoir)
- 7 - Line (Left Motor Tee Fitting-to-Oil Cooler Bypass Valve)
- 8 - Oil Cooler Bypass Valve Wire Terminal
- 9 - Line (Park Brake)
- 10 - Line (Oil Filter-to-Charge Pump)
- 11 - Line (Charge Pump-to-Oil Filter)

Install lines with fittings (1—3), (6, 7, 9 and 10).

46. Connect terminal (8).

47. Install hydraulic pump. Tighten cap screws (4) to specifications.

Item	Measurement	Specification
Hydrostatic Pump		
Hydraulic Pump Mounting Cap Screws	Torque	140 N·m 103 lb-ft

48.

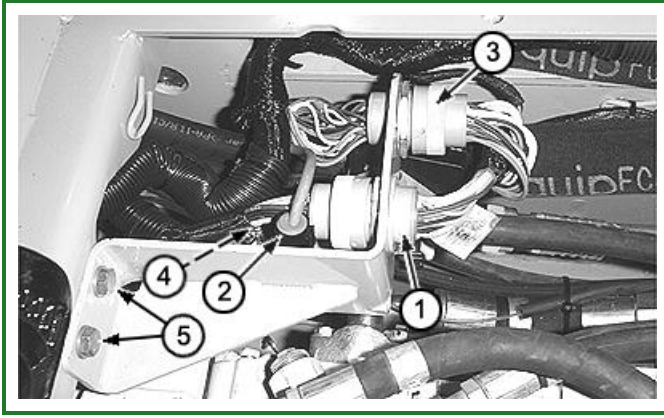
**T200959A-UN: Harness Connectors****LEGEND:**

- 1 - Engine Harness Connector
- 2 - Engine Harness Connector
- 3 - Transmission Harness Connector
- 4 - Heater Valve Clamp (Cab units only) (2 used)
- 5 - Bracket Cap Screw (2 used)

Connect bracket to frame and tighten cap screws (5).

49. Install connectors (1—3).

Route harnesses to original locations and install tie bands.

50. Attach heater valve to bracket and tighten clamps (4).

51. Install heater and connect heater hoses.

52. Install access plate on bottom of hydrostatic reservoir compartment.

53. Fill hydrostatic reservoir. [See Transmission and Hydraulic Oil](#) . (Operators Manual.)

Item	Measurement	Specification
Hydrostatic Pump		
Hydrostatic Reservoir Capacity		43 L Approximate 11.3 gal Approximate

54. Fill radiator with coolant. [See Fill the Cooling System](#) . (Operators Manual.)

Item	Measurement	Specification
Hydrostatic Pump		
Engine Coolant Capacity		11.3 L Approximate 3 gal Approximate

55. Turn battery disconnect switch to ON.

56. Perform hydrostatic pump start-up procedure. [See Hydrostatic Pump and Motor Initial Start-Up Procedure](#) . (Group 9026-25.)

57. Lower seat and secure floor plate.

58. Install tool box (if equipped), knee pads and armrests.

59. Install floor access plate and mat.

60. Calibrate transmission controller. [See Transmission Control Unit \(TCU\) Calibration](#) . (Group 9015-20.)

Go to [Section_03:Group_0300](#)

CED,TX03399,5046-19-20091204

Hydrostatic Motor Remove and Install

1. Lower all equipment to ground.
2. Stop engine. Operate all hydraulic controls to release pressure in hydraulic system.
3. Turn battery disconnect switch to OFF.

4. **NOTE:**

Reservoir capacity is approximately 43 L (11.3 gal).

Drain reservoir or apply a vacuum to reservoir.

5. Remove rear access cover or rear mounted optional equipment from rear of machine.
6. Remove left or right floor access plate to disconnect lines.

7. **⚠ CAUTION:**

To avoid injury from escaping fluid under pressure, stop engine and relieve the pressure in the system before disconnecting or connecting hydraulic or other lines. Tighten all connections before applying pressure.

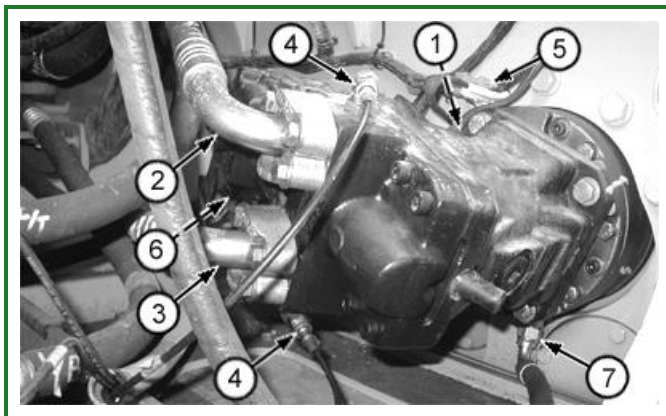

T199187A-UN: Hydrostatic Motor Removal

LEGEND:

- 1 - Case Drain Hose
- 2 - Forward Direction Hose
- 3 - Reverse Direction Hose
- 4 - Diagnostic Hose
- 5 - Motor Speed Sensor Connector
- 6 - Motor Shift Solenoid Connector
- 7 - Park Brake Hose

Tag and mark hose locations to aid in assembly.

8. Disconnect case drain hose (1), diagnostic pressure hoses (4), and park brake hose (7).

9. Disconnect forward and reverse hoses (2 and 3).
10. Close all openings using caps and plugs.
11. Disconnect wire connectors from motor shift solenoid (6) and motor speed sensor (5).

12.

⚠ CAUTION:

The approximate weight of hydrostatic motor is 38.5 kg (85 lb).

NOTE:

DFT1137 Hydrostatic Motor Removal and Installation Tool will need to be updated. A threaded hole is added to remove right side motor. See DFT1137 Hydrostatic Motor Removal and Installation Tool . (Group 9900.)

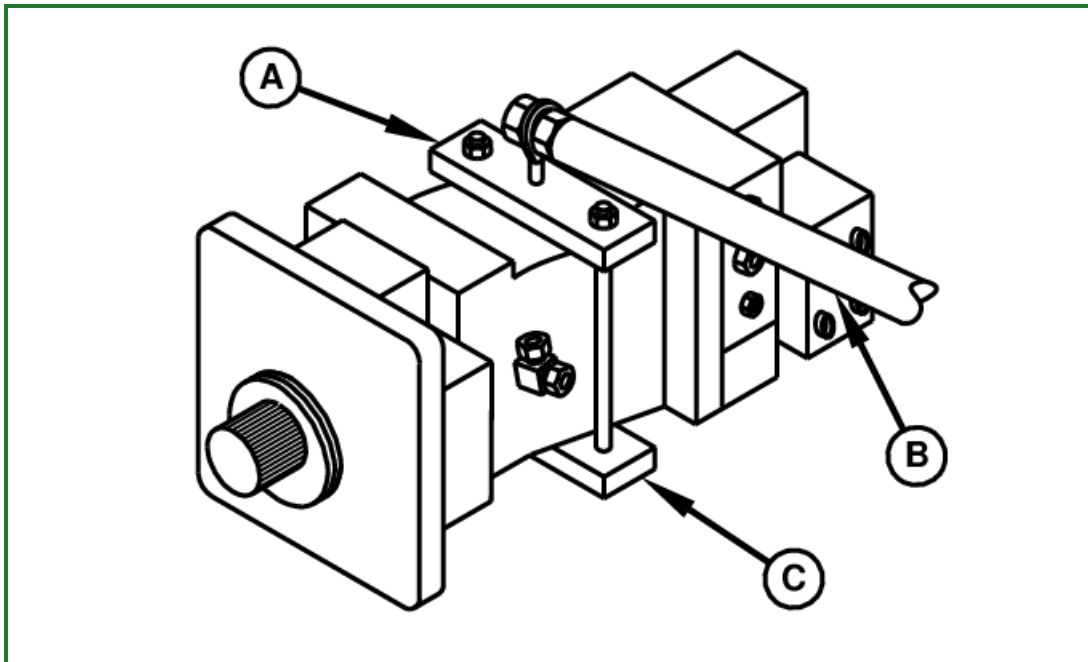
**TX1074259-UN: Hydrostatic Motor Removal****LEGEND:**

- A - DFT1137 Hydrostatic Motor Removal and Installation Tool
- B - DFT1132 Hydrostatic Motor Removal and Installation Tool
- C - DFT1137 Hydrostatic Motor Removal and Installation Tool

Attach DFT1132 Hydrostatic Motor and Hydraulic Pump Removal and Installation Tool to hoist with sling. See DFT1132 Hydrostatic Motor Removal and Installation Tool . (Group 099.)

13. Attach DFT1137 Hydrostatic Motor Removal and Installation Tool to motor. See DFT1137 Hydrostatic Motor Removal and Installation Tool . (Group 9900.)
14. Attach DFT1132 to eyebolt in DFT1137.
15. Remove four cap screws and washers from motor-to-mounting flange.

16. Carefully pry motor away from mounting flange.
17. Remove through hole in rear of machine.
18. Clean threads of mounting studs and nuts.
19. Repair or replace motor.
20. Apply petroleum jelly to new O-ring and install on transmission motor flange.
21. Guide hydrostatic motor through frame opening.
22. Position motor on studs and align splines in coupler and slide motor into position.
23. Apply PM37509 Cure Primer and PM38656 Thread Lock and Sealer (high strength) to threads of nuts and tighten to specification.

Item	Measurement	Specification
Hydrostatic Motor Mounting Cap Screws	Torque	130 N·m 95 lb-ft

24. Remove hydrostatic motor removal and installation tools.
25. Connect hydrostatic lines and wiring connector.
26. Fill reservoir if drained. [See Transmission and Hydraulic Oil](#) . (Operators Manual.)
27. Turn battery disconnect switch to ON.
28. [Perform Hydrostatic Pump and Motor Initial Start-Up Procedure](#) . (9026-25.)
29. [See Transmission Control Unit \(TCU\) Calibration](#) . (9015-20)
30. Install rear access plate or rear mounted optional equipment.
31. Replace bottom access plates if removed.

Go to [Section_03:Group_0300](#)

TE14778,0000021-19-20131024

Transmission Control Lever (TCL) Remove and Install

1. Turn battery disconnect switch to the OFF position.

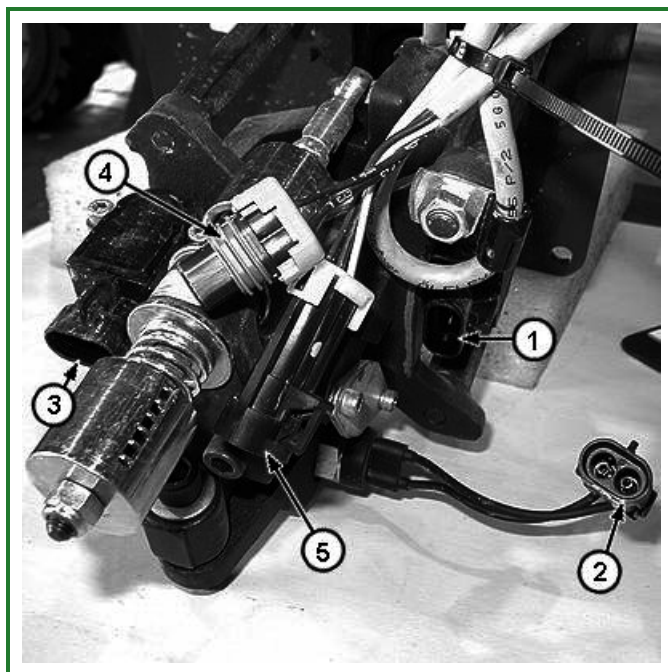

T199271A-UN: Transmission Control Lever Remove and Install

LEGEND:

- 1 - Steer Sensor
- 2 - Neutral Start Switch
- 3 - FNR Sensor
- 4 - Harness to Horn Switch
- 5 - Harness to Transmission Switch

2.

NOTE:

Mark electrical connectors to aid in assembly.

Disconnect rotary sensors (1 and 3) and neutral start switch (2).

3. Disconnect harness connectors (4 and 5) to transmission speed control switch and horn button.

4.

**T199276A-UN: Transmission Control Lever (TCL)****LEGEND:**

1 - Hex Flange Screw

Remove four hex flange screws and transmission control lever (TCL) assembly.

5. Install transmission control lever (TCL) assembly using four hex flange screws.
6. Connect rotary sensors (1 and 3) and neutral start switch (2).
7. Turn battery disconnect switch to the ON position.
8. Adjust transmission control lever (TCL). [See Transmission Control Lever \(TCL\) Adjustment](#) . (Group 9015-20.)
9. Recalibrate transmission controller. [See Transmission Control Unit \(TCU\) Calibration](#). (Group 9015-20.)

Go to [Section_03:Group_0315](#)

CED,TX03543,2276-19-19990909

Transmission Control Lever (TCL) Remove and Install

1. Turn battery disconnect switch to the OFF position.

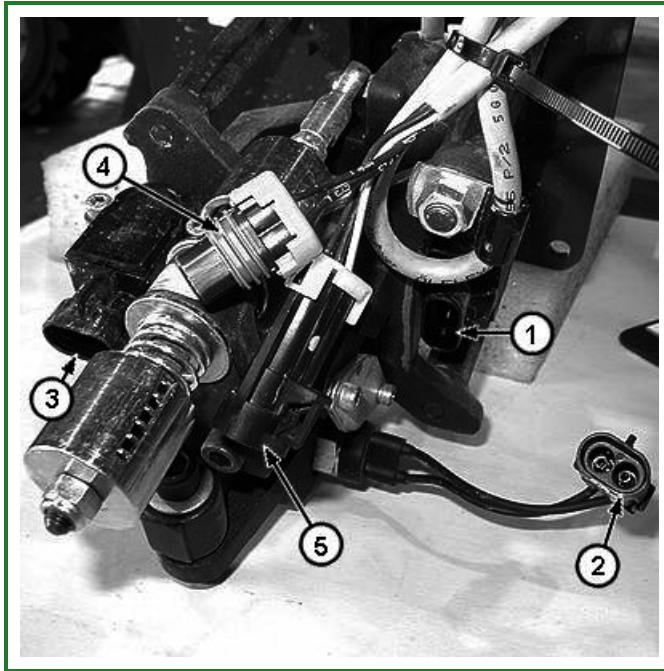

T199271A-UN: Transmission Control Lever Remove and Install

LEGEND:

- 1 - Steer Sensor
- 2 - Neutral Start Switch
- 3 - FNR Sensor
- 4 - Harness to Horn Switch
- 5 - Harness to Transmission Switch

- 2.

NOTE:

Mark electrical connectors to aid in assembly.

Disconnect rotary sensors (1 and 3) and neutral start switch (2).

3. Disconnect harness connectors (4 and 5) to transmission speed control switch and horn button.

4.

**T199276A-UN: Transmission Control Lever (TCL)****LEGEND:**

1 - Hex Flange Screw

Remove four hex flange screws and transmission control lever (TCL) assembly.

5. Install transmission control lever (TCL) assembly using four hex flange screws.
6. Connect rotary sensors (1 and 3) and neutral start switch (2).
7. Turn battery disconnect switch to the ON position.
8. Adjust transmission control lever (TCL). [See Transmission Control Lever \(TCL\) Adjustment](#) . (Group 9015-20.)
9. Recalibrate transmission controller. [See Transmission Control Unit \(TCU\) Calibration](#). (Group 9015-20.)

Go to [Section_03:Group_0315](#)

CED,TX03543,2276-19-19990909

Transmission Control Lever (TCL) Disassemble and Assemble (S.N. —130885)

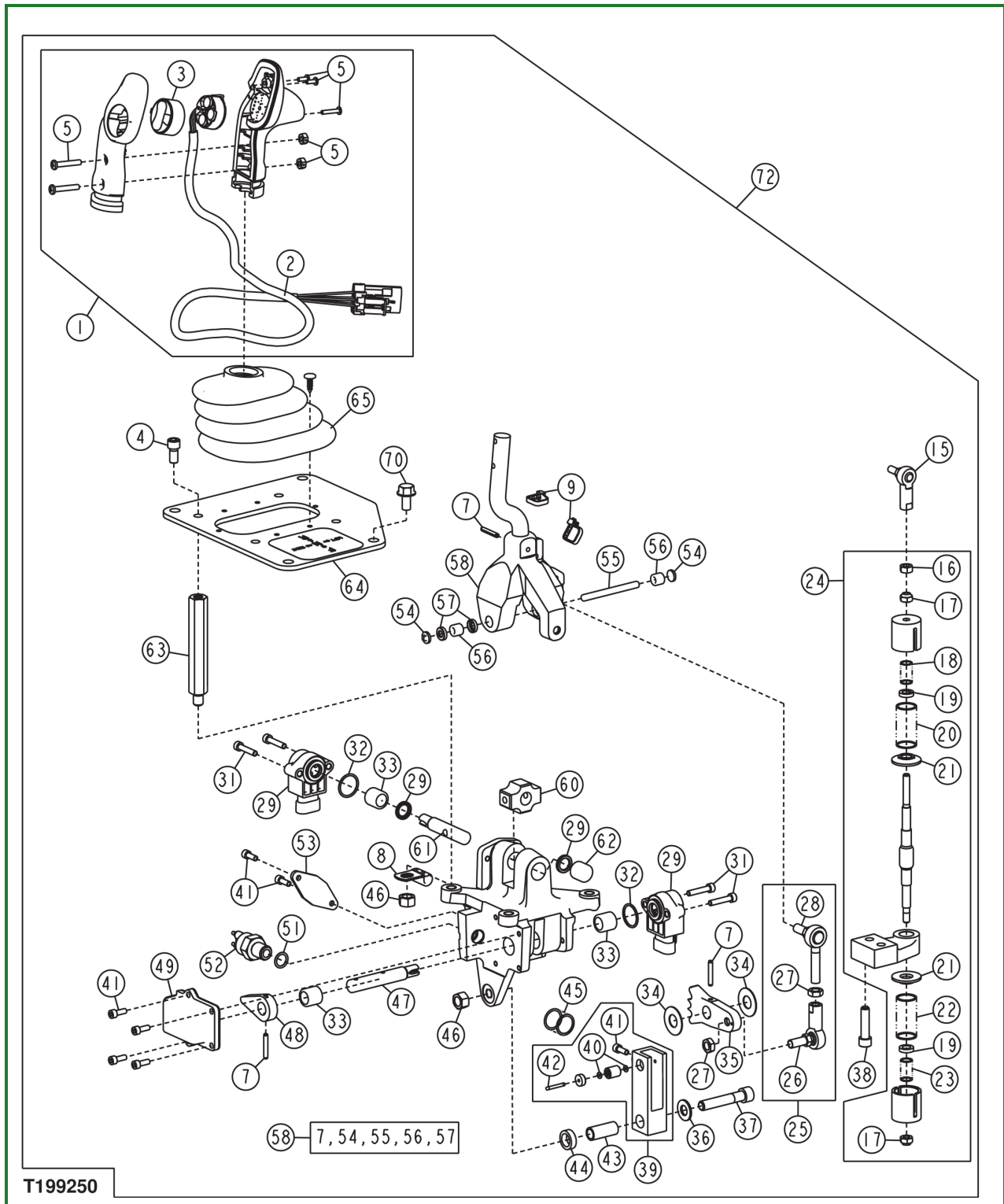

T199250-UN: Transmission Control Lever (TCL)

LEGEND:

- 1 - Transmission Control Lever (TCL)
- 2 - (TCL) Harness, Switch and Cover
- 3 - Switch Cover
- 4 - Cap Screw (4 used)
- 5 - Screw kit For Handle
- 6 - Not Used
- 7 - Spring Pin (3 used)
- 8 - Cable Clamp

- 9 - Tie Band
- 10 - Not Used
- 11 - Not Used
- 12 - Not Used
- 13 - Not Used
- 14 - Not Used
- 15 - Ball Joint
- 16 - Nut
- 17 - Nut (2 used)
- 18 - Spring
- 19 - Spacer (2 used)
- 20 - Spring
- 21 - Stepped Washer (2 used)
- 22 - Spring
- 23 - Spring
- 24 - Spring Pack Assembly
- 25 - Linkage
- 26 - Ball Joint
- 27 - Nut (2 used)
- 28 - Ball Joint
- 29 - Rotary Sensor Kit
- 30 - Not Used
- 31 - Cap Screw (2 used)
- 32 - O-Ring
- 33 - Bearing (3 used)
- 34 - Washer (2 used)
- 35 - Plate
- 36 - Washer
- 37 - Socket Head Screw
- 38 - Cap Screw (2 used)
- 39 - Detent Lever Assembly
- 40 - O-Ring (2 used)
- 41 - Cap Screw (6 used)
- 42 - Socket Head Cap Screw
- 43 - Spacer
- 44 - Spacer
- 45 - Spring
- 46 - Nut (2 used)
- 47 - Detent Shaft
- 48 - Neutral Cam
- 49 - Cam Cover
- 50 - SLC Body
- 51 - O-Ring
- 52 - Neutral Start Switch
- 53 - Spring Plate
- 54 - Seal Plug (2 used)
- 55 - Shaft
- 56 - Needle Bearing (2 used)

- 57 - Lip Seal (2 used)
- 58 - Bracket Assembly
- 59 - Lip Seal (2 used)
- 60 - Bearing Block
- 61 - Shaft
- 62 - Needle Bearing
- 63 - Mounting Post (4 used) Longer Threaded Post Shown
- 64 - Mounting Plate And FNR Label
- 65 - Boot Assembly
- 66 - Not Used
- 67 - Not Used
- 68 - Not Used
- 69 - Not Used
- 70 - Screw (4 used)
- 71 - Not Used
- 72 - Transmission Control Lever (TCL) Assembly

1.



T199273A-UN: Transmission Control Lever (TCL)

Remove transmission control lever (TCL) from side console. [See Transmission Control Lever \(TCL\) Remove and Install . \(Group 0315.\)](#)

2.

**T124638B-UN: Transmission Control Lever (TCL)****LEGEND:**

- 1 - Tie Bands
- 2 - Identification Marks
- 3 - Clamp

Separate boot from plate using a screwdriver.

- Remove tie bands (1).
- Put identification marks (2) on both sides of wire lead to aid in assembly.
- Remove clamp (3) from wire lead.

**T124645B-UN: SLC Assembly With Speed In Grip Shown****LEGEND:**

- 1 - Screw (2 used)
- 2 - Screw
- 3 - Screw with nut (2 used)

Remove screws (1, 2 and 3) and boot from SLC.



T124646B-UN: Speed In Grip Switch

LEGEND:

- 1 - Grip
- 2 - Switch
- 3 - Boot

Split grip halves (1) to remove switch (2). Boot (3) on switch can be replaced, if necessary.

3. Loosen lock nut (1).

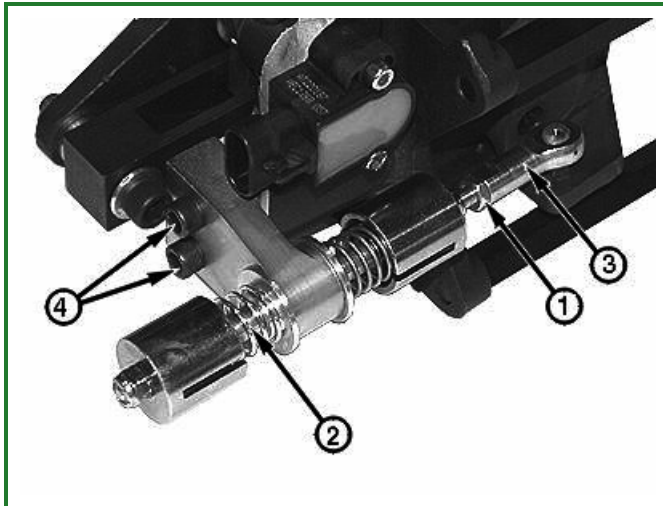

T119639B-UN: SLC Steer Shaft Removal

LEGEND:

- 1 - Lock Nut
- 2 - Steer Shaft
- 3 - Rod End
- 4 - Socket Head Cap Screw (2 used)

4. Remove steer shaft (2) from rod end (3).

5. Remove two socket head cap screws (4) and remove steer shaft assembly from body.

6. Remove rod end lock nut (8).

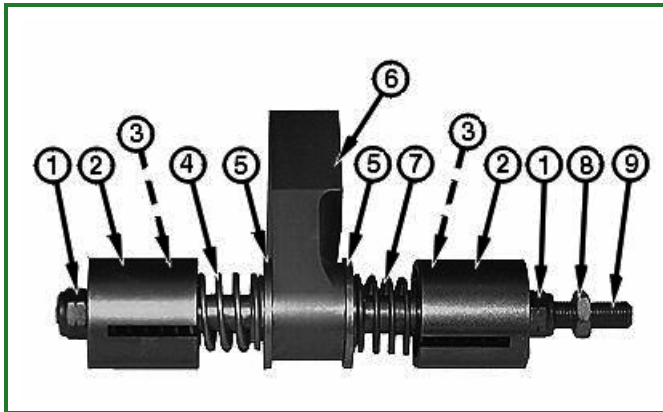

T119641B-UN: SLC Steer Shaft

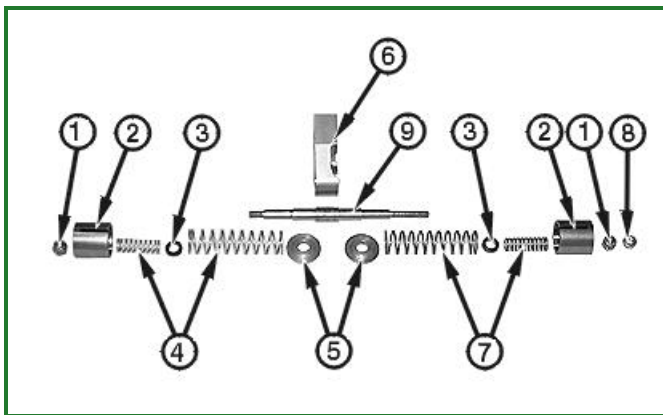

T119642B-UN: SLC Steer Shaft Disassemble

LEGEND:

- 1 - Spring End Lock Nut (2 used)
- 2 - Spring Guide (2 used)
- 3 - Spacer (2 used)
- 4 - Springs (Chrome)
- 5 - Spring Seat (2 used)
- 6 - Steering Plate
- 7 - Springs (Gold)
- 8 - Rod End Lock Nut
- 9 - Steer Shaft

- 7.

NOTE:

Use two wrenches to loosen spring end lock nuts (1).

NOTE:

Springs are color coded to aid in assembly.

Remove one spring end lock nut (1), spring guide (2), spacer (3), spring (4) or (7) and spring seat (5) from one side of steering plate (6).

8. Place steer shaft (9) in soft jaw vise and remove spring end lock nut (1), spring guide (2), spacer (3),

spring (4) or (7) and spring seat (5) from other side of steering plate.

9. Remove two socket head cap screws (1), retaining plate (2) and detent spring (3).

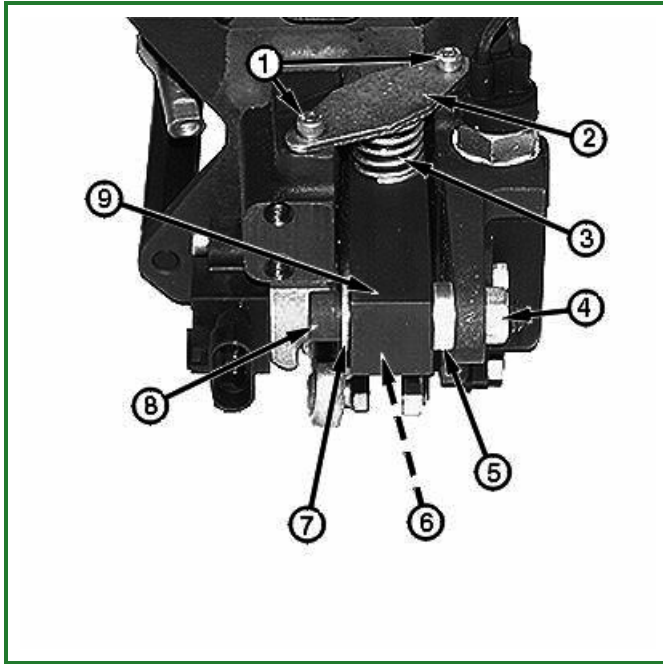

T119643B-UN: SLC Detent Spring

LEGEND:

- 1 - Socket Head Cap Screws (2 used)
- 2 - Retaining Plate
- 3 - Detent Spring
- 4 - Nut
- 5 - Spacer
- 6 - Tube
- 7 - Washer
- 8 - Socket Head Cap Screw
- 9 - Detent Lever

10. Remove nut (4), socket head cap screw (8), spacer (5), washer (7) and detent lever (9).

11. Remove tube (6) from detent lever.

12. Remove socket head cap screws from steer sensor (1) and forward/reverse sensor (2).

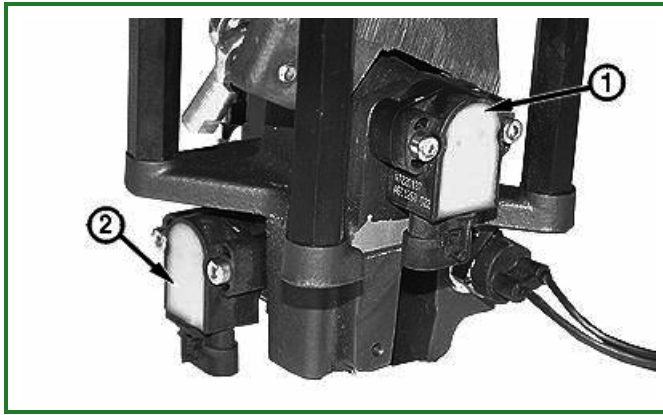

T119644B-UN: Steer and FNR Sensors

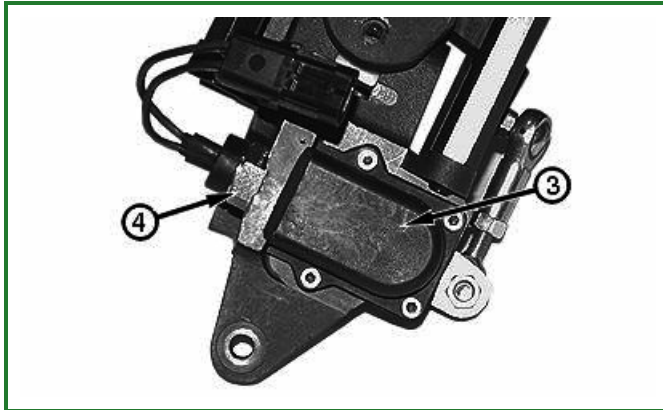

T119645B-UN: SLC Neutral Start Switch and Cover

LEGEND:

- 1 - Steer Sensor
- 2 - Forward/Reverse Sensor
- 3 - Cover
- 4 - Neutral Start Switch

Remove sensors and O-rings.

13. Remove cover (3) and neutral start switch (4).

14. Disconnect forward/reverse rod end (1) and remove steer rod end (2) from bracket assembly (3).

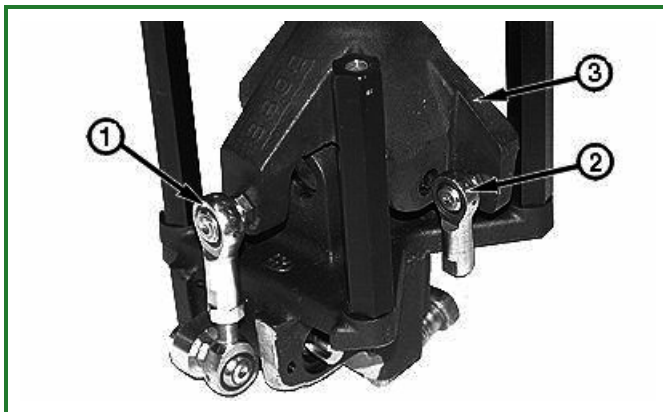

T119646B-UN: SLC Steer and FNR Rod Ends

LEGEND:

- 1 - Forward/Reverse Rod

2 - Steer Rod

3 - Bracket Assembly

15.

NOTE:

Care should be taken to avoid damaging bearing block, bearings and seals.

Remove two seal plugs and using a 1/4 in. punch with rounded edges, drive pivot pin (1) from bracket assembly. Remove bracket.

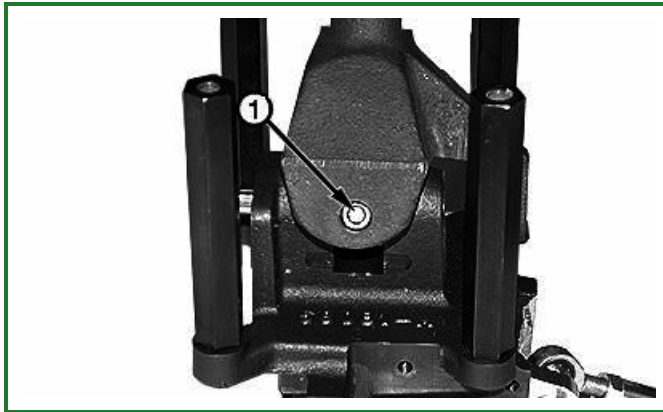

T119649B-UN: SLC Pivot Pin

LEGEND:

1 - Pivot Pin

16. Remove steer sensor shaft (2) and bearing block (1).



T119650B-UN: SLC Steer Sensor Shaft and Bearing Block

LEGEND:

1 - Bearing Block

2 - Steer Sensor Shaft

17.

NOTE:

When driving pin out of detent plate, support assembly to prevent damage to bearings and seals.

With the detent placed at the furthest reverse position, drive spring pin (1) out until detent plate (2) can be rotated around detent shaft (3).

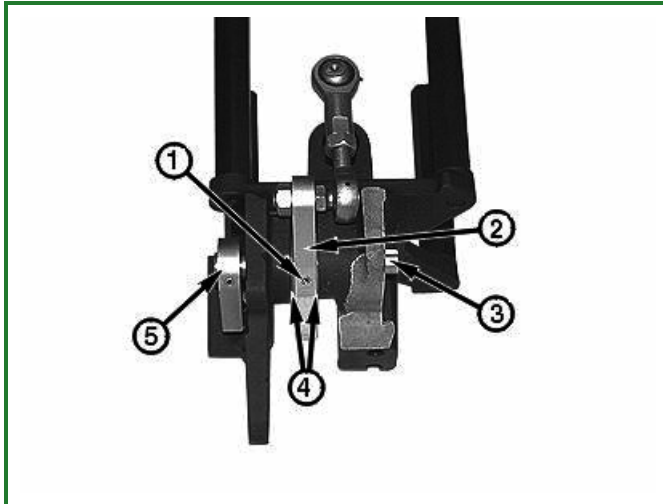

T119651B-UN: SLC Detent Plate and Shaft

LEGEND:

- 1 - Spring Pin
- 2 - Detent Plate
- 3 - Detent Shaft
- 4 - Spacers (2 used)
- 5 - Cam

18. Remove detent shaft (3) by pulling on cam (5). Be sure to catch detent plate (2) with rod end assembly and two spacers (4) when removing detent shaft.
19. Remove rod end assembly from detent plate, if replacement is required.
20. Remove cam (5) from detent shaft (3) by driving out spring pin, if replacement is required.
21. Remove pin (1) from detent plate.

22.

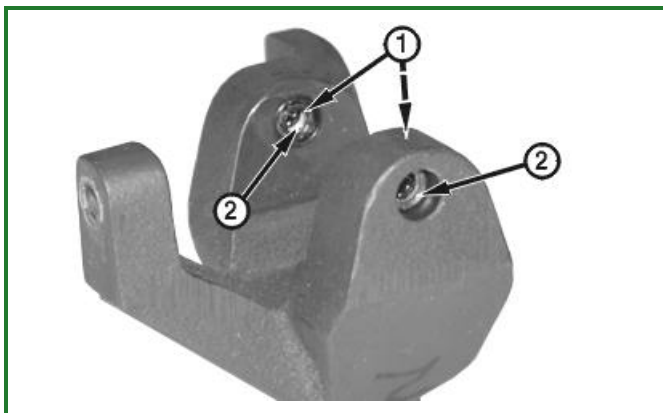

T121377B-UN: Yoke Pivot Pin Seal and Bearing

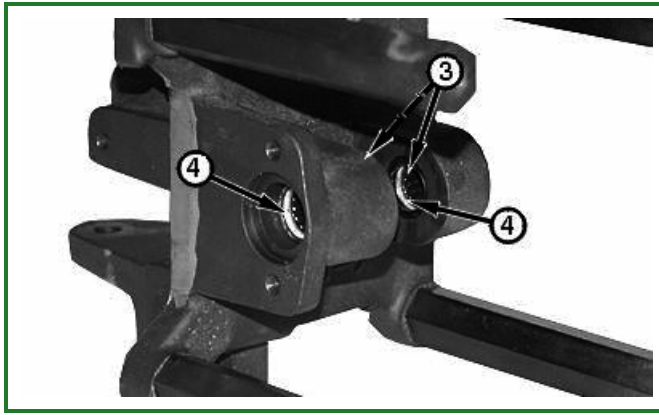

T121378B-UN: Steer Shaft Seal and Bearing

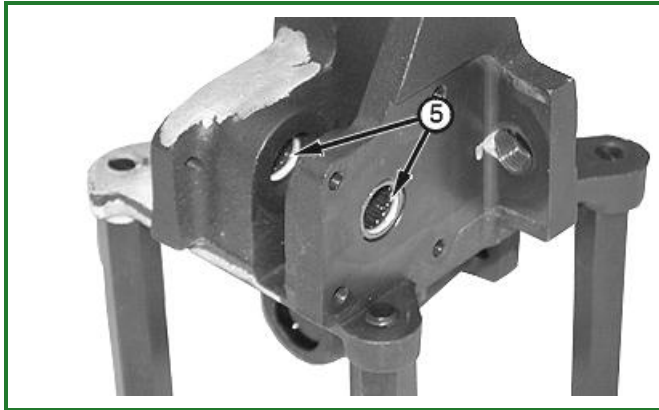

T121379B-UN: Detent Shaft Bearings

LEGEND:

- 1 - Yoke Pivot Pin Seal (2 used)
- 2 - Yoke Pivot Pin Bearing (2 used)
- 3 - Steer Shaft Seal (2 used)
- 4 - Steer Shaft Bearing (2 used)
- 5 - Detent Shaft Bearing (2 used)

Remove yoke pivot pin seals (1) and steer shaft seals (3) using a pick.

23. Remove yoke pivot pin bearings (2) using a punch.

24. Remove steer shaft bearings (4) and detent shaft bearings (5) using JDG1303-1 Bearing Driver and JDG1303-2 or JDG1303-3 Sleeve from JDG1303 Bearing Driver Kit.

25. Clean and inspect parts.

26. IMPORTANT:

Drive bearing from lettered side of bearing only.

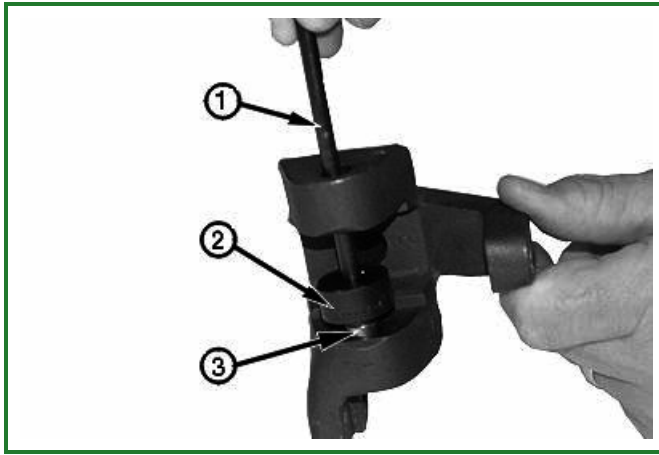

T121380B-UN: Install Yoke Bearing

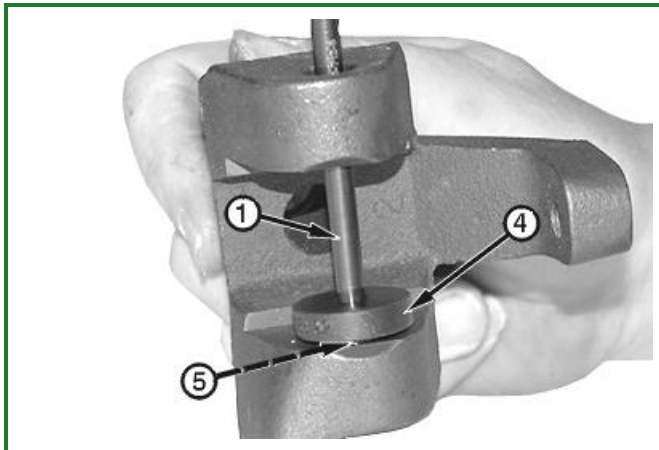

T121381B-UN: Install Yoke Seal

LEGEND:

- 1 - JDG1305-5 Driver Rod
- 2 - JDG1303-4 Driver Disk
- 3 - Yoke Pivot Pin Bearing (2 used)
- 4 - JDG1303-7 Driver Disk
- 5 - Yoke Pivot Pin (2 used)

Install yoke pivot pin bearing (3) using JDG1303-4 Driver Disk and JDG1303-5 Driver Rod. Drive bearing until driver disk is fully seated on yoke, this will set bearing to proper depth.

27. Repeat step 28 for installing other yoke pivot pin bearing.

28. IMPORTANT:

Lip side of seal must face away from bearing.

Apply petroleum jelly to seal and install seal (5) on JDG1303-7 Driver Disk (4) with lip of seal facing toward driver disk.

29. Place seal and driver disk square on yoke. Insert JDG1303-5 Driver Rod and drive seal until driver disk is fully seated on yoke.

30. Repeat steps 30 and 31 for installing other yoke pivot pin seals.

31. IMPORTANT:

Drive bearing from lettered side of bearing only.

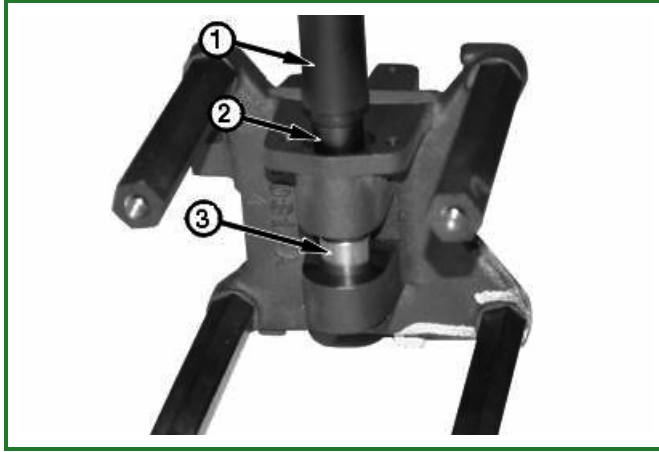

T121382B-UN: Install Steer Shaft Cap Bearing

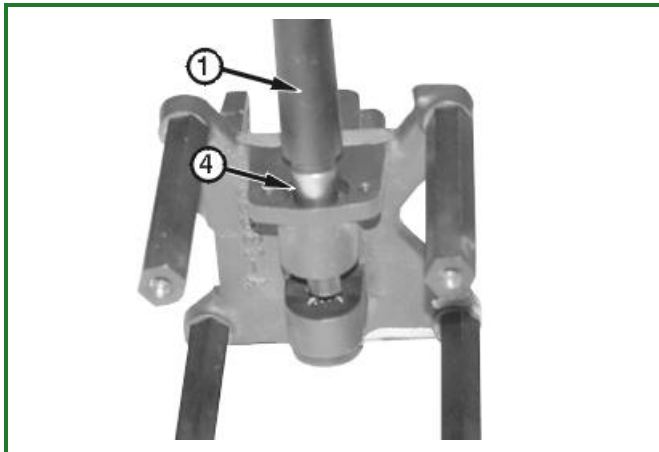

T121383B-UN: Install Steer Shaft Bearing

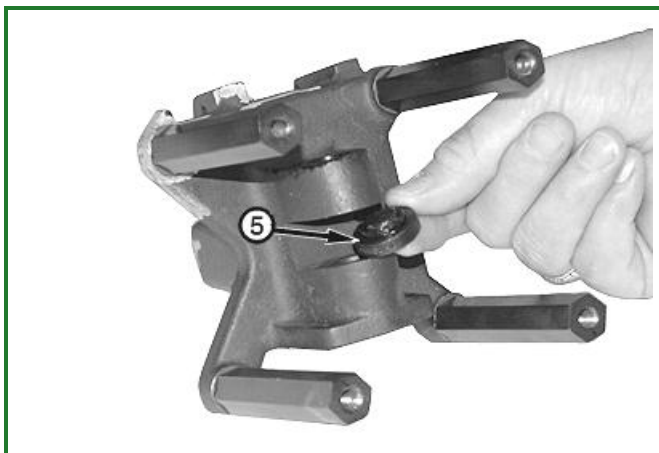

T121384B-UN: Install Steer Shaft Bearing

LEGEND:

- 1 - JDG1303-1 Bearing Driver
- 2 - JDG1303-3 Sleeve
- 3 - Steer Shaft Cap Bearing
- 4 - Steer Shaft Bearing
- 5 - Steer Shaft Seal (2 used)

Install steer shaft cap bearing (3) using JDG1303-1 Bearing Driver (1) and JDG1303-3 Sleeve (2). Drive bearing until driver is fully seated, this will set bearing to proper depth.

32. Install steer shaft bearing (4) using JDG1303-1 Bearing Driver. Drive bearing until driver is fully seated, this will set bearing to proper depth.

33. IMPORTANT:

Lip side of seal must face away from bearing.

Apply petroleum jelly to seals install seal (5) on JDG1303-6 Driver Disk with lip of seal facing toward driver disk.

34. Place seal and driver disk square in opening and firmly press with finger pressure to install seal. Press disk driver until fully seated.

35. Repeat step 35 and 36 to install other steer shaft seals.

36. IMPORTANT:

Drive bearing from lettered side of bearing only.



T121385B-UN: Install Detent Shaft Bearing

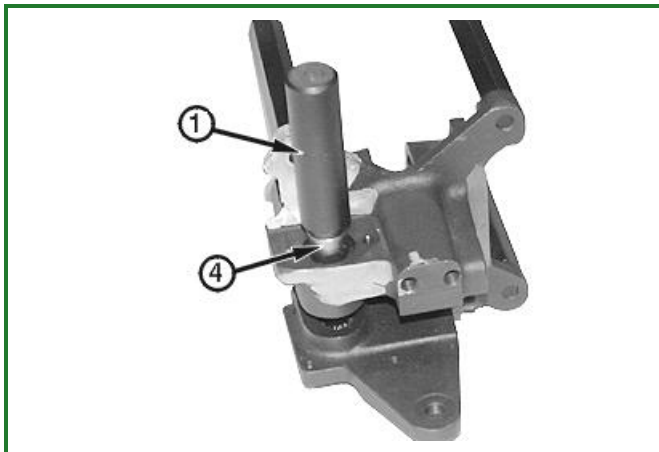

T121386B-UN: Install Detent Shaft Bearing

LEGEND:

1 - JDG1303-1 Bearing Driver

2 - JDG1303-2 Sleeve

3 - Detent Shaft Bearing

4 - Detent Shaft Bearing

Install detent shaft bearing (3) from the stepped recess side (yellow) opening. Using JDG1303-1 Bearing Driver (1) and JDG1303-2 Sleeve (2), drive bearing through until bearing driver is fully seated. This will set bearing to proper depth.

37. Install detent shaft bearing (4) using JDG1303-1 Bearing Driver. Drive bearing until bearing driver is fully

seated, this will set bearing to proper depth.

38.

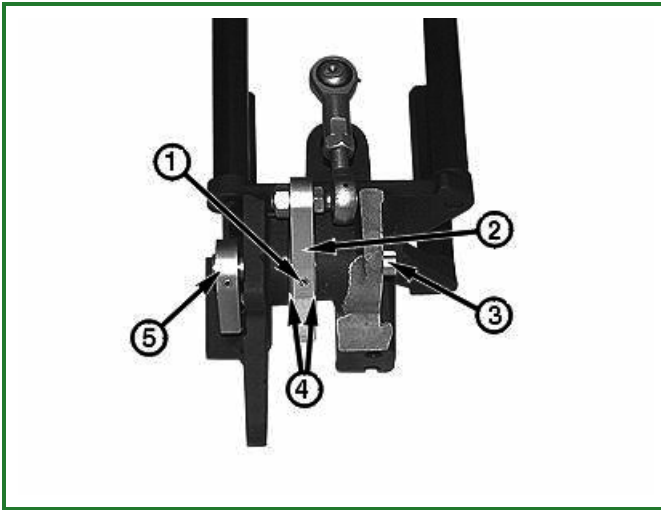

T119651B-UN: SLC Detent Plate and Shaft

LEGEND:

- 1 - Spring Pin
- 2 - Detent Plate
- 3 - Detent Shaft
- 4 - Spacers (2 used)
- 5 - Cam

Install rod on detent plate, if removed. Tighten nut to specifications.

Item	Measurement	Specification
Single Lever Control		
Detent Plate Rod Ball Joint Nut Torque		19 N·m 14 lb-ft 168 lb-in.

39. Install cam (5) on detent shaft and install spring pin.

40.

NOTE:

When driving pin in detent plate, support assembly to prevent damage to bearings and seals.

While holding detent plate (2) and spacers (4) in place, install detent shaft (3) as shown with spring pin holes for plate and cam in line. Install spring pin (1) in detent plate.

41.

NOTE:

Align pin bore in bearing block and sensor shaft.

Install bearing block (1) and steer sensor shaft (2).

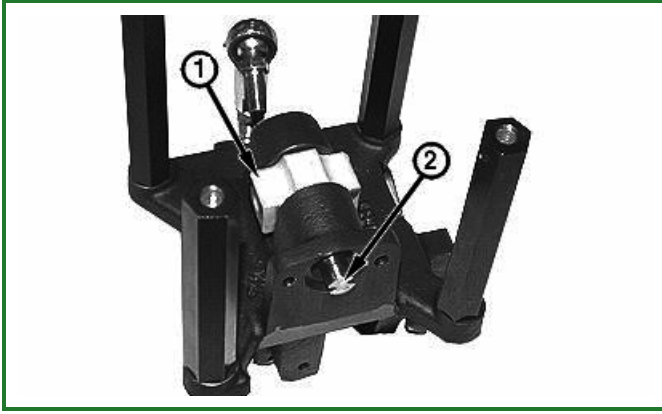

T119650B-UN: SLC Steer Sensor Shaft and Bearing Block

LEGEND:

1 - Bearing Block

2 - Steer Sensor Shaft

42.

NOTE:

Care should be taken to avoid damaging bearing block, bearings and seals.

Install lever assembly, and using a 1/4 in. punch with rounded edges, drive pivot pin (1) into bracket assembly. Pin should protrude equally on both ends.

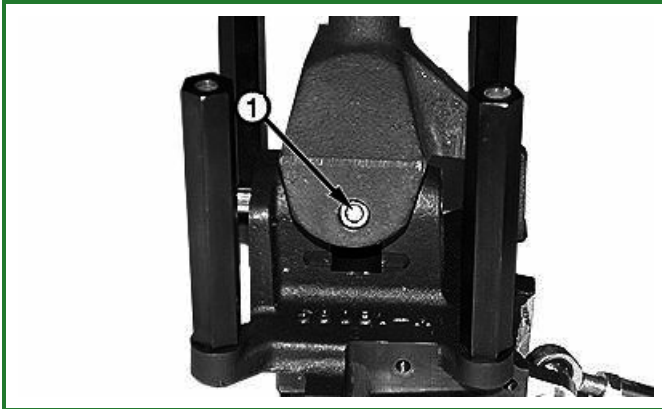

T119649B-UN: SLC Pivot Pin

LEGEND:

1 - Pivot Pin

43. Install seal plugs.

44.

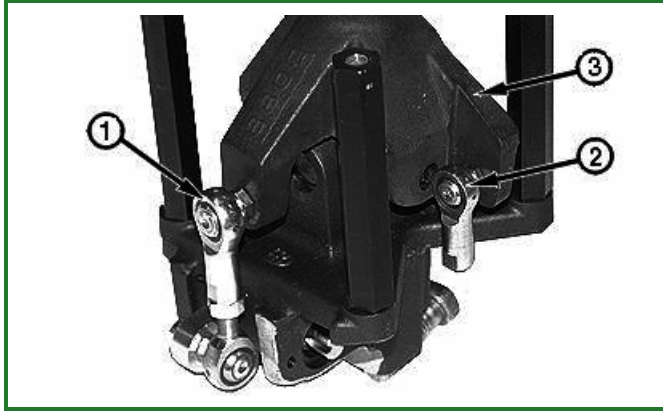
**T119646B-UN: SLC Steer and FNR Rod Ends****LEGEND:**

- 1 - Forward/Reverse Rod
- 2 - Steer Rod
- 3 - Bracket Assembly

Apply cure primer and thread lock and sealer (medium strength) to threads of rod ends. Connect forward/reverse rod end (1) and install steer rod end (2) on bracket assembly (3). Tighten ball joint nuts to specifications.

Item	Measurement	Specification
Single Lever Control		
Forward/Reverse Rod Ball Joint Nut	Torque	14 N·m 10 lb-ft 124 lb-in.
Steer Rod Ball Joint Nut	Torque	9 N·m 7 lb-ft 84 lb-in.

45.

NOTE:

Steer sensor and forward/reverse sensors are interchangeable.

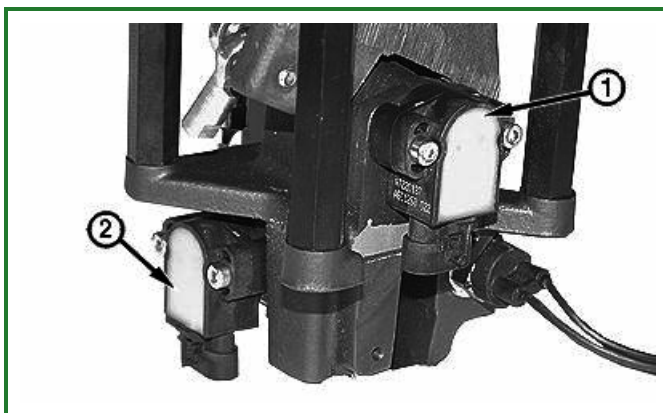
**T119644B-UN: Steer and FNR Sensors**

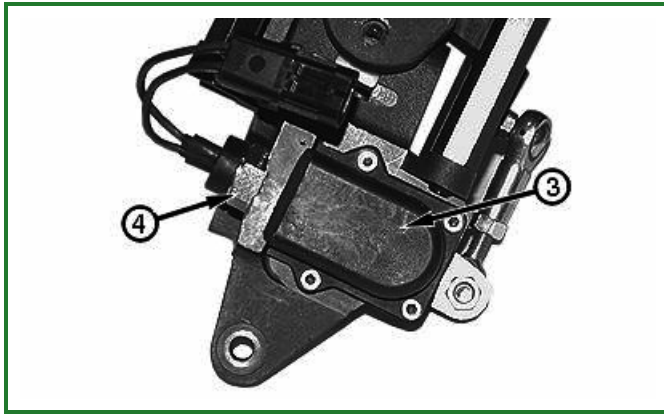
**T119645B-UN: SLC Neutral Start Switch and Cover****LEGEND:**

- 1 - Steer Sensor
- 2 - Forward/Reverse Sensor
- 3 - Cover
- 4 - Neutral Start Switch

Install sensors (1 and 2) and O-rings. Tighten cap screws to specifications.

Item	Measurement	Specification
Single Lever Control		
Steer Sensor Mounting Cap Screws	Torque	5 N·m 4 lb-ft 48 lb-in.
Forward/Reverse Sensor Mounting Cap Screws	Torque	5 N·m 4 lb-ft 48 lb-in.

46. Install neutral start switch (4) and tighten to specifications.

Item	Measurement	Specification
Single Lever Control		
Neutral Start Switch	Torque	14 N·m 10 lb-ft 124 lb-in.

47. Install cover (3) and tighten cap screws to specifications.

Item	Measurement	Specification
Single Lever Control		
Neutral Start Switch Cover Cap Screws	Torque	5 N·m 4 lb-ft 48 lb-in.

48.

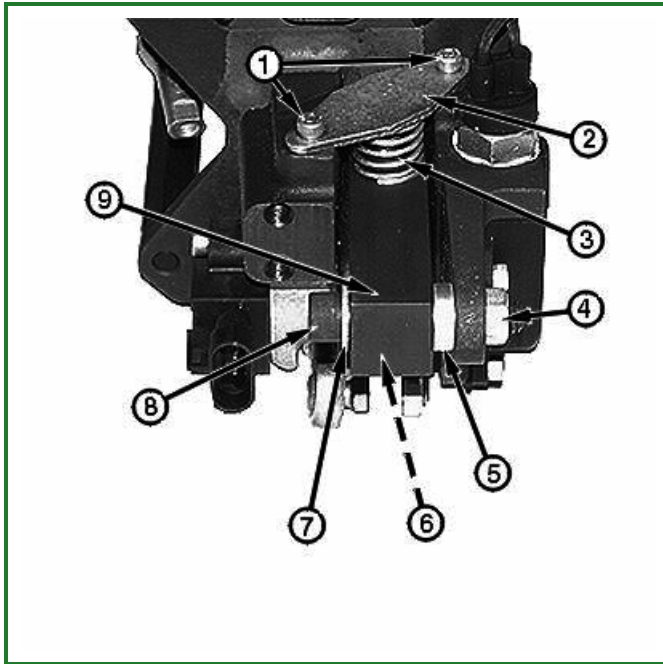
**T119643B-UN: SLC Detent Spring****LEGEND:**

- 1 - Socket Head Cap Screws (2 used)
- 2 - Retaining Plate
- 3 - Detent Spring
- 4 - Nut
- 5 - Spacer
- 6 - Tube
- 7 - Washer
- 8 - Socket Head Cap Screw
- 9 - Detent Lever

Install tube (6), washer (7), spacer (5), socket head cap screw (8) and nut (4). Tighten cap screw first and then nut, to specifications.

Item	Measurement	Specification
Single Lever Control		
Detent Lever Socket Head Cap Screw and Nut Torque		19 N·m 14 lb-ft 168 lb-in.

49. Install detent spring (3), retaining plate (2) and socket head cap screws (1). Tighten cap screws to specifications.

Item	Measurement	Specification
Single Lever Control		
Detent Spring Retaining Plate Cap Screws Torque		5 N·m 4 lb-ft 48 lb-in.

50.

NOTE:

Steering plate (6) must be installed so that the flat side faces chrome spring (4).

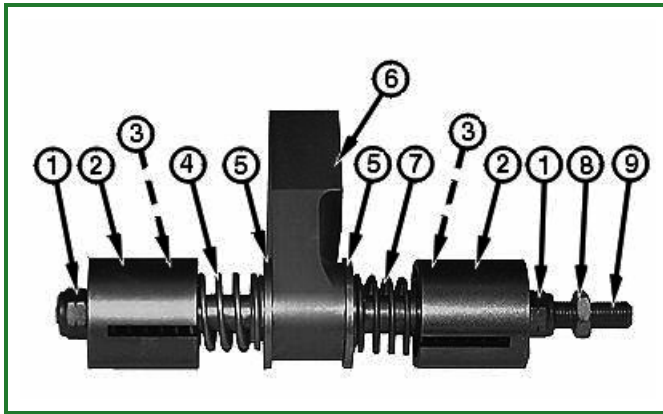

T119641B-UN: SLC Steer Shaft

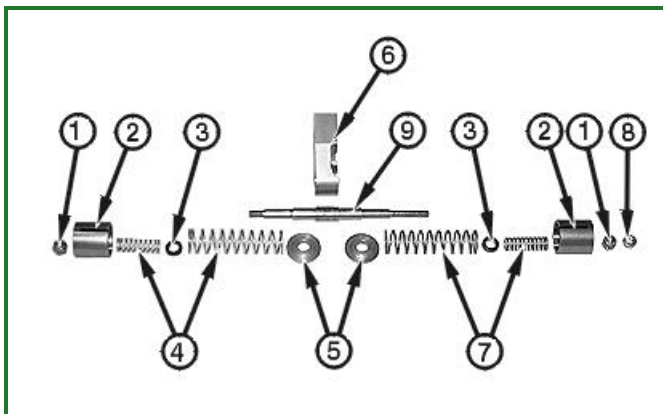

T119642B-UN: SLC Steer Shaft Disassemble

LEGEND:

- 1 - Spring End Lock Nut (2 used)
- 2 - Spring Guide (2 used)
- 3 - Spacer (2 used)
- 4 - Springs (Chrome)
- 5 - Spring Seat (2 used)
- 6 - Steering Plate
- 7 - Springs (Gold)
- 8 - Rod End Lock Nut
- 9 - Steer Shaft

Place steering shaft in soft jaw vise. Install steering plate (6), spring seat (5), spring (4) or (7), spacer (3) spring guide (2) and spring end lock nut (1). Repeat steps for opposite end, then tighten spring end lock nuts (1) to specifications.

Item	Measurement	Specification
Single Lever Control		
Steer Shaft Spring End Lock Nuts	Torque	8 N·m 6 lb-ft 72 lb-in.

51. Install rod end lock nut (8).

52.

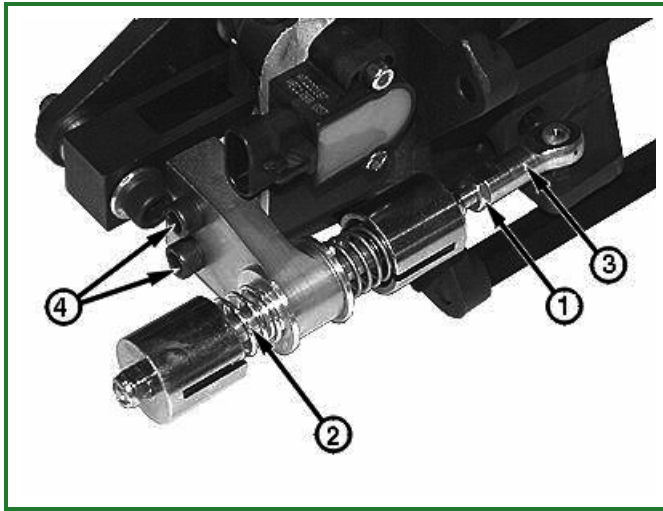
**T119639B-UN: SLC Steer Shaft Removal****LEGEND:**

- 1 - Lock Nut
- 2 - Steer Shaft
- 3 - Rod End
- 4 - Socket Head Cap Screw (2 used)

Install steer shaft assembly and two socket head cap screws (4). Tighten cap screws to specifications.

Item	Measurement	Specification
Single Lever Control		
Steer Shaft Assembly Mounting Cap Screws	Torque	34 N·m 25 lb-ft

53. Screw steer shaft into rod end (3) and tighten lock nut (1).

54.

**T124646B-UN: Speed In Grip Switch**

If removed, install boot (3) and switch (2) in grip (1).

55.



T124645B-UN: SLC Assembly

Install and tighten screws (1—3).

56. IMPORTANT:

Tie bands **MUST** be installed and wire lead **MUST** be positioned in clamp between assembly marks to provide a loop in wiring harness for steering.



T124638B-UN: FNR Assembly With Speed In Grip

Install tie bands (1) on wire harness.

57. Install clamp (3).

58.

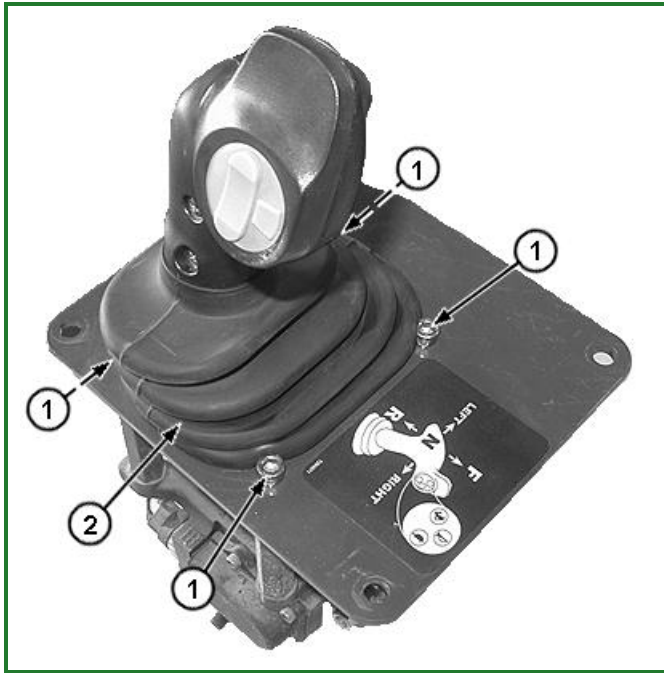
**T199277A-UN: Transmission Control Lever (TCL)****LEGEND:**

1 - Socket Head Cap Screw (4 used)

Install four socket head cap screws (1) and tighten to specification.

Item	Measurement	Specification
Transmission Control Lever (TCL) Top Plate Socket Head Cap Screws	Torque	9 N·m 6.6 lb ft

59. Install boot (2).

60.

**T199276A-UN: Transmission Control Lever (TCL)**Install transmission control lever (TCL) assembly inside console. [See Transmission Control Lever \(TCL\) Remove and Install . \(Group 0315.\)](#)

Install four cap screws (1) and tighten to specification.

Item	Measurement	Specification
Transmission Control Lever (TCL) Top Plate Cap Screws	Torque	37 N·m 27 lb ft

61. Adjust single lever control. [See Transmission Control Lever \(TCL\) Adjustment](#) . (Group 9015-20.)
62. Recalibrate transmission controller. [See Transmission Control Unit \(TCU\) Calibration](#) . (Group 9015-20.)

Go to [Section_03:Group_0315](#)

CED,OUTX547,108-19-19990929

Hydrostatic Pumps Disassemble

1.

⚠ CAUTION:

The weight of the hydrostatic pump is approximately 60 kg (133 lb). Use proper lifting equipment and safety precautions. Failure to do so may cause personal injury.

Item	Measurement	Specification
Hydrostatic Pump		
Hydrostatic Pump Weight		60 kg Approximate 133 lb Approximate

IMPORTANT:

Absolute cleanliness is essential when working on hydraulic components.

NOTE:

Orientate double boss of pump housing on holding fixture as shown.

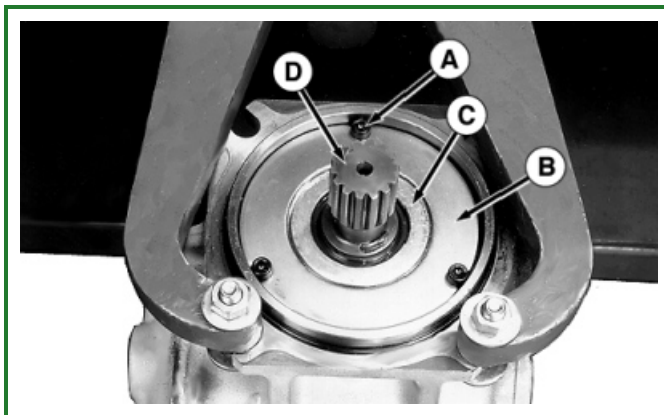

RW25727-UN: Seal Carrier, Retaining Screws and Plate

LEGEND:

- A - Socket Head Cap Screw (3 used)
- B - Retaining Plate
- C - Seal Carrier
- D - Shaft

Mount the hydrostatic pump on a D01006AA Bench-Mounted Holding Fixture.

2. Remove displacement control valve assembly. [See Pump Displacement Control Valve \(PDCV\) Disassemble and Assemble . \(Group 0360.\)](#)

3.

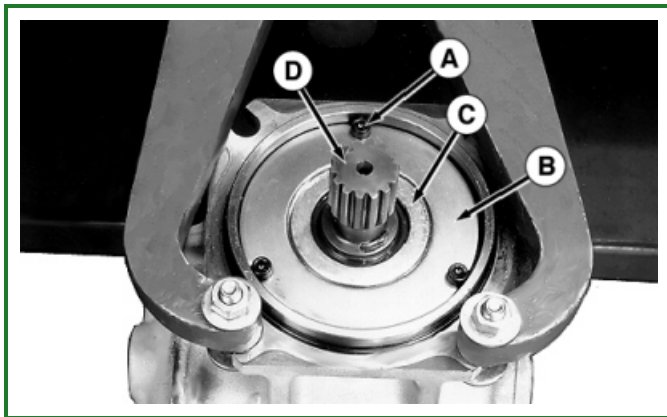

RW25727-UN: Retaining Plate

LEGEND:

- A - Socket Head Cap Screw (3 used)
- B - Retaining Plate
- C - Seal Carrier
- D - Shaft

Remove socket head cap screws (A) and retaining plate (B).

4.

NOTE:

The bearings on shaft (D) are slip fit in the housing bore.

Remove seal carrier (C) and shaft (D) with bearings. Lightly tap on opposite end of shaft to aid in removal.

5.

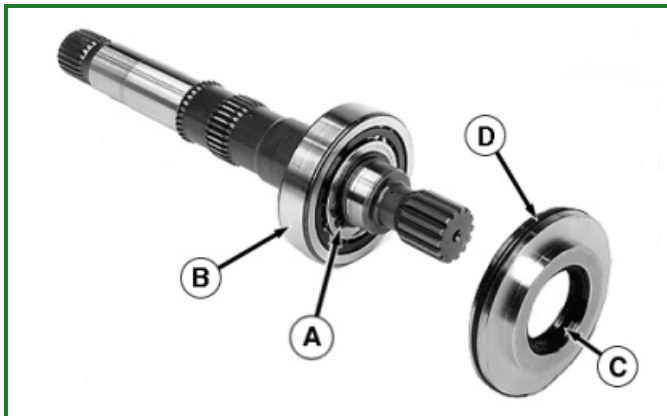

RW25728-UN: Bearing, Retaining Ring and O-Ring

LEGEND:

- A - Retaining Ring
- B - Bearing Assembly
- C - Lip Seal
- D - O-Ring

Inspect bearing assembly (B).

6. Remove retaining ring (A) and remove outer bearing assembly (B) from inner bearing race.

7. Remove inner bearing race from shaft using a press.

8. Install new inner bearing race onto shaft using a press.
9. Install new outer bearing assembly (B) and retaining ring (A) onto shaft.
10. IMPORTANT:

Cover shaft splines with shim stock to protect lip seal.

Wrap the spline or key end of shaft with thin plastic (shim stock) to prevent damage to the shaft seal lip during installation. Lubricate the inside diameter of the new seal with petroleum jelly. Install new shaft lip seal (C) in seal carrier with spring side of seal toward pump housing.

11. Install O-ring (D) on seal carrier.
12. Rotate pump 180°.

13.

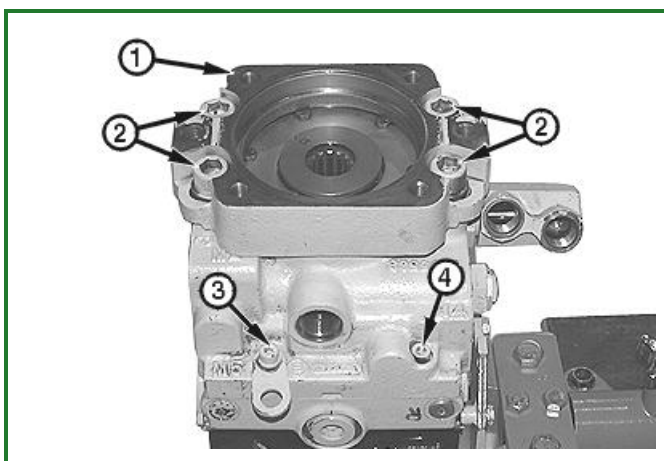

T119614B-UN: Pump End Cap

LEGEND:

- 1 - Adapter Plate
- 2 - Socket Head Cap Screw with Washer (4 used)
- 3 - Socket Head Cap Screw with Lift Bracket
- 4 - Socket Head Cap Screw

Remove the two small socket head cap screws (3 and 4) and socket head cap screws with washers (2).

14.

NOTE:

Leveler spring shims may dislodge during end cap removal.

Remove adapter plate and O-ring from end cap. Remove end cap and gasket from pump housing.

15. IMPORTANT:

Do not damage the end cap surface when removing or installing bearing (A).

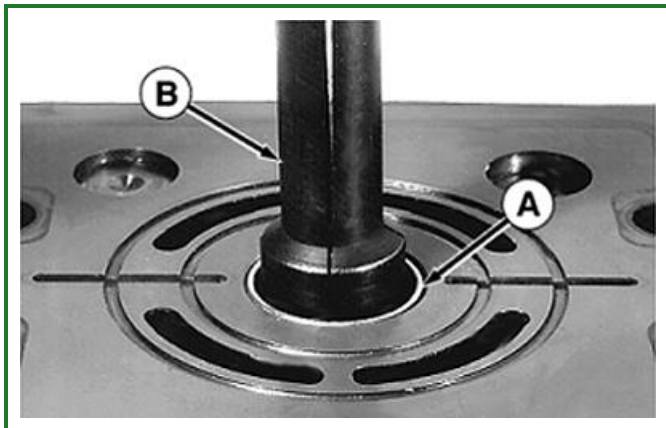

T118279-UN: Bearing Puller

LEGEND:

A - Journal Bearing

B - Blind Hole Puller

Inspect journal bearing (A).

16. Carefully remove the bearing using D01061AA Blind-Hole Puller (B).
17. Lightly lubricate the new journal bearing and install into end cap using a press.

Item	Measurement	Specification
Hydrostatic Pump		
End Cap Journal Bearing	Depth	Flush-to-0.50 mm Flush-to-0.020 in.

18. IMPORTANT:

New journal bearing MUST be sized using a JDG1072 Journal Bearing Sizing Tool. DO NOT use the pump shaft. This will cause inadequate lubrication and shortened bearing life.

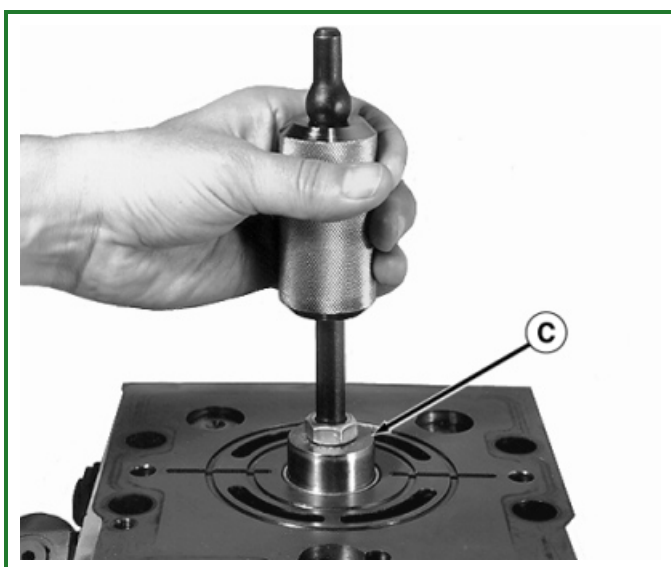

RW25782-UN: Using JDG1072 Journal Bearing Sizing Tool

LEGEND:

C - Journal Bearing Sizing Tool

Size the journal bearing using a JDG1072 Journal Bearing Sizing Tool (C).

19.

NOTE:

Shims for springs (1) may stay with the end cap during end cap removal.

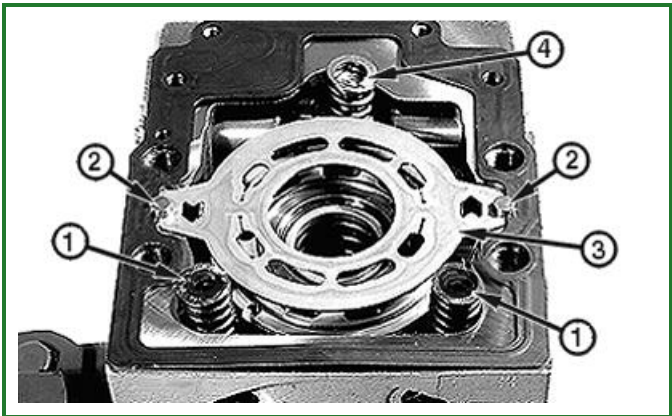

T156798B-UN: Swashplate

LEGEND:

- 1 - Spring (2 used)
- 2 - Alignment Pin (2 used)
- 3 - Valve Plate
- 4 - Hold Down Spring

Remove and inspect springs (1 and 4) and shims.

Item	Measurement	Specification
Swashplate		
Swashplate Leveling Outer Springs	Free Length	88.2 mm Approximate 3.5 in. Approximate
	Test Length	83.3 mm at 160 N 3.3 in. at 36 lb force
Swashplate Leveling Inner Springs	Free Length	81 mm Approximate 3.2 in. Approximate
	Test Length	76.2 mm at 78 N 3.0 in. at 17.5 lb force
Swashplate Hold-Down Spring	Free Length	21.6 mm Approximate 0.85 in. Approximate
	Test Length	19.8 mm at 613 N 0.78 in. at 138 lb force

20. IMPORTANT:

Note the direction of arrows stamped on valve plate and mark housing accordingly.

Remove valve plate (3).

21. Remove alignment pins (2).

22.

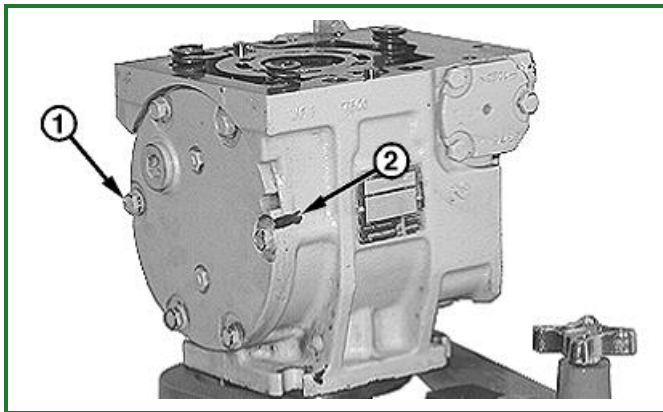
**T118259B-UN: Mark Side Cover****LEGEND:**

1 - Cap Screw (6 used)

2 - Alignment Marks

Put alignment marks (2) on the side cover and pump housing.

23. Remove and discard the six cap screws (1).

24.

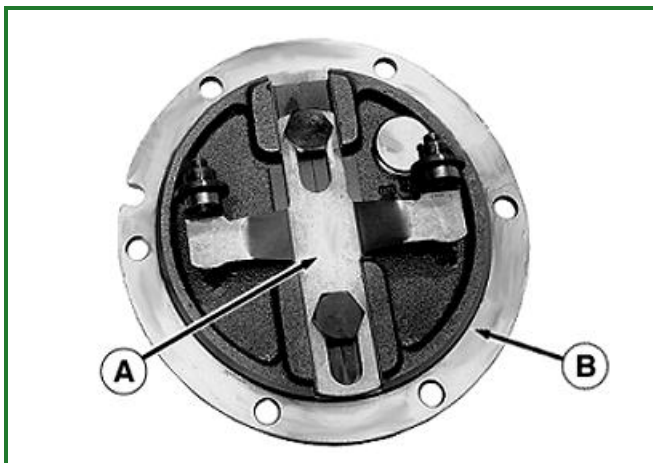
**T118277-UN: Side Cover Disassembly****LEGEND:**

A - Leveler Assembly

B - O-Ring

Remove leveler assembly (A) by removing two lock nuts on outside of cover.

25. Discard O-ring (B).

26.

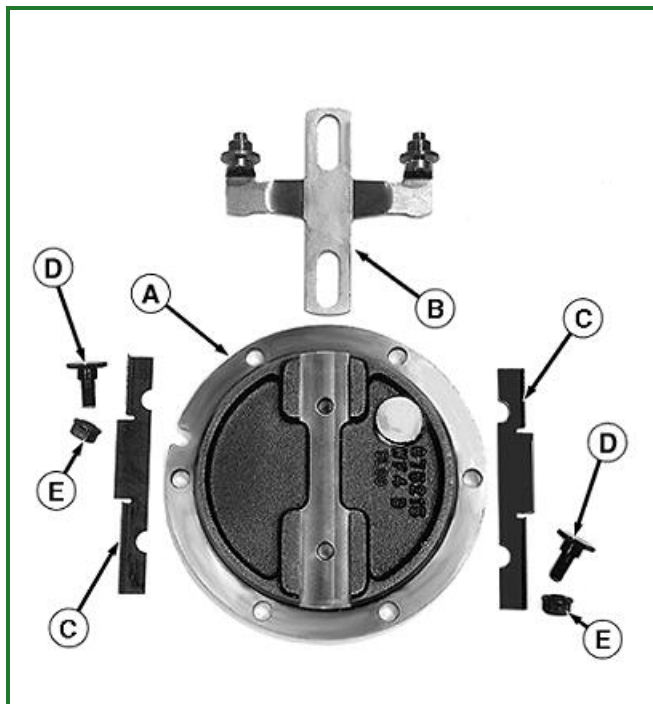

T118278-UN: Side Cover Assembly

LEGEND:

- A - Side Cover
- B - Leveler
- C - Insert (2 used)
- D - Cap Screw (2 used)
- E - Lock Nut (2 used)

Inspect parts (A—D). Replace as required.

27. Assemble side cover using new lock nuts (E). Tighten nuts to specifications.

Item	Measurement	Specification
Hydrostatic Pump		
Swashplate Leveler-to-Side Cover Lock Nuts	Torque	23 N·m 17 lb-ft 204 lb-in.

28. Install O-ring on side cover (A).

29. IMPORTANT:

Wear patterns develop between servo pistons and servo cylinders. Servo cylinders must be installed in original positions.

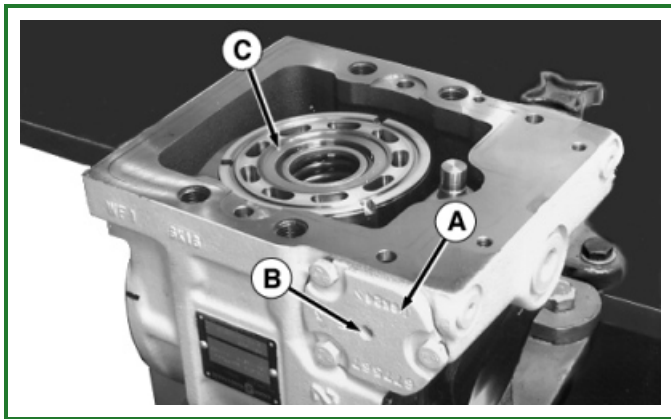

RW25735-UN: Servo Cylinders & Cylinder Block Assembly

LEGEND:

A - Servo Cylinder (2 used)

B - Threaded Hole

C - Cylinder Block Assembly

Tag or identify servo cylinders (A) for assembly into the bore from which the cylinders were removed.

- 30. Remove capscrews and remove cylinders (A) using a slide hammer and 8 mm screw in threaded hole (B).

31. IMPORTANT:

Wear patterns develop between cylinder block bores and pistons. Pistons must be installed in original cylinder block bores.

Tag or identify pistons and cylinder block bores to aid in proper assembly.

- 32. Remove cylinder block assembly (C).

33.

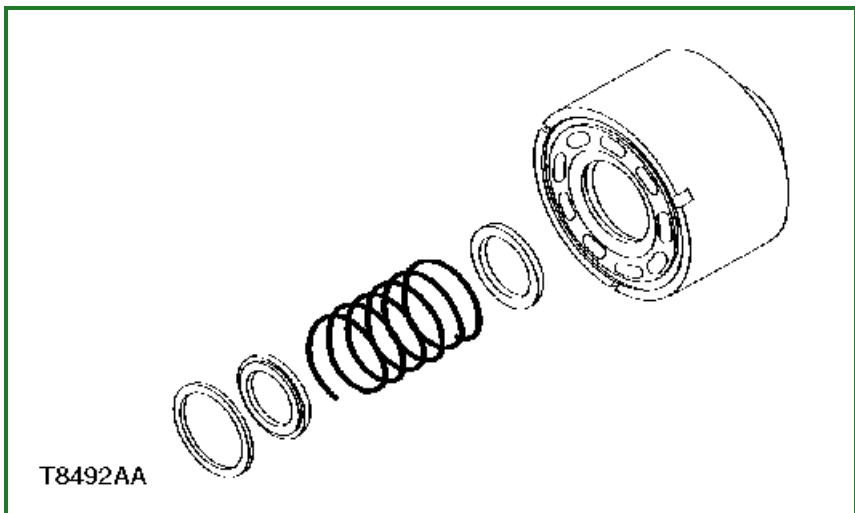

T8492AA-UN: Cylinder block spring removal

Compress the cylinder block spring using a press and remove the spiral retaining ring.

- 34. Remove retainer.
- 35. Remove spring and spring seats.

36. Clean cylinder block and components.

37. Assemble cylinder block.

38.

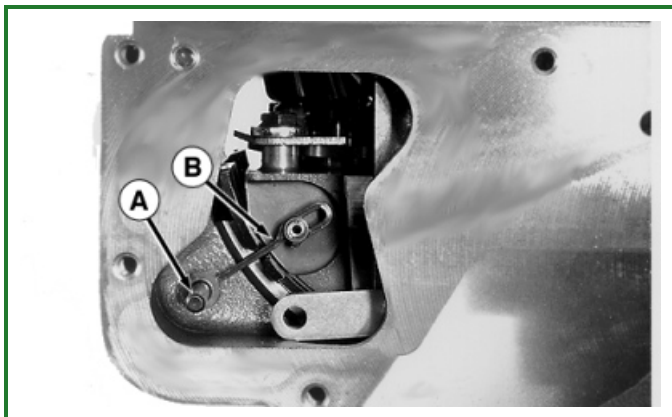

RW25736-UN: Bearing Cage Link Pin and Locator Link

LEGEND:

A - Cage Link Pin

B - Locator Link

Remove bearing cage link pin (A) and locator link (B).

39.

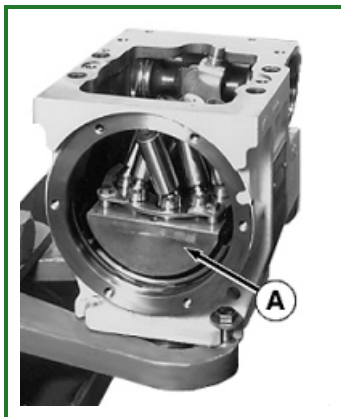

RW25737-UN: Piston Assembly

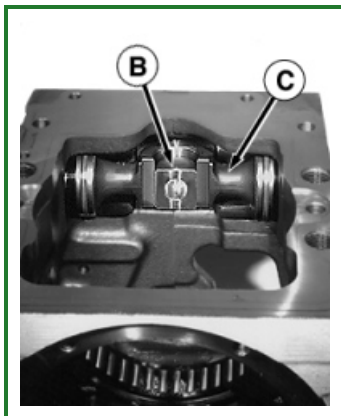

RW25738-UN: Servo Piston and Slider Block

LEGEND:

A - Swashplate and Piston Assembly

B - Slider Block

C - Servo Piston

Remove the swash plate and piston assembly (A) through the housing side cover opening.

40. IMPORTANT:

Wear patterns develop between servo pistons and servo cylinders. Servo piston must be installed with original orientation.

Tag or identify servo piston orientation to aid in proper assembly.

41. Remove the servo piston (C) and slider block (B).

42.

NOTE:

Do not stretch seal rings (B) any more than necessary when installing.



RW25739-UN: Expander O-Ring

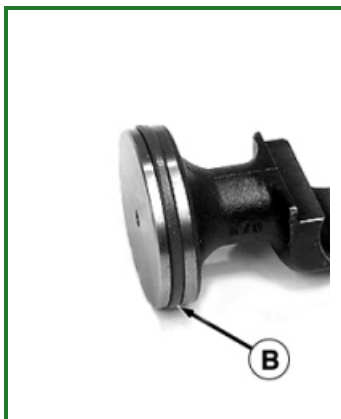

RW25740-UN: Seal Ring

LEGEND:

A - O-Ring

B - Seal Ring

Replace expander O-ring (A) on each end of servo piston.

43. Install seal ring (B) over O-ring on each end of piston.

44. IMPORTANT:

Bearing cage wears patterns in bearing race and swash plate. Components must be installed in proper

position with original orientation.

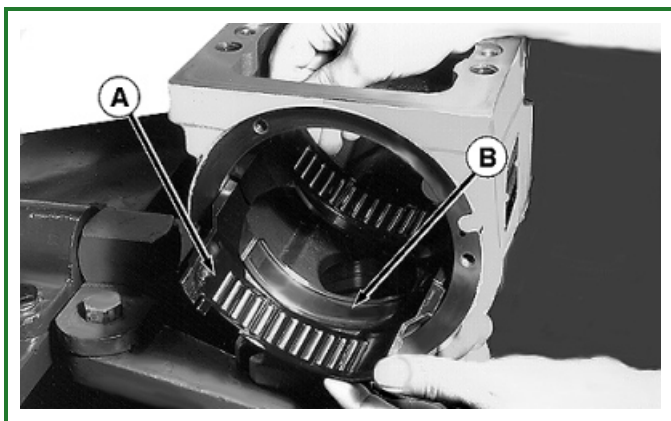

RW25741-UN: Swashplate Bearing Cage and Bearing Races

LEGEND:

A - Bearing Cage (2 used)

B - Bearing Race (2 used)

Tag or identify swash plate bearing cage positions to aid in proper assembly.

45. Remove and inspect swash plate bearing cage (A). Replace as required.

46. Tag or identify bearing race positions to aid in proper assembly.

47. Remove and inspect the two bearing races (B). Replace as required.

48. IMPORTANT:

Parts have critical, high tolerance surfaces which require careful handling to prevent damage.

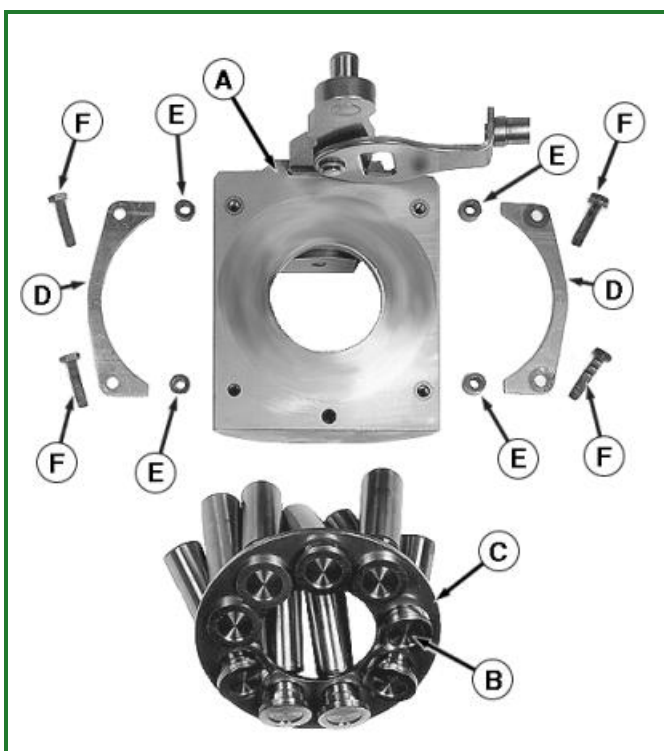

T121170-UN: Disassemble swash plate and Piston Assembly

LEGEND:

- A - Swashplate
- B - Piston Assembly (9 used)
- C - Slipper Guide
- D - Slipper Guide Bearing (2 used)
- E - Spacer (4 used)
- F - Cap Screw (4 used)

Disassemble and inspect parts (A—E) discarding cap screws (F).

49. IMPORTANT:

Servo arm alignment is critical. Do not remove servo arm (A) from swash plate unless replacing.

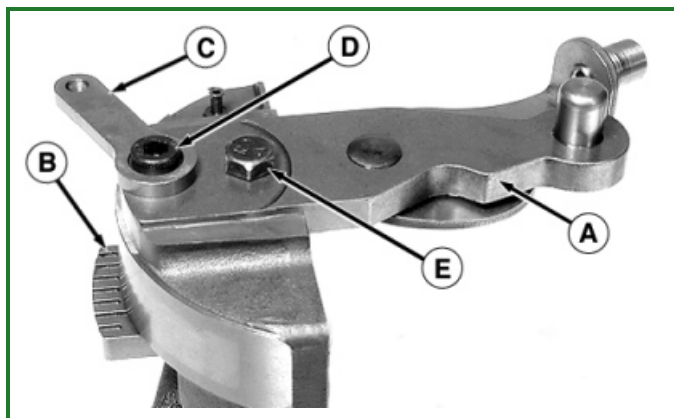

RW25742-UN: Servo Arm, Feedback Link and swash plate Guide

LEGEND:

- A - Servo Arm
- B - Swashplate Guide
- C - Feedback Link
- D - Socket Head Cap Screw
- E - Cap Screw

Remove feedback link (C) by removing socket head cap screw (D).

50. Inspect swash plate guide (B).

51. Remove cap screw (E) only if replacement of servo arm is needed.

52.

NOTE:

Servo arm is a press fit.

Install new servo arm carefully aligning the slot and threaded holes in swash plate. Arm must be pressed completely into swash plate slot.

53. Install servo arm cap screw (E) and tighten to specifications.

Item	Measurement	Specification
Hydrostatic Pump		
Swashplate Servo Arm Cap Screw	Torque	32 N·m 24 lb-ft

54. Install feedback link (C) and swash plate guide (B). Tighten socket head cap screw (D) to specifications.

Item	Measurement	Specification
Hydrostatic Pump		
Swashplate Feedback Link Cap Screw Torque		32 N·m 24 lb-ft

55. IMPORTANT:

Threaded holes in swash plate and pump housing side cover opening must be cleaned of old locking compound prior to reassembly.

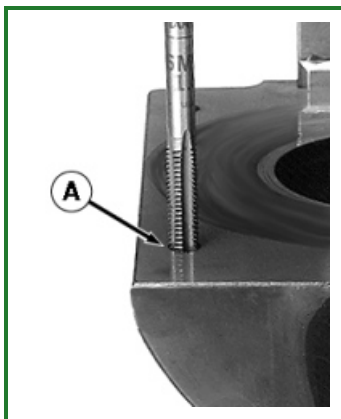

RW25729-UN: Swashplate

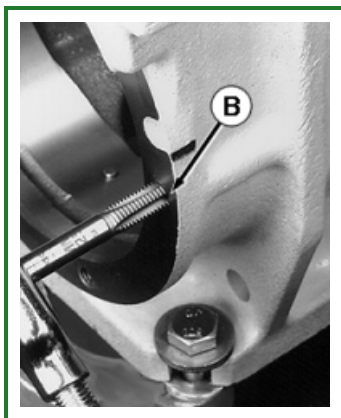

RW25744-UN: Pump Housing Side Cover Opening

LEGEND:

A - M6 Threaded Holes in Swashplate

B - M8 Threaded Holes in Housing

Clean the threaded holes in the swash plate (A) and pump housing side cover opening (B) using the correct tap.

56. IMPORTANT:

Pump housing must be clear of any contamination before assembling pump.

Clean inside of pump housing eliminating any excess thread locking compound or other contamination.

Go to [Section_03:Group_0360](#)

TE14778,0000040-19-20100622

Hydrostatic Pumps Disassemble

1.

⚠ CAUTION:

The weight of the hydrostatic pump is approximately 60 kg (133 lb). Use proper lifting equipment and safety precautions. Failure to do so may cause personal injury.

Item	Measurement	Specification
Hydrostatic Pump		
Hydrostatic Pump Weight		60 kg Approximate 133 lb Approximate

IMPORTANT:

Absolute cleanliness is essential when working on hydraulic components.

NOTE:

Orientate double boss of pump housing on holding fixture as shown.

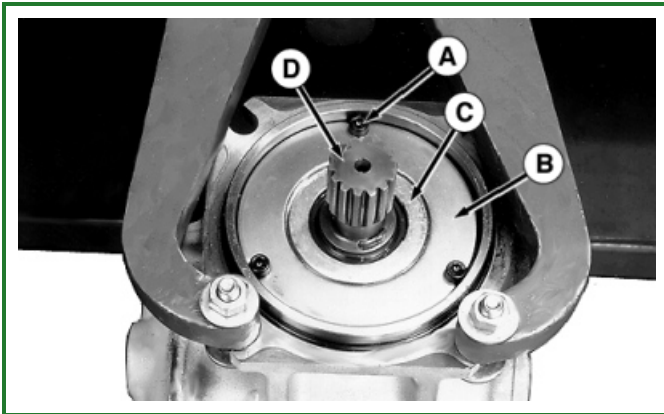

RW25727-UN: Seal Carrier, Retaining Screws and Plate

LEGEND:

- A - Socket Head Cap Screw (3 used)
- B - Retaining Plate
- C - Seal Carrier
- D - Shaft

Mount the hydrostatic pump on a D01006AA Bench-Mounted Holding Fixture.

2. Remove displacement control valve assembly. See [Pump Displacement Control Valve \(PDCV\) Disassemble and Assemble](#) . (Group 0360.)

3.

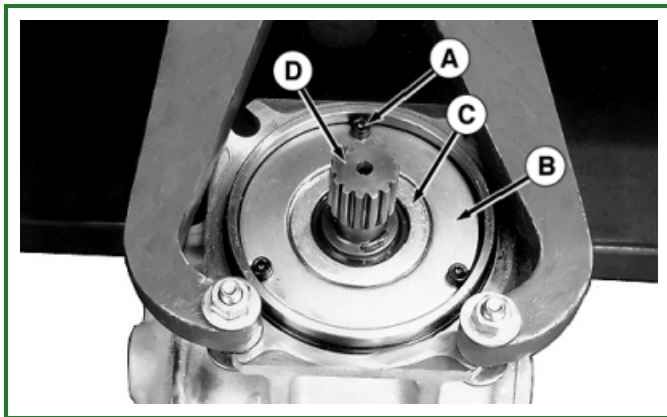
**RW25727-UN: Retaining Plate****LEGEND:**

A - Socket Head Cap Screw (3 used)

B - Retaining Plate

C - Seal Carrier

D - Shaft

Remove socket head cap screws (A) and retaining plate (B).

4.

NOTE:

The bearings on shaft (D) are slip fit in the housing bore.

Remove seal carrier (C) and shaft (D) with bearings. Lightly tap on opposite end of shaft to aid in removal.

5.

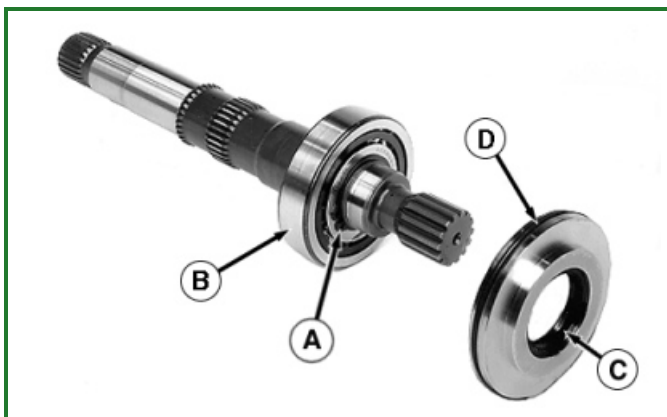
**RW25728-UN: Bearing, Retaining Ring and O-Ring****LEGEND:**

A - Retaining Ring

B - Bearing Assembly

C - Lip Seal

D - O-Ring

Inspect bearing assembly (B).

6. Remove retaining ring (A) and remove outer bearing assembly (B) from inner bearing race.

7. Remove inner bearing race from shaft using a press.

8. Install new inner bearing race onto shaft using a press.
9. Install new outer bearing assembly (B) and retaining ring (A) onto shaft.
10. IMPORTANT:

Cover shaft splines with shim stock to protect lip seal.

Wrap the spline or key end of shaft with thin plastic (shim stock) to prevent damage to the shaft seal lip during installation. Lubricate the inside diameter of the new seal with petroleum jelly. Install new shaft lip seal (C) in seal carrier with spring side of seal toward pump housing.

11. Install O-ring (D) on seal carrier.

12. Rotate pump 180°.

- 13.

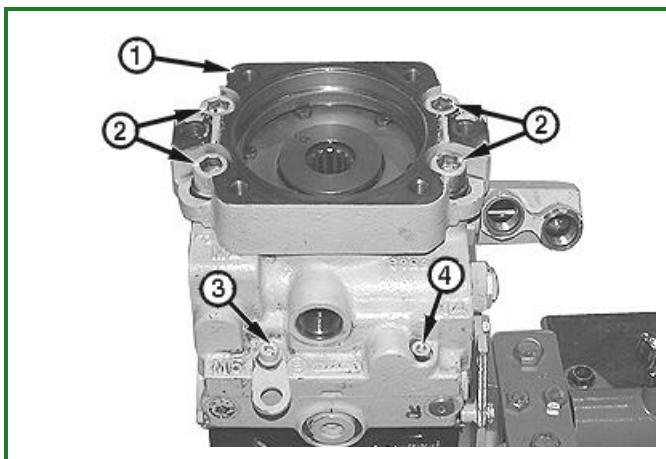

T119614B-UN: Pump End Cap

LEGEND:

- 1 - Adapter Plate
- 2 - Socket Head Cap Screw with Washer (4 used)
- 3 - Socket Head Cap Screw with Lift Bracket
- 4 - Socket Head Cap Screw

Remove the two small socket head cap screws (3 and 4) and socket head cap screws with washers (2).

- 14.

NOTE:

Leveler spring shims may dislodge during end cap removal.

Remove adapter plate and O-ring from end cap. Remove end cap and gasket from pump housing.

15. IMPORTANT:

Do not damage the end cap surface when removing or installing bearing (A).

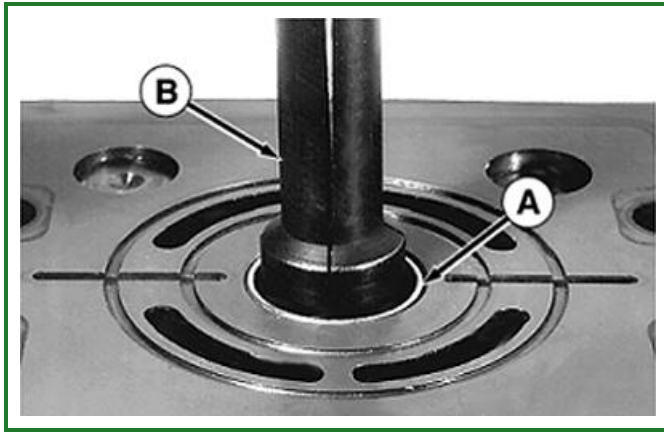

T118279-UN: Bearing Puller

LEGEND:

A - Journal Bearing

B - Blind Hole Puller

Inspect journal bearing (A).

16. Carefully remove the bearing using D01061AA Blind-Hole Puller (B).
17. Lightly lubricate the new journal bearing and install into end cap using a press.

Item	Measurement	Specification
Hydrostatic Pump		
End Cap Journal Bearing	Depth	Flush-to-0.50 mm Flush-to-0.020 in.

18. IMPORTANT:

New journal bearing **MUST** be sized using a JDG1072 Journal Bearing Sizing Tool. **DO NOT** use the pump shaft. This will cause inadequate lubrication and shortened bearing life.

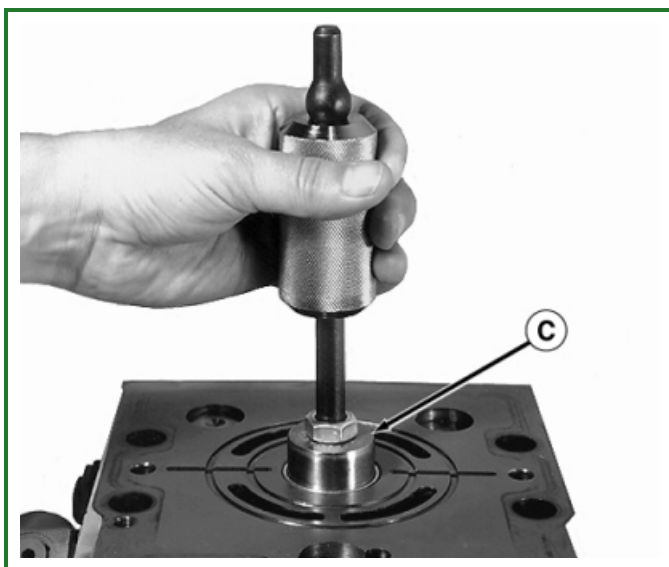

RW25782-UN: Using JDG1072 Journal Bearing Sizing Tool

LEGEND:

C - Journal Bearing Sizing Tool

Size the journal bearing using a JDG1072 Journal Bearing Sizing Tool (C).

19.

NOTE:

Shims for springs (1) may stay with the end cap during end cap removal.

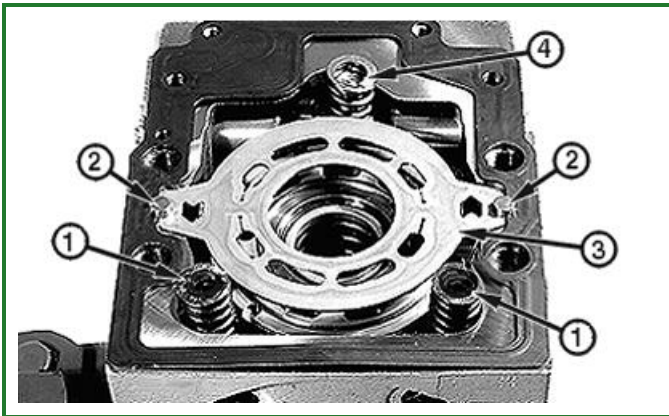

T156798B-UN: Swashplate

LEGEND:

- 1 - Spring (2 used)
- 2 - Alignment Pin (2 used)
- 3 - Valve Plate
- 4 - Hold Down Spring

Remove and inspect springs (1 and 4) and shims.

Item	Measurement	Specification
Swashplate		
Swashplate Leveling Outer Springs	Free Length	88.2 mm Approximate 3.5 in. Approximate
	Test Length	83.3 mm at 160 N 3.3 in. at 36 lb force
Swashplate Leveling Inner Springs	Free Length	81 mm Approximate 3.2 in. Approximate
	Test Length	76.2 mm at 78 N 3.0 in. at 17.5 lb force
Swashplate Hold-Down Spring	Free Length	21.6 mm Approximate 0.85 in. Approximate
	Test Length	19.8 mm at 613 N 0.78 in. at 138 lb force

20. IMPORTANT:

Note the direction of arrows stamped on valve plate and mark housing accordingly.

Remove valve plate (3).

21. Remove alignment pins (2).

22.

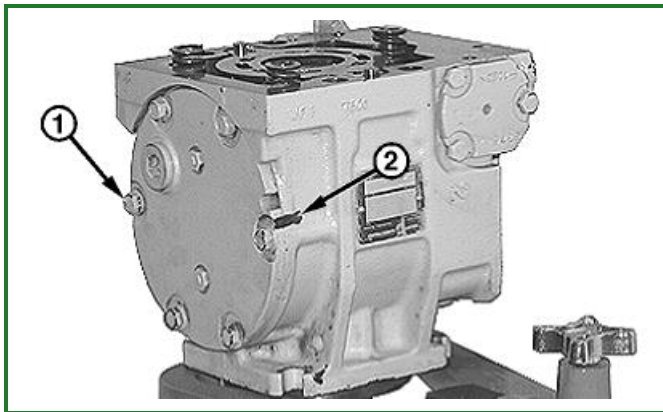

T118259B-UN: Mark Side Cover

LEGEND:

1 - Cap Screw (6 used)

2 - Alignment Marks

Put alignment marks (2) on the side cover and pump housing.

23. Remove and discard the six cap screws (1).

24.

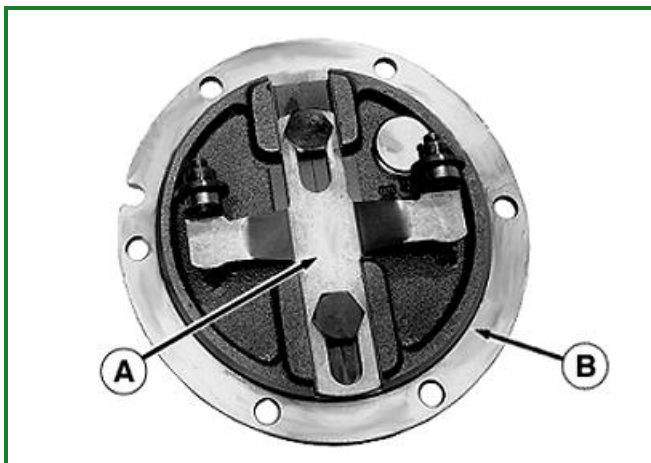

T118277-UN: Side Cover Disassembly

LEGEND:

A - Leveler Assembly

B - O-Ring

Remove leveler assembly (A) by removing two lock nuts on outside of cover.

25. Discard O-ring (B).

26.

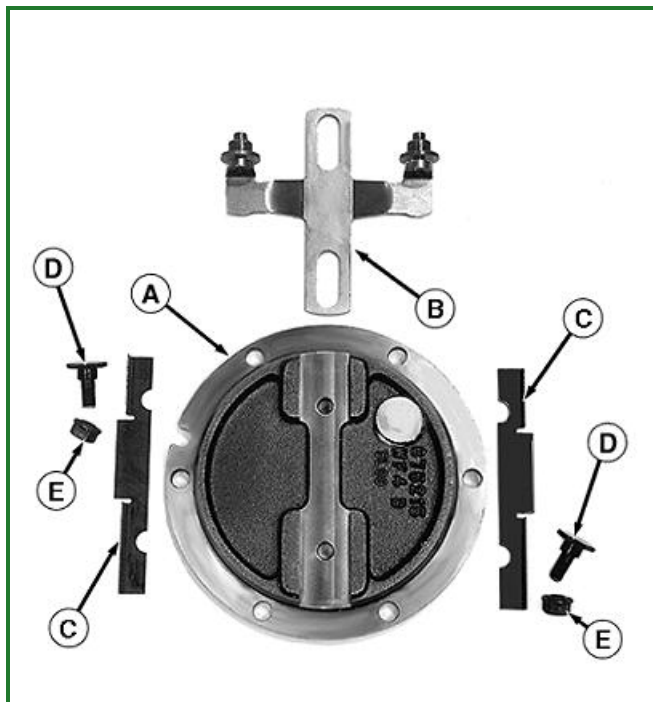

T118278-UN: Side Cover Assembly

LEGEND:

- A - Side Cover
- B - Leveler
- C - Insert (2 used)
- D - Cap Screw (2 used)
- E - Lock Nut (2 used)

Inspect parts (A—D). Replace as required.

27. Assemble side cover using new lock nuts (E). Tighten nuts to specifications.

Item	Measurement	Specification
Hydrostatic Pump		
Swashplate Leveler-to-Side Cover Lock Nuts	Torque	23 N·m 17 lb-ft 204 lb-in.

28. Install O-ring on side cover (A).

29. IMPORTANT:

Wear patterns develop between servo pistons and servo cylinders. Servo cylinders must be installed in original positions.

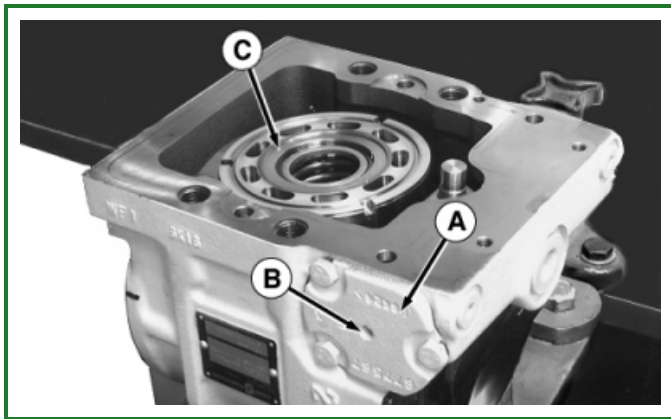

RW25735-UN: Servo Cylinders & Cylinder Block Assembly

LEGEND:

A - Servo Cylinder (2 used)

B - Threaded Hole

C - Cylinder Block Assembly

Tag or identify servo cylinders (A) for assembly into the bore from which the cylinders were removed.

30. Remove capscrews and remove cylinders (A) using a slide hammer and 8 mm screw in threaded hole (B).

31. IMPORTANT:

Wear patterns develop between cylinder block bores and pistons. Pistons must be installed in original cylinder block bores.

Tag or identify pistons and cylinder block bores to aid in proper assembly.

32. Remove cylinder block assembly (C).

33.

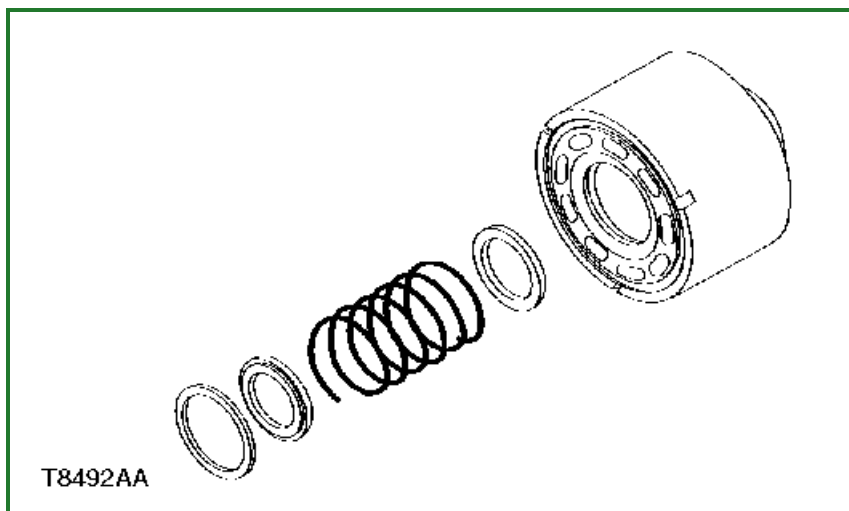

T8492AA-UN: Cylinder block spring removal

Compress the cylinder block spring using a press and remove the spiral retaining ring.

34. Remove retainer.

35. Remove spring and spring seats.

36. Clean cylinder block and components.

37. Assemble cylinder block.

38.

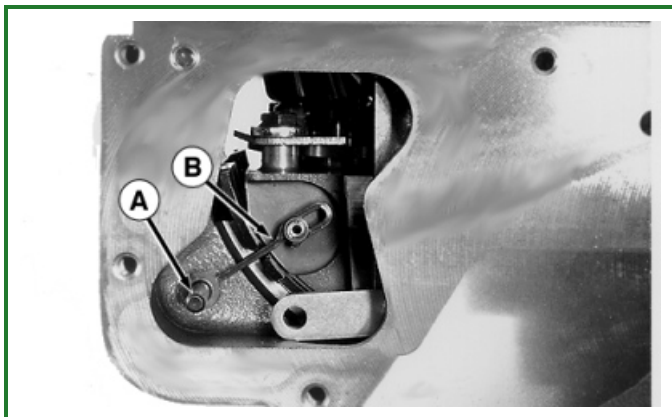

RW25736-UN: Bearing Cage Link Pin and Locator Link

LEGEND:

A - Cage Link Pin

B - Locator Link

Remove bearing cage link pin (A) and locator link (B).

39.

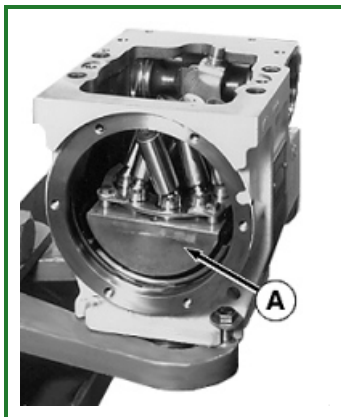

RW25737-UN: Piston Assembly

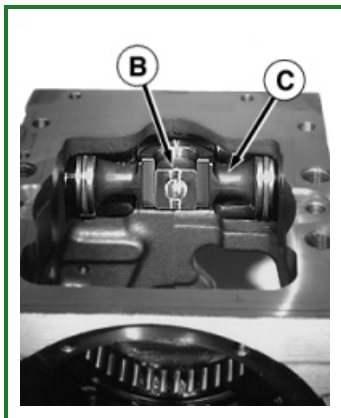

RW25738-UN: Servo Piston and Slider Block

LEGEND:

A - Swashplate and Piston Assembly

B - Slider Block

C - Servo Piston

Remove the swash plate and piston assembly (A) through the housing side cover opening.

40. IMPORTANT:

Wear patterns develop between servo pistons and servo cylinders. Servo piston must be installed with original orientation.

Tag or identify servo piston orientation to aid in proper assembly.

41. Remove the servo piston (C) and slider block (B).

42.

NOTE:

Do not stretch seal rings (B) any more than necessary when installing.



RW25739-UN: Expander O-Ring

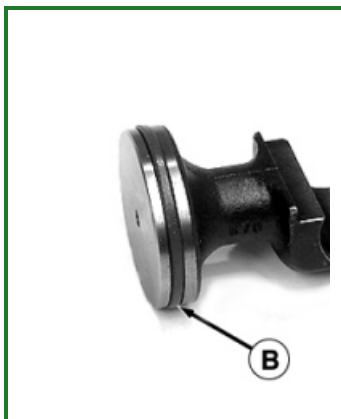

RW25740-UN: Seal Ring

LEGEND:

A - O-Ring

B - Seal Ring

Replace expander O-ring (A) on each end of servo piston.

43. Install seal ring (B) over O-ring on each end of piston.

44. IMPORTANT:

Bearing cage wears patterns in bearing race and swash plate. Components must be installed in proper

position with original orientation.

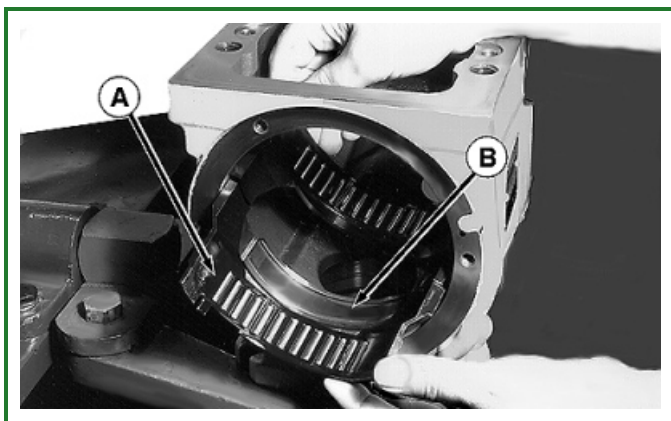

RW25741-UN: Swashplate Bearing Cage and Bearing Races

LEGEND:

A - Bearing Cage (2 used)

B - Bearing Race (2 used)

Tag or identify swash plate bearing cage positions to aid in proper assembly.

45. Remove and inspect swash plate bearing cage (A). Replace as required.

46. Tag or identify bearing race positions to aid in proper assembly.

47. Remove and inspect the two bearing races (B). Replace as required.

48. IMPORTANT:

Parts have critical, high tolerance surfaces which require careful handling to prevent damage.

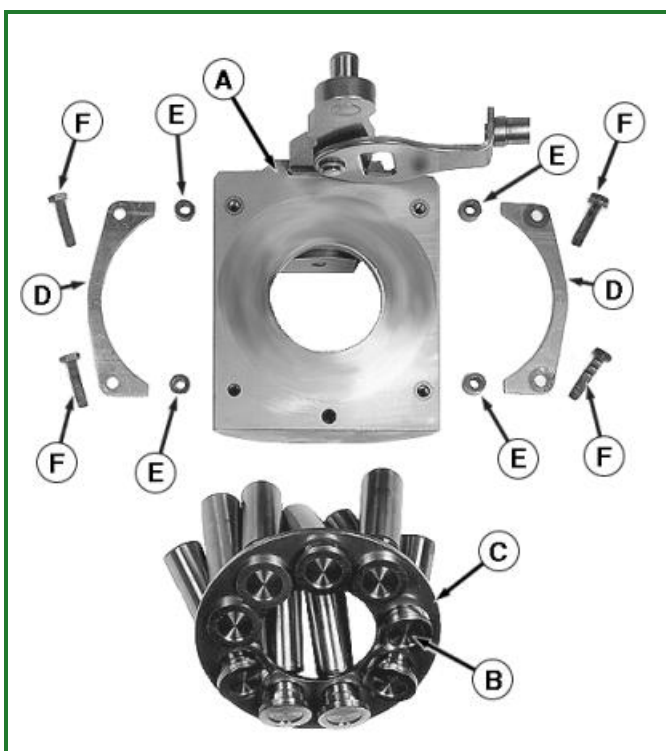

T121170-UN: Disassemble swash plate and Piston Assembly

LEGEND:

- A - Swashplate
- B - Piston Assembly (9 used)
- C - Slipper Guide
- D - Slipper Guide Bearing (2 used)
- E - Spacer (4 used)
- F - Cap Screw (4 used)

Disassemble and inspect parts (A—E) discarding cap screws (F).

49. IMPORTANT:

Servo arm alignment is critical. Do not remove servo arm (A) from swash plate unless replacing.

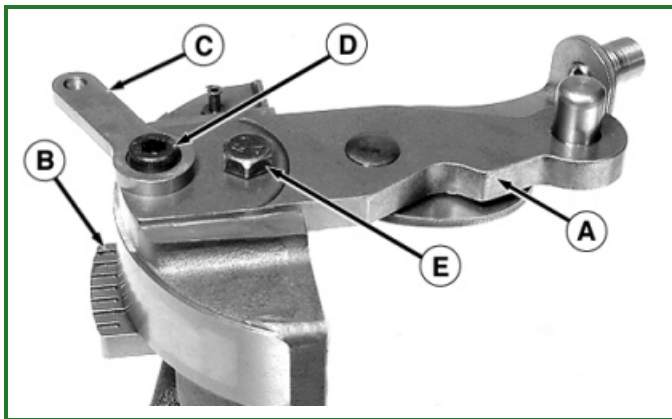

RW25742-UN: Servo Arm, Feedback Link and swash plate Guide

LEGEND:

- A - Servo Arm
- B - Swashplate Guide
- C - Feedback Link
- D - Socket Head Cap Screw
- E - Cap Screw

Remove feedback link (C) by removing socket head cap screw (D).

50. Inspect swash plate guide (B).

51. Remove cap screw (E) only if replacement of servo arm is needed.

52.

NOTE:

Servo arm is a press fit.

Install new servo arm carefully aligning the slot and threaded holes in swash plate. Arm must be pressed completely into swash plate slot.

53. Install servo arm cap screw (E) and tighten to specifications.

Item	Measurement	Specification
Hydrostatic Pump		
Swashplate Servo Arm Cap Screw	Torque	32 N·m 24 lb-ft

54. Install feedback link (C) and swash plate guide (B). Tighten socket head cap screw (D) to specifications.

Item	Measurement	Specification
Hydrostatic Pump		
Swashplate Feedback Link Cap Screw Torque		32 N·m 24 lb-ft

55. IMPORTANT:

Threaded holes in swash plate and pump housing side cover opening must be cleaned of old locking compound prior to reassembly.

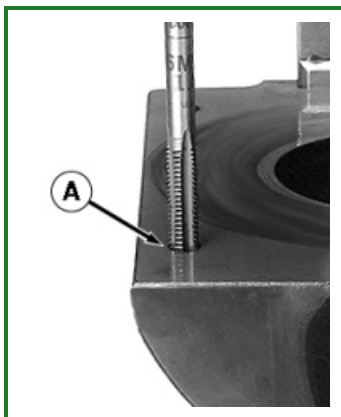

RW25729-UN: Swashplate

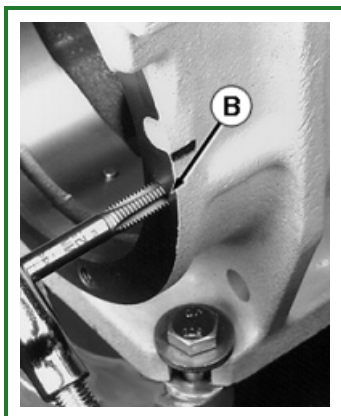

RW25744-UN: Pump Housing Side Cover Opening

LEGEND:

A - M6 Threaded Holes in Swashplate

B - M8 Threaded Holes in Housing

Clean the threaded holes in the swash plate (A) and pump housing side cover opening (B) using the correct tap.

56. IMPORTANT:

Pump housing must be clear of any contamination before assembling pump.

Clean inside of pump housing eliminating any excess thread locking compound or other contamination.

Go to [Section_03:Group_0360](#)

TE14778,0000040-19-20100622

Hydrostatic Charge Pump Disassemble and Assemble

IMPORTANT:

Absolute cleanliness is essential when working on hydrostatic components.

1. Remove socket head cap screws (1), adapter (2) and O-ring.



T199994A-UN: Remove Adapter Plate

LEGEND:

- 1 - Socket Head Cap Screw (4 used)
- 2 - Adaptor Plate

2. Remove cap screws (3) and retaining plate (4).

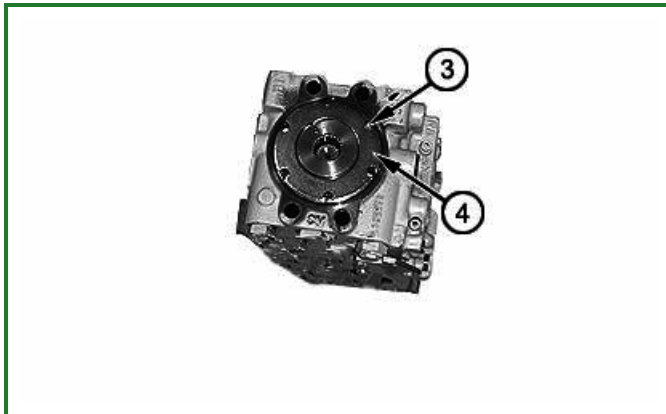

T199995A-UN: Pump Retaining Screws

LEGEND:

- 3 - Cap Screw (6 used)
- 4 - Retaining Plate

3. IMPORTANT:

Wear patterns develop between pump gerotor assembly (5) and eccentric ring (6). Components must be installed in proper position with original orientation.

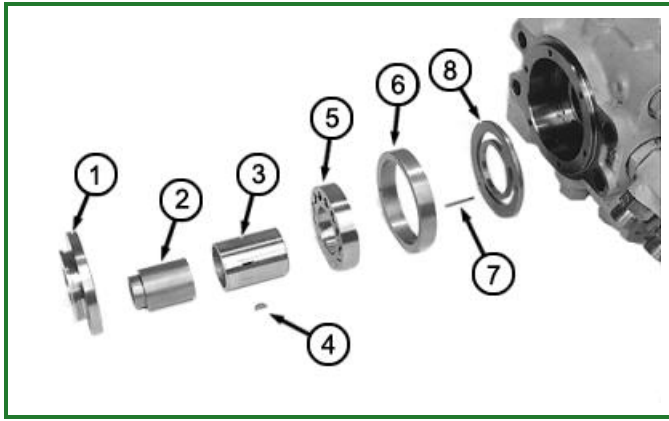

T199996A-UN: Charge Pump Cover-to-Port Layout

LEGEND:

- 1 - Charge Pump Cover
- 2 - Auxiliary Drive Coupling
- 3 - Charge Pump Shaft
- 4 - Key
- 5 - [Charge Pump Gerotor Assembly Serviced as an assembly]
- 6 - [Eccentric Ring Serviced as an assembly]
- 7 - Alignment Pin
- 8 - Port Plate

Tag or identify visible side of pump gerotor assembly (5) and eccentric ring (6) to aid in proper assembly.

4. Remove and inspect parts (1—8) and replace as required.
5. Remove bushing from charge pump cover (1).
6. Clean all parts and lightly apply clean hydraulic oil.
7. **IMPORTANT:**

Charge pump rotation is determined by the orientation of eccentric ring in the gerotor assembly, and the location of the alignment pin (1). Incorrect assembly will not provide charge oil to the pump and will result in damage to the pump.

NOTE:

One of the large socket head cap screws and four washers must be installed in the end cap, as illustrated, before assembling the charge pump.



T199997A-UN: Install Alignment Pin

LEGEND:

- 1 - Alignment Pin
- 2 - Port Plate

Install charge pump alignment pin (1) in the right rotation hole as illustrated.

8. Install port plate (2).

9. IMPORTANT:

Wear patterns develop between pump gerotor gears (3) and eccentric ring (1). Components must be installed in proper position with original orientation.

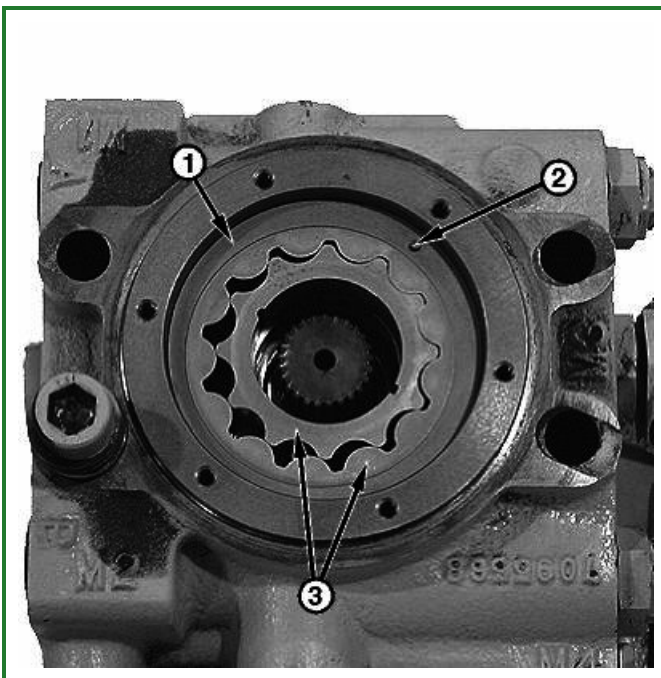

T119171B-UN: Eccentric Ring Alignment Pin and Gears

LEGEND:

- 1 - Eccentric Ring
- 2 - Alignment Pin
- 3 - Gerotor Gears

Install the eccentric ring (1) making sure alignment pin (2) is correctly installed.

10. Install the gerotor gears (3).

11.

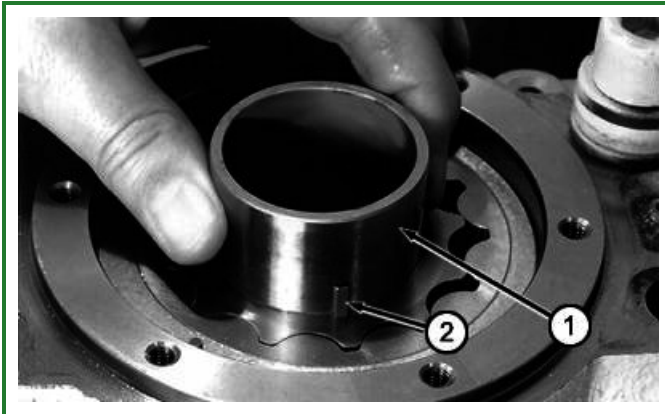

T199993A-UN: Charge Pump Shaft and Key

LEGEND:

1 - Pump Shaft

2 - Key

Install charge pump shaft (1) with key (2) aligning with slot in gerotor gear.

12.



T119593B-UN: Auxiliary Drive Coupling

LEGEND:

1 - Auxiliary Drive Coupling

Install auxiliary drive coupling (1).

13.

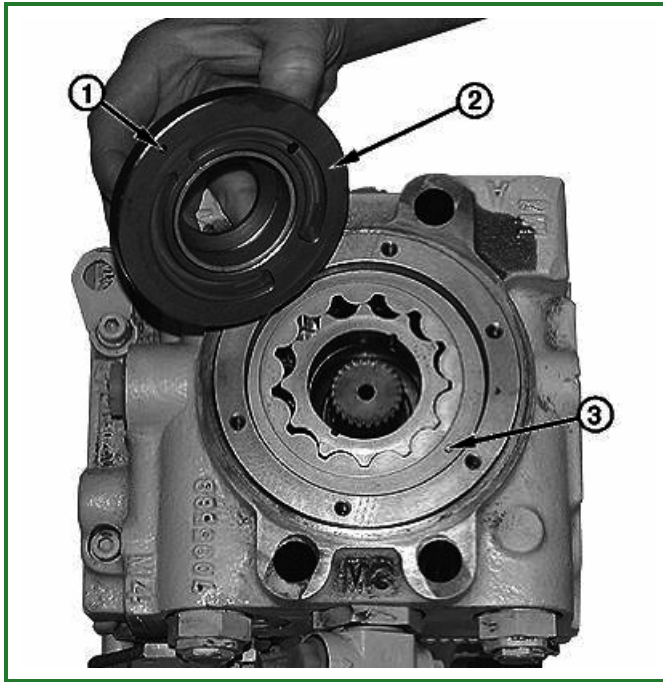

T119172B-UN: Charge Pump Cover, Hole & Alignment Pin

LEGEND:

- 1 - Hole in Cover
- 2 - Charge Pump Cover
- 3 - Alignment Pin

Install bushing in charge pump cover.

14. Install charge pump cover (2) making sure hole (1) in cover aligns correctly with alignment pin (3).

15.

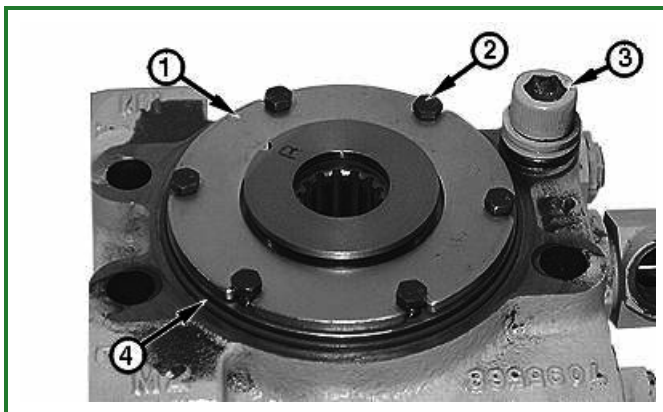

T119594B-UN: Retaining Plate

LEGEND:

- 1 - Retaining Plate
- 2 - Cap Screw (6 used)
- 3 - Socket Head Cap Screw and Washers
- 4 - O-Ring

Install retaining plate (1) and cap screws (2). Tighten to specifications.

Item	Measurement	Specification
Hydrostatic Pump		
Charge Pump Retaining Plate Cap Screws	Torque	14 N·m 120 lb-in.

16. Lubricate O-ring (4) with petroleum jelly and install.
17. Remove socket head cap screw and washers (3).
18. Install flange adapter (B).



T199994A-UN: Double Pump Adapter Plate

LEGEND:

- 1 - Socket Head Cap Screw and Washer (4 used)
- 2 - Flange Adapter

19. Install socket head cap screws and washers (1). Tighten to specifications.

Item	Measurement	Specification
Hydrostatic Pump		
Flange Adapter/End Cap-to-Hydrostatic Pump	Torque	298 N·m 220 lb-ft

20. Install pumps and calibrate transmission control unit (TCU). See [Transmission Control Unit \(TCU\) Calibration](#) . (Group 9015.)

Go to [Section_03:Group_0360](#)

CED,OUO1008,146-19-20040514

Pump Displacement Control Valve (PDCV) Disassemble and Assemble

1. IMPORTANT:

Hydrostatic pump displacement control valve (PDCV) is serviced as an assembly. Replace if damaged. Disassemble for cleaning purposes only.

Absolute cleanliness is essential when working on hydraulic components.

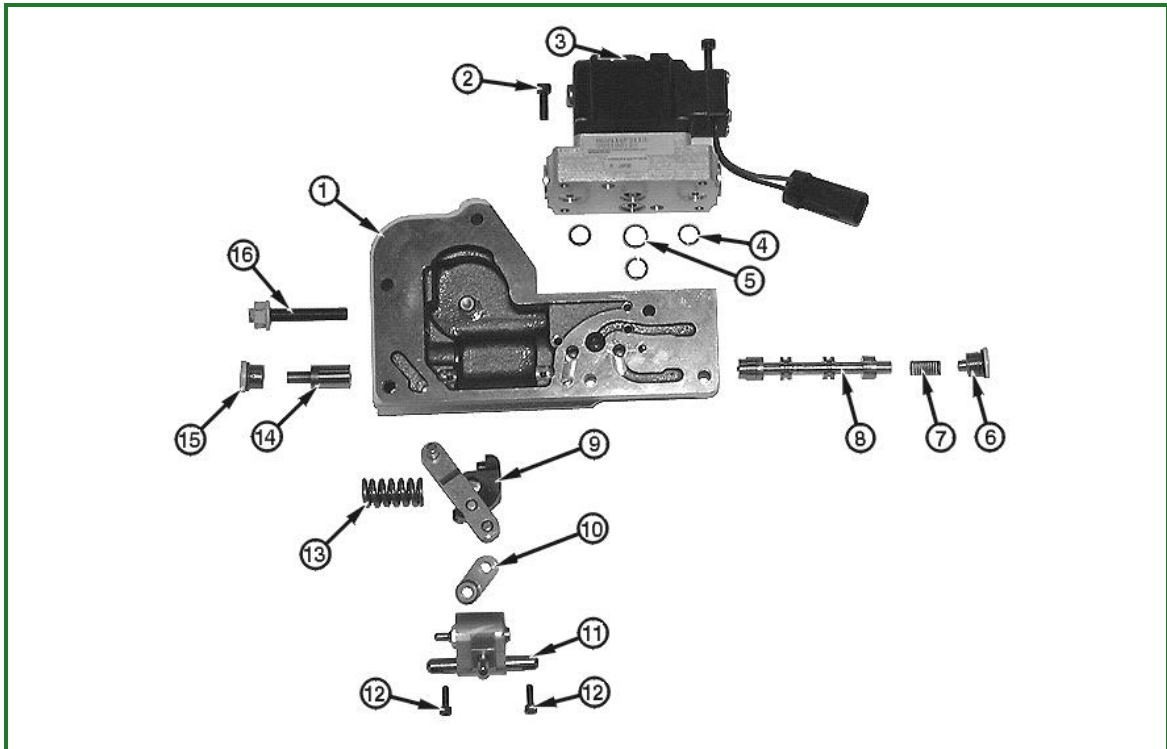

T199990A-UN: Exploded View

LEGEND:

- 1 - Control Valve Housing
- 2 - Cap Screw (4 used)
- 3 - Pressure Control Pilot (PCP)
- 4 - O-Ring (3 used)
- 5 - O-Ring (1 used)
- 6 - Cap
- 7 - Spring
- 8 - Valve Spool
- 9 - Feedback Link
- 10 - Link Arm
- 11 - Override Linkage Assembly
- 12 - Cap Screw (2 used)
- 13 - Spring
- 14 - Valve Spool
- 15 - Cap
- 16 - Adjustment Screw

Remove the six socket head cap screws and pump displacement control valve (PDCV) from the pump housing.

2.

NOTE:

The Pressure Control Pilot (PCP) (3) is serviced as an assembly. DO NOT disassemble.

Remove cap (15) and valve spool (14). Replace O-ring.

3. Remove cap (6), spring (7), and valve spool (8). Replace O-ring.
4. Loosen adjusting screw (16) to release tension on spring (13).
5. Remove caps screws (12).
6. Lift linkage assembly (9, 10 and 11) with spring from housing.

7.

NOTE:
Override linkage assembly (11) is not repairable. Do not disassemble.

Clean and inspect parts.

8. Assemble parts (9—13).
9. Install valve spools, spring, O-rings and caps. Tighten caps to specifications.

Item	Measurement	Specification
Hydrostatic Pump		
EDC Valve Spool Caps	Torque	11 N·m 96 lb-in.

10. Install new O-rings and Pressure Control Pilot (PCP). Tighten cap screws (2) to specifications.

Item	Measurement	Specification
Hydrostatic Pump		
Electronic Displacement Control-to-Control Valve Cap Screws	Torque	5.4 N·m 48 lb-in.

11. **IMPORTANT:**

If system has been contaminated with debris, the screen filter (E) must be removed for cleaning of associated parts. Screen filters are not reusable, replace after removal, see parts catalog for replacement parts.

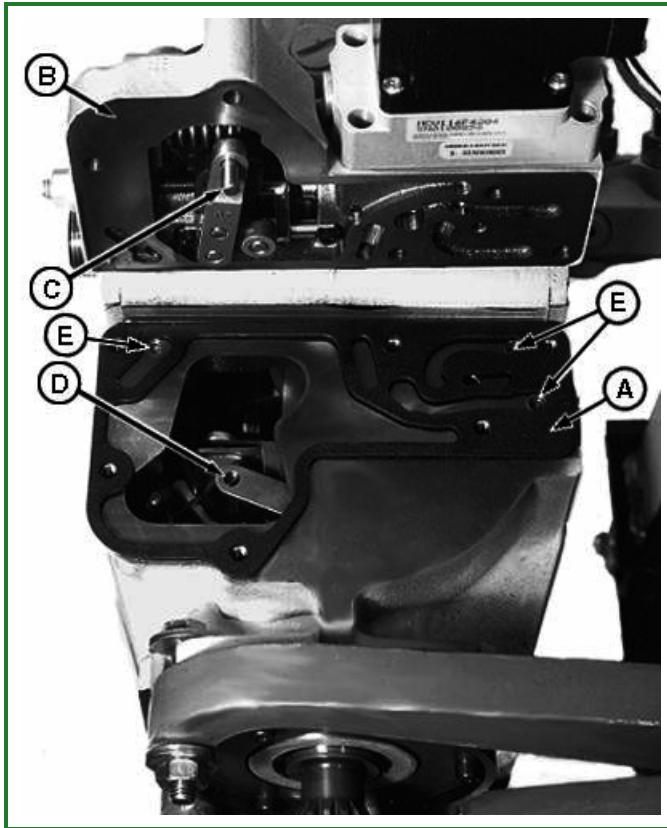

TX1012687A-UN: Control Valve, Pin and Feedback Link

LEGEND:

- A - Gasket
- B - Displacement Control Valve
- C - Feedback Linkage Pin
- D - Feedback Link
- E - Screen Filter (3 used)

Inspect and clean screen filters (E) before installing displacement control valve (B).

12. Install gasket (A).

13. IMPORTANT:

Linkage pin (C) must be installed correctly into link (D) or swash plate will not move.

Install displacement control valve (B) to pump making sure neutral feedback linkage pin (C) installs correctly into feedback link (D).

14. Install and tighten the six cap screws to specifications.

Item	Measurement	Specification
Hydrostatic Pump		
Displacement Control Valve-to-Hydrostatic Pump Cap Screws	Torque	16 N·m 144 lb-in.

15.

⚠ CAUTION:

After the displacement control valve has been disassembled, the tracks could rotate when park lock lever is lowered until null adjustment is performed.

Perform pump displacement control valve neutral adjustment. [See Pump Displacement Control Valve \(PDCV\) Neutral \(Null\) Adjustment . \(Group 9026.\)](#)

16. Calibrate transmission control unit (TCU). [See Transmission Control Unit \(TCU\) Calibration . \(Group 9015.\)](#)

Go to [Section_03:Group_0360](#)

CED,OUO1008,149-19-20100622

Multi-Function Valve Disassemble and Assemble

1.



T200000A-UN: Multi-Function Valves

LEGEND:

1 - Multi-Function Valve (2 used)

Remove multi-function valves (1) from end cap.

2.

⚠ CAUTION:

Multi-function valves contain springs under compression. Release spring tension by turning adjusting screw counter clockwise.

Use a small screw driver to separate multi-function valve body from poppet assembly.



T118409B-UN: Disassemble Multi-Function Valve

3.

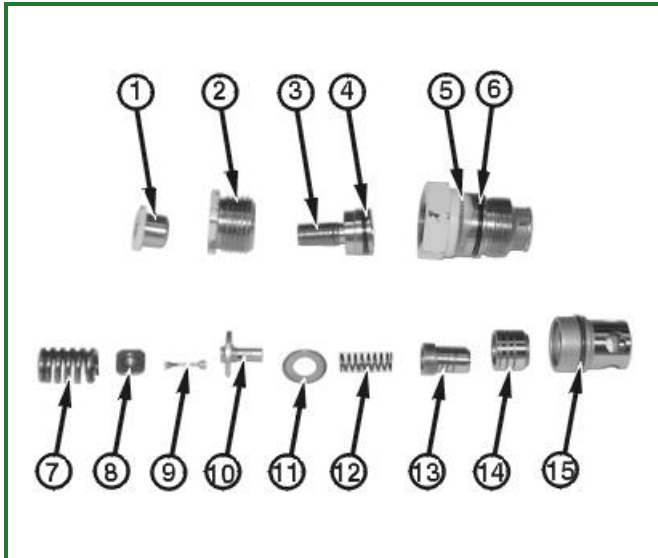
**T119706B-UN: Exploded View Multi-function Valve****LEGEND:**

- 1 - Lock Nut
- 2 - Cap
- 3 - Bypass Piston
- 4 - O-Ring
- 5 - Valve Housing
- 6 - O-Ring
- 7 - Spring
- 8 - Spring Guide
- 9 - Pressure Limiter Poppet
- 10 - Guide
- 11 - Washer
- 12 - Spring
- 13 - High Pressure Relief Valve Poppet
- 14 - Check Valve Poppet
- 15 - O-Ring

Carefully loosen cap (2) to release pressure on springs (7 and 12). Disassemble valve as shown.

4. Clean valve components and check for any contamination.

5. **NOTE:**

Other than O-rings, multi-function valve components are not serviceable.

If any valve components are damaged, replace the entire valve.

6. Lubricate valve components with clean hydraulic oil.

7. Assemble multi-function valve. Use a vise to carefully press poppet assembly onto valve body. Tighten lock nut (1) to specification.

Item	Measurement	Specification
Multi-Function Valve Lock Nut	Torque	16.3 N·m 144 lb-in.

8. Check valve poppet movement in end of the multi-function valves.
9. Install and tighten multi-function valves to specifications.

Item	Measurement	Specification
Hydrostatic Pump		
Multi-Function Valves	Torque	79 N·m 58 lb-ft

10. Perform multi-function relief valve test. (See [Multi-Function Relief Valve Test](#) . (Group 9026.)
11. Calibrate transmission control unit (TCU). See [Transmission Control Unit \(TCU\) Calibration](#) . (Group 9015.)

Go to [Section_03:Group_0360](#)

CED,OUO1004,521-19-20040514

Neutral Charge Relief Valve Disassemble and Assemble

1.

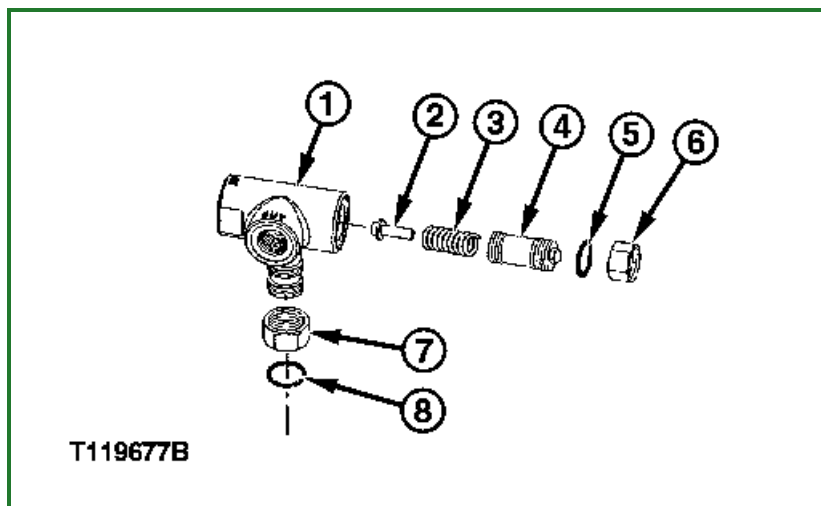
**T119677B-UN: Charge Relief Valve****LEGEND:**

- 1 - Valve Housing
- 2 - Poppet
- 3 - Spring
- 4 - Adjusting Screw
- 5 - O-Ring
- 6 - Lock Nut
- 7 - Lock Nut
- 8 - O-Ring

Disconnect lines and remove relief valve from bottom of front hydrostatic pump. Note orientation of valve to aid in assembly.

2. Remove parts (2—8). Clean and inspect all parts for wear or damage.
3. Install new O-rings and assemble valve.
4. **Perform Neutral Charge Relief and Operating Charge Relief Pressure Test . (Group 9026.)**

Go to [Section_03:Group_0360](#)

CED,OUO1004,523-19-20040514

Hydrostatic Pump Assemble

1.

NOTE:

Apply clean hydrostatic oil to all internal parts before assembly

IMPORTANT:

Components must be installed in proper position with original orientation to prevent premature pump failure. Bearing races must be completely seated in housing.

Inspect bearing cage wear patterns in bearing race and swash plate to determine remaining service life.

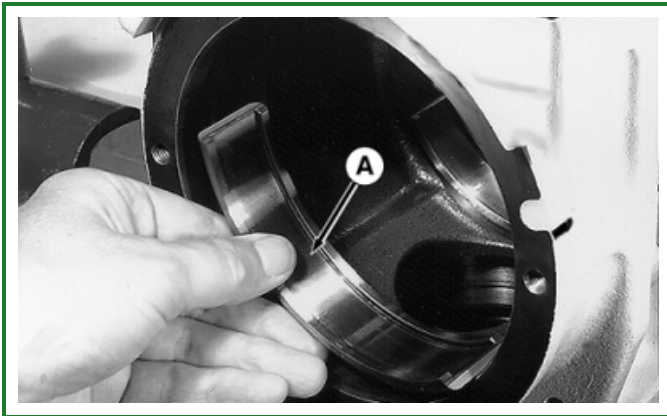
**RW25758-UN: Installing Bearing Races****LEGEND:**

A - Bearing Race (2 used)

Install bearing races (A) in housing.

2. Lubricate and install bearing cage on the bearing races.

3. **IMPORTANT:**

Damage to polished surfaces can cause premature pump failure. Be careful when handling parts with polished surfaces to prevent nicks or scratches.

NOTE:

Either side of slipper guide can be installed against slippers. Flip slipper guide if excessive wear is on top bearing surface.

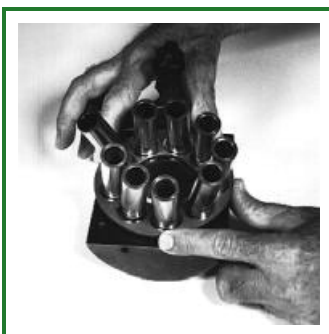

T8464BL-UN: Piston Assemblies

Inspect slipper guide surface, install smoothest side away from slippers.

Clean slipper guide bearing screw holes on swash plate surface using M8 tap.

4.

NOTE:

Apply clean hydrostatic oil to all internal parts before assembly.

Install the piston assemblies into the slipper guide.

5. Apply clean hydrostatic oil on slippers. Center the pistons and guide on the swash plate.

6. **IMPORTANT:**

For correct assembly and to prevent premature wear, slipper guide bearing must be installed as shown.

The split between the slipper guide bearing plates must be located in line with the swash plate arm. The TEFLON® surface side of slipper guide bearing must be installed against the slipper guide.

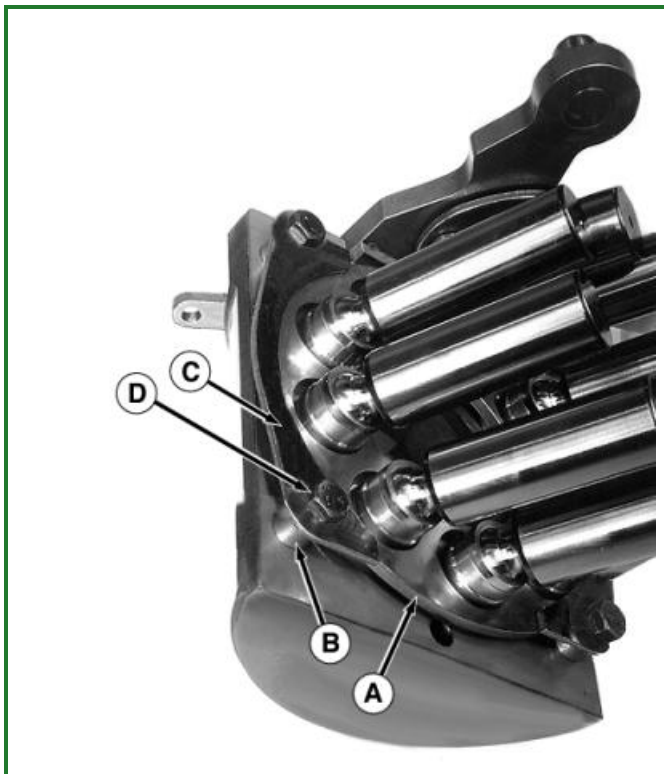

T121169-UN: Slipper Guide Bearings, Spacers & Screws

LEGEND:

A - Slipper Guide

B - Spacer (4 used)

C - Slipper Guide Bearing (2 used)

D - Cap Screw (4 used)

Install first slipper guide bearing plate (C) with TEFLON® surface against the slipper guide (A) as shown.

7. **IMPORTANT:**

To prevent premature pump failure, new slipper guide bearing plate cap screws must be installed. Install

new cap screws whenever slipper guide bearing plates are removed.

Apply PM37418 thread lock and sealer (medium strength) on cap screw threads. Install new cap screws (D) through the slipper guide bearing and spacers (B) as shown. Finger tighten the cap screws into the swash plate.

8.

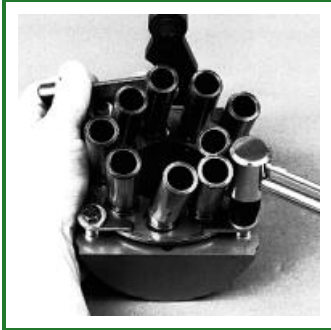

T8464BQ-UN: 750J Slipper Guide Assembly Shown

Tighten slipper guide bearing cap screws to specification.

Check movement of the assembly by hand. The slipper guide and piston slippers must slide freely on the swash plate.

Item	Measurement	Specification
Hydrostatic Pump Swash Plate-to-Slipper Guide Bearing		
Cap Screw	Torque	13.5 N·m 120 lb-in.

9. Lubricate the pistons and cylinder block bores in clean hydraulic oil.

10. IMPORTANT:

Wear patterns develop between cylinder block bores and pistons. Pistons must be installed in original cylinder block bores.

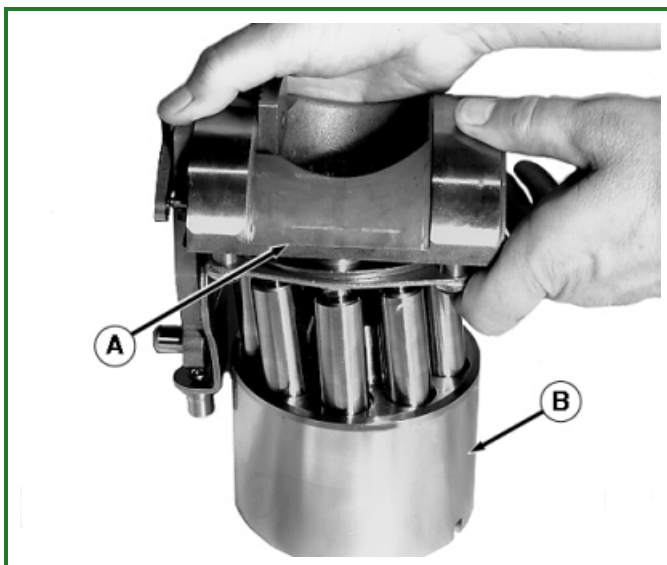

RW25746-UN: Swash Plate/Piston Assemblies and Cylinder Block

LEGEND:

A - Swash Plate and Piston Assembly

B - Cylinder Block

Align pistons with original cylinder block bores and install assembly (A) in cylinder block (B).

11. IMPORTANT:

Wear patterns develop between servo pistons and servo cylinders. Servo piston must be installed with original orientation.

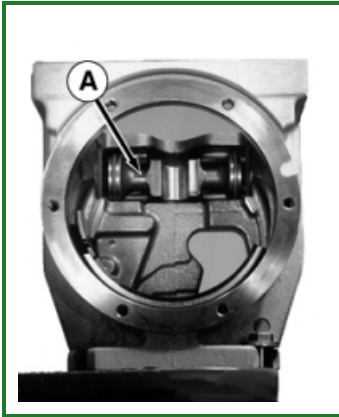

RW25747-UN: Servo Piston

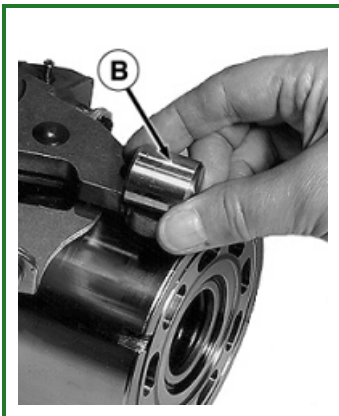

RW25748-UN: Bronze Slider Block

LEGEND:

A - Servo Piston

B - Slider Block

Install servo piston (A) into pump housing.

12. Install bronze slider block (B) onto servo arm of swash plate assembly.

13.

NOTE:

A second person will be needed to help align the slider block into the servo piston during swash plate installation.

A cap screw approximately 229 mm (9 in.) long, two flat washers 63 mm (2.5) OD and nut should be used to assist in lowering cylinder block into housing.

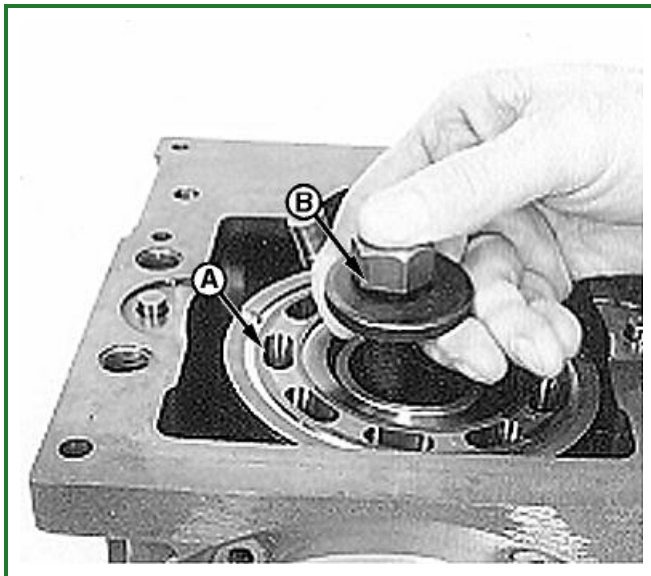

T118276-UN: Cap Screw Assembly Tool

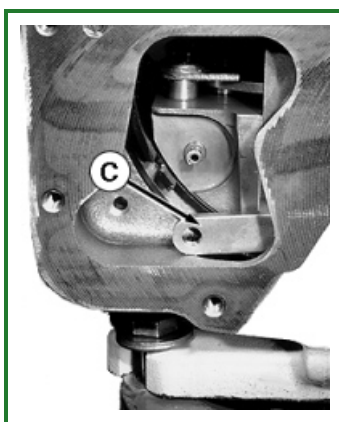

RW25754-UN: Feedback Link

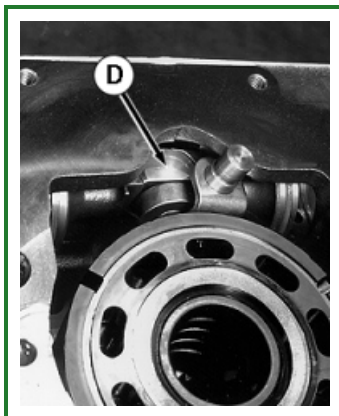

RW25755-UN: Slider Block

LEGEND:

- A - Piston Assembly
- B - Assembled Cap Screw Tool
- C - Feedback Link
- D - Bronze Slider Block

Lower swash plate and piston assembly partially into the pump housing.

14. Hold the assembly above the cradle bearings to correctly position the feedback link (C) in the control opening.
15. Align slider block (D) into the servo piston and continue to lower swash plate assembly into position on

the bearings.

16. Remove the cap screw and washer used for cylinder block installation.
17. Check for clearance between the servo arm and slider block (D). If no clearance exists, recheck the assembly of the bearing cage and races.
18. Check to make sure swash plate assembly and servo piston slide freely.
19. Lubricate each of the internal bores of the servo cylinder with clean hydraulic oil.
20. Install O-rings on servo cylinder.
21. IMPORTANT:
Wear patterns develop between servo pistons and servo cylinders. Servo cylinders must be installed in original positions.

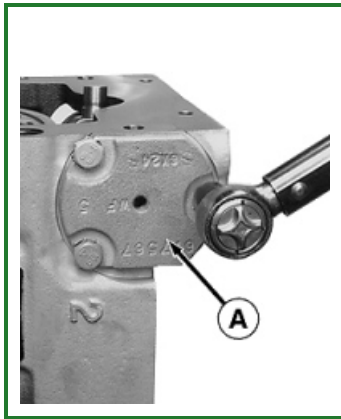

RW25756-UN: Servo Cylinder

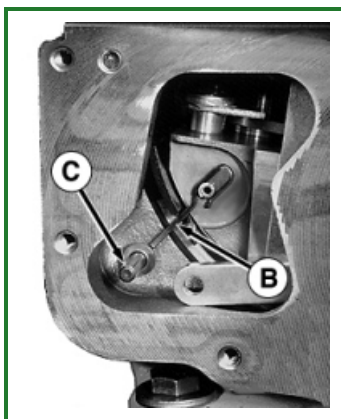

RW25757-UN: Cage Locator Link and Locator Link Pin

LEGEND:

- A - Servo Cylinder
- B - Locator Link
- C - Locator Link Pin

Hold the servo piston in position and install the servo cylinders (A) into original bores.

22. Tighten the servo cylinder cap screws to specifications.

Item	Measurement	Specification
Hydrostatic Pump		
Servo Cylinder Cap Screws	Torque	33 N·m 24 lb-ft

23. Move the swash plate to align the spring pin in the swash plate with the slot in the swash plate bearing cage and the pin hole in the housing.
24. Install cage locator link (B) and locator link pin (C).
25. IMPORTANT:
T-Bar must be positioned on top of swash plate.

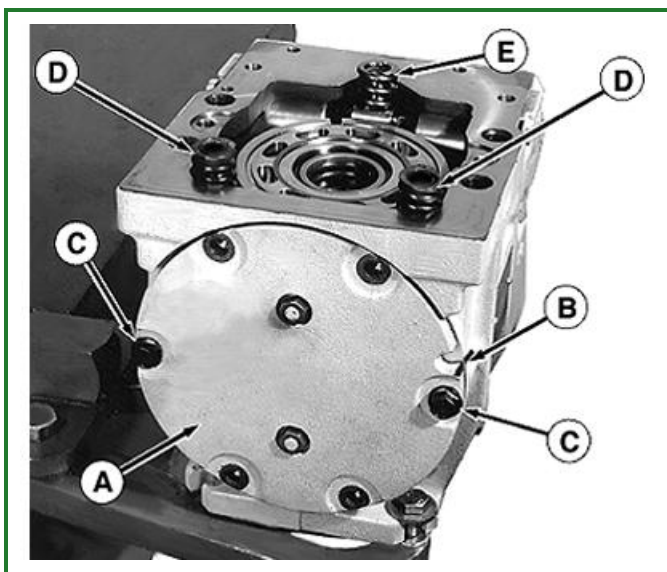

T156777B-UN: Side Cover Alignment Marks

LEGEND:

- A - Side Cover
- B - Alignment Mark
- C - Cap Screw (2 used)
- D - Swash Plate Leveling Spring (2 used)
- E - Swash Plate Hold-Down Spring

Install O-ring on side cover.

26. Install side cover (A) to pump housing making sure O-ring is not damaged during installation.
27. Align side cover and pump housing with mark (B).
28. Install two new cap screws (C) as illustrated to hold cover. Do not fully tighten the cap screws.
29. Install leveling springs (D) and swash plate hold-down spring (E).

30.

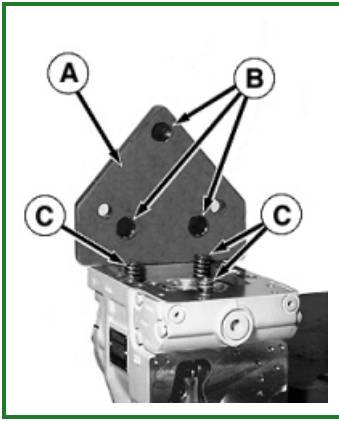

RW25760-UN: Leveling Plate, Spring Pockets & Springs

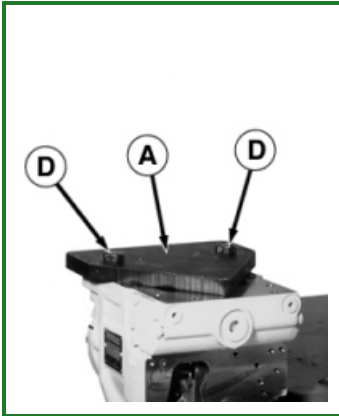

RW25761-UN: JDG1094 Leveling Plate and Cap Screws

LEGEND:

- A - JDG1094 Leveling Plate
- B - Spring Pocket (3 used)
- C - Leveling Spring (3 used)
- D - Cap Screw (2 used)

Install JDG1094 Leveling Plate (A) to pump housing making sure spring pockets (B) are correctly aligned with springs (C).

31. Install and tighten cap screws (D).

32. IMPORTANT:

The base of the depth micrometer must be positioned on top of the JDG1094 Leveling Plate when measuring zero angle position of the swash plate.

The rod must be located on the swash plate and NOT on the piston retainer plate.

NOTE:

Depth gauge must have capability of measuring approximately 100—127 mm (4—5 in.).

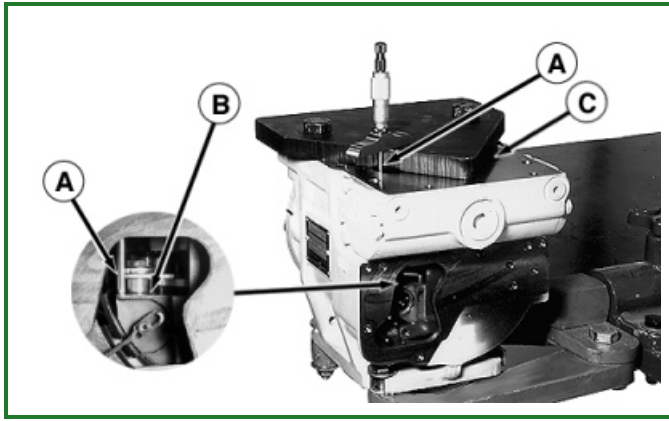

RW25762-UN: Measure Depth

LEGEND:

A - Depth Micrometer

B - Swash Plate Flat Surface

C - Opposite Measuring Location

Measure the zero angle position of the swash plate using a depth micrometer as illustrated making sure the end of the micrometer rod (A) is contacting the swash plate flat surface (B).

33. Measure the other side of swash plate at (C).

34. IMPORTANT:

Measurements must not vary more than 0.025 mm (0.001 in.) on either side of the swash plate.

Take a second measurement on each side.

35.

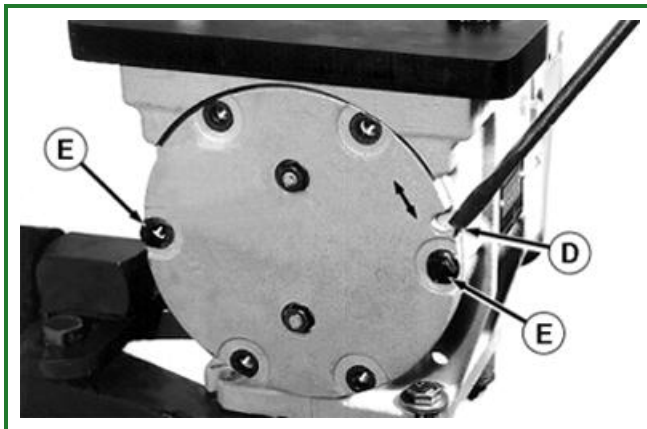

T118274-UN: Move Side Cover for Zero Angle

LEGEND:

D - Side Cover Rotation

E - Cap Screw (4 used)

Rotate the side cover at location (D) as necessary to obtain zero angle position of swash plate.

36. Once zero angle position has been established. Tighten the two side cover screws (E) to specifications.

Item	Measurement	Specification
Hydrostatic Pump		
Side Cover-to-Pump Housing Blind Hole Cap Screws	Torque	33 N·m 24 lb-ft

37. Install the remaining new four side cover cap screws to specifications.

Item	Measurement	Specification
Hydrostatic Pump		
Side Cover-to-Pump Housing Through (Top Two) Hole Cap Screws	Torque	33 N·m 24 lb-ft

38. Recheck zero angle position to verify side cover did not move while torquing the four side cover cap screws (E).

39. Remove leveling plate.

40.

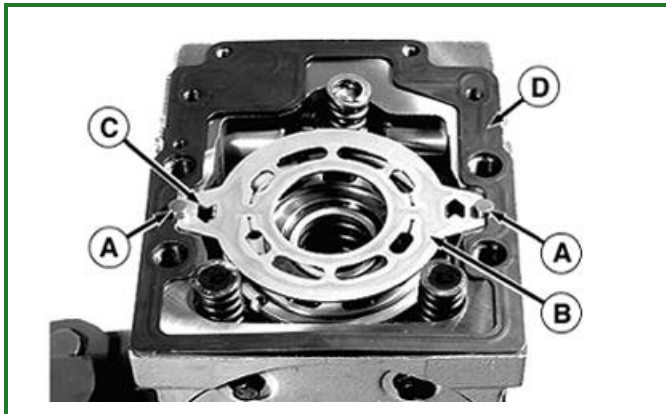

T156793B-UN: Direction of Arrows

LEGEND:

- A - Alignment Pin (2 used)
- B - Valve Plate
- C - Directional Arrow (2 used)
- D - Gasket

Install two alignment pins (A).

41. Lubricate the running surface of the cylinder block.

42.

NOTE:

Make sure valve plate (B) and gasket (D) do not get caught on alignment pins (A) during installation.

NOTE:

The arrow cut-outs in the valve plate must point in the direction of pump rotation when viewed from the shaft end.

Install valve plate (B) making sure the direction arrows (C) stamped in the valve plate are correctly positioned.

43. Install gasket (D).

44. IMPORTANT:

Use hardened swash plate leveler spring shims only. Using other materials for shims may result in damage to pump.

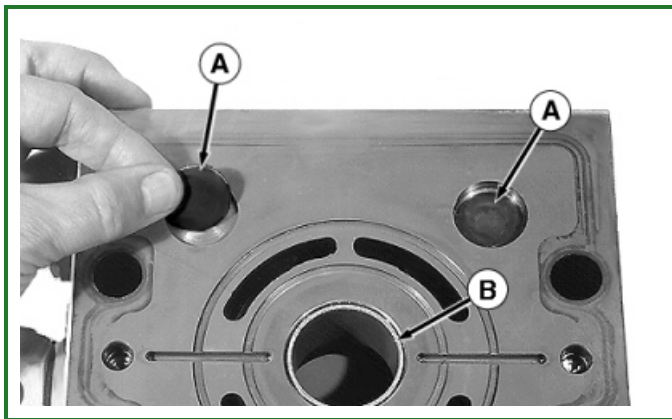

RW25765-UN: Installing Leveler Spring Shims

LEGEND:

- A - Leveler Spring Shim (2 used)
- B - End Cap Journal Bearing

Install the leveler spring shims (A) in the end cap pockets using petroleum jelly to hold shims.

45. Lubricate the end cap journal bearing (B) with clean hydraulic oil.

46.

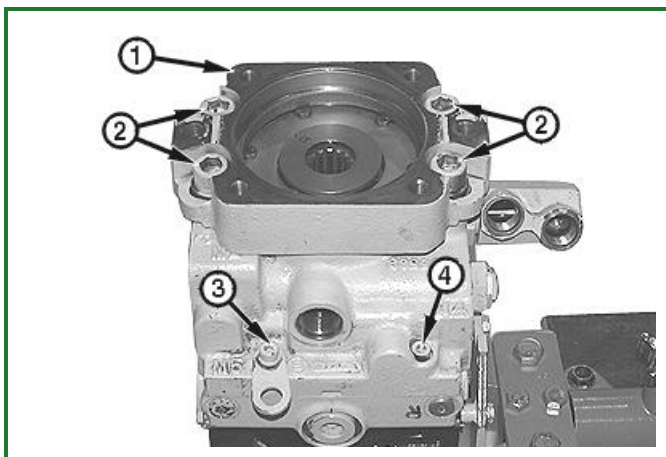

T119614B-UN: Washers and Hex Screws

LEGEND:

- 1 - Adapter Plate
- 2 - Socket Head Cap Screws (4 used)
- 3 - Socket Head Cap Screw with Spacer and Lift Bracket
- 4 - Socket Head Cap Screw

Install the end cap to the pump housing making sure springs align with the end cap pockets.

47. Install O-ring, new adapter plate (1), and socket head cap screws (2). Tighten cap screws to specifications.

Item	Measurement	Specification
Hydrostatic Pump		
End Cap/Adapter-to-Pump Cap Screws (Large)	Torque	298 N·m 220 lb-ft

48. Install socket head cap screw (3) with spacer and lifting bracket and cap screw (4). Tighten to specifications.

Item	Measurement	Specification
Hydrostatic Pump		
End Cap-to-Pump Cap Screws (Small)	Torque	33 N·m 24 lb-ft

- 49.



RW25767-UN: Installing Shaft and Bearing Assembly

Turn the pump 180° to install the shaft.

50. Install the shaft and bearing assembly.
 51. Rotate the shaft to insure the rotating assembly turns freely.

- 52.

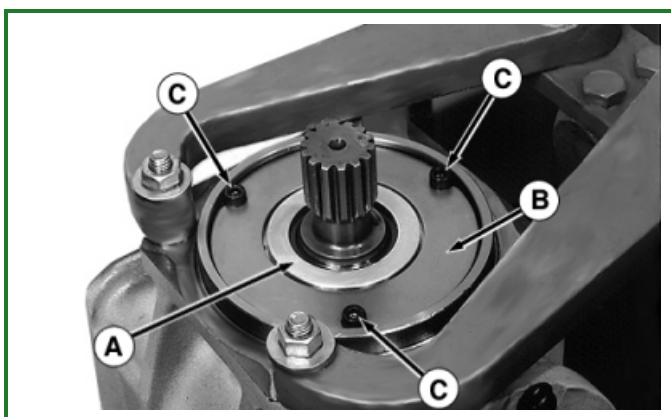

RW25768-UN: Seal Carrier, Retaining Plate and Screws

LEGEND:

- A - Seal Carrier
- B - Retaining Plate
- C - Socket Head Cap Screw (3 used)

Carefully install seal carrier (A) with lip seal.

53. Install retaining plate (B) and socket head cap screws (C). Tighten to specifications.

Item	Measurement	Specification
Hydrostatic Pump		
Input Shaft Seal Carrier Retaining Cap Screw	Torque	16 N·m 144 lb-in.

54. Install displacement control valve assembly. [See Pump Displacement Control Valve \(PDCV\) Disassemble and Assemble . \(Group 0360.\)](#)

Go to [Section_03:Group_0360](#)

TE14778,0000041-19-20100422

Hydrostatic Motor Disassemble

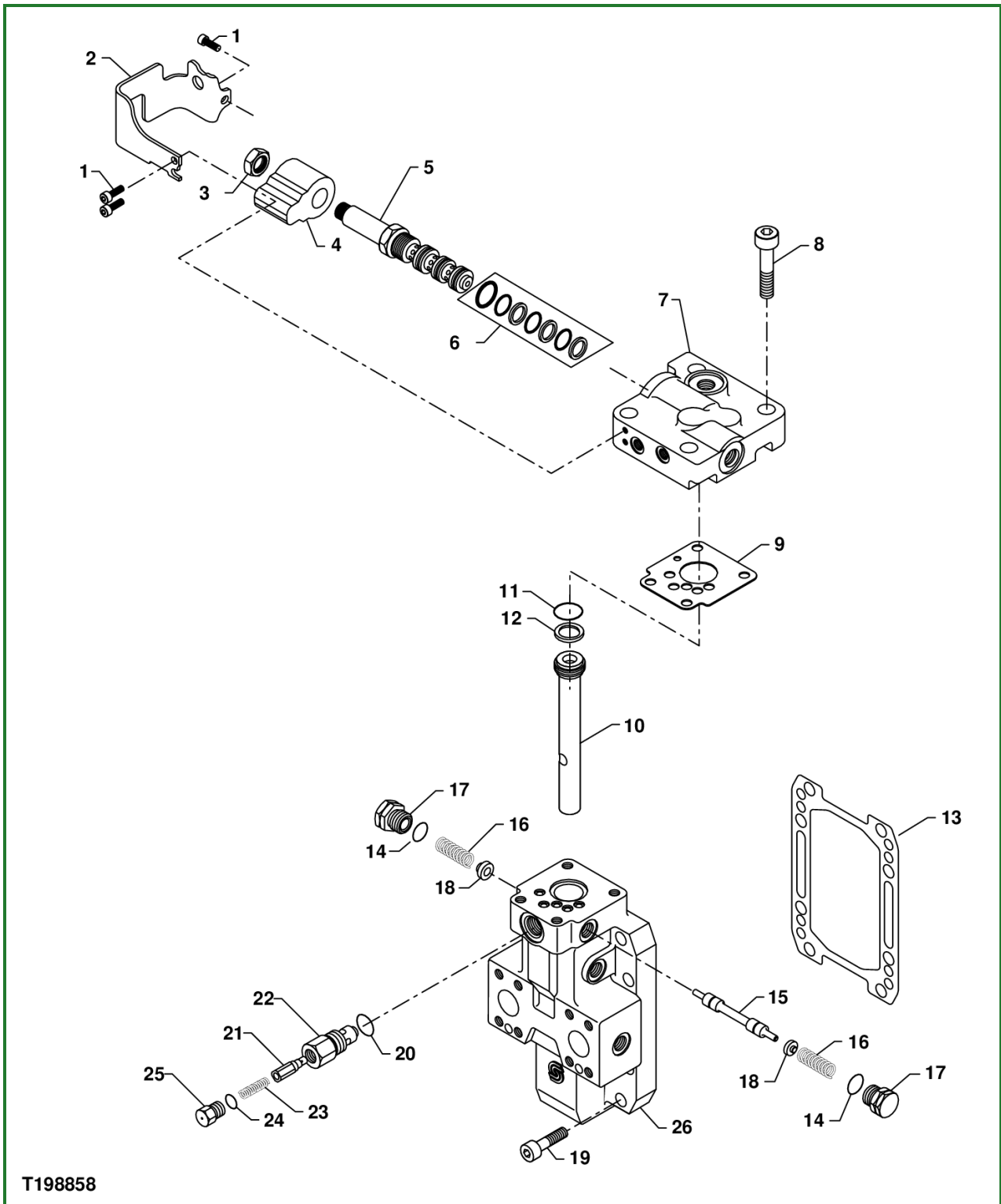

T198858

T198858-UN: Hydrostatic Motor Control Valve

LEGEND:

- 1 - Hex Socket Head Cap Screw (3 used)
- 2 - Bracket
- 3 - Nut
- 4 - Solenoid Valve Coil
- 5 - Solenoid Valve Spool
- 6 - Solenoid Valve O-ring Kit
- 7 - Solenoid Valve Housing
- 8 - Hex Socket Head Cap Screw (4 used)

- 9 - Gasket
- 10 - Servo Piston
- 11 - O-ring
- 12 - V-ring
- 13 - Gasket
- 14 - O-ring (2 used)
- 15 - Flushing Valve Spool
- 16 - Spring (2 used)
- 17 - Plug Fitting (2 used)
- 18 - Spring Plate (2 used)
- 19 - Hex Socket Head Cap Screw (8 used)
- 20 - O-ring
- 21 - Poppet Valve
- 22 - Operating Charge Relief Valve Housing
- 23 - Spring
- 24 - O-ring
- 25 - Plug Fitting
- 26 - End Cap Housing

1. Thoroughly clean external surface of motor prior to disassembly.
2. Scribe a line between hydrostatic motor control valve and rotating group housing to aid in assembly.
3. Remove eight hex socket head cap screws (19) and hydrostatic motor control valve from rotating group housing
4. Remove four hex socket head cap screws (8) and motor shift solenoid valve housing (7) from end cap housing (26).
5. Disassemble motor shift solenoid valve as shown.

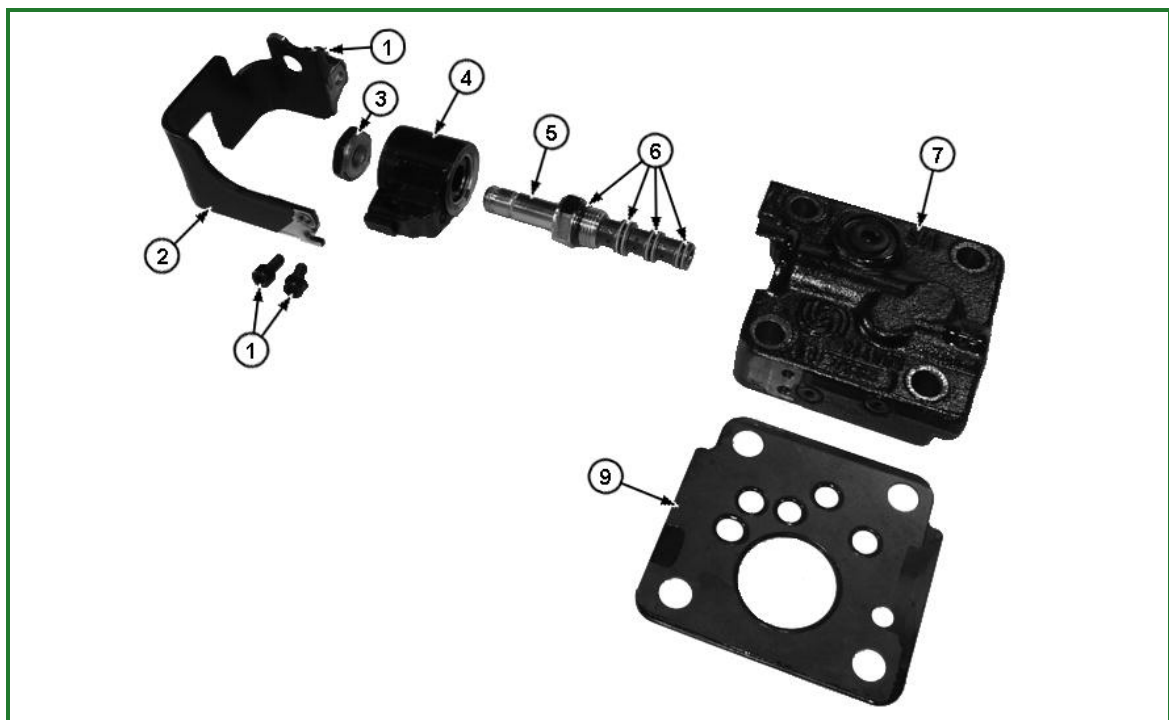

T19886A-UN: Solenoid Valve Assembly

LEGEND:

- 1 - Hex Socket Head Cap Screw (3 used)
- 2 - Bracket
- 3 - Nut
- 4 - Solenoid Valve Coil
- 5 - Solenoid Valve Spool
- 6 - Solenoid Valve O-ring Kit
- 7 - Solenoid Valve Housing
- 9 - Gasket

6. Disassemble solenoid valve O-ring kit (6) from solenoid valve spool.

7. Disassemble end cap assembly as shown.

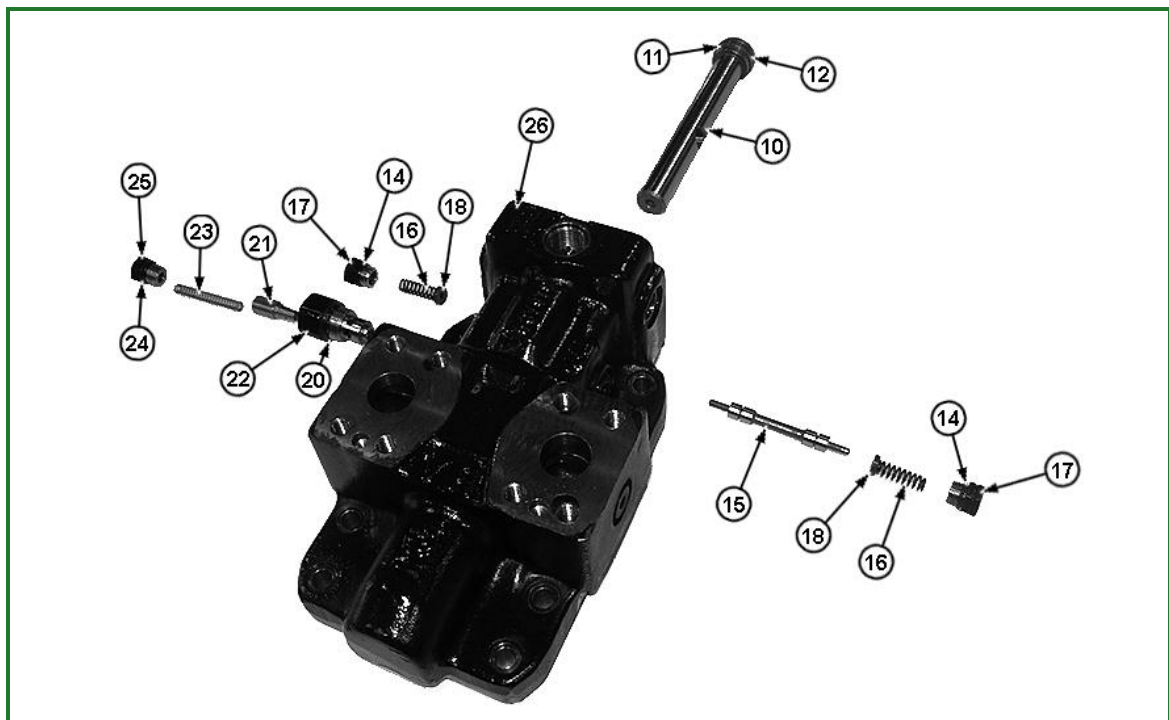

T198903A-UN: End Cap Assembly

LEGEND:

- 10 - Servo Piston
- 11 - O-Ring
- 12 - V-Ring
- 14 - O-Ring (2 used)
- 15 - Flushing Valve Spool
- 16 - Spring (2 used)
- 17 - Plug Fitting (2 used)
- 18 - Spring Plate (2 used)
- 20 - O-Ring
- 21 - Poppet Valve
- 22 - Operating Charge Relief Valve Housing
- 23 - Spring
- 24 - O-Ring
- 25 - Plug Fitting

8. IMPORTANT:

Special attention should be given to the orientation of the valve segment (41) with end cap and housing (26), cylinder block alignment pins (44), synchronizer shaft rollers (47) with synchronizer shaft (recess faces the centerline of the shaft) and synchronizer shaft (48) with cylinder block (45) and output shaft.

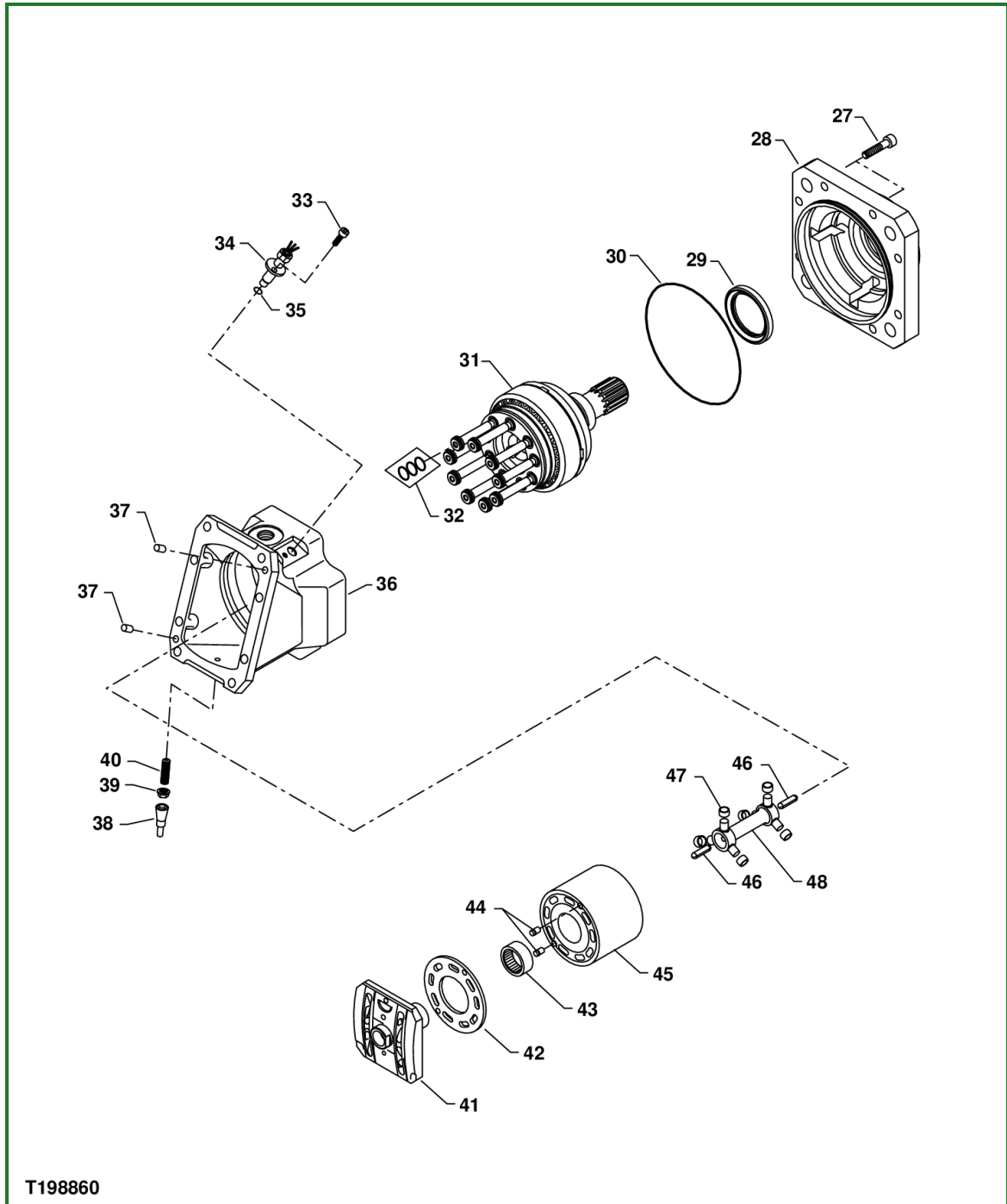

T198860-UN: Rotating Group Assembly

LEGEND:

- 27 - Hex Socket Head Cap Screw (8 used)
- 28 - Flange
- 29 - Seal
- 30 - O-ring
- 31 - Shaft Assembly
- 32 - Seal Kit

- 33 - Hex Socket Head Cap Screw
- 34 - Speed Sensor
- 35 - O-ring
- 36 - Rotating Group Housing
- 37 - End Cap Housing Alignment Pin (2 used)
- 38 - Cap
- 39 - Nut
- 40 - Set Screw
- 41 - Valve Segment
- 42 - Bearing Plate
- 43 - Cylinder Block Bearing
- 44 - Cylinder Block Alignment Pin (2 used)
- 45 - Cylinder Block
- 46 - Synchronizer Shaft Support Pin (2 used)
- 47 - Synchronizer Shaft Roller (6 used)
- 48 - Synchronizer Shaft

Remove hydrostatic motor parts (41—48).

- 9. Remove socket head cap screw (33) and motor speed sensor (34) from rotating group housing (36).
- 10. Scribe a line on housing and flange to aid in assembly. Remove eight socket head cap screws (27) from flange. Remove flange from rotating group housing.
- 11. Remove old seal (29) from flange. Once removed, the seal is not reusable.

12.



T199010A-UN: Shaft Assembly

Pull shaft assembly out of main housing, taking care not to damage the shaft and speed sensor ring. DO NOT damage pistons. Use attachments from the D01173AA 17-1/2 Ton Puller Set and JT01800 Driver Set.

13. Remove seal kit (32) from pistons using a small pair of retaining ring pliers and an O-ring pick.

14. IMPORTANT:

Remove speed ring ONLY if replacement is necessary.

DO NOT damage sealing surface of cylinder block.

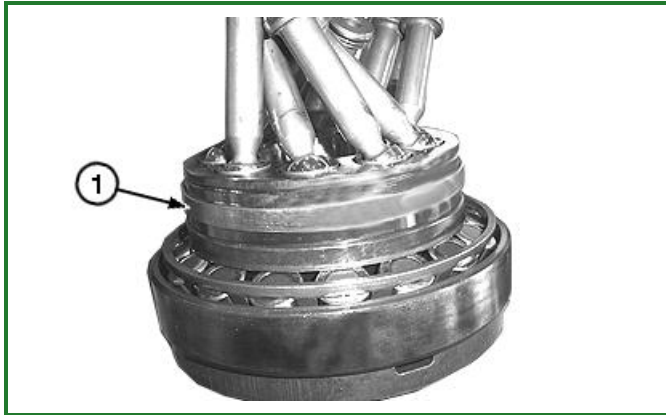

TX1012509A-UN: Shaft Assembly

LEGEND:

1 - Speed Ring

If required, remove speed ring (1) from shaft assembly by gently tapping on ring using a hammer and brass drift.

15. Clean and rotating group components. Replace as required.

Go to [Section_03:Group_0360](#)

TE14778,000001F-19-20061002

Hydrostatic Motor Assemble

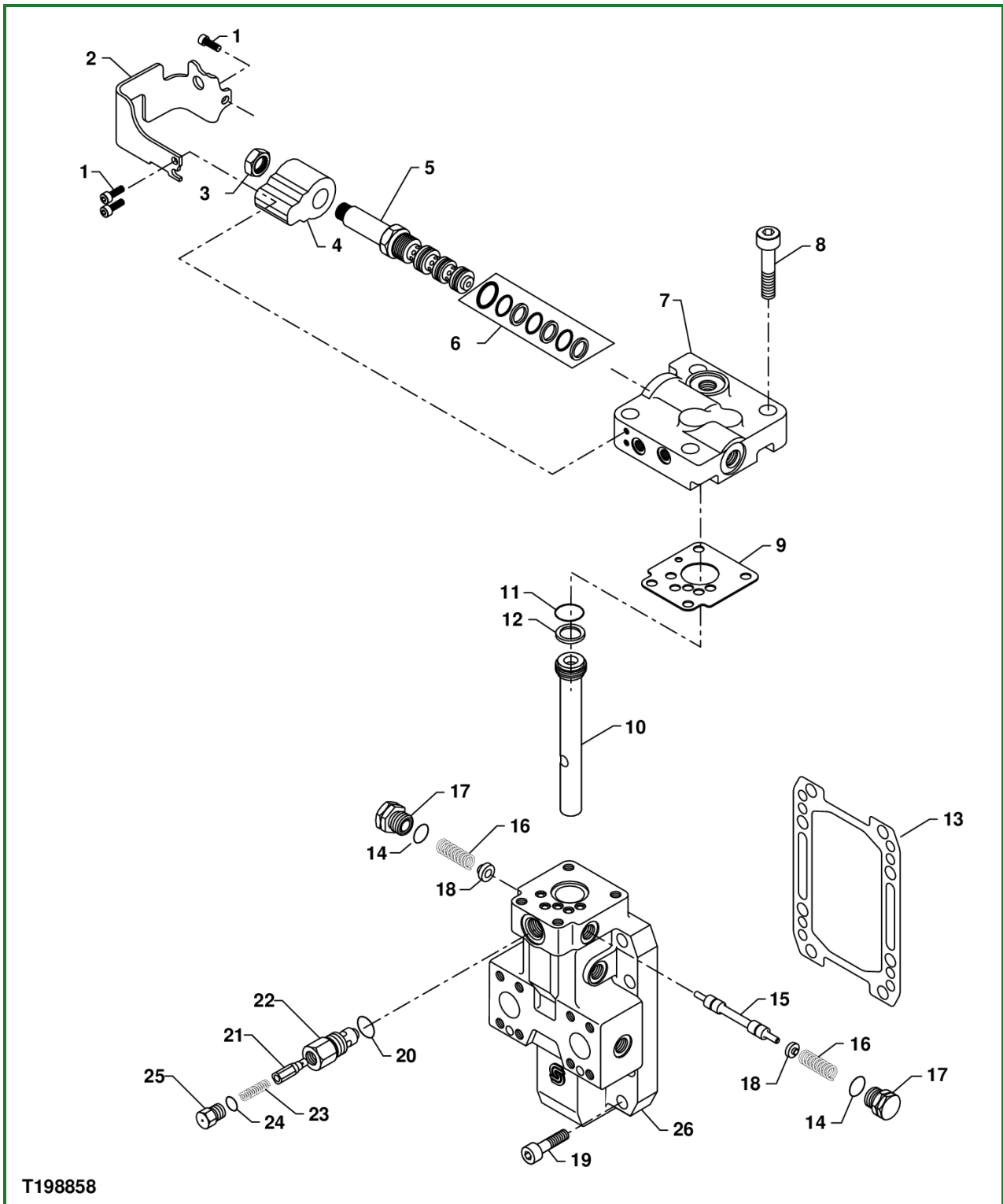

T198858-UN: Hydrostatic Motor Control Valve

LEGEND:

- 1 - Hex Socket Head Cap Screw (3 used)
- 2 - Bracket
- 3 - Nut
- 4 - Solenoid Valve Coil
- 5 - Solenoid Valve Spool
- 6 - Solenoid Valve O-Ring Kit
- 7 - Solenoid Valve Housing
- 8 - Hex Socket Head Cap Screw (4 used)

- 9 - Gasket
- 10 - Servo Piston
- 11 - O-Ring
- 12 - V-Ring
- 13 - Gasket
- 14 - O-Ring (2 used)
- 15 - Flushing Valve Spool
- 16 - Spring (2 used)
- 17 - Plug Fitting (2 used)
- 18 - Spring Plate (2 used)
- 19 - Hex Socket Head Cap Screw (8 used)
- 20 - O-Ring
- 21 - Poppet Valve
- 22 - Operating Charge Relief Valve Housing
- 23 - Spring
- 24 - O-Ring
- 25 - Plug Fitting
- 26 - End Cap Housing

NOTE:

Apply clean hydrostatic oil to all internal parts prior to assembly.

1. Clean and inspect parts.
2. Install new solenoid valve O-ring kit (6) on solenoid valve spool (5).
3. Install solenoid valve spool with O-rings in solenoid valve housing (7). Tighten to specification.

Item	Measurement	Specification
Solenoid Valve Spool	Torque	30 N·m 22 lb.-ft.

4. Install solenoid valve coil (4) in position as marked during removal.
5. Assemble nut (3) and tighten to specification.

Item	Measurement	Specification
Solenoid Valve Nut	Torque	6 N·m 53 lb.-in.

6. Assemble bracket (2) with hex socket head cap screws (1) and tighten to specification.

Item	Measurement	Specification
Bracket Hex Socket Head Cap Screw	Torque	15.3 N·m 11.3 lb.-in.

7. Install V-ring (12) and O-ring (11) onto servo piston (10). Install servo piston into end cap housing (26).
8. Install flushing valve spool (15) into end cap housing (26).

9. Install O-ring (14) onto plug fitting (17).
10. Install spring plate (18), spring (16), and plug fitting (17) into end cap housing (26). Tighten plug fitting to specification.

Item	Measurement	Specification
Flushing Valve Plug Fitting	Torque	37 N·m 27 lb.-ft.

Repeat installation of spring plate, spring, O-ring, and plug fitting on other side.

11. Install O-ring (24) onto plug fitting (25).
12. Install poppet valve (21), spring (23), and plug fitting (25) into operating charge relief valve housing (22). Tighten plug fitting to specification.

Item	Measurement	Specification
Operating Charge Relief Valve Plug Fitting	Torque	37 N·m 27 lb.-ft.

13. Install O-ring (20) onto operating charge relief valve housing (22). Install relief valve into end cap housing (26) and tighten to specification.

Item	Measurement	Specification
Operating Charge Relief Valve	Torque	52 N·m 38 lb.-ft.

14.

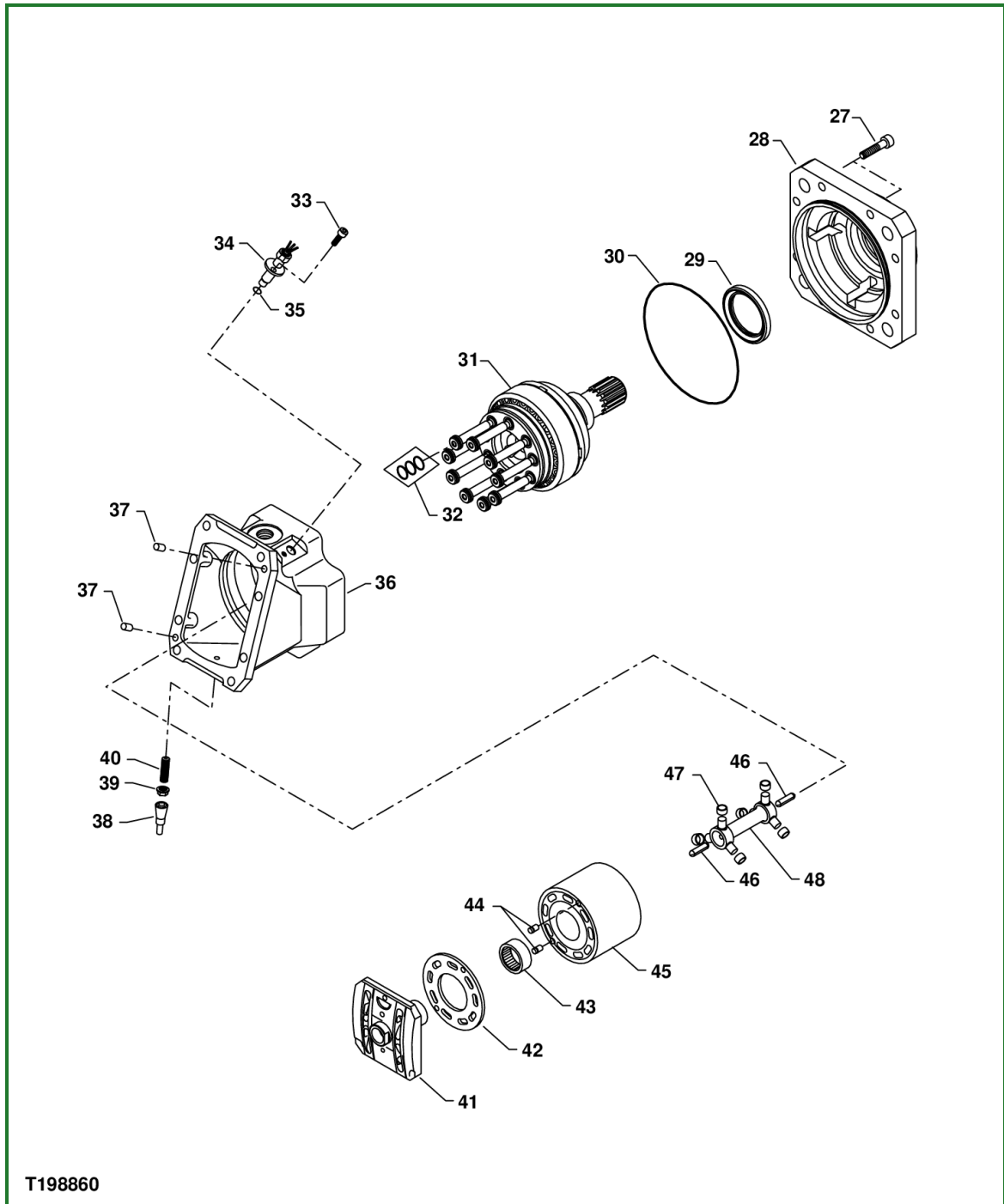

T198860-UN: Rotating Group Assembly

LEGEND:

- 27 - Hex Socket Head Cap Screw (8 used)
- 28 - Flange
- 29 - Seal
- 30 - O-Ring
- 31 - Shaft Assembly
- 32 - Seal Kit
- 33 - Hex Socket Head Cap Screw
- 34 - Speed Sensor
- 35 - O-Ring
- 36 - Rotating Group Housing
- 37 - End Cap Housing Alignment Pin (2 used)
- 38 - Cap
- 39 - Nut

- 40 - Set Screw
- 41 - Valve Segment
- 42 - Bearing Plate
- 43 - Cylinder Block Bearing
- 44 - Cylinder Block Alignment Pin (2 used)
- 45 - Cylinder Block
- 46 - Synchronizer Shaft Support Pin (2 used)
- 47 - Synchronizer Shaft Roller (6 used)
- 48 - Synchronizer Shaft

Install new seal kit (32) on pistons.

NOTE:

Shaft assembly (31) with exception of the seal kit (32) is serviced as an assembly.

15.

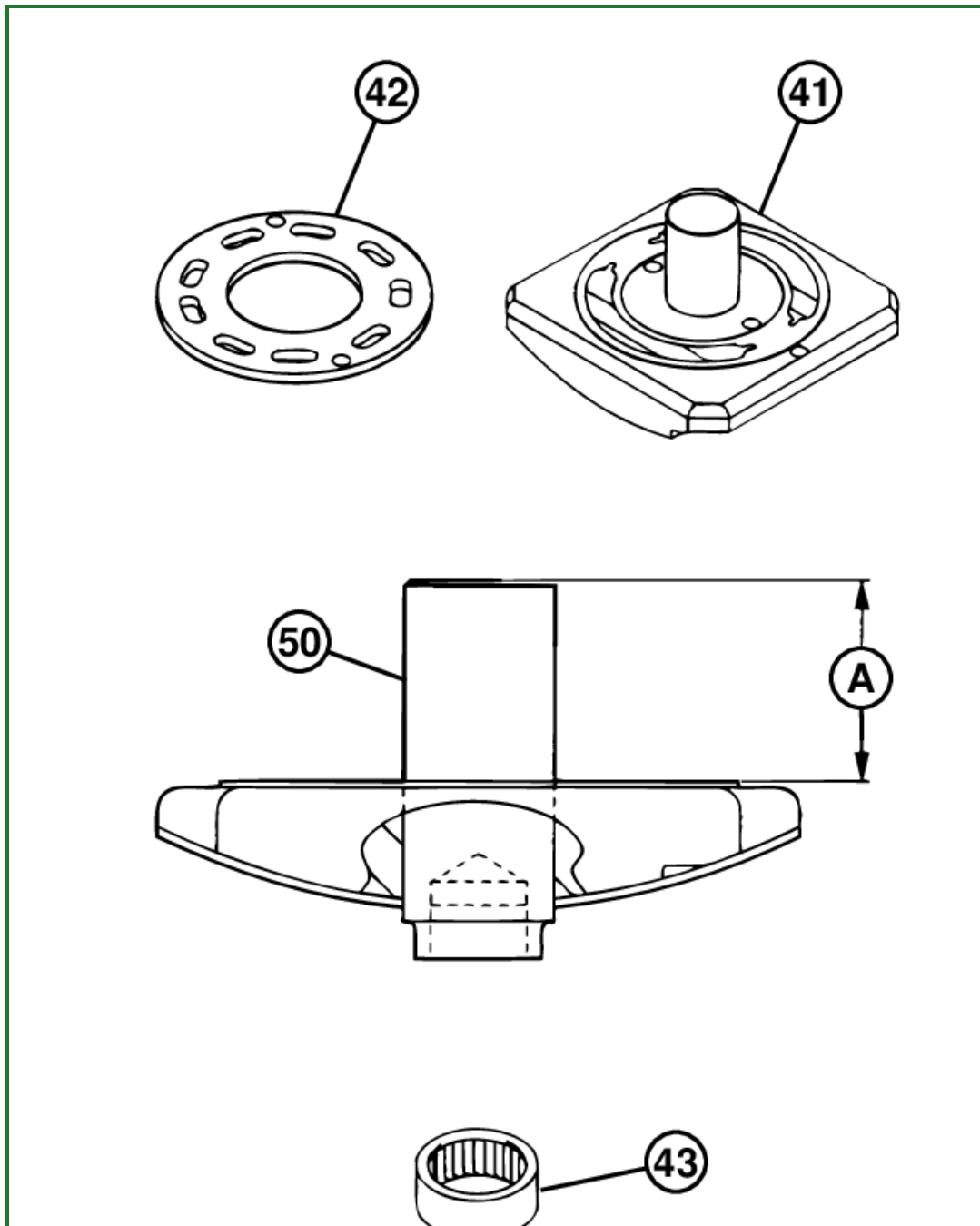

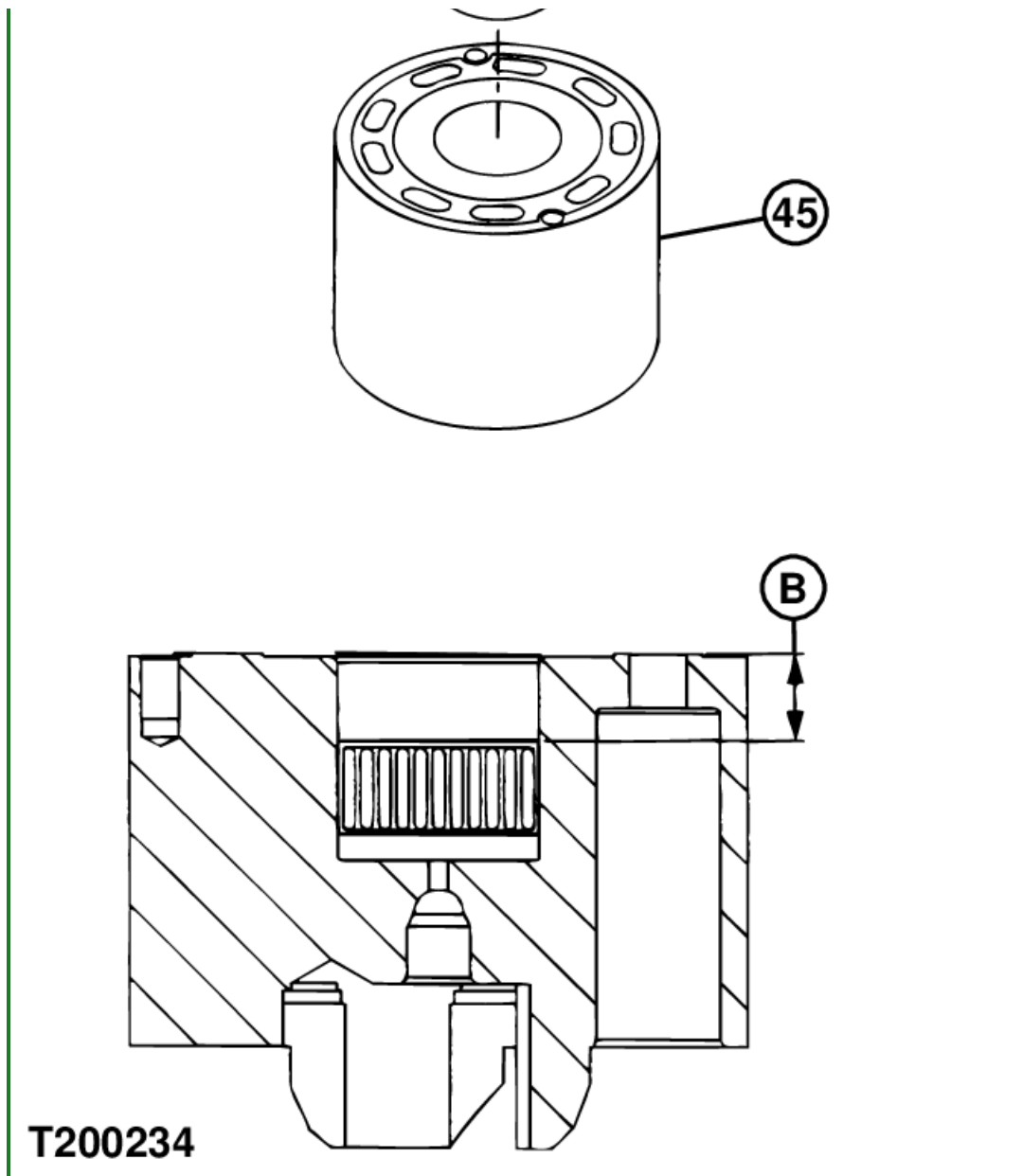
**T200234-UN: Valve Segment Spindle****LEGEND:**

- 41 - Valve Segment
- 42 - Bearing Plate
- 43 - Cylinder Block Bearing
- 45 - Cylinder Block
- 50 - Spindle
- A - Dimension "A"
- B - Dimension "B"

Inspect the bronze surface of the bearing plate (42) for damage and excessive wear. The sealing surfaces must be free from scratches and nicks. The cylinder block alignment pin (44) holes must not be worn. Replace the bearing plate if damaged or worn.

16. Inspect the valve segment (41) sealing surfaces and spindle (50) for damage or wear. Check that the spindle is located correctly in the valve segment by measuring dimension "A." If this dimension is not within the specification, the spindle has moved in the valve segment and the assembly must be replaced.

Item	Measurement	Specification
Valve Segment Spindle Dimension "A" Length		39.4—39.6 mm 1.55—1.56 in.

17. IMPORTANT:

DO NOT damage sealing surface of cylinder block.

Inspect cylinder block (45) for wear or damage. The piston bores must be smooth. The bearing plate surface must be free from scratches or nicks, and the holes for the end cap housing alignment pins (37) must not be worn. The races for the synchronizer shaft rollers must not be worn.

18. Inspect cylinder block bearing (43). If it requires replacement, remove bearing using a suitable puller. DO NOT damage the bearing plate surface of the cylinder block.

Press a new bearing (if removed) into the cylinder block until it is located at the proper distance (dimension "B") below the bearing plate.

Item	Measurement	Specification
Cylinder Block Bearing Dimension "B" Depth		14.5—15.0 mm 0.57—0.59 in.

19. Place shaft assembly on a clean soft surface (cardboard or shop towel) to replace speed ring. Be careful NOT to damage sealing surface of shaft assembly.

20. Place new speed ring on piston side of shaft assembly.

21. IMPORTANT:

To prevent damage to speed ring use installation tool JDG1332 Speed Ring Installer.

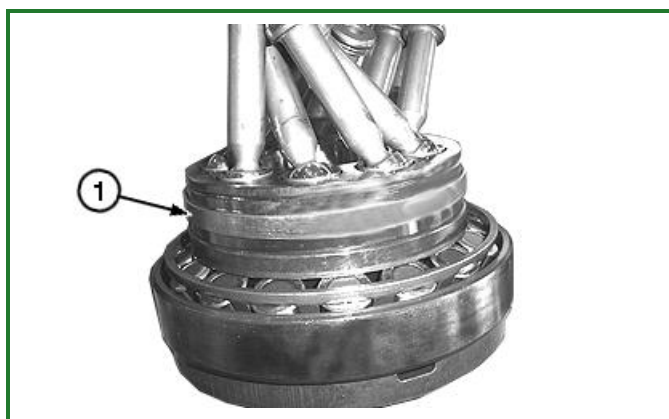

TX1012509A-UN: Speed Ring Shown Installed

LEGEND:

1 - Speed Ring

Carefully place JDG1332 Speed Ring Installer over shaft assembly pistons. Alternately tap edge of installer using a rubber mallet to seat speed ring. Speed ring will be located correctly when installer is bottomed on shaft assembly.

22.

NOTE:

Apply clean hydrostatic oil to all internal parts prior to assembly.

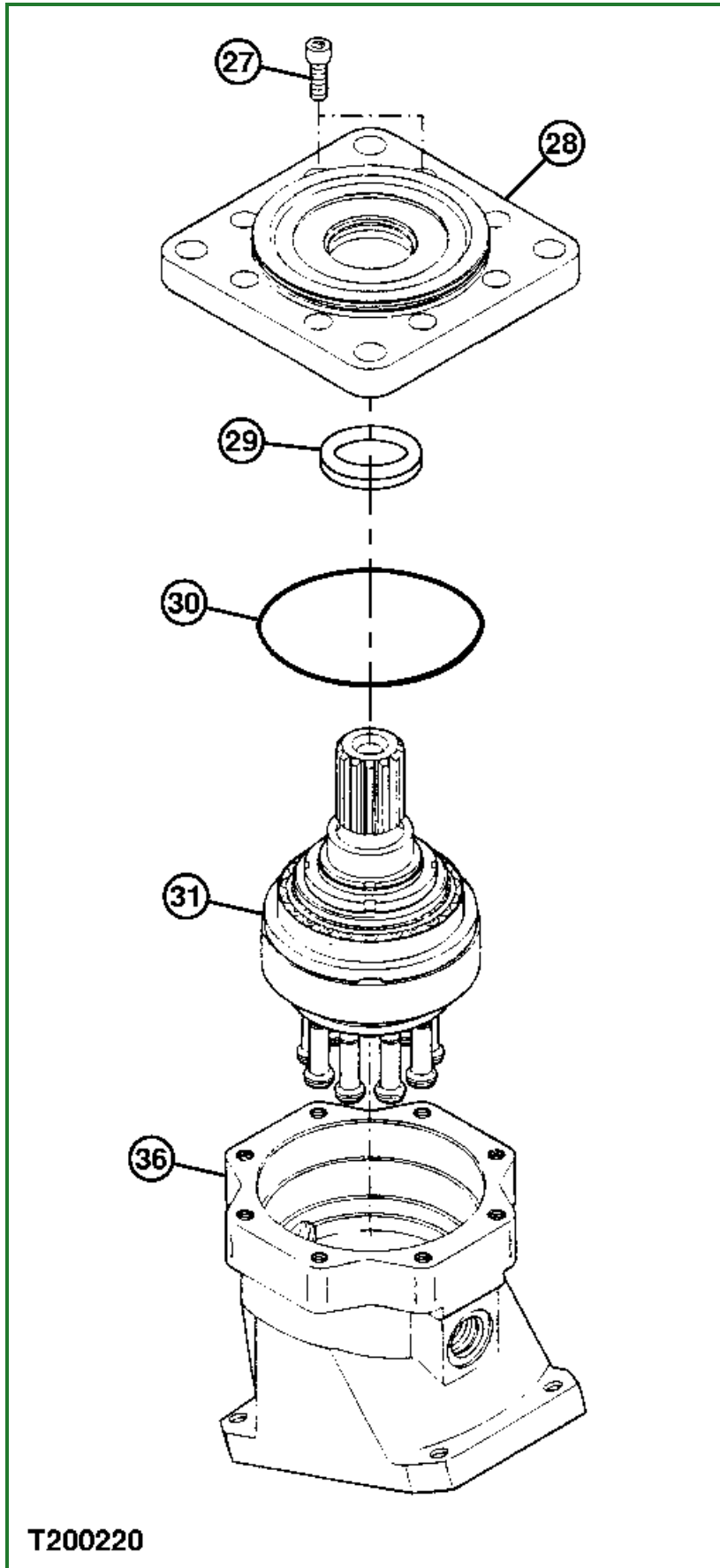

T200220

T200220-UN: Shaft Assembly

LEGEND:

29 - Seal

27 - Hex Socket Head Cap Screw (8 used)

28 - Flange

30 - O-Ring

31 - Shaft Assembly

36 - Rotating Group Housing

Position motor shaft assembly (31) in rotating group housing (36). Align scribe mark between housing and flange (28). Install flange over motor shaft assembly as far as possible.

Install two screws (M12 x 65 mm) 180° apart on flange. Alternately tighten screws until bottomed to seat flange and motor shaft assembly. Remove two 65 mm (2.56 in.) screws and repeat procedure using 50 mm (1.97 in.) screws. Remove screws.

Install eight hex socket head cap screws (27). Alternately tighten screws to seat motor shaft assembly and flange against housing. Torque screws to specification.

Item	Measurement	Specification
Flange-to-Motor Housing Cap Screw—	Torque	110 N·m 81 lb.-ft.

23.

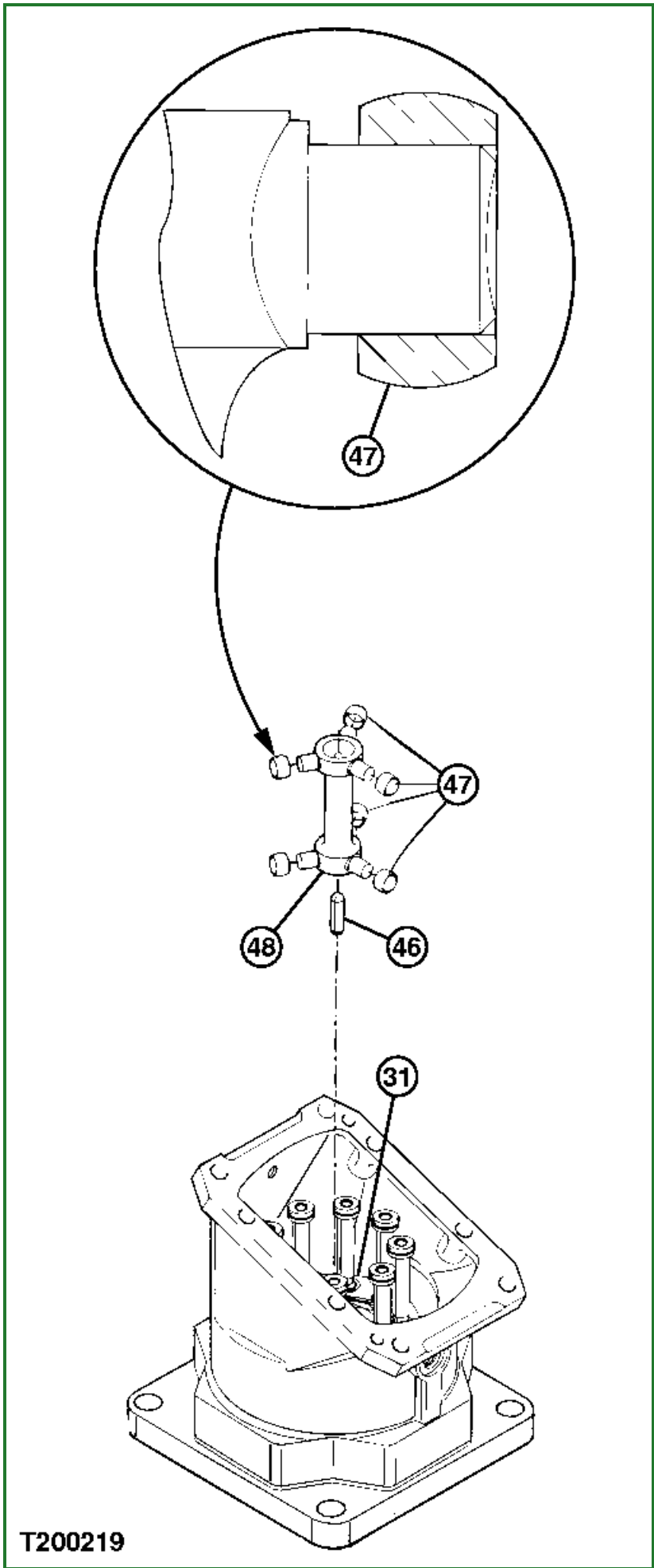

T200219

T200219-UN: Synchronizer Shaft

LEGEND:

- 31 - Shaft Assembly
- 46 - Synchronizer Shaft Support Pin (2 used)
- 47 - Synchronizer Shaft Roller (6 used)
- 48 - Synchronizer Shaft

Install synchronizer shaft support pin (46) into the shaft assembly (31) and retain with petroleum jelly.

24. Install the synchronizer shaft rollers (47) on the journals of the synchronizer shaft (48) and retain with petroleum jelly. Position each synchronizer shaft roller with its outside edge even with the end of the synchronizer shaft journal.

25. IMPORTANT:

Install synchronizer shaft correctly. The cylinder block end of the shaft is larger than the motor shaft end. Internal machine damage can occur.

Install the synchronizer shaft and synchronizer shaft rollers into the motor shaft assembly.

26. The synchronizer shaft rollers must enter the races in the motor shaft insert, and the recess in the end of the synchronizer shaft must engage the synchronizer shaft support pin.

Tip and rotate the synchronizer shaft in all directions to check for binding. The synchronizer shaft rollers must move freely in the races in the motor shaft insert.

27.

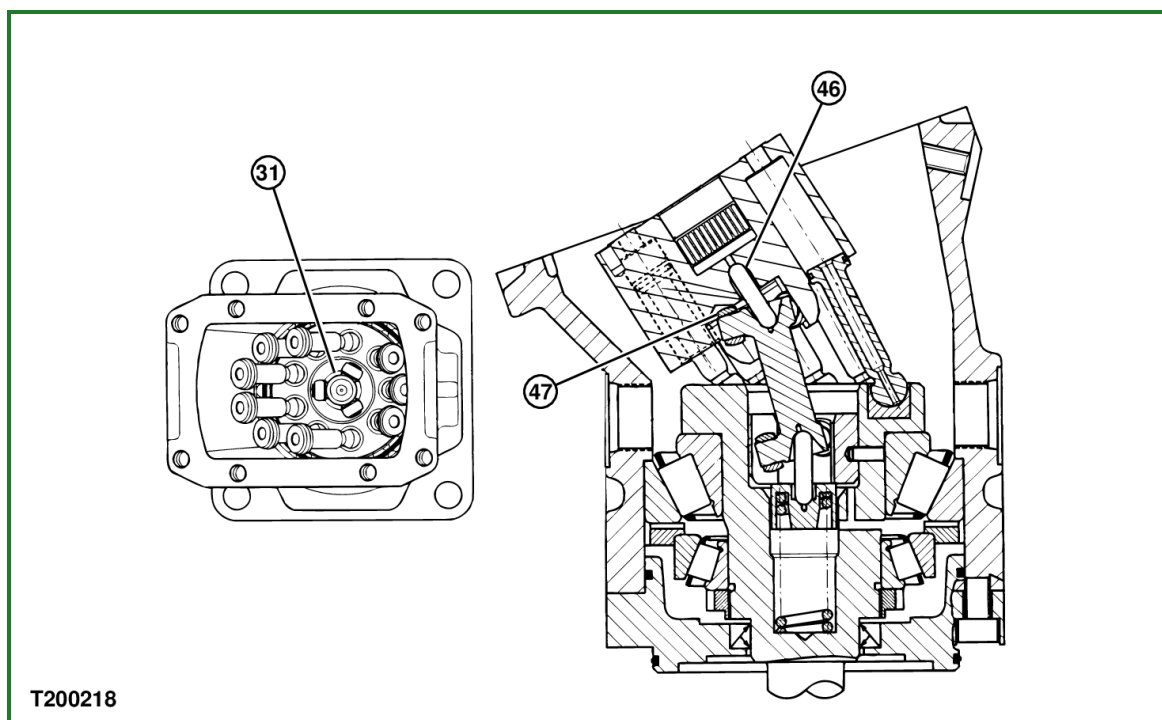

T200218-UN: Cylinder Block

LEGEND:

- 31 - Synchronizing Shaft
- 46 - Synchronizer Shaft Support Pin (2 used)
- 47 - Synchronizer Shaft Roller (6 used)

Position the synchronizing shaft in the housing as shown. Tip the three pistons closest to the highest side of housing.

28.

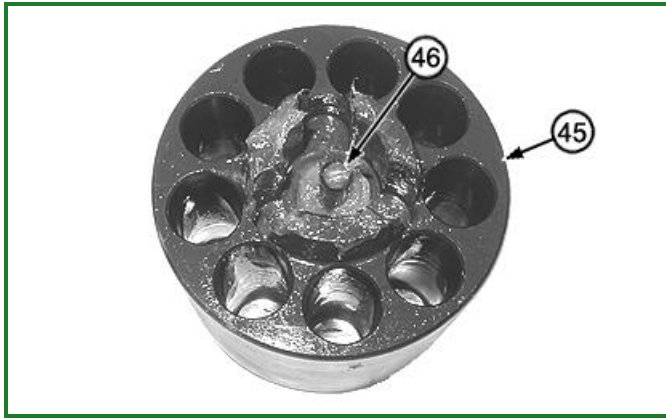
**T200221A-UN: Support Pin****LEGEND:**

45 - Cylinder Block

46 - Synchronizer Shaft Support Pin (2 used)

Install the second synchronizer shaft support pin (46) into the recess of the cylinder block and retain with petroleum jelly.

29. **IMPORTANT:**

Install cylinder block correctly. The cylinder block must be positioned so the synchronizer shaft rollers will enter their races in the block, while each piston enters its corresponding bore in the block. Internal machine damage can occur.

With the synchronizing shaft supported in the shaft assembly, install the cylinder block (45) and its synchronizer shaft support pin (46) onto the pistons and synchronizer shaft.

30.

NOTE:

A brass rod may be inserted through the cylinder block to guide the pistons into position.

**T200222A-UN: Cylinder Block Assembly**

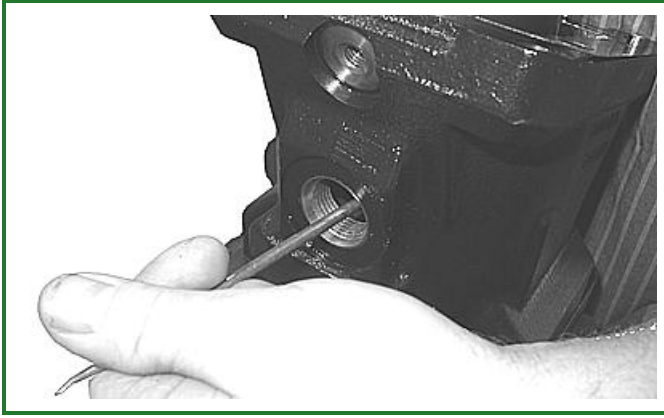
**T200223A-UN: Cylinder Block Assembly**

Start with the six pistons closest to the lower part of the end cap mounting surface. After the six pistons enter their bores, tilt the cylinder block so the synchronizer shaft rollers (47) enter their races in the cylinder block, and the support pin enters its recess in the synchronizer shaft.

31.

NOTE:

Apply clean hydrostatic oil to all cylinder block bores.

Lift the cylinder block slightly and guide the three remaining pistons into their bores.

After the last piston is in position, check the position of the rollers at highest side of housing. Maintain an inward force on the cylinder block and carefully push it toward the highest part of the housing to check that all synchronizer shaft rollers are in position.

If cylinder block is properly assembled, there will be very little (if any) rotational free play between the block and the motor shaft.

32.

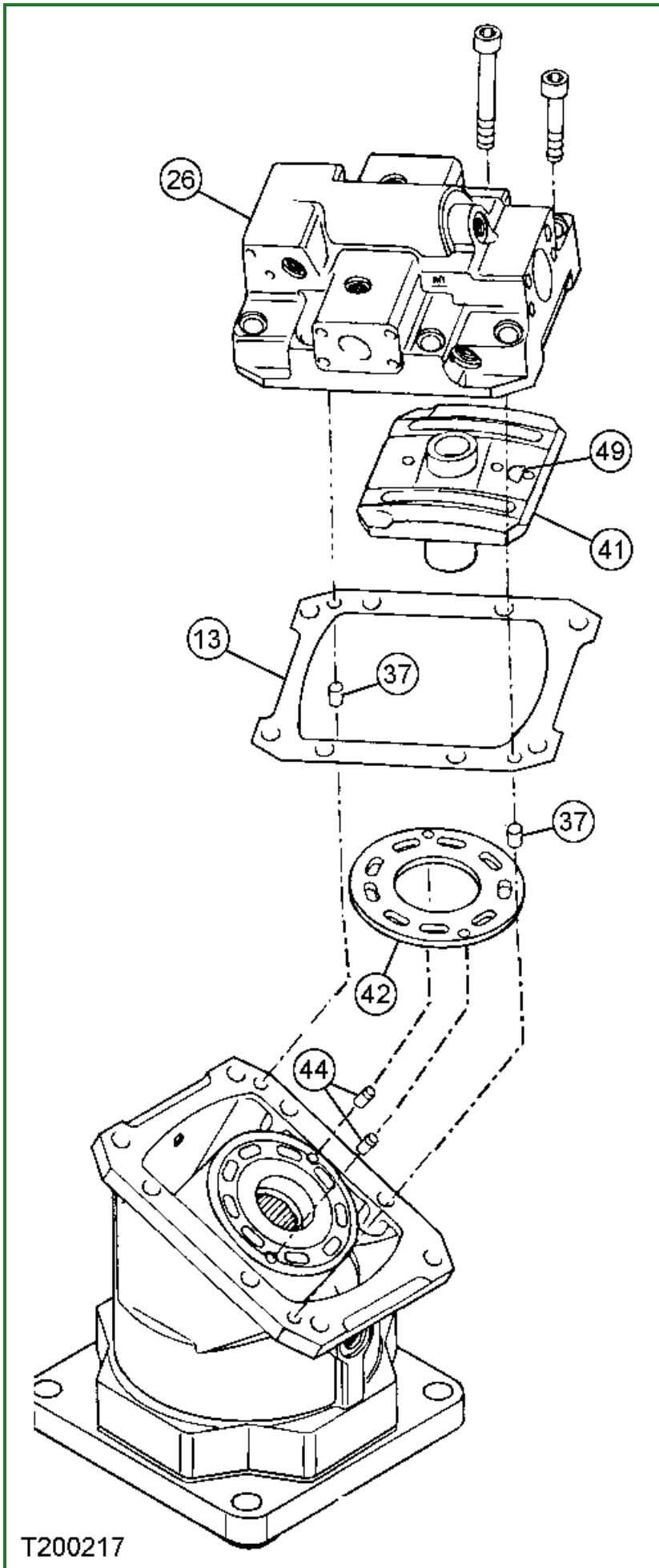

T200217

T200217-UN: Bearing Plate

LEGEND:

- 13 - Gasket
- 26 - End Cap Housing
- 37 - End Cap Housing Alignment Pin (2 used)
- 41 - Valve Segment
- 42 - Bearing Plate
- 44 - Cylinder Block Alignment Pin (2 used)
- 49 - Hole

Install the cylinder block alignment pins (44) into cylinder block. The longer end of each shouldered pin is installed into block.

33. Install the bearing plate (42) on the cylinder block with the steel side facing toward the block. Lubricate the bronze side of the plate with clean hydrostatic oil.
34. Install end cap housing alignment pin (37) and gasket (13). Carefully locate the cylinder block against highest part of housing.
35. **IMPORTANT:**

DO NOT allow the pistons or synchronizer shaft rollers to fall out of position. Internal machine damage can occur.

Apply petroleum jelly to mating surfaces of valve segment and end cap. Install the valve segment (41), with hole (49) on opposite side of speed sensor, into the end cap housing (26) so the spindle engages the setting lug in the servo piston. Locate the valve segment and servo piston in the approximate center of its travel.

36.

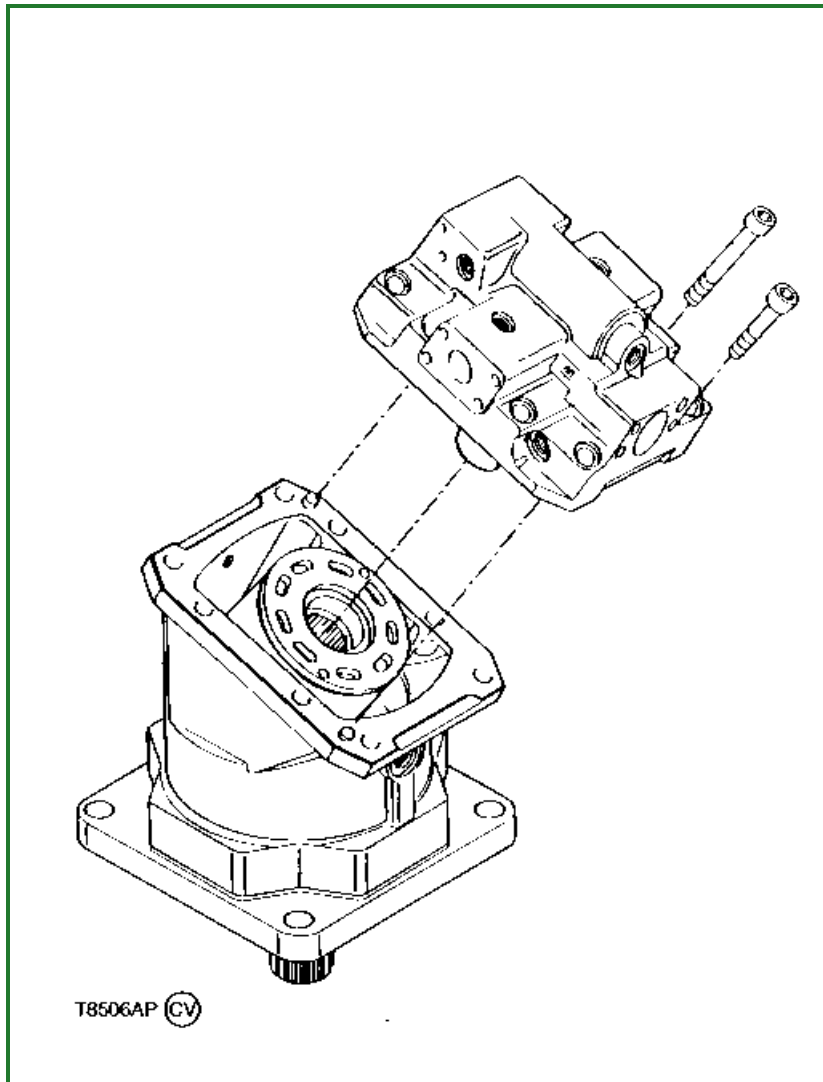

T8506AP-UN: End Cap Assembly & Valve Segment

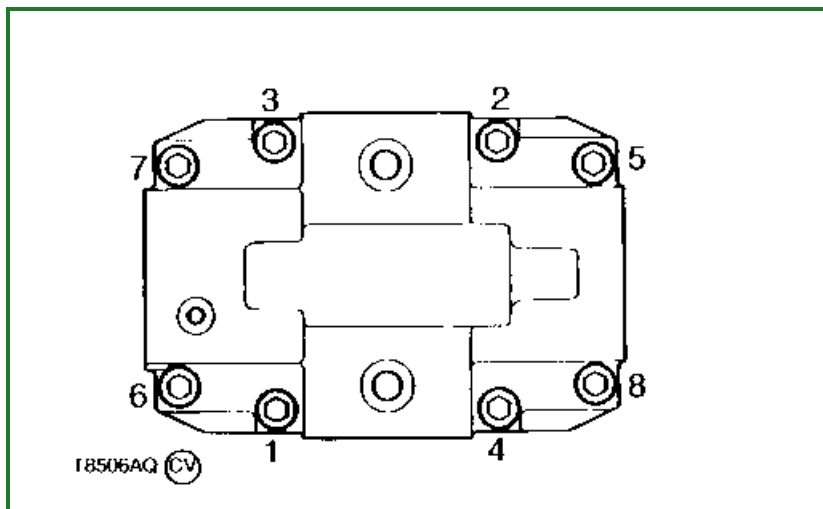

T8506AQ-UN: Screw Torque

Apply clean hydrostatic oil to valve segment and bearing plate mating surfaces. Install end cap assembly and valve segment. The spindle must engage the bearing in the cylinder block.

37. **IMPORTANT:**

DO NOT allow the pistons or synchronizer shaft rollers to fall out of position. Internal machine damage can occur.

Install hex socket head cap screws (19).

38.

NOTE:

The internal spring in the motor shaft should hold the end cap away from the housing a short distance.

Tighten the screws by hand in the sequence shown (1—8) while rotating the motor shaft to ensure proper positioning of the synchronizer shaft rollers.

39. **IMPORTANT:**

DO NOT force the end cap into position on the housing. Internal machine damage can occur.

Tighten screws using sequence shown to approximately 1/2 final torque value. Repeat sequence and tighten to final torque.

Item	Measurement	Specification
Motor End Cap-to-Housing Cap Screw—	Torque	74 N·m 55 lb.-ft.

40. Rotate shaft 360° to check final assembly.

41. Install gasket (9) and solenoid valve assembly onto end cap housing with hex socket head cap screws (8).

42. Tighten screws to specification.

Item	Measurement	Specification
Solenoid Valve-to-End Cap Screw—	Torque	110 N·m 81 lb.-ft.

Go to [Section_03:Group_0360](#)

TE14778,0000020-19-20090721

Oil Cooler Thermal Bypass Valve Remove and Install

1.

NOTE:

The approximate capacity of the hydrostatic reservoir is 43 L (11.3 gal).

NOTE:

Hoses removed for clarity.

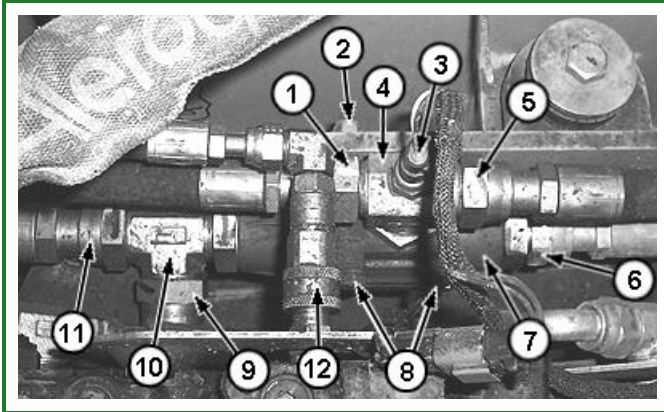
**T199914A-UN: Oil Cooler Bypass Valve****LEGEND:**

- 1 - Left Hydrostatic Motor Tee Fitting-to-Oil Cooler Thermal Bypass Valve
- 2 - Nut (2 used)
- 3 - Temperature Sensor Wire
- 4 - Tee Fitting
- 5 - Oil Cooler Thermal Bypass Valve-to-Front Hydrostatic Pump Tee Fitting
- 6 - Oil Cooler Thermal Bypass Valve-to-Oil Cooler Inlet
- 7 - Oil Cooler Thermal Bypass Valve
- 8 - Cap Screws (2 used)
- 9 - Oil Cooler Outlet-to-Oil Cooler Thermal Bypass Valve
- 10 - Tee Fitting
- 11 - Oil Cooler Thermal Bypass Valve-to-Reservoir
- 12 - Park Brake Quick Coupler

Drain or apply a vacuum to hydrostatic reservoir.

2. Disconnect temperature sensor wire (3).
3. Disconnect hoses (1, 5, 6, 9, and 11).
4. Remove cap screws (8) and nuts (2).
5. Remove oil cooler thermal bypass valve (7). Replace parts as needed.
6. Install oil cooler thermal bypass valve (7) using cap screws (8) and nuts (2). Tighten cap screws to specification.

Item	Measurement	Specification
Oil Cooler Thermal Bypass Valve Mounting Cap Screws	Torque	80 N·m 60 lb-ft

7. Install hoses (1, 5, 6, 9, and 11).
8. Install temperature sensor wire (3).
9. Fill reservoir if drained. [See Transmission and Hydraulic Oil](#) . (Operators Manual.)

Item	Measurement	Specification
Hydrostatic Reservoir	Capacity	43 L Approximate 11.3 gal Approximate

Go to [Section_03:Group_0360](#)

TE14778,000003C-19-20120501

Hydrostatic Filter Remove and Install

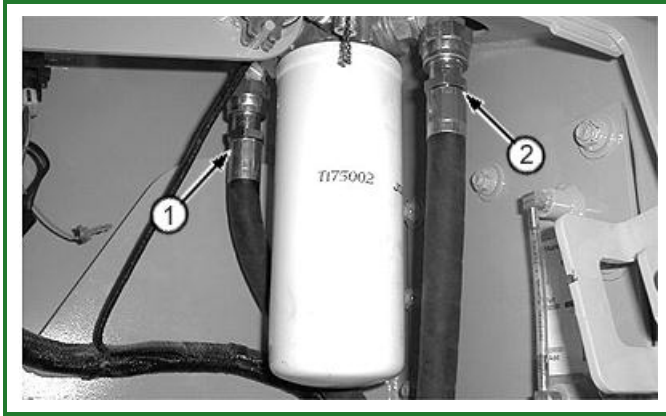

T118008B-UN: Hydrostatic Filter

LEGEND:

- 1 - Hydrostatic Filter-to-Hydrostatic Pump Hose
- 2 - Hydrostatic Pump-to-Hydrostatic Filter Hose

1. Loosen filler plug on reservoir to release pressure.
2. Tag and disconnect hoses (1 and 2). Cap or plug all openings.
3. Disconnect hydrostatic filter wiring lead.
4. Loosen cap screws on top of filter base and slide cap screws through slots to remove filter.
5. Install filter and tighten cap screws.

Item	Measurement	Specification
Hydrostatic Filter		
Hydrostatic Reservoir-to-Filter Base Cap Screws	Torque	50 N·m 37 lb-ft

6. Connect hoses to filter and wiring lead.

Go to [Section_03:Group_0360](#)

CED,OUTX547,121-19-20040514

Hydrostatic Filter Disassemble and Assemble

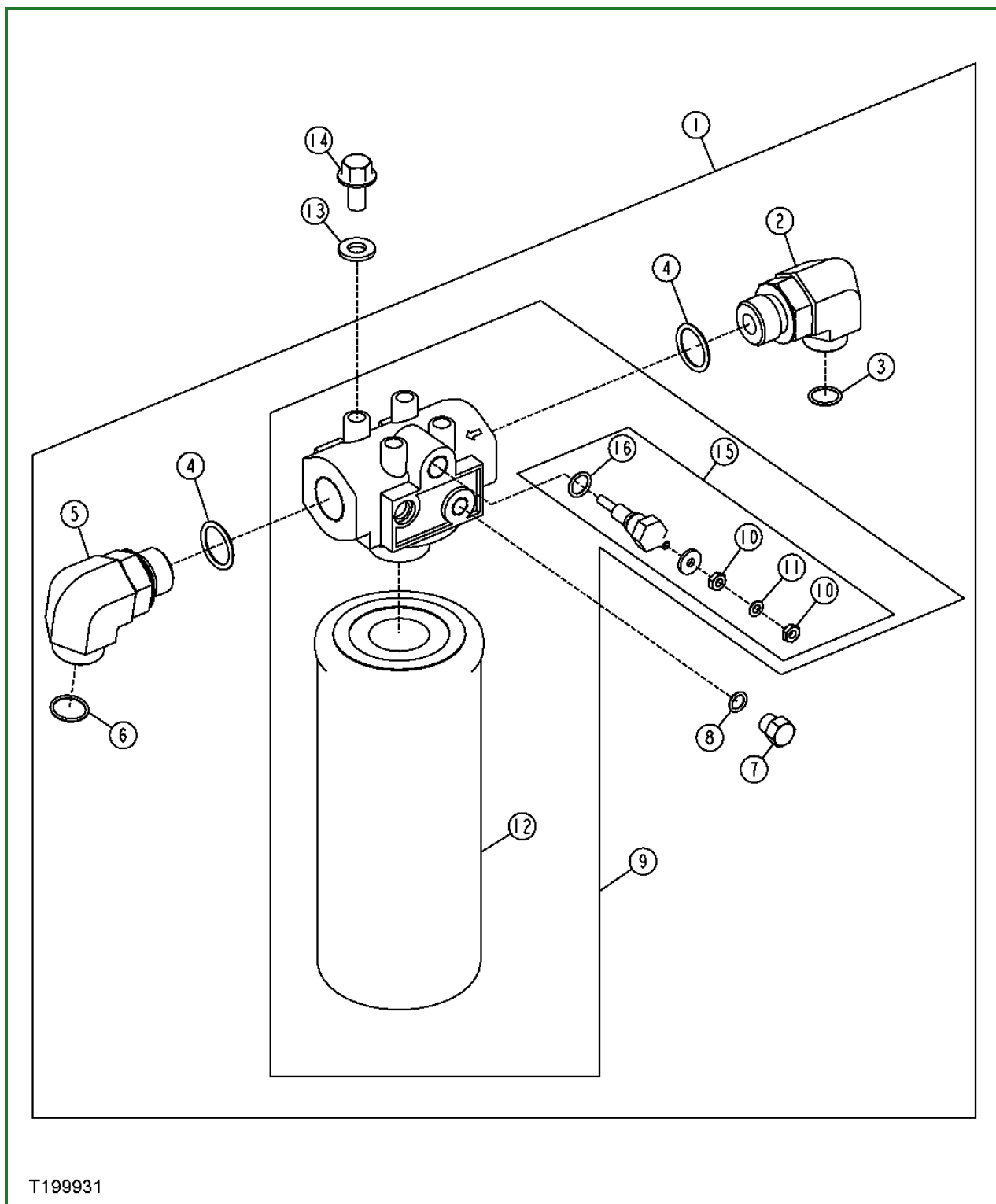

T199931

T199931-UN: Hydrostatic Filter**LEGEND:**

- 1 - Hydrostatic Filter Assembly
- 2 - Elbow Fitting
- 3 - O-Ring
- 4 - O-Ring (2 used)
- 5 - Elbow Fitting
- 6 - O-Ring
- 7 - Plug Fitting
- 8 - O-Ring

- 9 - Filter Base and Filter
- 10 - Nut (2 used)
- 11 - Washer
- 12 - Filter
- 13 - Washer (4 used)
- 14 - Cap Screw (4 used)
- 15 - Restriction Indicator Switch
- 16 - O-Ring

1. Disassemble parts as shown.
2. Inspect parts. Replace if necessary.
3. Tighten plug (7) to specification.

Item	Measurement	Specification
Hydrostatic Filter Plug	Torque	11 N·m 97 lb-in.

4. Tighten restriction indicator switch (15) to specification.

Item	Measurement	Specification
Hydrostatic Filter Restriction Indicator Switch	Torque	1.4—6.8 N·m 12—60 lb-in.

Go to [Section_03:Group_0360](#)

TE14778,000003D-19-20040514

Hydrostatic Reservoir Remove and Install

1. Turn battery disconnect switch to OFF.
2. Remove cab or ROPS. See [Cab or ROPS Remove and Install](#) . (Group 1800.)

3. **NOTE:**

The approximate capacity of the hydrostatic reservoir is 43 L (11.3 gal).

Drain reservoir.

- 4.

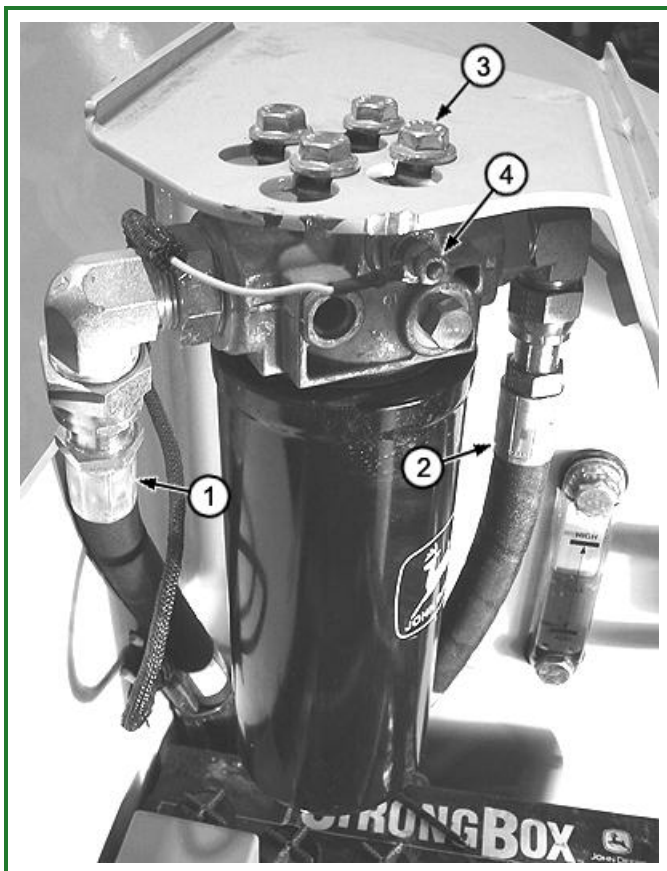

T200315A-UN: Hydrostatic Reservoir and Filter

LEGEND:

- 1 - Hose (Hydrostatic Filter Outlet-to-Rear Charge Pressure Manifold Inlet Tee Fitting)
- 2 - Hose (Hydrostatic Filter Inlet-to-Rear Charge Pressure Manifold Outlet Tee Fitting)
- 3 - Hydrostatic Reservoir-to-Oil Filter Flanged Head Cap Screw (4 used)
- 4 - Oil Filter Restriction Switch

Disconnect hoses (1 and 2) from hydrostatic filter. Cap or plug all openings.

5. Disconnect wire to hydrostatic oil filter restriction switch (4).
6. Loosen flanged head cap screws (3) on filter and slide through slot to remove filter.
7. Disconnect battery cables and remove batteries.

8.

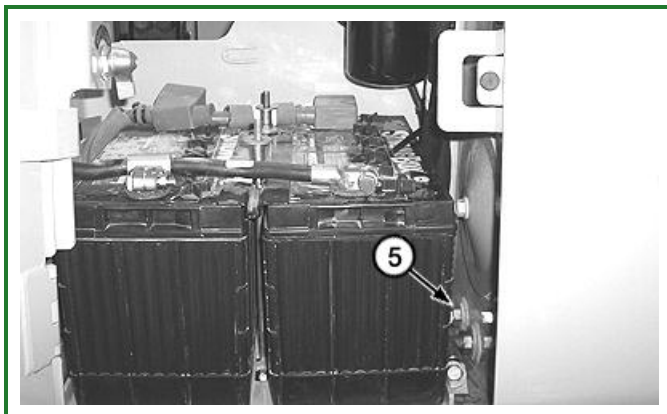

T200324A-UN: Hydrostatic Reservoir



T200325A-UN: Hydrostatic Reservoir Plumbing

LEGEND:

- 5 - Hose (Park Brake Outlet-to-Hydrostatic Reservoir)
- 6 - Hose (Oil Cooler Bypass Valve-to-Hydrostatic Reservoir)
- 7 - Hose (Hydrostatic Reservoir-to-Charge Pump)

Disconnect hoses (5—7). Cap or plug all openings.

9. Remove necessary tie bands and route oil filter restriction switch harness and hoses through reservoir frame.

10. **⚠ CAUTION:**

The approximate weight of hydrostatic reservoir is 96 kg (212 lb).

Item	Measurement	Specification
Hydrostatic Reservoir		
Reservoir Weight		96 kg Approximate 212 lb Approximate

Install chain and hoist.

11.

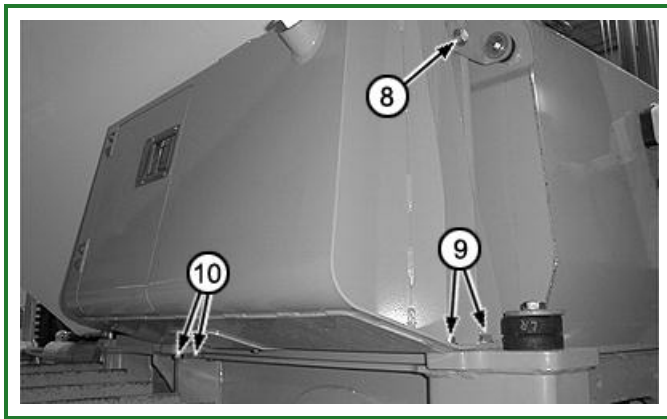

T200334A-UN: Hydrostatic Reservoir

LEGEND:

- 8 - Bracket-to-Hydrostatic Reservoir Cap Screw
- 9 - Hydrostatic Reservoir-to-Main Frame Rear Cap Screw (2 used)
- 10 - Hydrostatic Reservoir-to-Main Frame Front Cap Screw (2 used)

Loosen rear bracket to fuel tank cap screw and remove cap screws (8—10).

12. Remove reservoir.

13. Install reservoir using cap screws (8—10). Tighten cap screws to specification.

Item	Measurement	Specification
Hydrostatic Reservoir		
Main Frame-to-Reservoir Front Cap Screws	Torque	319 N·m 235 lb-ft
Main Frame-to-Reservoir Rear Cap Screws	Torque	310 N·m 235 lb-ft
Fuel Tank Bracket-to-Hydrostatic Reservoir	Torque	244 N·m 180 lb-ft
Brackets-to-Isolators-to-Fuel Tank Cap Screws	Torque	87 N·m 64 lb-ft

14. Route filter hoses and oil filter restriction switch harness through reservoir frame. Connect harness to oil filter restriction switch. Tighten hex nut to specification.

Item	Measurement	Specification
	Torque	0.56—0.79 N·m 5—7 lb-in.

15. Install filter and tighten cap screws.

Item	Measurement	Specification
Hydrostatic Filter		
Hydrostatic Reservoir-to-Filter Base Cap Screws	Torque	50 N·m 37 lb-ft

16. Connect hydrostatic filter hoses.

17. Replace all tie bands that were removed.

18. Install batteries and connect cables.

19. Install cab/ROPS. See [Cab or ROPS Remove and Install](#) . (Group 1800.)
20. Fill reservoir. See [Transmission and Hydraulic Oil](#) . (Operators Manual.)

Item	Measurement	Specification
Hydrostatic Reservoir	Capacity	43 L Approximate 11.3 gal Approximate

21. Turn battery disconnect switch to ON.

Go to [Section_03:Group_0360](#)

TE14778,0000042-19-20040526

Section 04: Engine

Group 0400: Removal and Installation

Engine Remove and Install

Engine Remove and Install

1.

⚠ CAUTION:

Explosive release of fluids from pressurized cooling system can cause serious burns.

Shut off engine. Only remove filler cap when cool enough to touch with bare hands. Slowly loosen cap to first stop to relieve pressure before removing completely.

**TS281-UN: Explosive Fluids**

Drain engine coolant. See [Miscellaneous—Specifications](#) . (Operator's Manual)

2. Remove engine side shields.
3. Remove hood. See [Hood Remove and Install](#) . (Group 1910.)
4. Turn battery disconnect switch to OFF.
5. Remove fan blade and shroud. See [Fan Blade and Shroud Remove and Install \(450J, 550J\)](#) or [Remove and Install Fan blade and Shroud \(650J\)](#) . (Group 0510.)

6.

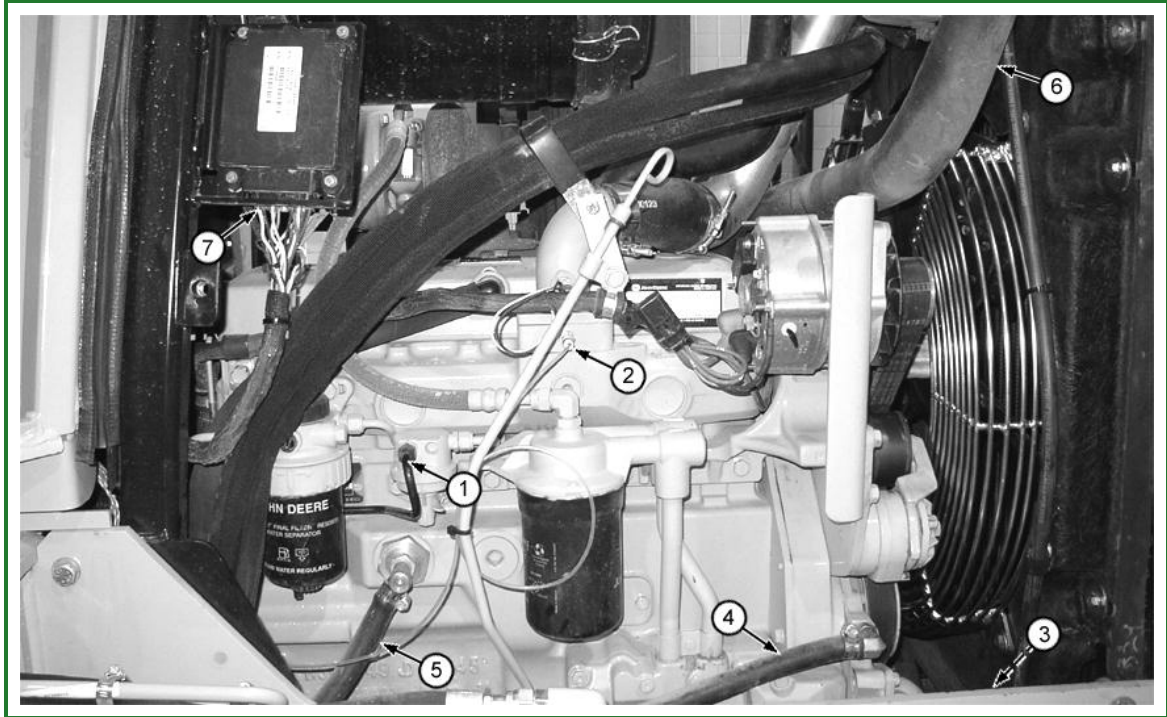

T193925A-UN: Engine (Right Side)

LEGEND:

- 1 - Fuel Supply Line
- 2 - Start Aid Line
- 3 - Lower Radiator Hose
- 4 - Return Heater Hose
- 5 - Supply Heater Hose
- 6 - Upper Radiator Hose
- 7 - Engine Control Unit (ECU) Connector

Disconnect components (1—7).

7.

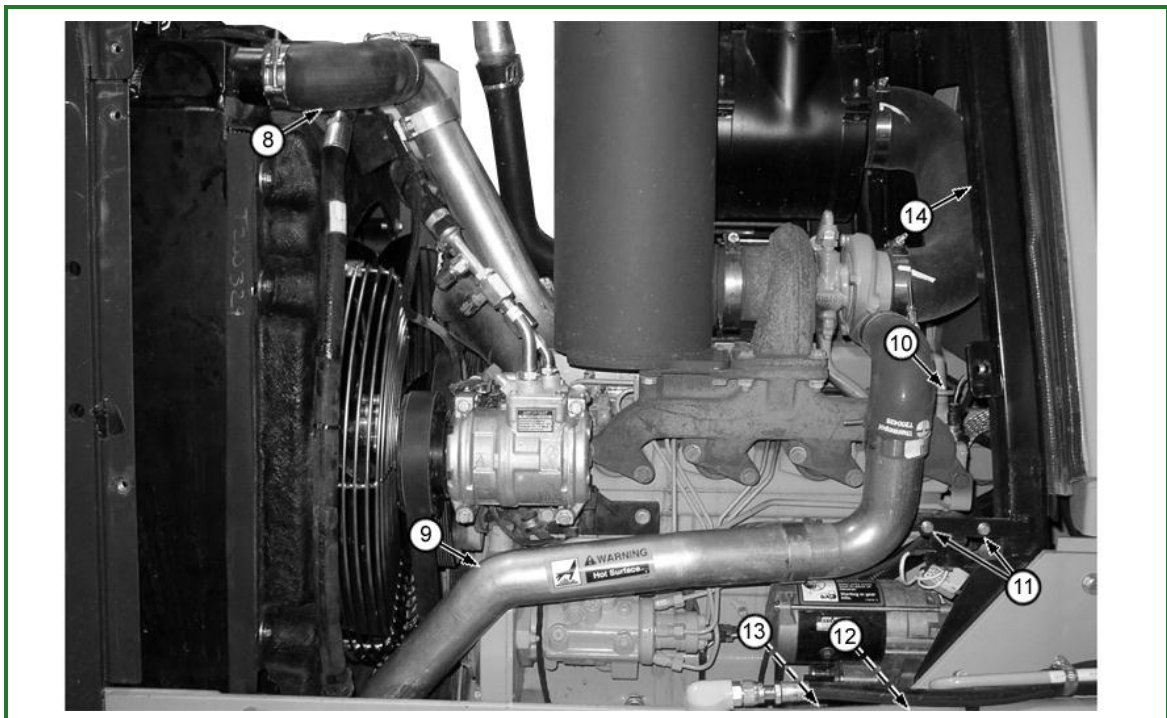

T193926A-UN: Engine (Left Side)

LEGEND:

- 8 - Upper Charge Air Cooler Hose
- 9 - Lower Charge Air Cooler Hose
- 10 - Fuel Return Line
- 11 - Start Relay Cap Screw (2 used)
- 12 - Ground Strap and Starter Ground Cable
- 13 - Start Solenoid Positive Cable
- 14 - Rear Hood Bracket with Air Cleaner

Disconnect components (8—14).

- 8. Remove muffler. See [Muffler Without Turbocharger Remove and Install](#) or [Muffler With Turbocharger Remove and Install](#) . (Group 0530.)
- 9. Remove rear support with air cleaner housing, hose, and Engine Control Unit (ECU).
- 10. If equipped, remove air conditioning compressor and set aside.

11.

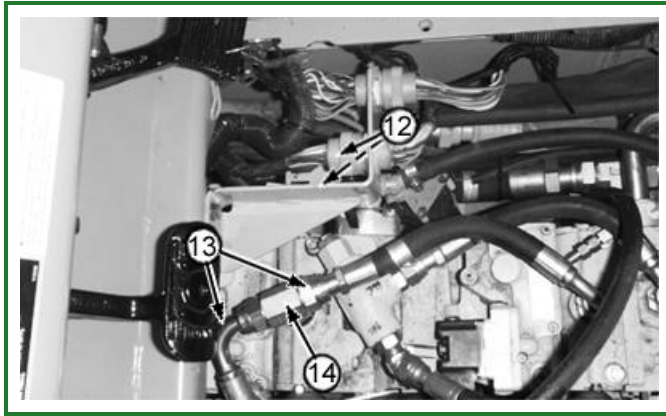

T117450B-UN: Engine Harness Connector and Lines

LEGEND:

- 12 - Engine Harness Connector and Red Bulkhead Connector
- 13 - Cooler Bypass Hose (2 used)
- 14 - Tee Fitting

Remove floor plate and disconnect cooler bypass hoses (13) from tee at pump case drain port.

- 12. Disconnect engine harness connector and red bulkhead connector (12).
- 13. Remove cap screws (12 used) from pump flywheel cover to engine.
- 14. Disconnect tee fitting (14) at pump case drain port.

15.



T117452B-UN: Pump Eyebolt



T117451B-UN: DFT1119 Pump Support

Drill and tap a 1-1/16 in. plug to accommodate a 1/2 in. shouldered lift eyebolt. Install plug and eyebolt in pump case drain port. Trim end of eyebolt so it is even with end of plug.

16. Support hydrostatic pumps using JT07184 Pump Support Bracket or a **DFT1119** [Pump Support Dealer Fabricated Tool. See Group 0999 for instructions to make tool.] and a small winch hoist.

17.

⚠ CAUTION:

Prevent possible crushing injury from removing engine. Use proper lifting equipment and safety precautions.

Item	Measurement	Specification
Engine Weight		500 kg 1102 lb



T117453B-UN: JDG23 Lifting Sling

Attach JDG23 Lifting Sling and a hoist to engine.

18.

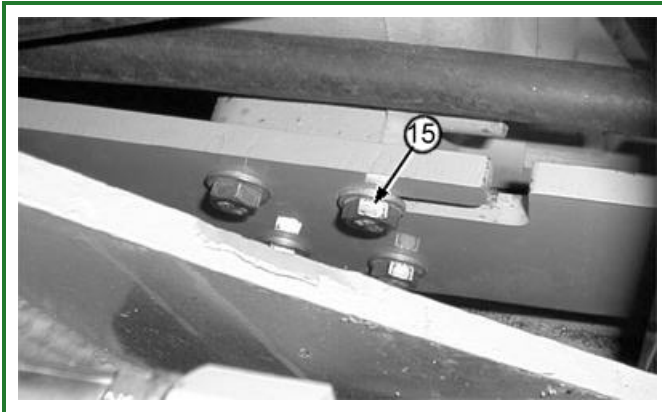

T117472B-UN: Side Rail Cap Screw in Slotted Area

LEGEND:

15 - Guide Cap Screw in Slotted Groove

Loosen guide cap screw in slotted groove (15). This is used to guide the engine out and back in.

19. Remove front and rear side rail to engine cap screws.

20. Lift engine forward and up between frame rails.

21. Remove wiring if necessary. [See Engine Harness \(W6\) Component Location](#) . (Group 9015-10.)

22.

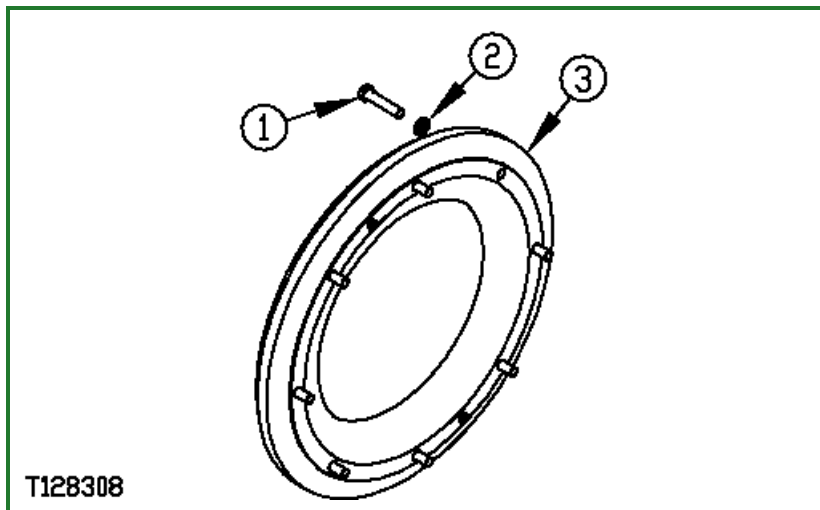

T128308-UN: Flywheel Ring

LEGEND:

- 1 - Cap Screw (8 used)
- 2 - Washer (8 used)
- 3 - Flywheel Ring

If equipped with hydraulic pump with drive through shaft the flywheel will have a flywheel ring (3), cap screws (1), and washers (2).

Apply thread lock and sealer (medium strength) to threads of cap screws (1). Tighten cap screws (1) to specification.

Item	Measurement	Specification
Engine		
Pump Flywheel Ring-to-Flywheel Housing Cap Screws	Torque	57 N·m 42 lb-ft

- 23. Install engine using side rail cap screws to guide engine in through slots aligning pump drive.
- 24. Install pump flywheel housing cap screws before removing pump support.
- 25. Remove pump support.
- 26. Install the remaining flywheel housing cap screws. Tighten cap screws to specification.

Item	Measurement	Specification
Engine		
Pump Flywheel Cover-to-Flywheel Housing Cap Screws	Torque	73 N·m 54 lb-ft

27.

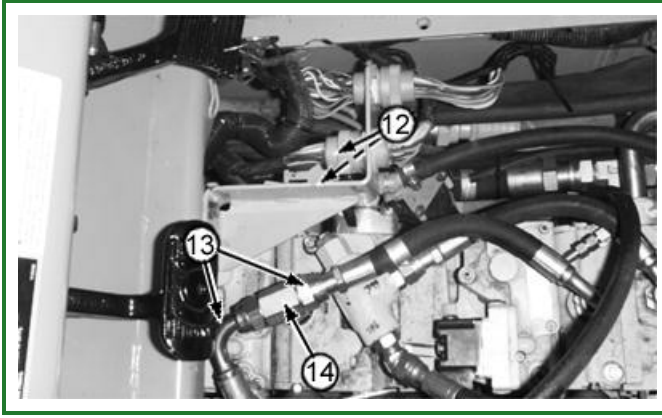

T117450B-UN: Engine Harness and Tee Fitting

LEGEND:

- 12 - Engine Harness Connector and (Red) Bulkhead Connector
- 13 - Cooler Bypass Hose (2 used)
- 14 - Tee Fitting

Install tee fitting (14). Connect cooler bypass hoses (13), engine harness connector and (red) bulkhead connector (12).

28.

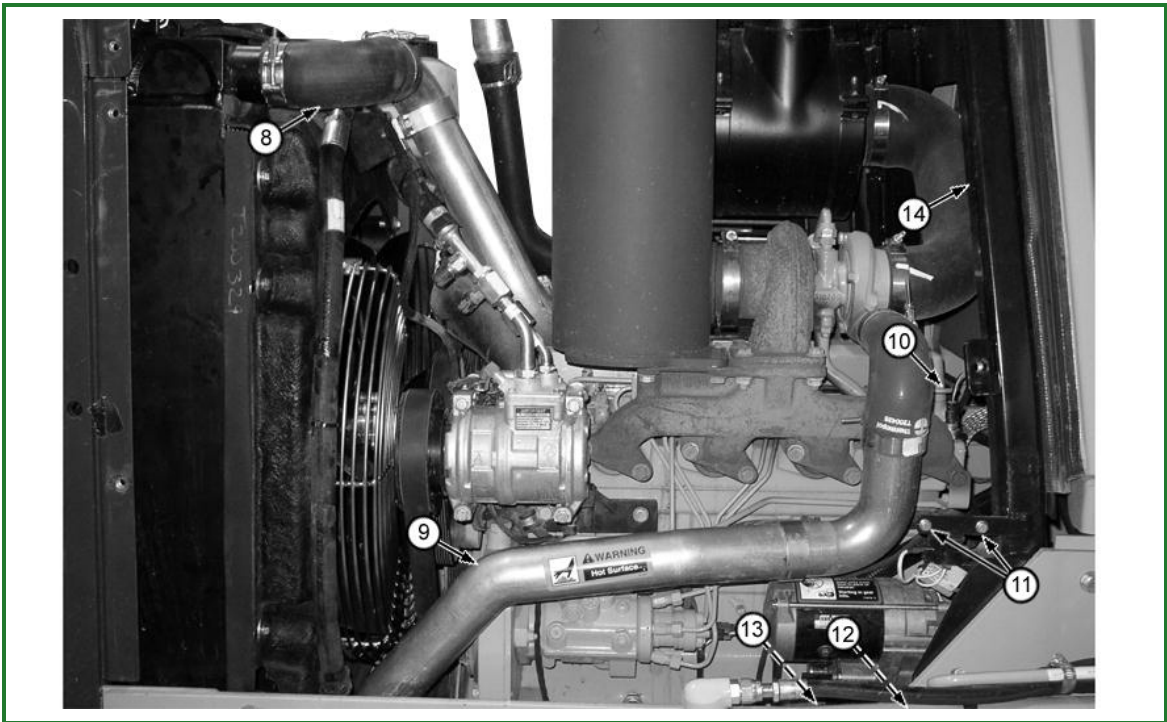

T193926A-UN: Engine (Left Side)

LEGEND:

- 8 - Upper Charge Air Cooler Hose
- 9 - Lower Charge Air Cooler Hose
- 10 - Fuel Return Line
- 11 - Start Relay Cap Screw (2 used)
- 12 - Ground Strap and Starter Ground Cable
- 13 - Start Solenoid Positive Cable
- 14 - Rear Hood Bracket with Air Cleaner

Install components (8—14).

29.

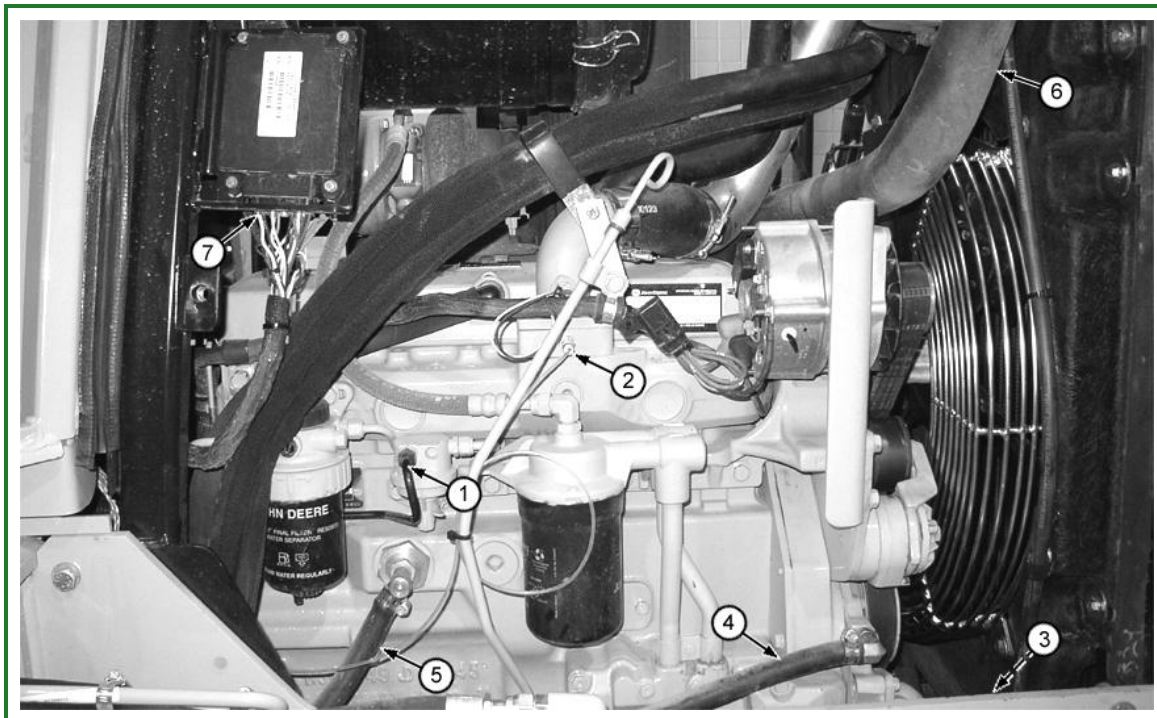

T193925A-UN: Engine (Right Side)

LEGEND:

- 1 - Fuel Supply Line
- 2 - Start Aid Line
- 3 - Lower Radiator Hose
- 4 - Return Heater Hose
- 5 - Supply Heater Hose
- 6 - Upper Radiator Hose
- 7 - Engine Control Unit (ECU) Connector

Install and connect components (1—7).

- 30. Install fan blade and shroud. See [Fan Blade and Shroud Remove and Install \(450J, 550J\)](#) or [Fan Blade and Shroud Remove and Install \(650J\)](#) . (Group 0510.)
- 31. Install floor plate and bottom guard plate.
- 32. Turn battery disconnect switch to ON.
- 33. Install hood and side shields. See [Hood Support and Engine Side Shields Remove and Install](#) . (Group 1910.)
- 34. Fill radiator with coolant.

Item	Measurement	Specification
Engine Coolant Capacity		11 L 3 gal

- 35. Bleed fuel system. See [Bleed the Fuel System](#) . (CTM331.)

Go to [Section_04:Group_0400](#)

TE14778,000000A-19-20030812

Engine Remove and Install

1.

⚠ CAUTION:

Explosive release of fluids from pressurized cooling system can cause serious burns.

Shut off engine. Only remove filler cap when cool enough to touch with bare hands. Slowly loosen cap to first stop to relieve pressure before removing completely.

**TS281-UN: Explosive Fluids**

Drain engine coolant. See [Miscellaneous—Specifications](#) . (Operator's Manual)

2. Remove engine side shields.
3. Remove hood. See [Hood Remove and Install](#) . (Group 1910.)
4. Turn battery disconnect switch to OFF.
5. Remove fan blade and shroud. See [Fan Blade and Shroud Remove and Install \(450J, 550J\)](#) or [Remove and Install Fan blade and Shroud \(650J\)](#) . (Group 0510.)

6.

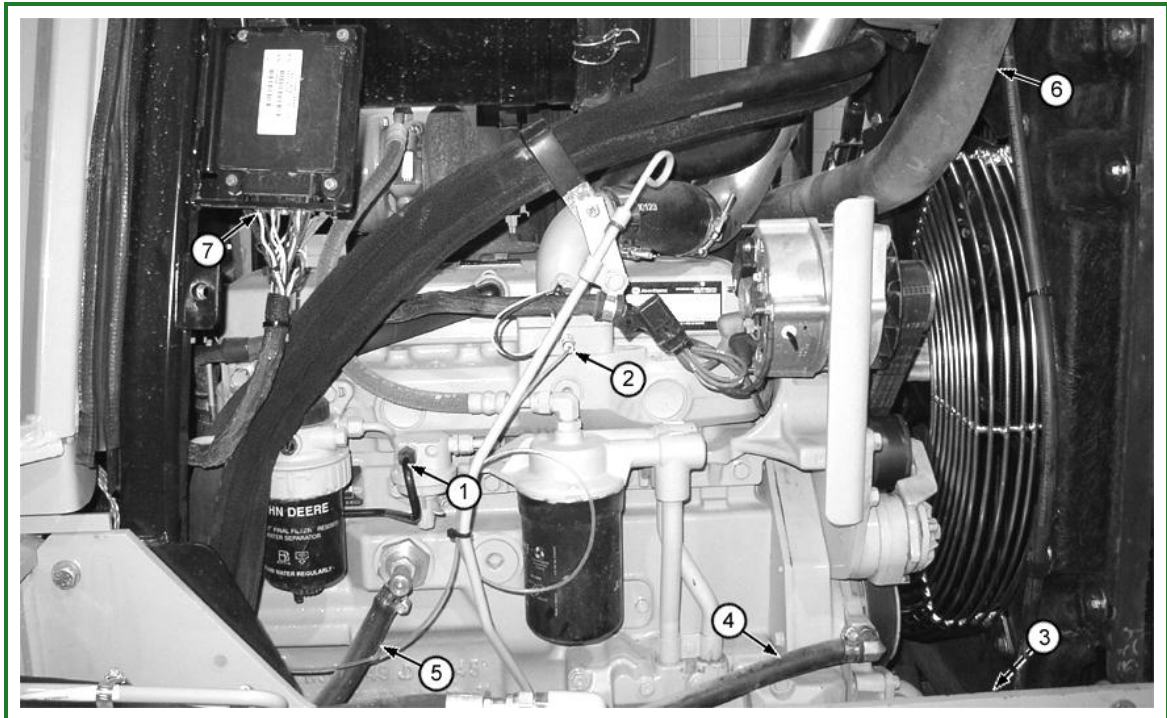

T193925A-UN: Engine (Right Side)

LEGEND:

- 1 - Fuel Supply Line
- 2 - Start Aid Line
- 3 - Lower Radiator Hose
- 4 - Return Heater Hose
- 5 - Supply Heater Hose
- 6 - Upper Radiator Hose
- 7 - Engine Control Unit (ECU) Connector

Disconnect components (1—7).

7.

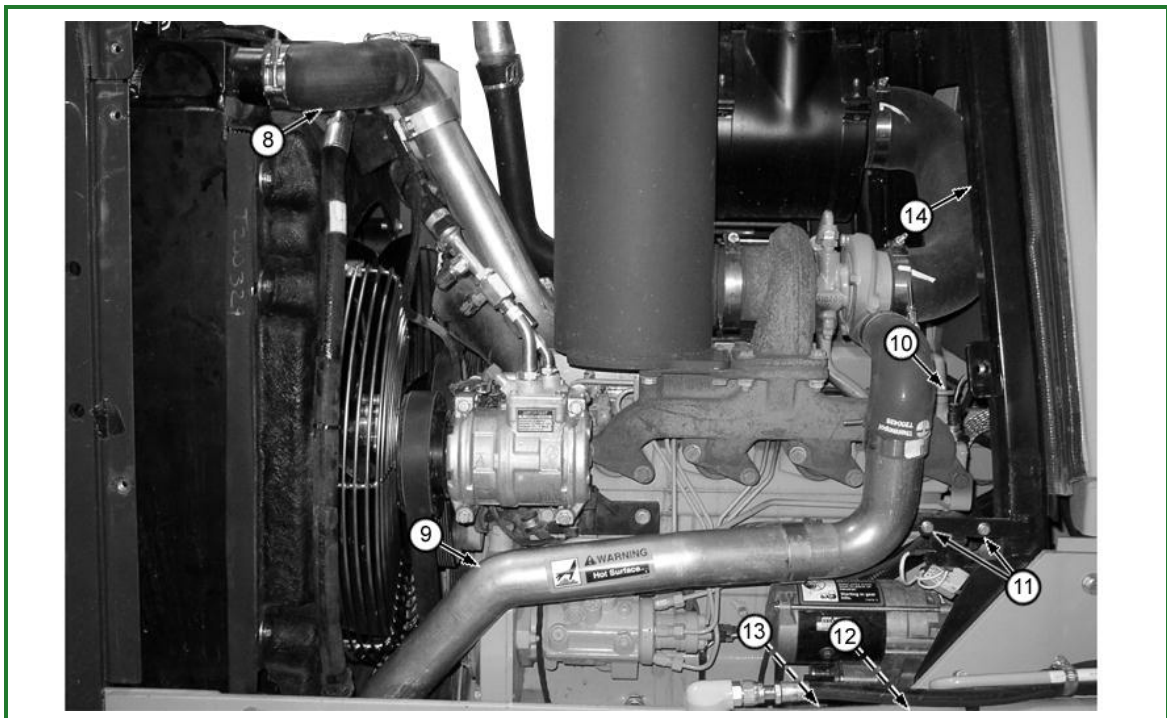

T193926A-UN: Engine (Left Side)

LEGEND:

- 8 - Upper Charge Air Cooler Hose
- 9 - Lower Charge Air Cooler Hose
- 10 - Fuel Return Line
- 11 - Start Relay Cap Screw (2 used)
- 12 - Ground Strap and Starter Ground Cable
- 13 - Start Solenoid Positive Cable
- 14 - Rear Hood Bracket with Air Cleaner

Disconnect components (8—14).

- 8. Remove muffler. See [Muffler Without Turbocharger Remove and Install](#) or [Muffler With Turbocharger Remove and Install](#) . (Group 0530.)
- 9. Remove rear support with air cleaner housing, hose, and Engine Control Unit (ECU).
- 10. If equipped, remove air conditioning compressor and set aside.

11.

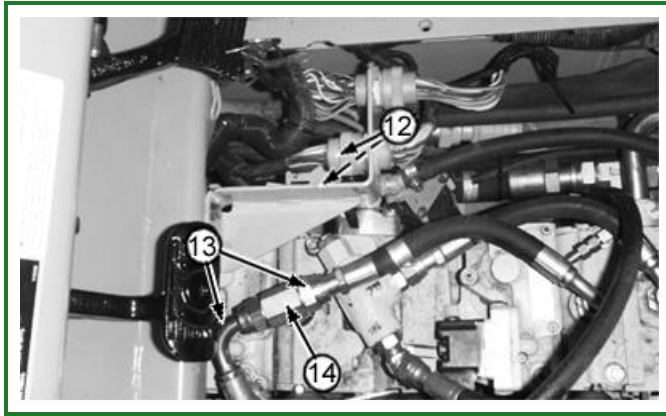

T117450B-UN: Engine Harness Connector and Lines

LEGEND:

- 12 - Engine Harness Connector and Red Bulkhead Connector
- 13 - Cooler Bypass Hose (2 used)
- 14 - Tee Fitting

Remove floor plate and disconnect cooler bypass hoses (13) from tee at pump case drain port.

- 12. Disconnect engine harness connector and red bulkhead connector (12).
- 13. Remove cap screws (12 used) from pump flywheel cover to engine.
- 14. Disconnect tee fitting (14) at pump case drain port.

15.



T117452B-UN: Pump Eyebolt



T117451B-UN: DFT1119 Pump Support

Drill and tap a 1-1/16 in. plug to accommodate a 1/2 in. shouldered lift eyebolt. Install plug and eyebolt in pump case drain port. Trim end of eyebolt so it is even with end of plug.

16. Support hydrostatic pumps using JT07184 Pump Support Bracket or a **DFT1119** [Pump Support Dealer Fabricated Tool. See Group 0999 for instructions to make tool.] and a small winch hoist.

17.

⚠ CAUTION:

Prevent possible crushing injury from removing engine. Use proper lifting equipment and safety precautions.

Item	Measurement	Specification
Engine Weight		500 kg 1102 lb



T117453B-UN: JDG23 Lifting Sling

Attach JDG23 Lifting Sling and a hoist to engine.

18.

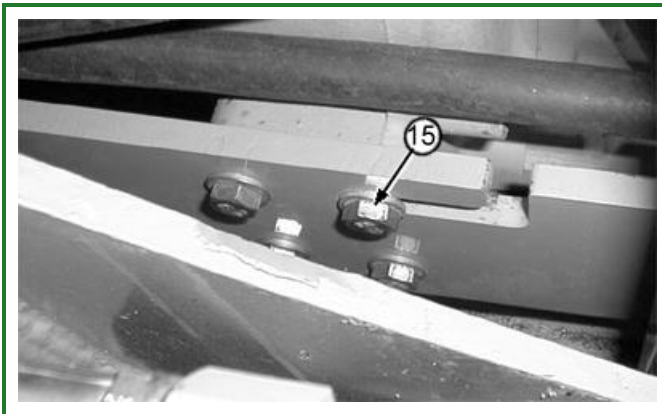

T117472B-UN: Side Rail Cap Screw in Slotted Area

LEGEND:

15 - Guide Cap Screw in Slotted Groove

Loosen guide cap screw in slotted groove (15). This is used to guide the engine out and back in.

19. Remove front and rear side rail to engine cap screws.

20. Lift engine forward and up between frame rails.

21. Remove wiring if necessary. [See Engine Harness \(W6\) Component Location](#) . (Group 9015-10.)

22.

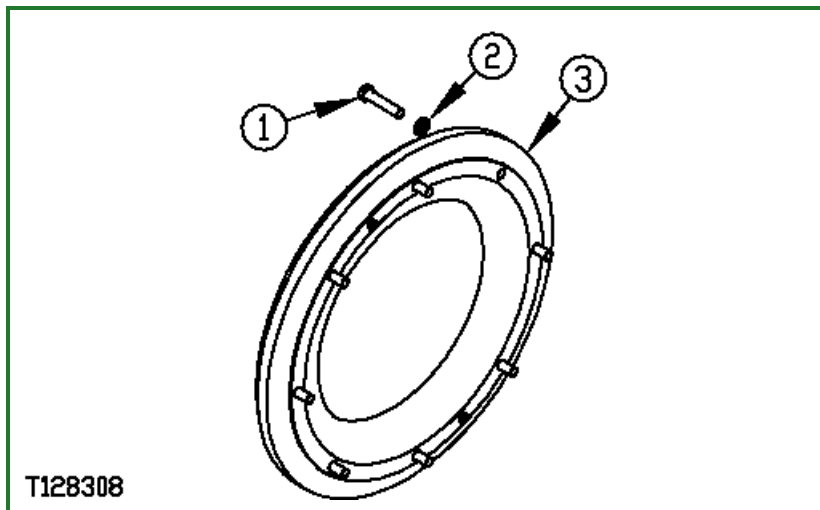

T128308-UN: Flywheel Ring

LEGEND:

- 1 - Cap Screw (8 used)
- 2 - Washer (8 used)
- 3 - Flywheel Ring

If equipped with hydraulic pump with drive through shaft the flywheel will have a flywheel ring (3), cap screws (1), and washers (2).

Apply thread lock and sealer (medium strength) to threads of cap screws (1). Tighten cap screws (1) to specification.

Item	Measurement	Specification
Engine		
Pump Flywheel Ring-to-Flywheel Housing Cap Screws	Torque	57 N·m 42 lb-ft

- 23. Install engine using side rail cap screws to guide engine in through slots aligning pump drive.
- 24. Install pump flywheel housing cap screws before removing pump support.
- 25. Remove pump support.
- 26. Install the remaining flywheel housing cap screws. Tighten cap screws to specification.

Item	Measurement	Specification
Engine		
Pump Flywheel Cover-to-Flywheel Housing Cap Screws	Torque	73 N·m 54 lb-ft

27.

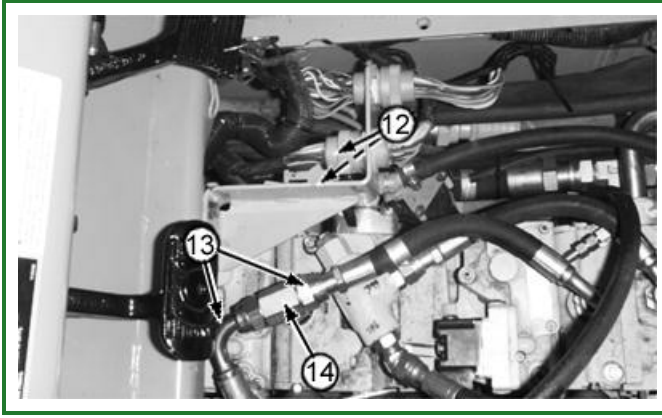

T117450B-UN: Engine Harness and Tee Fitting

LEGEND:

- 12 - Engine Harness Connector and (Red) Bulkhead Connector
- 13 - Cooler Bypass Hose (2 used)
- 14 - Tee Fitting

Install tee fitting (14). Connect cooler bypass hoses (13), engine harness connector and (red) bulkhead connector (12).

28.

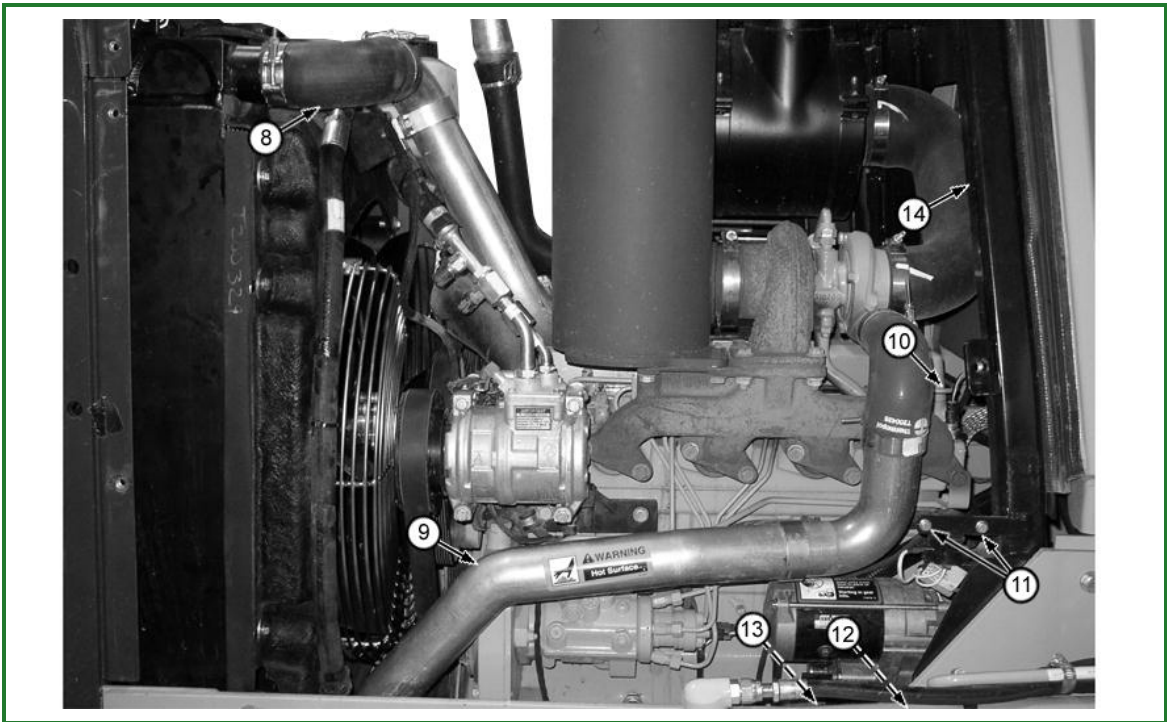

T193926A-UN: Engine (Left Side)

LEGEND:

- 8 - Upper Charge Air Cooler Hose
- 9 - Lower Charge Air Cooler Hose
- 10 - Fuel Return Line
- 11 - Start Relay Cap Screw (2 used)
- 12 - Ground Strap and Starter Ground Cable
- 13 - Start Solenoid Positive Cable
- 14 - Rear Hood Bracket with Air Cleaner

Install components (8—14).

29.

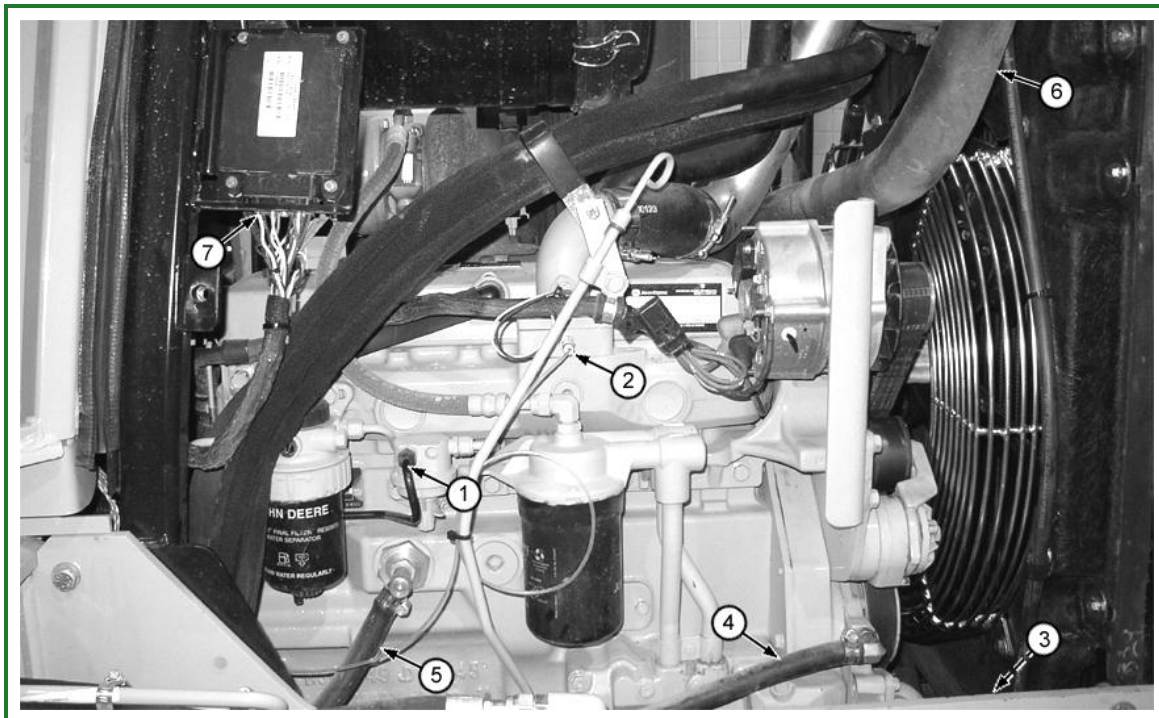

T193925A-UN: Engine (Right Side)

LEGEND:

- 1 - Fuel Supply Line
- 2 - Start Aid Line
- 3 - Lower Radiator Hose
- 4 - Return Heater Hose
- 5 - Supply Heater Hose
- 6 - Upper Radiator Hose
- 7 - Engine Control Unit (ECU) Connector

Install and connect components (1—7).

- 30. Install fan blade and shroud. See [Fan Blade and Shroud Remove and Install \(450J, 550J\)](#) or [Fan Blade and Shroud Remove and Install \(650J\)](#) . (Group 0510.)
- 31. Install floor plate and bottom guard plate.
- 32. Turn battery disconnect switch to ON.
- 33. Install hood and side shields. See [Hood Support and Engine Side Shields Remove and Install](#) . (Group 1910.)
- 34. Fill radiator with coolant.

Item	Measurement	Specification
Engine Coolant Capacity		11 L 3 gal

- 35. Bleed fuel system. See [Bleed the Fuel System](#) . (CTM331.)

Go to [Section_04:Group_0400](#)

TE14778,000000A-19-20030812

Section 05: Engine Auxiliary Systems

Group 0505: Cold Weather Starting Aids

Engine Coolant Heater Remove and Install

Start Aid Remove and Install

Starting Aid Solenoid Remove and Install

Group 0510: Radiator and Fan Shroud

Fan Blade and Shroud Remove and Install (450J, 550J)

Fan Blade and Shroud Remove and Install (650J)

Cooling Package Remove and Install (450J, 550J)

Cooling Package Remove and Install (650J)

Sand Shield Remove and Install

Group 0515: Engine Speed Control

Decelerator/Brake Pedal Remove and Install

Decelerator/Brake Pedal Disassemble and Assemble

Group 0520: Intake System

Air Cleaner Remove and Install 550J and 650J

Group 0530: External Exhaust System

Muffler Without Turbocharger Remove and Install

Muffler With Turbocharger Remove and Install

Group 0540: Mounting Frame

Engine and Power Train Mounting

Group 0560: External Fuel Supply System

Fuel Tank Remove and Install

Engine Coolant Heater Remove and Install

⚠ CAUTION:

TEST COOLANT HEATER ONLY WHEN HEATING ELEMENT IS IMMERSED IN LIQUID. Prevent possible injury from explosion. Do not plug coolant heater into electrical power unless heating element is immersed in liquid. Sheath could burst and result in injury.

Use a heavy-duty grounded cord to connect coolant heater to electrical power.

⚠ CAUTION:



TS281-UN: Explosive Fluids

Explosive release of fluids from pressurized cooling system can cause serious burns.

Shut off engine. Only remove filler cap when cool enough to touch with bare hands. Slowly loosen cap to relieve pressure before removing completely.

1. Drain coolant from radiator and engine block.

Item	Measurement	Specification
Engine Coolant Capacity		11 L 3 gal

2. Remove right side engine shield.

3.

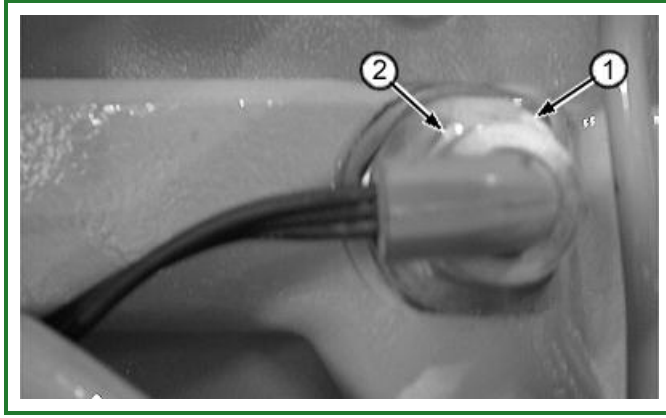

T117492B-UN: Adapter and Nut

LEGEND:

1 - Adapter

2 - Nut

Disconnect cord from heater. Loosen nut (2). Remove adapter (1) to remove heater element from cylinder block.

4.

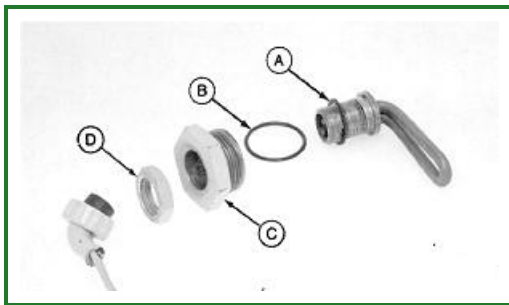

T87072-UN: Gasket, O-Ring, Adapter and Nut

LEGEND:

A - Gasket

B - O-Ring

C - Adapter

D - Nut

Install gasket (A) on heater element and O-ring (B) on adapter (C). Install heater element through adapter (C) and install nut (D), but do not tighten.

5. Install heater into cylinder block with element pointing towards the flywheel.

6. Tighten adapter (C).

7. Turn element clockwise and then counterclockwise until element contacts casting. Move element midway between contact points.

8. Hold element with a wrench and tighten lock nut (D) to specification.

Item	Measurement	Specification
Engine Coolant Heater Element Nut	Torque	34 N·m 25 lb-ft

9. Connect cord to heater. Install engine side shield.

10. Fill radiator and engine block with coolant.

Item	Measurement	Specification
Engine Coolant	Capacity	11 L 3 gal

Go to [Section_05:Group_0505](#)

CED,TX03399,5015-19-20130415

Engine Coolant Heater Remove and Install

⚠ CAUTION:

TEST COOLANT HEATER ONLY WHEN HEATING ELEMENT IS IMMERSED IN LIQUID. Prevent possible injury from explosion. Do not plug coolant heater into electrical power unless heating element is immersed in liquid. Sheath could burst and result in injury.

Use a heavy-duty grounded cord to connect coolant heater to electrical power.

⚠ CAUTION:



TS281-UN: Explosive Fluids

Explosive release of fluids from pressurized cooling system can cause serious burns.

Shut off engine. Only remove filler cap when cool enough to touch with bare hands. Slowly loosen cap to relieve pressure before removing completely.

1. Drain coolant from radiator and engine block.

Item	Measurement	Specification
Engine Coolant Capacity		11 L 3 gal

2. Remove right side engine shield.

3.

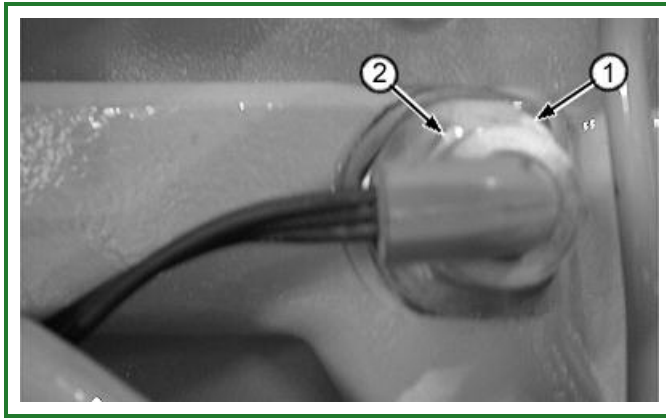

T117492B-UN: Adapter and Nut

LEGEND:

1 - Adapter

2 - Nut

Disconnect cord from heater. Loosen nut (2). Remove adapter (1) to remove heater element from cylinder block.

4.

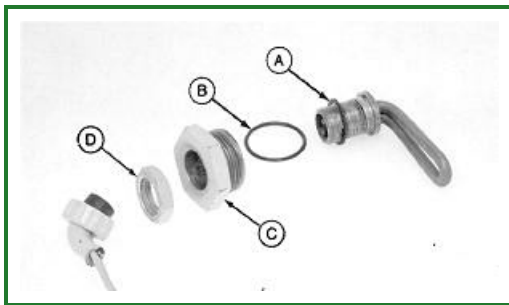

T87072-UN: Gasket, O-Ring, Adapter and Nut

LEGEND:

A - Gasket

B - O-Ring

C - Adapter

D - Nut

Install gasket (A) on heater element and O-ring (B) on adapter (C). Install heater element through adapter (C) and install nut (D), but do not tighten.

5. Install heater into cylinder block with element pointing towards the flywheel.

6. Tighten adapter (C).

7. Turn element clockwise and then counterclockwise until element contacts casting. Move element midway between contact points.

8. Hold element with a wrench and tighten lock nut (D) to specification.

Item	Measurement	Specification
Engine Coolant Heater Element Nut	Torque	34 N·m 25 lb-ft

9. Connect cord to heater. Install engine side shield.

10. Fill radiator and engine block with coolant.

Item	Measurement	Specification
Engine Coolant	Capacity	11 L 3 gal

Go to [Section_05:Group_0505](#)

CED,TX03399,5015-19-20130415

Start Aid Remove and Install

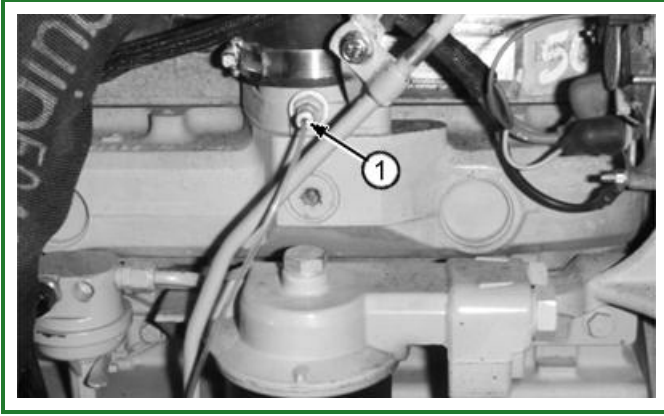

T117494B-UN: Starting Aid Tube

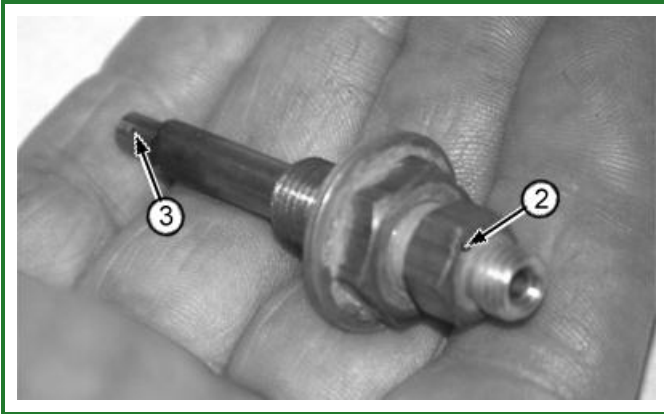

T117496B-UN: Nozzle Holder

LEGEND:

- 1 - Starting Aid Tube
- 2 - Red Dot for Nozzle Installation
- 3 - Orifice

1. Remove right engine side shield
2. Disconnect starting aid tube (1).

3.

NOTE:

Mark location of red dot when removing.

Remove nozzle holder from air inlet.

4. Clean or replace nozzle holder as required.

5.

NOTE:

Red dot (2) on nozzle holder must be installed at the 12 o'clock position, facing the incoming air flow. Nozzle orifice (3) needs to be in the path of the air flow to disperse fluid for quick start of engine.

Install nozzle and connect starting aid tube.

6. Install engine side shield

Go to [Section_05:Group_0505](#)

KV70328,0000077-19-20060614

Starting Aid Solenoid Remove and Install

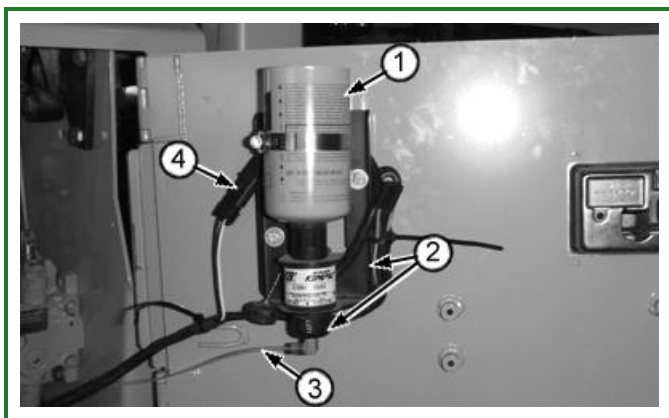

T117493B-UN: Starting Aid Solenoid

LEGEND:

- 1 - Solenoid Fluid Can
- 2 - Bracket and Solenoid
- 3 - Starting Aid Tube
- 4 - Wiring Lead Connector

1. Open right side access door.
2. Remove starting fluid can (1).
3. Disconnect wiring lead connector (4) and starting aid tube (3).
4. Remove bracket and solenoid (2).
5. Install solenoid and bracket.
6. Connect starting aid tube and wiring lead connector (4).

Go to [Section_05:Group_0505](#)

KV70328,0000078-19-20060614

Fan Blade and Shroud Remove and Install (450J, 550J)

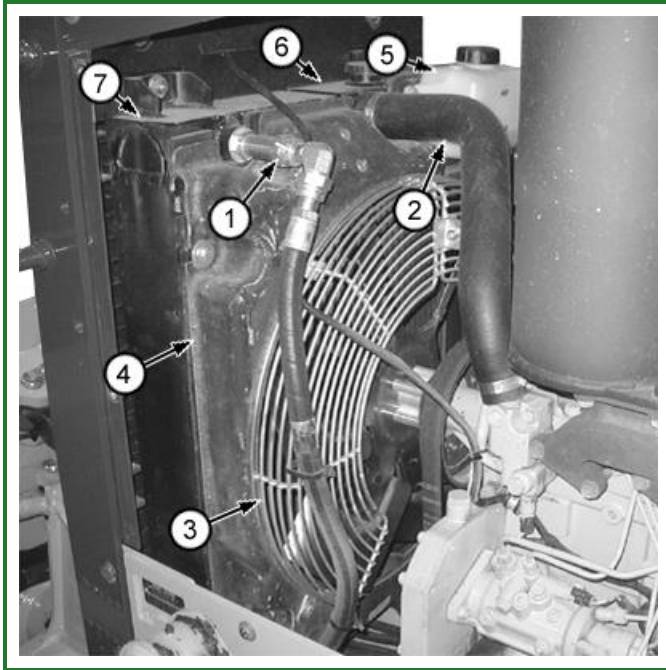

T197451A-UN: Cooling Package (450J, 550J) (Canopy Option Shown)

LEGEND:

- 1 - Upper Oil Cooler Hose
- 2 - Radiator Hose
- 3 - Fan Guard
- 4 - Fan Shroud
- 5 - Radiator Overflow Reservoir
- 6 - Radiator
- 7 - Oil Cooler

1. Remove engine side shields from both sides of machine.
2. Release belt tension adjuster to loosen belt.
3. Disconnect air conditioning compressor wiring harness (4).
4. Remove cap screws (5) and set compressor aside.
5. Remove fan guard (3).
6. Remove fan blade, spacer, and pulley.
7. Remove hood. [See Hood Remove and Install](#) . (Group 1910.)
8. Remove fan shroud.
9. Disconnect upper oil cooler hose (1), radiator hose (2), and coolant over flow tube from coolant reservoir (5).
10. Remove cap screws and rotate fan shroud 90° upward.
11. Install fan shroud (4).
12. Connect upper cooler hose (1), radiator hose (2), and coolant over flow tube.

13.

NOTE:

Use two M10 x 50 mm cap screws to draw in spacer and pulley to fan drive hub to aid in assembly.

Install fan pulley, spacer and fan. Tighten fan cap screws to specification.

Item	Measurement	Specification
Fan Blade Cap Screws	Torque	73 N·m 54 lb-ft

14. Install fan guard. Tighten cap screws to specification.

Item	Measurement	Specification
Fan Guard Cap Screws	Torque	16—19 N·m 142—168 lb-in.

15. Install compressor. Tighten cap screws to specification.

Item	Measurement	Specification
Compressor Cap Screws	Torque	35 N·m 26 lb-ft

16. Connect air conditioning compressor wiring harness.

17. Install fan belt and engine side shields.

18. Install hood. [See Hood Remove and Install](#) . (Group 1910.)

Go to [Section_05:Group_0510](#)

DW09104,00000D6-19-20040123

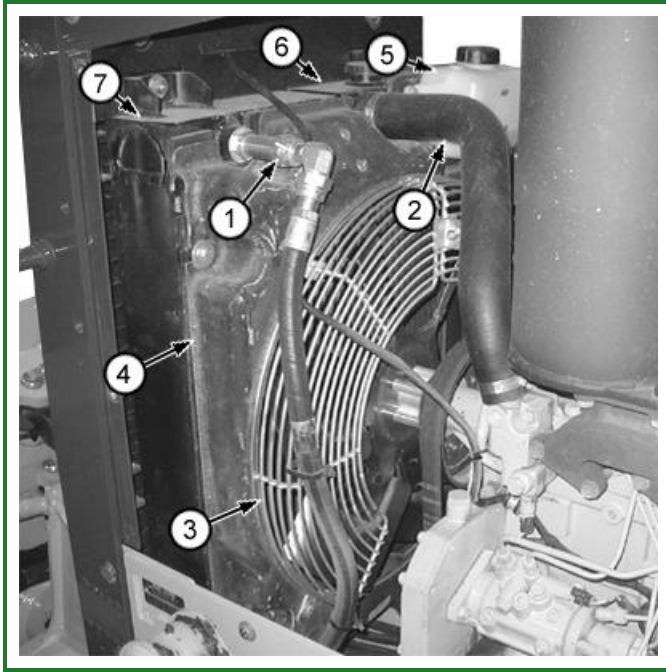
Fan Blade and Shroud Remove and Install (450J, 550J)**T197451A-UN: Cooling Package (450J, 550J) (Canopy Option Shown)****LEGEND:**

- 1 - Upper Oil Cooler Hose
- 2 - Radiator Hose
- 3 - Fan Guard
- 4 - Fan Shroud
- 5 - Radiator Overflow Reservoir
- 6 - Radiator
- 7 - Oil Cooler

1. Remove engine side shields from both sides of machine.
2. Release belt tension adjuster to loosen belt.
3. Disconnect air conditioning compressor wiring harness (4).
4. Remove cap screws (5) and set compressor aside.
5. Remove fan guard (3).
6. Remove fan blade, spacer, and pulley.
7. Remove hood. [See Hood Remove and Install](#) . (Group 1910.)
8. Remove fan shroud.
9. Disconnect upper oil cooler hose (1), radiator hose (2), and coolant over flow tube from coolant reservoir (5).
10. Remove cap screws and rotate fan shroud 90° upward.
11. Install fan shroud (4).
12. Connect upper cooler hose (1), radiator hose (2), and coolant over flow tube.

13.

NOTE:

Use two M10 x 50 mm cap screws to draw in spacer and pulley to fan drive hub to aid in assembly.

Install fan pulley, spacer and fan. Tighten fan cap screws to specification.

Item	Measurement	Specification
Fan Blade Cap Screws	Torque	73 N·m 54 lb-ft

14. Install fan guard. Tighten cap screws to specification.

Item	Measurement	Specification
Fan Guard Cap Screws	Torque	16—19 N·m 142—168 lb-in.

15. Install compressor. Tighten cap screws to specification.

Item	Measurement	Specification
Compressor Cap Screws	Torque	35 N·m 26 lb-ft

16. Connect air conditioning compressor wiring harness.

17. Install fan belt and engine side shields.

18. Install hood. [See Hood Remove and Install](#) . (Group 1910.)

Go to [Section_05:Group_0510](#)

DW09104,00000D6-19-20040123

Fan Blade and Shroud Remove and Install (650J)

1. Remove engine side shields. Remove hood. [See Hood Remove and Install](#) . (Group 1910.)
2. Release belt tension adjuster to loosen belt.

3.

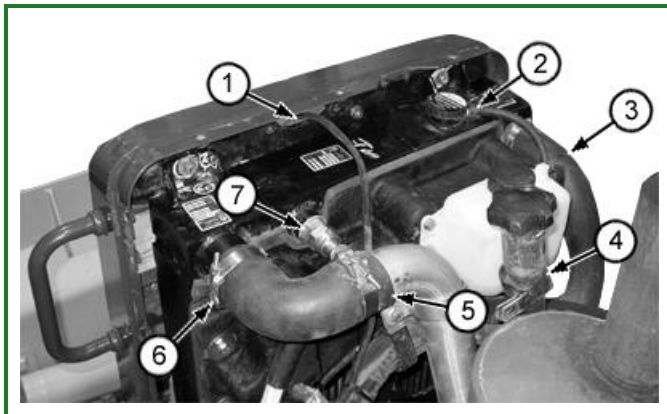

T193954A-UN: Remove Hoses

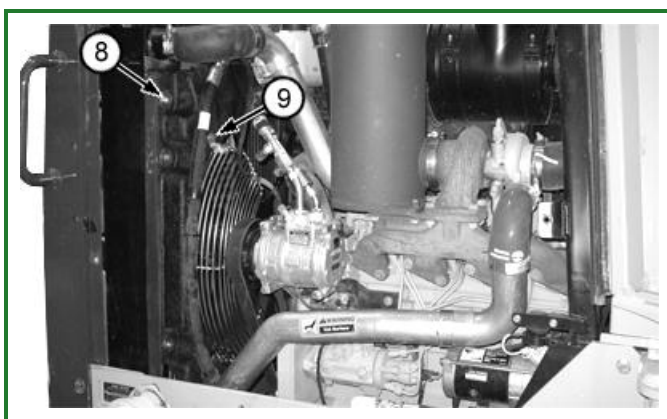

T193957A-UN: Remove Fan Guards and Cap Screws

LEGEND:

- 1 - Wiring Harness
- 2 - Radiator Overflow Hose
- 3 - Radiator Hose
- 4 - Oil Fill Hose Bracket
- 5 - Charge Air Hose Bracket
- 6 - Charge Air Hose
- 7 - Hydrostatic Cooler Line
- 8 - Fan Shroud Cap Screw
- 9 - Fan Guard Cap Screw

Remove fan guard cap screws (9). Remove fan guards.

4. Remove fan blade, spacer, and pulley.
5. Remove engine oil fill hose bracket (4).
6. Drain engine coolant.

Item	Measurement	Specification
Engine Coolant	Capacity approximate	13.25 L 3.5 gal

7. Remove hoses (2, 3, 6, and 7). Cap and plug all openings
8. Disconnect wiring harness (1) from horn and lights. Move wiring harness aside.
9. Remove grille. [See Grille and Grille Housing Removal](#) . (Group 1921.)
10. Remove shroud cap screws (8). Remove shroud. Repair or replace as necessary.

11.

NOTE:

If replacing shroud, coolant overflow bottle must be installed on new shroud

Install shroud cap screws (8).

12. Connect wiring harness (1) to horn and lights.
13. Install hoses (2, 3, 6, and 7).
14. Fill engine coolant.

Item	Measurement	Specification
Engine Coolant	Capacity approximate	13.25 L 3.5 gal

15. Install engine oil fill hose bracket (4).

16.

NOTE:

To aid in assembly, use two M10 x 50 mm cap screws to draw in spacer and pulley to fan drive hub.

Install fan pulley, spacer and fan. Tighten fan cap screws to specification.

Item	Measurement	Specification
Fan Blade Cap Screws	Torque	73 N·m 54 lb-ft

17. Install fan guard. Tighten cap screws to specification.

Item	Measurement	Specification
Fan Guard Cap Screws	Torque	16—19 N·m 142—168 lb-in.

18. Install belt.
19. Install engine side shields Install hood. [See Hood Remove and Install](#) . (Group 1910.)

Go to [Section_05:Group_0510](#)

DW09104,00000D7-19-20040123

Cooling Package Remove and Install (450J, 550J)

⚠ CAUTION:

Explosive release of fluids from pressurized cooling system can cause serious burns.

Shut off engine. Only remove filler cap when cool enough to touch with bare hands. Slowly loosen cap to first stop to relieve pressure before removing completely.

1. Remove grille and grille housing. See [Grille and Grille Housing Removal](#) . (Group 1921.)
2. Drain engine coolant. See [Drain the Cooling System](#) . (Operator's Manual.)
3. Apply vacuum to hydrostatic reservoir.

4.

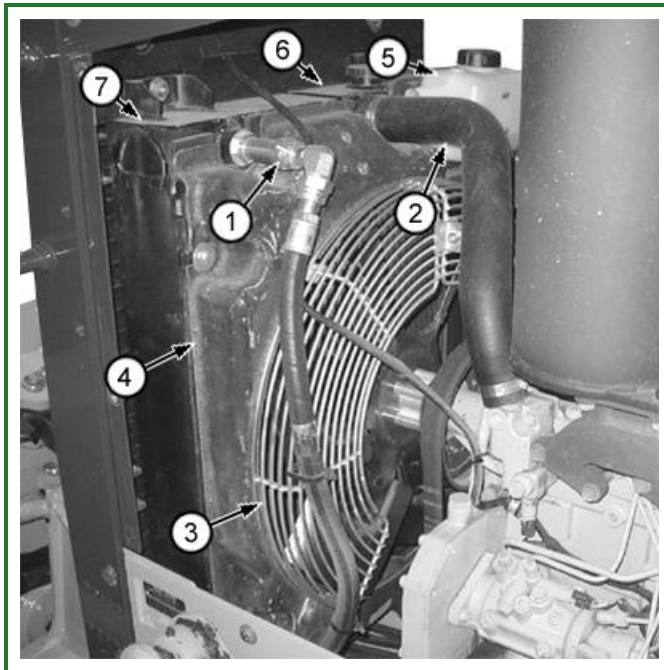
**T197451A-UN: Cooling Package****LEGEND:**

- 1 - Oil Cooler Hoses (upper hose shown)
- 2 - Upper Radiator Hose
- 3 - Fan Guard
- 4 - Fan Shroud
- 5 - Coolant Overflow Reservoir
- 6 - Radiator
- 7 - Oil Cooler

Remove oil cooler hose (1). Cap and plug all openings.

5. Remove upper radiator hose (2) and lower radiator hoses. Cap and plug all openings.
6. Remove fan guard (3).

7.

⚠ CAUTION:

Prevent possible injury from crushing. Heavy component, use appropriate lifting device.

Remove two bottom cap screws from cooling package and secure with appropriate lifting device.

Item	Measurement	Specification
Cooling Package Weight—approximate		57 kg 125 lb

8. Raise cooling package slightly and remove rubber mounts from bottom of radiator to clear frame. Remove cooling package and shroud as assembly.
9. Remove radiator shroud and overflow reservoir if replacing entire cooling package.
10. Install cooling package and shroud (4).
11. Install lower rubber mounts and tighten cap screws to specification.

Item	Measurement	Specification
Lower Mounting Cap Screws	Torque	33 N·m 24 lb·ft

12. Install cooling package mounting hardware (if removed).

Item	Measurement	Specification
Bracket-to-Radiator Cap Screws	Torque	73 N·m 54 lb·ft
Bracket-to-Oil Cooler Cap Screws	Torque	73 N·m 54 lb·ft

13. Install grille housing. [See Grille and Grille Housing Installation](#) . (Group 1921.)
14. Install cooling package bracket-to-grille housing. Tighten to specification.

Item	Measurement	Specification
Upper Cooling Package Bracket-to-Grille Housing Cap Screw	Torque	58 N·m 43 lb·ft

15. Install fan guard (3). Tighten cap screws to specification.

Item	Measurement	Specification
Fan Guard Cap Screws	Torque	16—19 N·m 141—168 lb·in

16. Install upper radiator hose (2) and lower radiator hoses.
17. Connect oil cooler hoses (1) and fill radiator with coolant. [See Fill the Cooling System](#) . (Operator's Manual.) Also, [see 450J-LT and 450J-LGP Crawler Dozer Drain and Refill Capacities](#) or [see 550J-LT and 550J-LGP Crawler Dozer Drain and Refill Capacities](#) . (Operator's Manual.)

Go to [Section_05:Group_0510](#)

DW09104,00000D9-19-20171012

Cooling Package Remove and Install (650J)

⚠ CAUTION:



TS281-UN: Explosive Fluid

Explosive release of fluids from pressurized cooling system can cause serious burns.

***Shut off engine. Only remove filler cap when cool enough to touch with bare hands.
Slowly loosen cap to first stop to relieve pressure before removing completely.***

1.

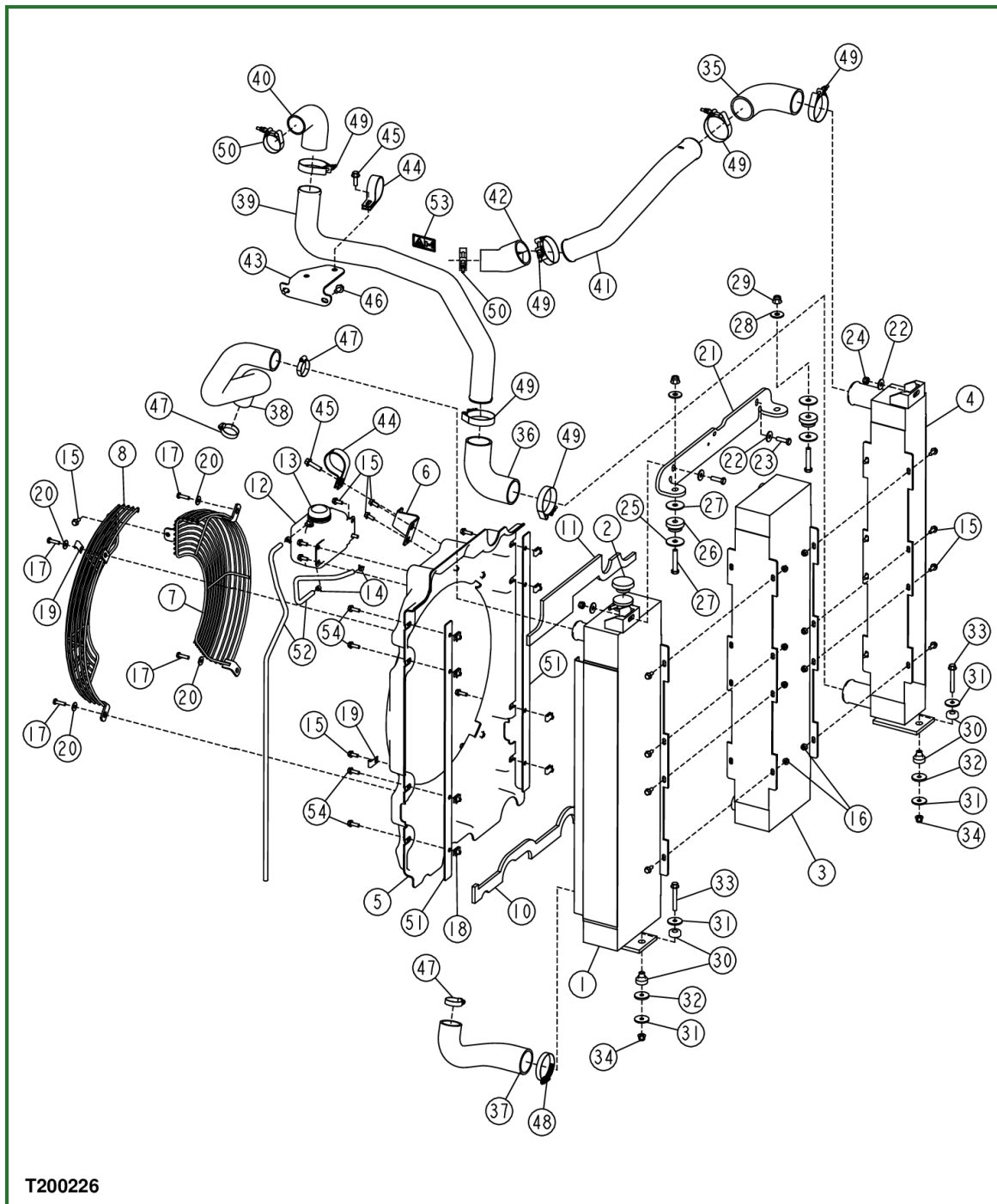

T200226-UN: Cooling System (650J)

LEGEND:

- 1 - Radiator
- 2 - Filler Cap
- 3 - Oil Cooler
- 4 - Air Cooler
- 5 - Shroud
- 6 - Bracket
- 7 - Guard
- 8 - Guard
- 9 - Washer (8 used)
- 10 - Deflector
- 11 - Deflector
- 12 - Tank
- 13 - Filler Cap

- 14 - Clip (3 used)
- 15 - Screw (24 used)
- 16 - Flange Nut (16 used)
- 17 - Cap Screw (4 used)
- 18 - Nut (8 used)
- 19 - Clamp (2 used)
- 20 - Washer (4 used)
- 21 - Bracket
- 22 - Washer (4 used)
- 23 - Cap Screw (2 used)
- 24 - Lock Washer (2 used)
- 25 - Nut (4 used)
- 26 - Isolator (2 used)
- 27 - Cap Screw (2 used)
- 28 - Washer (2 used)
- 29 - Lock Nut (2 used)
- 30 - Isolator (2 used)
- 31 - Washer (4 used)
- 32 - Washer (2 used)
- 33 - Cap Screw (2 used)
- 34 - Lock Nut (2 used)
- 35 - Hose
- 36 - Screw
- 37 - Radiator Hose
- 38 - Radiator Hose
- 39 - Tube
- 40 - Hose
- 41 - Tube
- 42 - Air Cooler Hose
- 43 - Bracket
- 44 - Clamp (2 used)
- 45 - Screw
- 46 - Screw (2 used)
- 47 - Clamp (3 used)
- 48 - Hose Clamp
- 49 - Clamp (6 used)
- 50 - Clamp (2 used)
- 51 - Strip (2 used)
- 52 - Bulk Hose
- 53 - Label
- 54 - Screw (8 used)

Remove engine side shields. Remove hood. [See Hood Remove and Install](#) . (Group 1910.)

2. Drain engine coolant. [See Drain the Cooling System](#) . (Operator's Manual.)
3. Remove grille and grille housing. [See Grille and Grille Housing Removal](#) . (Group 1921.)
4. Apply vacuum to hydrostatic reservoir.

5. Remove oil cooler hoses. Cap and plug all openings.
6. Remove fan blade and shroud. [See Fan Blade and Shroud Remove and Install \(650J\)](#) . (Group 0510.)
7. Remove upper and lower radiator hoses. Cap and plug all openings.
8. Remove hydrostatic oil cooler hose. Cap and plug all openings.

9.

⚠ CAUTION:

Prevent possible crushing injury from heavy component. Use appropriate lifting device.

10.

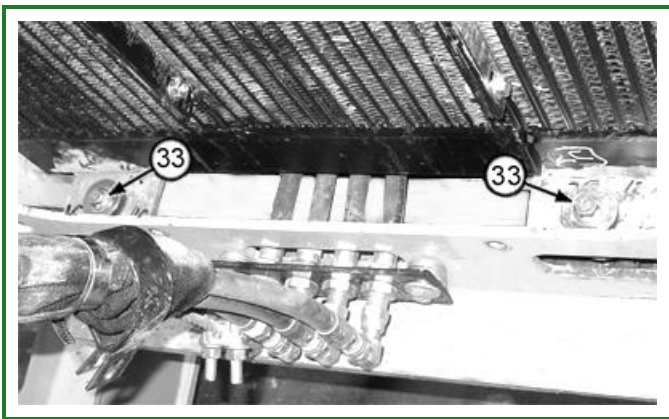

T193969A-UN: Bottom Mount Cap Screws

LEGEND:

33 - Cap Screw (2 used)

Remove two bottom mount cap screws (33).

11. Remove two bottom cap screws from cooling package and secure with appropriate lifting device.

Item	Measurement	Specification
Cooling Package Weight—approximate		57 kg 125 lb

12. Raise cooling package slightly and remove rubber mounts from bottom of radiator to clear frame.
13. Remove radiator shroud and overflow reservoir, if replacing entire cooling package.
14. Remove cooling package. Repair or replace as necessary.

15.

⚠ CAUTION:

Prevent possible crushing injury from heavy component. Use appropriate lifting device.

Install cooling package.

16. Hoist cooling package into position. Install bottom mount cap screws (33).
17. Install lower rubber mounts and tighten cap screws to specification.

Item	Measurement	Specification
Lower Mounting Cap Screws	Torque	33 N·m 25 lb·ft

18. Install cooling package mounting hardware (if removed).

Item	Measurement	Specification
Bracket-to-Radiator Cap Screws	Torque	73 N·m 54 lb·ft

19. Install hydrostatic cooler hoses. Cap and plug all openings.
20. Install fan blade and shroud. [See Fan Blade and Shroud Remove and Install \(650J\)](#) . (Group 0510.)
21. Install grille and grille housing. [See Grille and Grille Housing Installation](#) . (Group 1921.)
22. Install cooling package bracket-to-grille housing. Tighten to specification.

Item	Measurement	Specification
Upper Cooling Package Bracket-to-Grille Housing Cap Screw	Torque	58 N·m 43 lb·ft

23. Install hood. [See Hood Remove and Install](#) . (Group 1910.) Install engine side shields.
24. Install upper and lower radiator hoses.
25. Connect oil cooler hoses and fill radiator with coolant. [See Fill the Cooling System](#) and [see 650J, 650J-LGP and 650J-XLT Crawler Dozer Drain and Refill Capacities](#) . (Operator's Manual.)

Go to [Section_05:Group_0510](#)

DW09104,00000DA-19-20171012

Sand Shield Remove and Install

1.

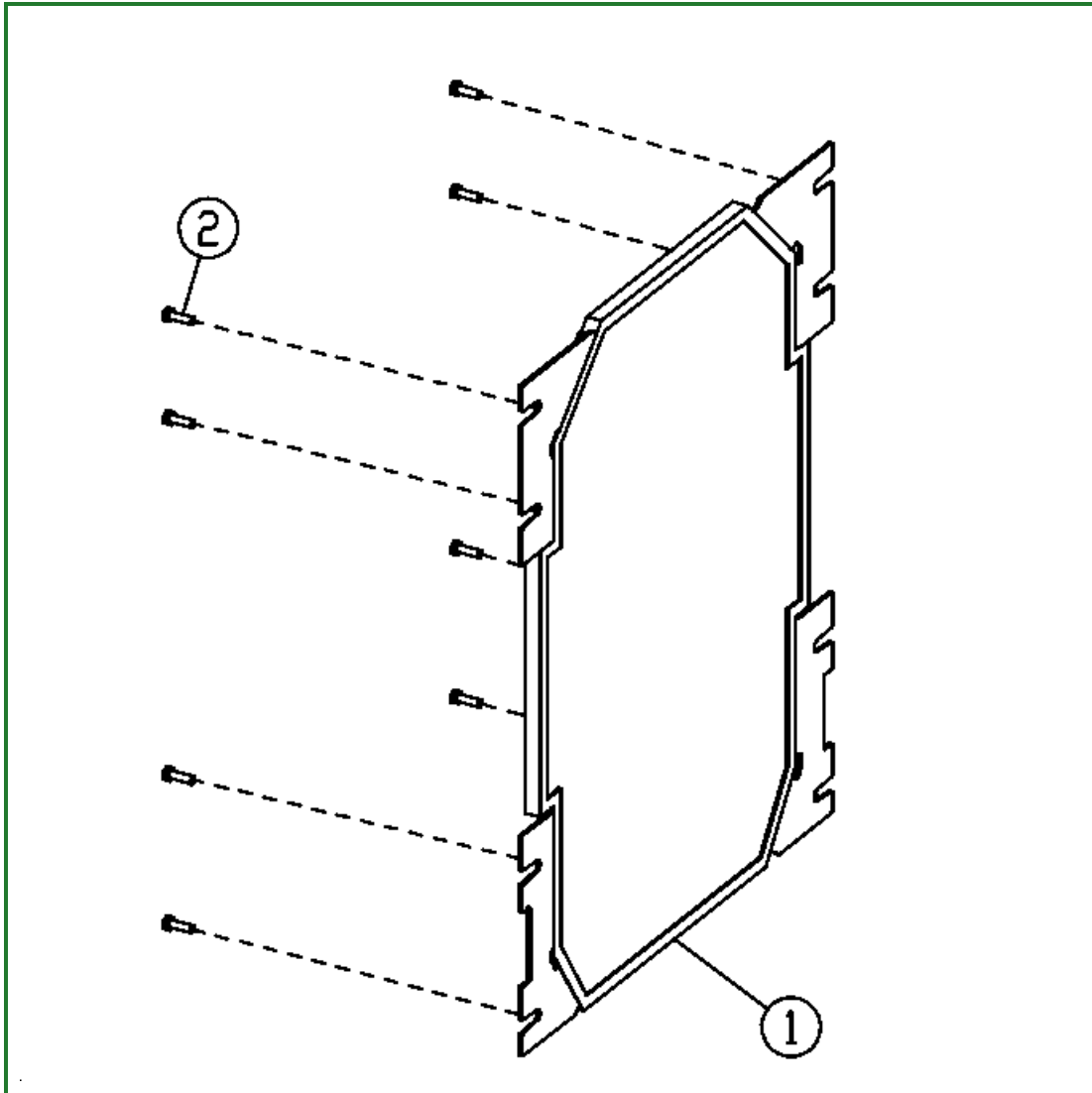

T193857-UN: Sand Shield (650J shown)

LEGEND:

1 - Sand Shield

2 - Cap Screw (8 used)

Remove engine side shields.

2. Remove hood. [See Hood Remove and Install](#) . (Group 1910.)
3. Remove fan blade and shroud. [See Fan Blade and Shroud Remove and Install \(450J, 550J\)](#) (Group 1921) or [Fan Blade and Shroud Remove and Install \(650J\)](#) . (Group 1921.)
4. Repair or replace sand shield as necessary.
5. Install fan blade and shroud. [See Fan Blade and Shroud Remove and Install \(450J, 550J\)](#) (Group 1921) or [Fan Blade and Shroud Remove and Install \(650J\)](#) . (Group 1921.)
6. Install engine side shields. Install Hood [See Hood Remove and Install](#) . (Group 1910.)

Go to [Section_05:Group_0510](#)

CED,OUO1066,252-19-20030808

Decelerator/Brake Pedal Remove and Install

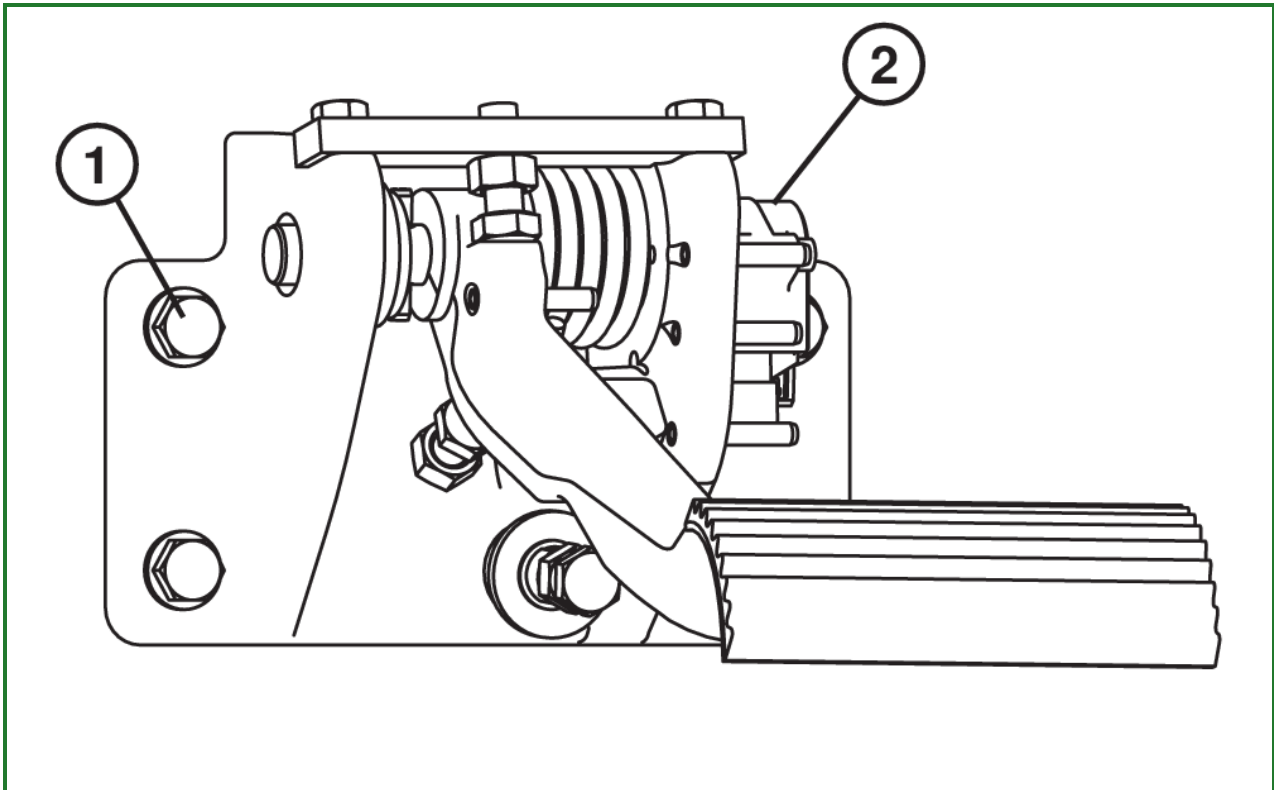
**T199889-UN: Decelerator Pedal Remove and Install****LEGEND:**

1 - Cap Screw (4 used)

2 - Decelerator Sensor

1. Loosen mounting cap screws (1).
2. Disconnect harness to decelerator sensor (2).
3. Remove cap screws and assembly.
4. Inspect and replace parts as necessary.

5. **NOTE:**

When installing assembly, verify that the round dust seal is in place on rear of support.

Install assembly and tighten cap screws to specification.

Item	Measurement	Specification
Decelerator Mounting Cap Screws	Torque	73 N·m 54 lb-ft

6. Connect harness to decelerator sensor.

Go to [Section_05:Group_0515](#)

MF82180,00001DA-19-20040507

Decelerator/Brake Pedal Remove and Install

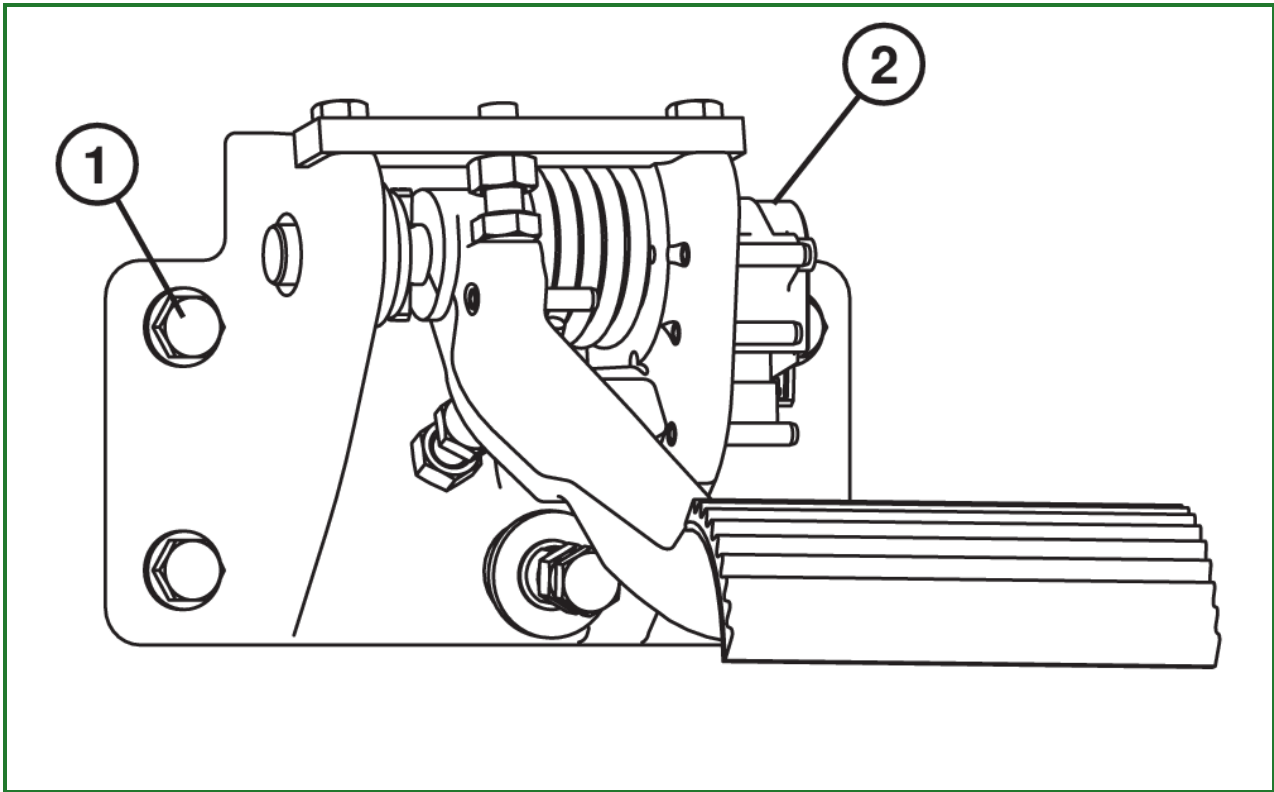
**T199889-UN: Decelerator Pedal Remove and Install****LEGEND:**

1 - Cap Screw (4 used)

2 - Decelerator Sensor

1. Loosen mounting cap screws (1).
2. Disconnect harness to decelerator sensor (2).
3. Remove cap screws and assembly.
4. Inspect and replace parts as necessary.

5. **NOTE:**

When installing assembly, verify that the round dust seal is in place on rear of support.

Install assembly and tighten cap screws to specification.

Item	Measurement	Specification
Decelerator Mounting Cap Screws	Torque	73 N·m 54 lb-ft

6. Connect harness to decelerator sensor.

Go to [Section_05:Group_0515](#)

MF82180,00001DA-19-20040507

Decelerator/Brake Pedal Disassemble and Assemble

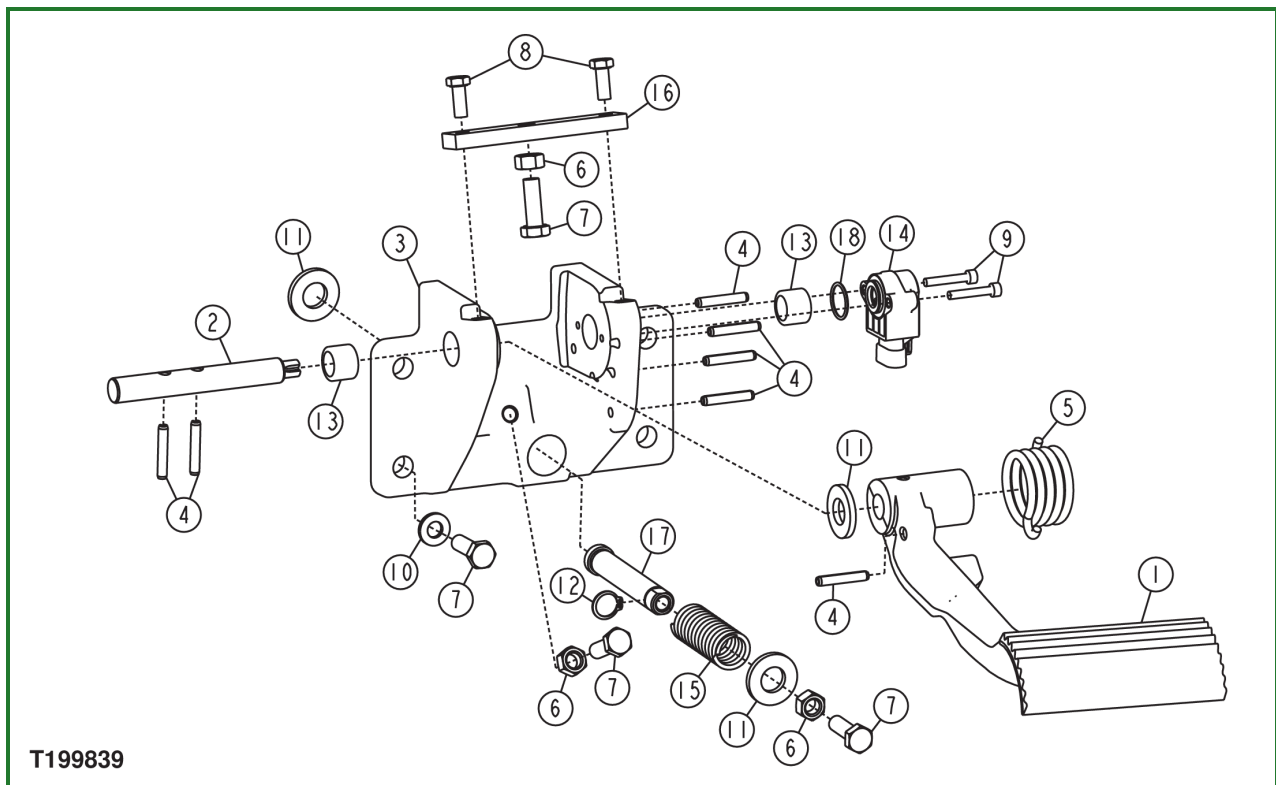

T199839-UN: Decelerator Pedal Exploded View

LEGEND:

- 1 - Pedal
- 2 - Shaft
- 3 - Support
- 4 - Spring Pin (7 used)
- 5 - Torsion Spring
- 6 - Nut (3 used)
- 7 - Cap Screw (7 used)
- 8 - Cap Screw (2 used)
- 9 - Hex Socket Head Screw (2 used)
- 10 - Washer (4 used)
- 11 - Washer (3 used)
- 12 - Snap Spring
- 13 - Needle Bearing (2 used)
- 14 - Decelerator Sensor
- 15 - Spring
- 16 - Stop Plate
- 17 - Pin Fastener
- 18 - O-Ring

1. Remove assembly from machine. See [Decelerator/Brake Pedal Remove and Install](#) . (Group 0515.)
2. Remove hex socket head cap screws (9) securing decelerator sensor.
3. Remove decelerator sensor (14) and O-ring (18).

4.

⚠ CAUTION:

Decelerator pedal is under spring pressure. Removing stop plate without relieving spring pressure can cause bodily injury. Relieve spring pressure by slowly loosening cap screws and holding pressure against pedal.

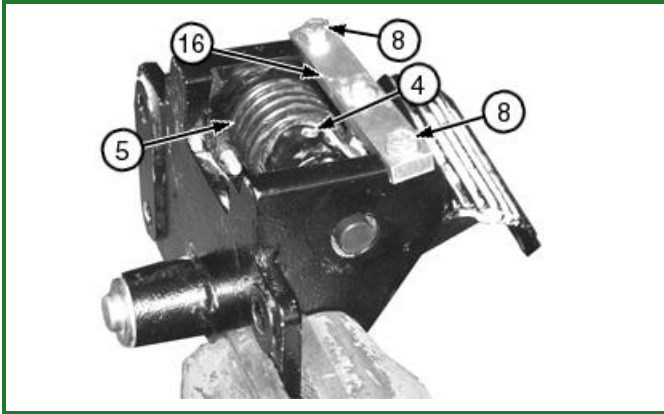
**T200194A-UN: Remove Stop Plate****LEGEND:**

4 - Pin

5 - Torsion Spring

8 - Cap Screw (2 used)

16 - Stop Plate

Loosen cap screws (8) securing stop plate (16).

5. Remove cap screws (8), relieving tension in torsion spring (5).

6.

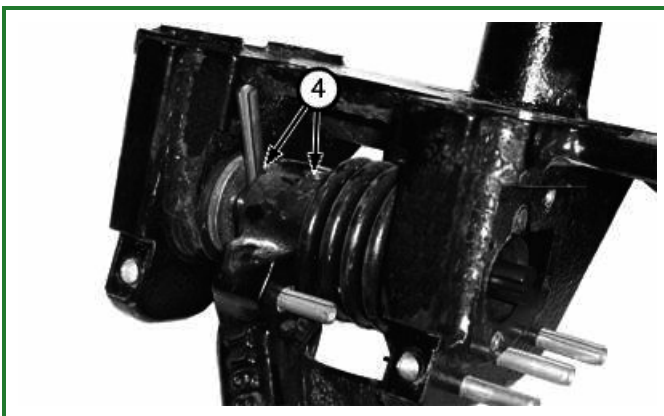
**T200195A-UN: Remove pins****LEGEND:**

4 - Pin (2 used)

Remove pins (4) retaining pedal on shaft.

7.

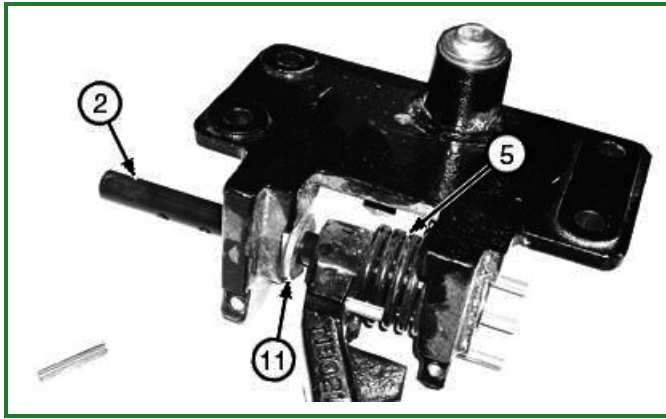
**T200196A-UN: Remove Shaft****LEGEND:**

2 - Shaft

5 - Torsion Spring

11 - Washer

Remove shaft (2).

8.

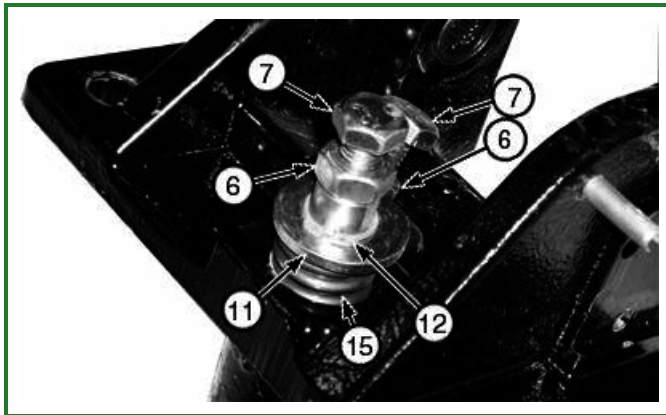
**T200197A-UN: Remove Stop Cap Screws****LEGEND:**

6 - Retaining Nut (2 used)

7 - Cap Screw (2 used)

11 - Washer

12 - Snap Ring

15 - Spring

Loosen retaining nuts (6).

9. Remove cap screws (7).

10. Apply pressure to washer (11) to compress spring (15) enough to remove snap ring (12).

11.

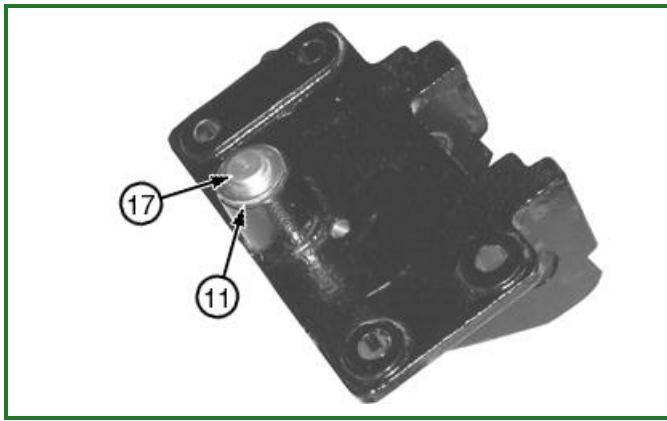
**T200198A-UN: Remove Pin****LEGEND:**

11 - Washer

17 - Pin Fastener

Remove pin fastener (17) and washer (11).

12. Disassemble remaining parts as necessary. Press out roller bearings (13) if necessary.

13.

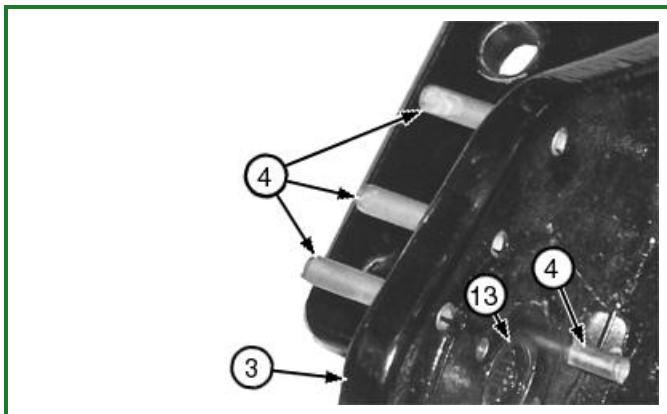
**T200199A-UN: Install Pins and Bearings****LEGEND:**

3 - Support

4 - Pin (4 used)

13 - Roller Bearing (2 used)

Press bearings (13) into support (3) to specification.

Item	Measurement	Specification
Bearing Placement	Distance from inside surface	0.0—1.0 mm 0.0—0.039 in.

14. Apply petroleum jelly to bearing rollers.

15. Install pins (4) into support (3) to specification.

Item	Measurement	Specification
Pin Placement	Distance from surface	0.0—1.0 mm 0.0—0.039 in.

16. Install pin fastener (17) through washer (11) into back of support (3).

17.

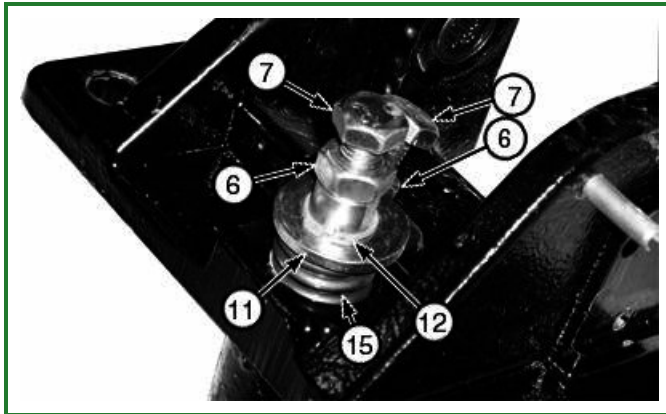
**T200197A-UN: Assemble Brake Stop****LEGEND:**

- 6 - Retaining Nut (2 used)
- 7 - Cap Screw (2 used)
- 11 - Washer
- 12 - Snap Ring
- 15 - Spring

Install spring (15) and washer (11) onto shaft and compress to install snap ring (12).

18. Install retaining nuts (6) onto cap screws (7). Install cap screws. Tighten nuts to specification.

Item	Measurement	Specification
Retaining Nuts	Torque	73 N·m 54 lb-ft

19.

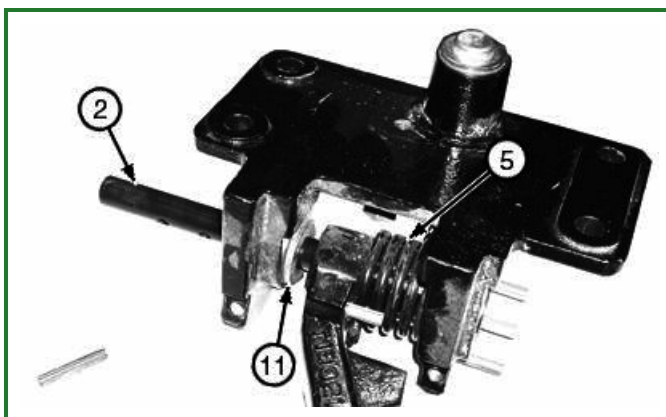
**T200196A-UN: Assemble Shaft and Pedal****LEGEND:**

- 2 - Shaft
- 5 - Torsion Spring
- 11 - Washer

Assemble torsion spring (5) onto pedal then rotate spring until spring is stopped by pin.

20. Place pedal with spring and washer (11) into support and install shaft (2) through assembly.

21.

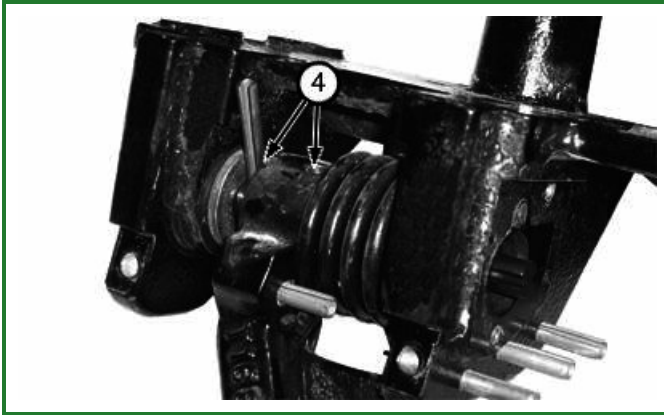

T200195A-UN: Remove pins

LEGEND:

4 - Pin (2 used)

Verify torsion spring is installed correctly then install pin (4) into the outer hole on shaft, between washer and pedal. Verify pin has equal length on each side of shaft.

22. Rotate pedal to align the hole in the pedal and shaft. Install pin (4) into hole.

23.

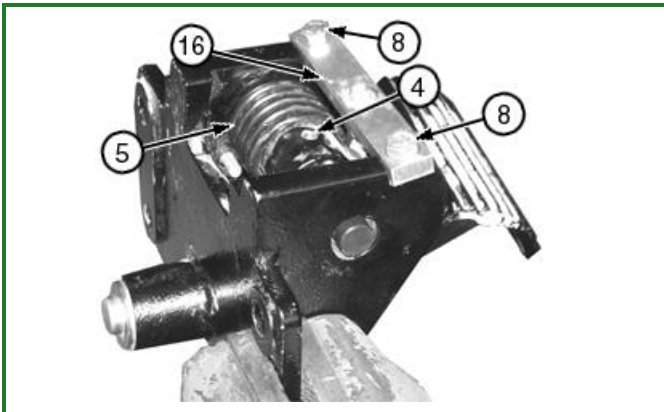

T200194A-UN: Install Stop Plate

LEGEND:

4 - Pin

5 - Torsion Spring

8 - Cap Screw (2 used)

16 - Stop Plate

Secure pedal assembly and press pedal downwards. Install stop plate (16) and secure with cap screws (8). Tighten cap screws to specification.

Item	Measurement	Specification
Stop Plate Cap Screws	Torque	37 N·m 27 lb-ft

24. Install decelerator sensor (14) with O-ring (18) onto shaft.

25. Slowly rotate sensor into position and install hex socket head cap screws (9). Tighten to specifications.

Item	Measurement	Specification
Sensor Hex Socket Head Cap Screws	Torque	6.1 N·m 4.5 lb-ft

26. Install assembly on machine. See [Decelerator/Brake Pedal Remove and Install](#) . (Group 0515.)
27. [Perform Decelerator/Brake Pedal Adjustment](#) . (Group 9015-20.)

Go to [Section_05:Group_0515](#)

MF82180,00001DB-19-20050714

Air Cleaner Remove and Install 550J and 650J

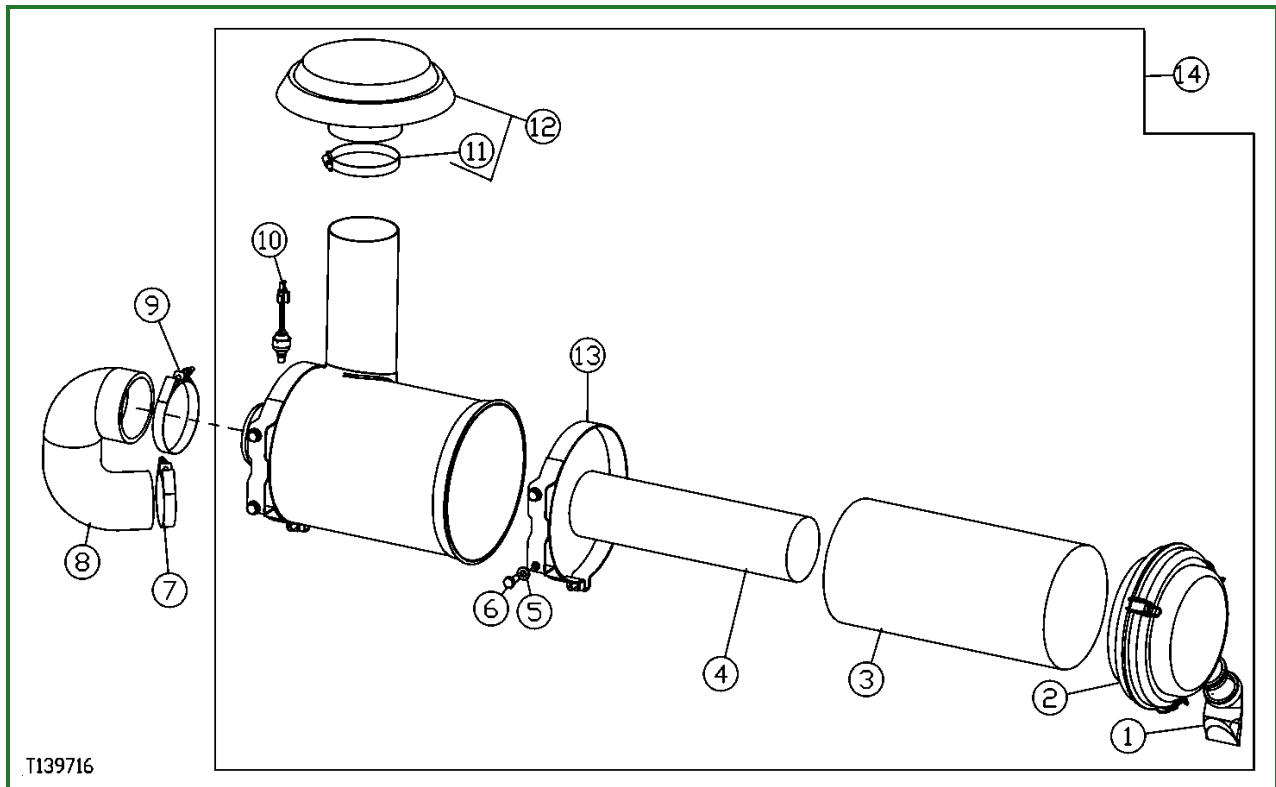
**T139716-UN: Air Cleaner****LEGEND:**

- 1 - Valve
- 2 - Cover
- 3 - Primary Element
- 4 - Secondary Element
- 5 - Washer (4 used)
- 6 - Cap Screw (4 used)
- 7 - Hose Clamp
- 8 - Hose
- 9 - Hose Clamp
- 10 - Air Filter Restriction Sensor
- 11 - Clamp
- 12 - Cap
- 13 - Band
- 14 - Air Cleaner

1. Remove precleaner and hood.
2. Remove and install parts as needed.
3. Inspect elements for wear or damage and replace as necessary.
4. Install parts.
5. Tighten all clamps and band cap screws (9).
6. Install hood and precleaner. [See Hood Remove and Install](#) . (Group 1910.)

Go to [Section_05:Group_0520](#)

TX03399,00018DB-19-20010307

Air Cleaner Remove and Install 550J and 650J

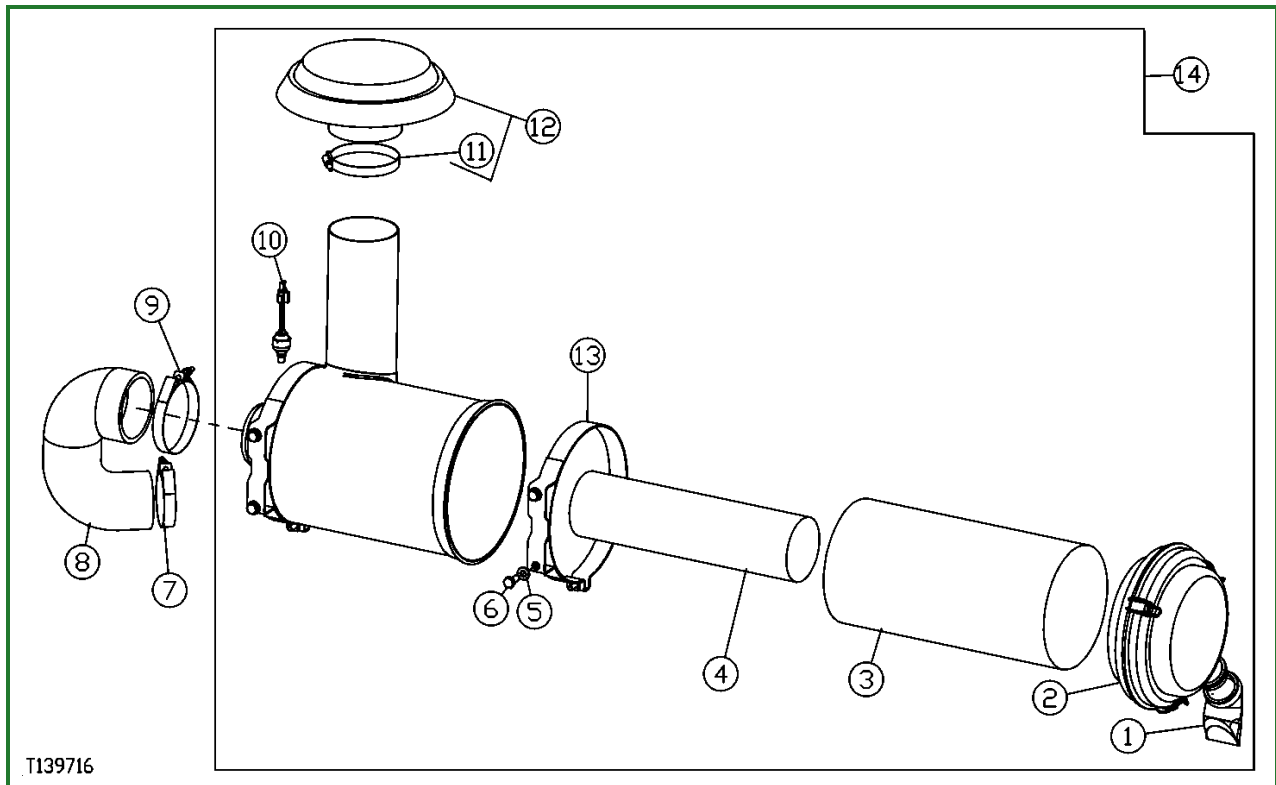
**T139716-UN: Air Cleaner****LEGEND:**

- 1 - Valve
- 2 - Cover
- 3 - Primary Element
- 4 - Secondary Element
- 5 - Washer (4 used)
- 6 - Cap Screw (4 used)
- 7 - Hose Clamp
- 8 - Hose
- 9 - Hose Clamp
- 10 - Air Filter Restriction Sensor
- 11 - Clamp
- 12 - Cap
- 13 - Band
- 14 - Air Cleaner

1. Remove precleaner and hood.
2. Remove and install parts as needed.
3. Inspect elements for wear or damage and replace as necessary.
4. Install parts.
5. Tighten all clamps and band cap screws (9).
6. Install hood and precleaner. [See Hood Remove and Install](#) . (Group 1910.)

Go to [Section_05:Group_0520](#)

TX03399,00018DB-19-20010307

Muffler Without Turbocharger Remove and Install

1.

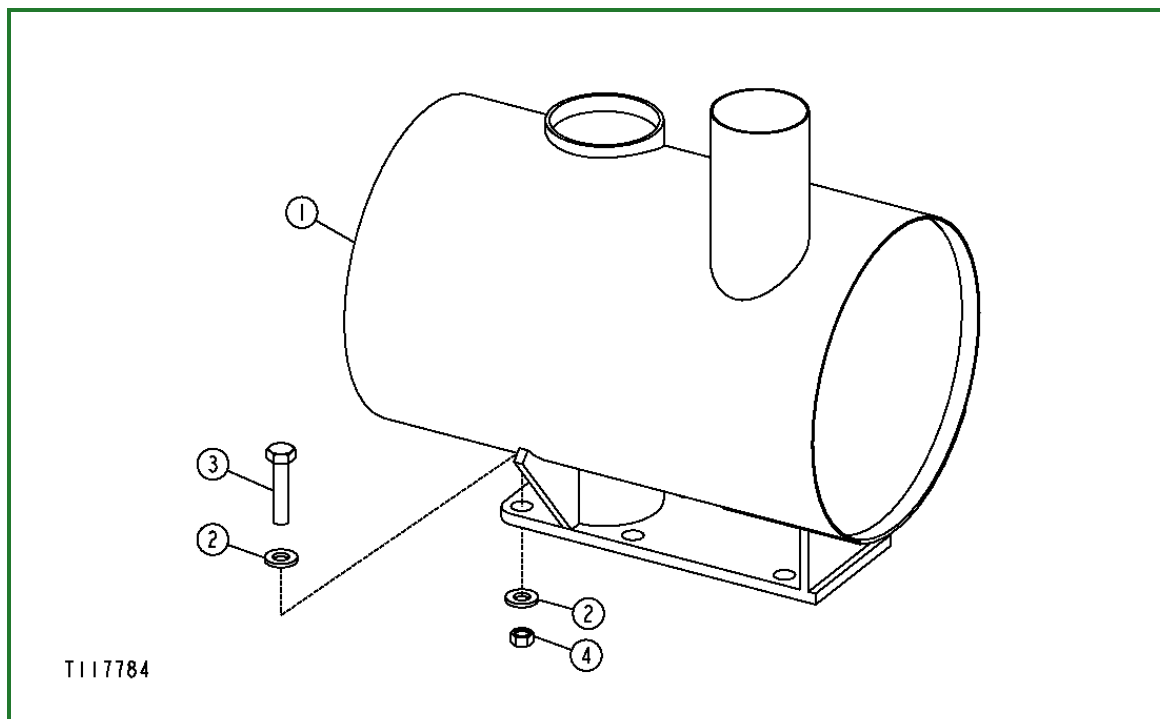

T117784-UN: Muffler Without Turbocharger

LEGEND:

- 1 - Muffler
- 2 - Washer (12 used)
- 3 - Cap Screw (6 used)
- 4 - Nut (6 used)

Remove engine side shields and hood. [See Hood Remove and Install](#) . (Group 1910.)

2. Remove muffler.
3. Install muffler and tighten cap screws.

Item	Measurement	Specification
Muffler w/o Turbocharger		
Muffler-to-Exhaust Manifold Torque		73 N·m 54 lb-ft

Go to [Section_05:Group_0530](#)

CED,TX03399,5041-19-20040309

Muffler Without Turbocharger Remove and Install

1.

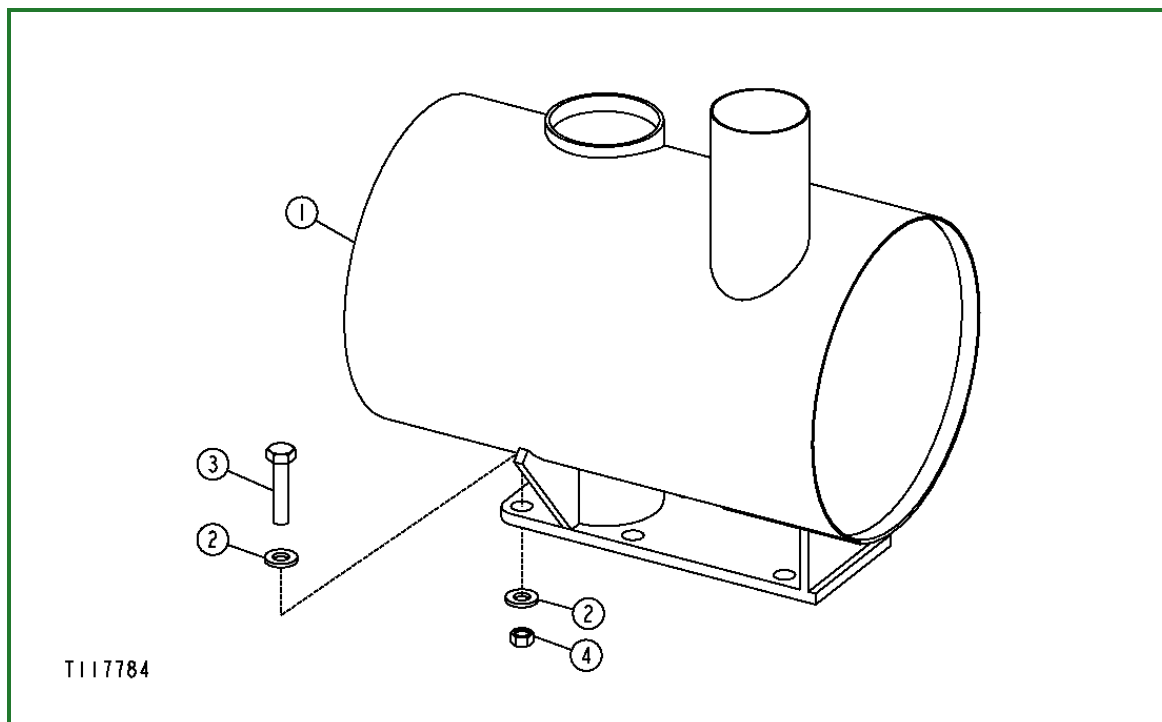

T117784-UN: Muffler Without Turbocharger

LEGEND:

- 1 - Muffler
- 2 - Washer (12 used)
- 3 - Cap Screw (6 used)
- 4 - Nut (6 used)

Remove engine side shields and hood. [See Hood Remove and Install](#) . (Group 1910.)

2. Remove muffler.
3. Install muffler and tighten cap screws.

Item	Measurement	Specification
Muffler w/o Turbocharger		
Muffler-to-Exhaust Manifold Torque		73 N·m 54 lb-ft

Go to [Section_05:Group_0530](#)

CED,TX03399,5041-19-20040309

Muffler With Turbocharger Remove and Install

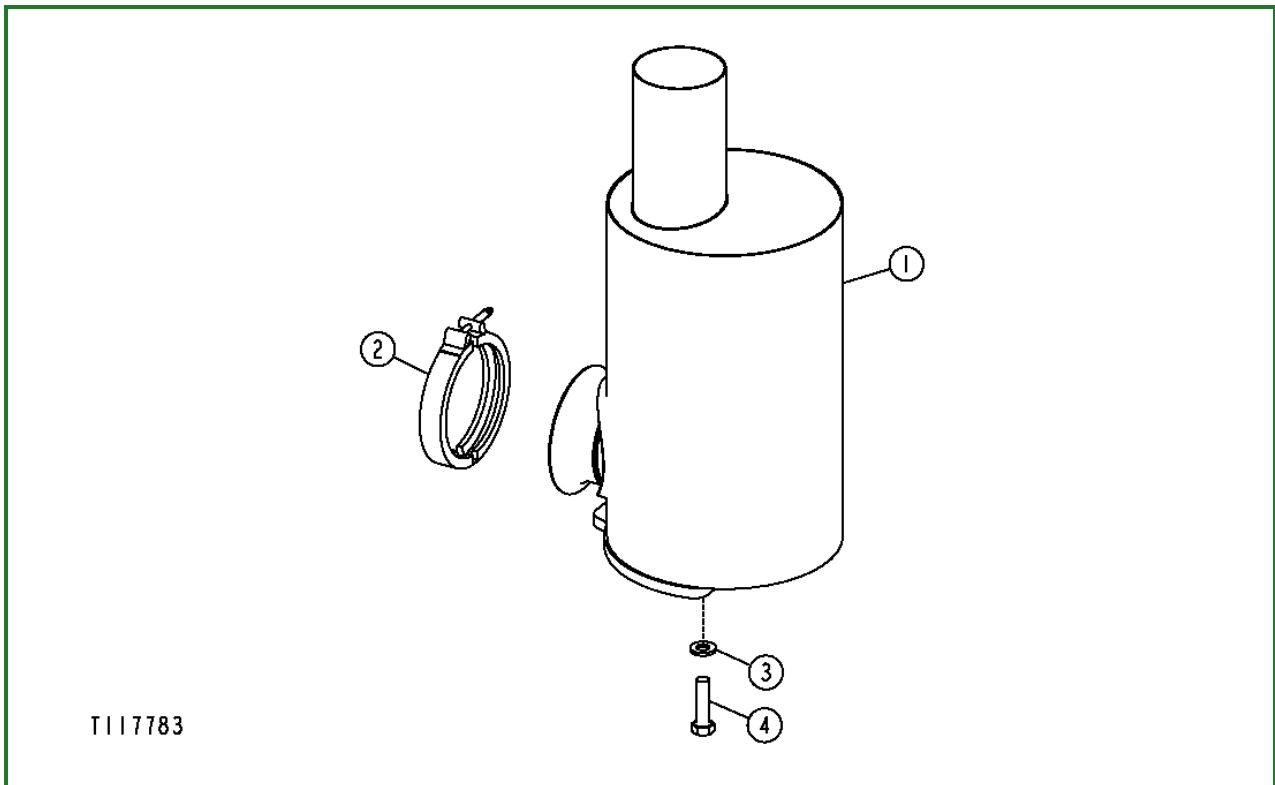

T117783-UN: Muffler With Turbocharger

LEGEND:

- 1 - Muffler
- 2 - Clamp
- 3 - Washer (3 used)
- 4 - Cap Screw (3 used)

1. Remove engine side shields and hood. [See Hood Remove and Install](#) . (Group 1910.)
2. Remove muffler.
3. Install muffler and tighten cap screws.

Item	Measurement	Specification
Muffler with Turbocharger		
Muffler-to-Exhaust Manifold Torque		73 N·m 54 lb-ft

Go to [Section_05:Group_0530](#)

CED, TX03399, 5043-19-20040309

Engine and Power Train Mounting

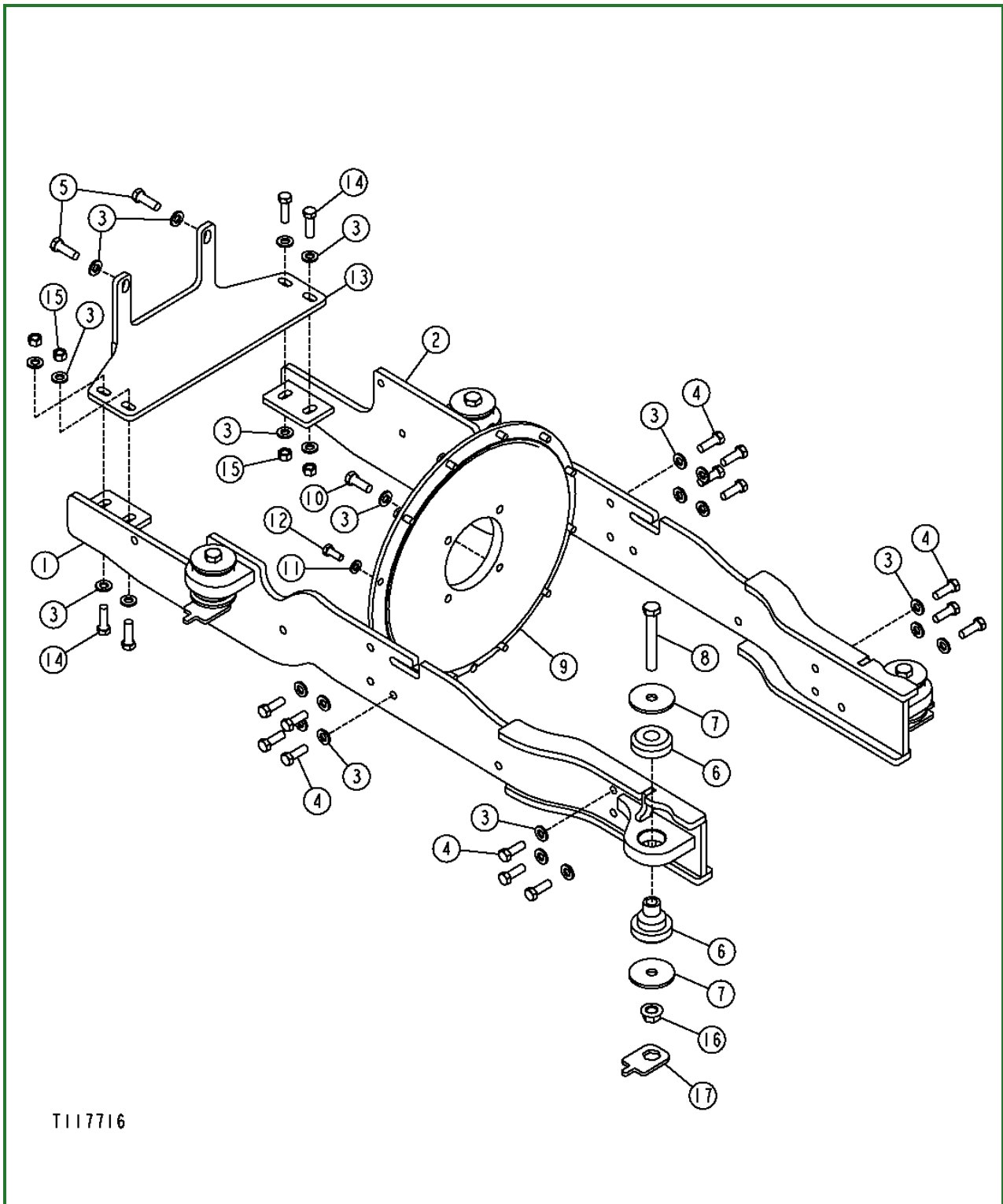

T117716-UN: Engine and Power Train Mounting Frames

LEGEND:

- 1 - Right Hand Side Rail Frame
- 2 - Left Hand Side Rail Frame
- 3 - Washer (28 used)
- 4 - Front and Rear Side Rails-to-Engine Cap Screw (14 used)
- 5 - Rear Support Bracket-to-Rear Hydraulic Pump Cap Screw (2 used)
- 6 - Rubber Mount (4 used)
- 7 - Washer (8 used)
- 8 - Side Rails-to-Main Frame Cap Screw (4 used)

- 9 - Cover
- 10 - Pump-to-Flywheel Cover Cap Screw (4 used)
- 11 - Washer (12 used)
- 12 - Flywheel Cover-to-Engine Flywheel Cap Screw (12 used)
- 13 - Bracket
- 14 - Rear Pump Support-to-Side Rail Cap Screw (4 used)
- 15 - Nut (4 used)
- 16 - Nut (4 used)
- 17 - Locking Plate (4 used)

Item	Measurement	Specification
Engine and Power Train Mounting Parts		
Side Rails-to-Engine Cap Screws	Torque	130 N·m 96 lb-ft
Pump-to-Flywheel Cover Cap Screws	Torque	140 N·m 103 lb-ft
Flywheel Cover to Engine Flywheel Cap Screws	Torque	73 N·m 54 lb-ft
Rear Pump Support Bracket-to-Side Rails Cap Screws	Torque	140 N·m 103 lb-ft
Rear Support Bracket-to-Rear Hydrostatic Pump Cap Screws	Torque	140 N·m 103 lb-ft
Side Rails to Main Frame Cap Screws	Torque	320 N·m 236 lb-ft

Go to [Section_05:Group_0540](#)

CED, TX03399, 5021-19-19990413

Engine and Power Train Mounting

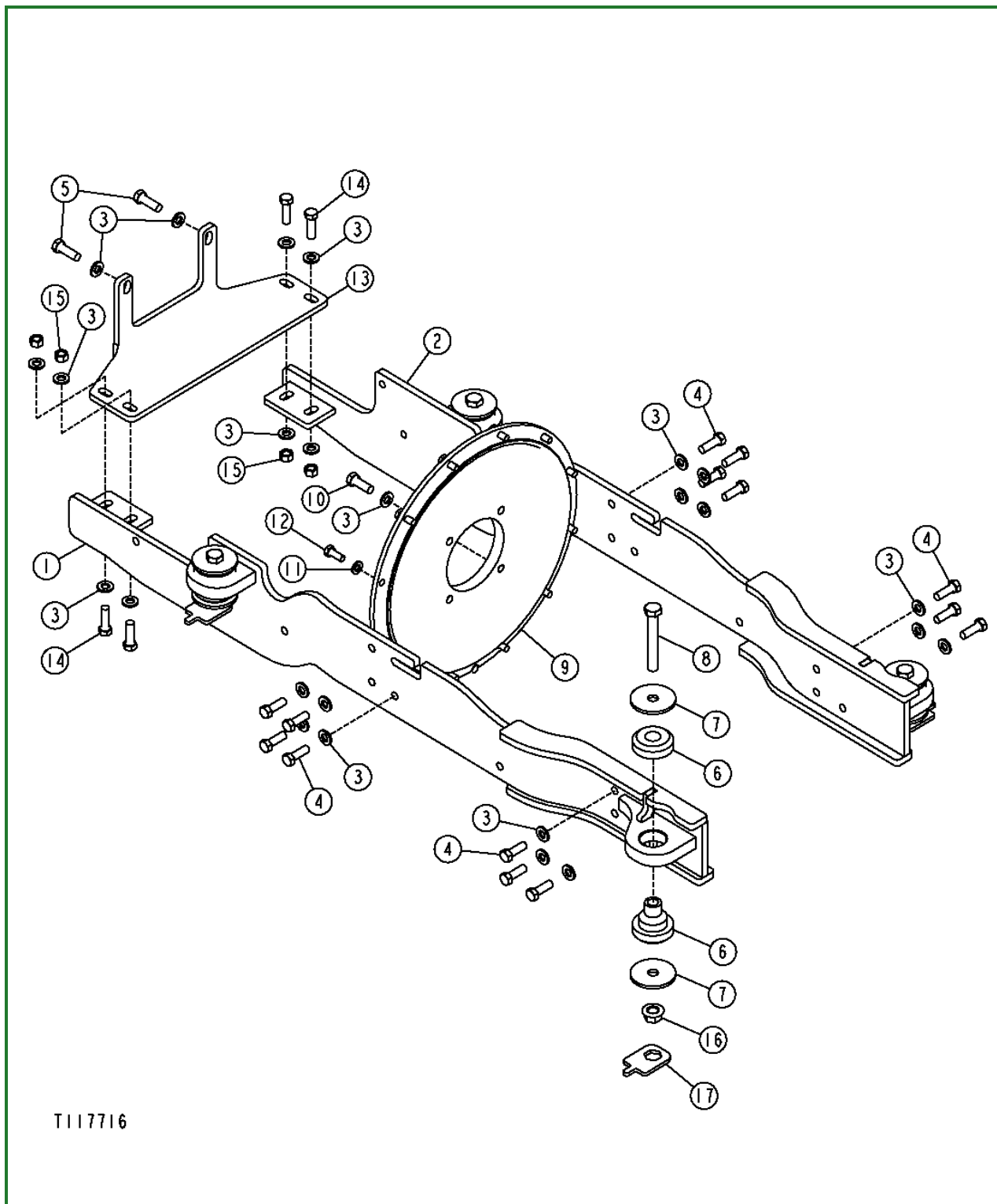

T117716

T117716-UN: Engine and Power Train Mounting Frames

LEGEND:

- 1 - Right Hand Side Rail Frame
- 2 - Left Hand Side Rail Frame
- 3 - Washer (28 used)
- 4 - Front and Rear Side Rails-to-Engine Cap Screw (14 used)
- 5 - Rear Support Bracket-to-Rear Hydraulic Pump Cap Screw (2 used)
- 6 - Rubber Mount (4 used)
- 7 - Washer (8 used)
- 8 - Side Rails-to-Main Frame Cap Screw (4 used)

- 9 - Cover
- 10 - Pump-to-Flywheel Cover Cap Screw (4 used)
- 11 - Washer (12 used)
- 12 - Flywheel Cover-to-Engine Flywheel Cap Screw (12 used)
- 13 - Bracket
- 14 - Rear Pump Support-to-Side Rail Cap Screw (4 used)
- 15 - Nut (4 used)
- 16 - Nut (4 used)
- 17 - Locking Plate (4 used)

Item	Measurement	Specification
Engine and Power Train Mounting Parts		
Side Rails-to-Engine Cap Screws	Torque	130 N·m 96 lb-ft
Pump-to-Flywheel Cover Cap Screws	Torque	140 N·m 103 lb-ft
Flywheel Cover to Engine Flywheel Cap Screws	Torque	73 N·m 54 lb-ft
Rear Pump Support Bracket-to-Side Rails Cap Screws	Torque	140 N·m 103 lb-ft
Rear Support Bracket-to-Rear Hydrostatic Pump Cap Screws	Torque	140 N·m 103 lb-ft
Side Rails to Main Frame Cap Screws	Torque	320 N·m 236 lb-ft

Go to [Section_05:Group_0540](#)

CED, TX03399, 5021-19-19990413

Fuel Tank Remove and Install

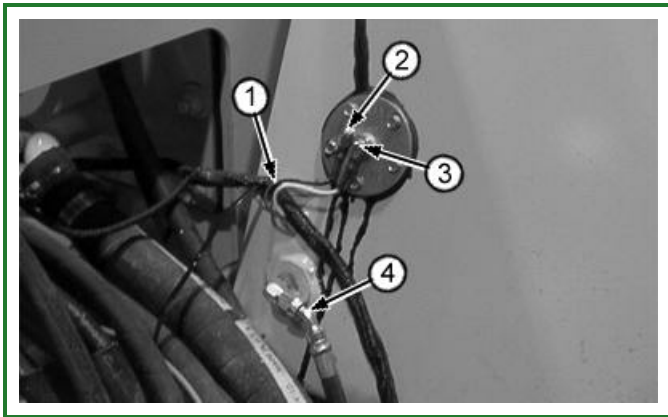

T117744B-UN: Fuel Tank Sender

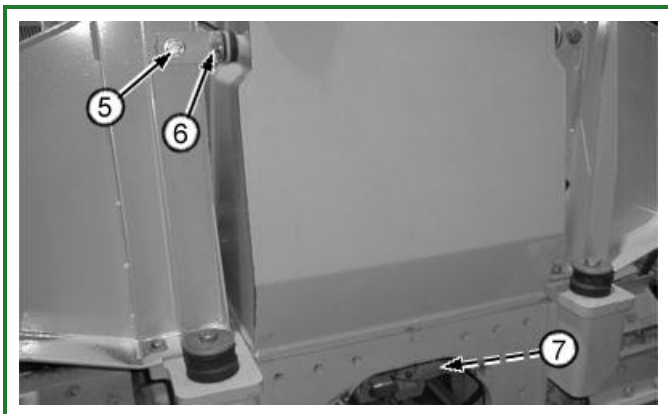

T117888B-UN: Fuel Tank Cap Screws

LEGEND:

- 1 - Tie Band
- 2 - Black Wire Lead
- 3 - Yellow Wire Lead
- 4 - Fuel Return Hose
- 5 - Bracket-to-Hydraulic/Hydrostatic Reservoir Cap Screw (2 used)
- 6 - Bracket-to-Isolator to Fuel Tank Cap Screw (2 used)
- 7 - Main Frame-to-Fuel Tank Cap Screw (4 used)

1. Remove cab or ROPS. [See Cab or ROPS Remove and Install](#) . (Group 1800.)
2. Remove rear access cover.
3. Drain fuel tank and disconnect fuel supply line, located by the fuel shut-off drain cock.

Item	Measurement	Specification
Fuel Tank Capacity	178 L 47 gal	

4. Cut tie band (1) and disconnect components (2—4).
5. Loosen cap screw (5) on both sides. Remove cap screws (6) and install lifting brackets.
6. Inspect fuel screen connected to the fuel shut-off valve.

7.

⚠ CAUTION:

Prevent possible crushing injury from removing fuel tank. Use proper lifting equipment and safety precautions.

Item	Measurement	Specification
Fuel Tank		
450J Fuel Tank	Weight	68 kg 150 lb
550J and 650J Fuel Tank	Weight	86 kg 190 gal

Attach chain and hoist to fuel tank.

8. Remove four cap screws (7) on bottom of fuel tank.

9. Install fuel tank. Tighten cap screws to specification.

Item	Measurement	Specification
Fuel Tank		
Main Frame-to-Fuel Tank Cap Screws	Torque	319 N·m 235 lb-ft
Fuel Tank Brackets to Hydrostatic/Hydraulic Reservoirs	Torque	244 N·m 180 lb-ft
Brackets-to-Isolators-to-Fuel Tank Cap Screws	Torque	87 N·m 64 lb-ft

10. Connect components (2—4) and fuel supply line. Install new tie band (1).

Item	Measurement	Specification
Fuel Tank		
Fuel Sender Float Cap Screws	Torque	10 N·m 90 lb-in.

11. Fill fuel tank with proper amount of correct fuel.

Item	Measurement	Specification
Fuel Tank		
Fuel Tank Capacity		178 L 47 gal

Go to [Section_05:Group_0560](#)

CED, TX03399, 5026-19-19990318

Fuel Tank Remove and Install

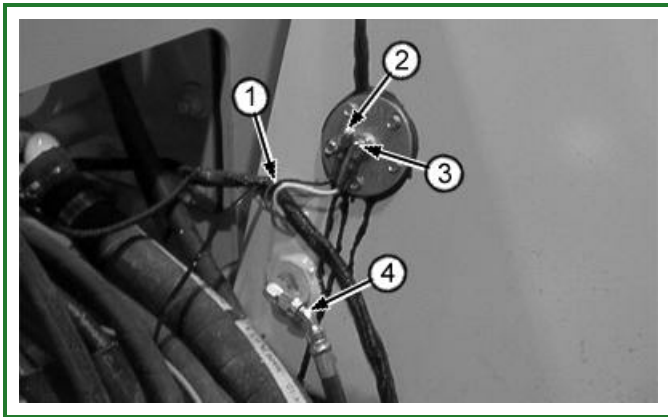

T117744B-UN: Fuel Tank Sender

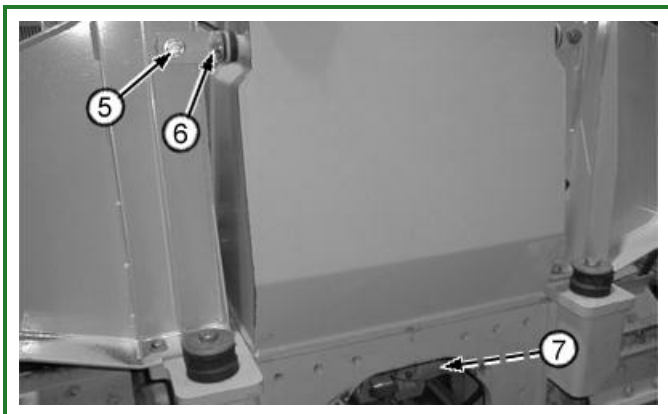

T117888B-UN: Fuel Tank Cap Screws

LEGEND:

- 1 - Tie Band
- 2 - Black Wire Lead
- 3 - Yellow Wire Lead
- 4 - Fuel Return Hose
- 5 - Bracket-to-Hydraulic/Hydrostatic Reservoir Cap Screw (2 used)
- 6 - Bracket-to-Isolator to Fuel Tank Cap Screw (2 used)
- 7 - Main Frame-to-Fuel Tank Cap Screw (4 used)

1. Remove cab or ROPS. [See Cab or ROPS Remove and Install](#) . (Group 1800.)
2. Remove rear access cover.
3. Drain fuel tank and disconnect fuel supply line, located by the fuel shut-off drain cock.

Item	Measurement	Specification
Fuel Tank Capacity	178 L 47 gal	

4. Cut tie band (1) and disconnect components (2—4).
5. Loosen cap screw (5) on both sides. Remove cap screws (6) and install lifting brackets.
6. Inspect fuel screen connected to the fuel shut-off valve.

7.

⚠ CAUTION:

Prevent possible crushing injury from removing fuel tank. Use proper lifting equipment and safety precautions.

Item	Measurement	Specification
Fuel Tank		
450J Fuel Tank	Weight	68 kg 150 lb
550J and 650J Fuel Tank	Weight	86 kg 190 gal

Attach chain and hoist to fuel tank.

8. Remove four cap screws (7) on bottom of fuel tank.

9. Install fuel tank. Tighten cap screws to specification.

Item	Measurement	Specification
Fuel Tank		
Main Frame-to-Fuel Tank Cap Screws	Torque	319 N·m 235 lb-ft
Fuel Tank Brackets to Hydrostatic/Hydraulic Reservoirs	Torque	244 N·m 180 lb-ft
Brackets-to-Isolators-to-Fuel Tank Cap Screws	Torque	87 N·m 64 lb-ft

10. Connect components (2—4) and fuel supply line. Install new tie band (1).

Item	Measurement	Specification
Fuel Tank		
Fuel Sender Float Cap Screws	Torque	10 N·m 90 lb-in.

11. Fill fuel tank with proper amount of correct fuel.

Item	Measurement	Specification
Fuel Tank		
Fuel Tank Capacity		178 L 47 gal

Go to [Section_05:Group_0560](#)

CED, TX03399, 5026-19-19990318

Section 07: Dampener Drive

Group 0752: Elements

Dampener Drive Remove and Install

Dampener Drive Remove and Install

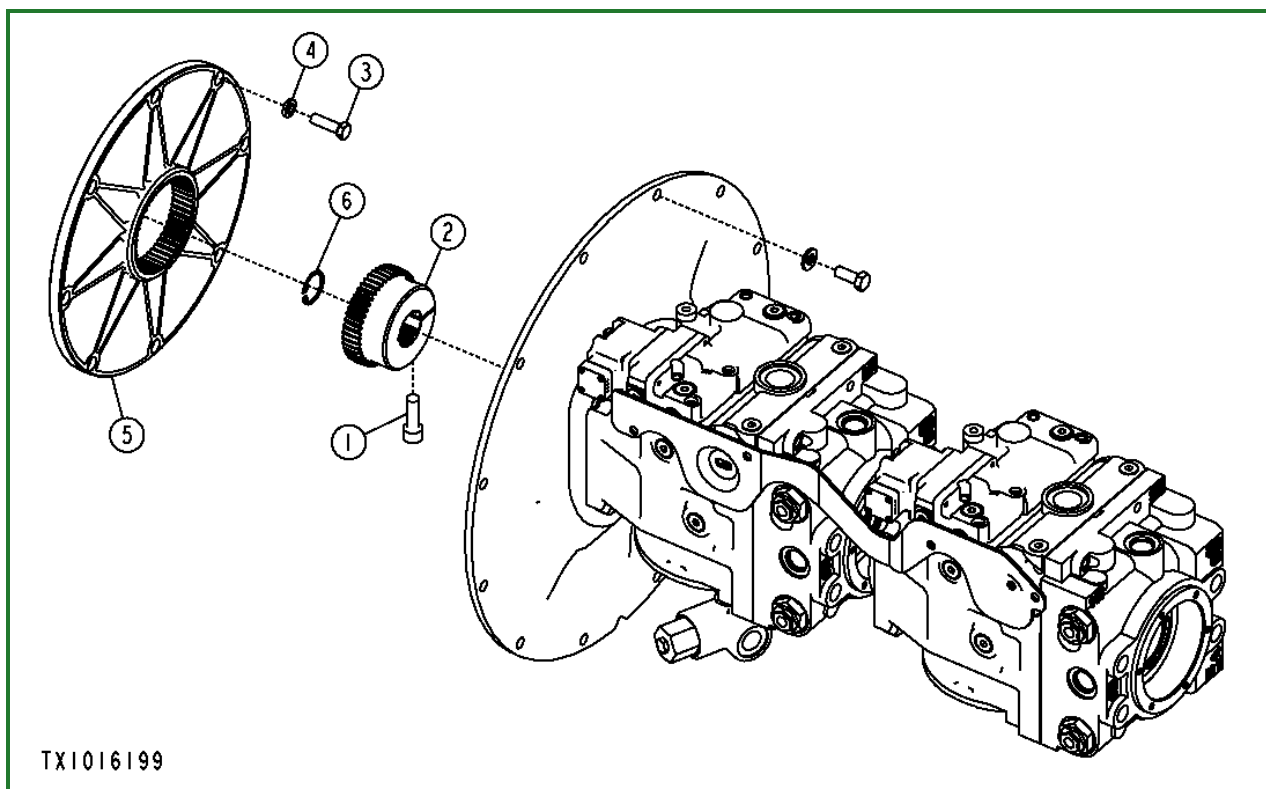

TX1016199-UN: Dampener Components

LEGEND:

- 1 - Set Screw M12 x 35
- 2 - Dampener Hub
- 3 - Cap Screw (8 used)
- 4 - Washer (8 used)
- 5 - Dampener Plate
- 6 - Snap Ring

1. Remove hydrostatic pumps. See [Hydrostatic Pump Remove and Install](#) . (Group 0300.)
2. Remove set screw (1) from dampener hub (2).
3. Remove dampener hub. If necessary, use a puller to remove.
4. Remove cap screws (3) and dampener (5) from flywheel.
5. Install snap ring (6), in internal spline groove, of dampener hub.
6. Install new dampener hub (2) until pump shaft contacts snap ring.
7. Install set screws (1) and tighten to specification.

Item	Measurement	Specification
Dampener Drive		
Dampener Hub-to-Hydrostatic Pump Shaft Set Screw	Torque	86 N·m 63 lb-ft

8. Use clean and cure primer to prepare cap screw threads and allow two minutes to cure. Apply thread

lock and sealer (medium strength) to threads of cap screws (3).

9. Install new dampener plate (5) with the internal gear teeth largest offset side away from flywheel. Install cap screws (3) and washers (4) and tighten cap screws to specifications.

Item	Measurement	Specification
Dampener Drive		
Dampener-to-Flywheel Cap Screws	Torque	57 N·m 42 lb-ft

10. Install hydrostatic pumps. [See Hydrostatic Pump Remove and Install .](#) (Group 0300.)

Go to [Section_07:Group_0752](#)

TX,0752,SS2306-19-20061206

Dampener Drive Remove and Install

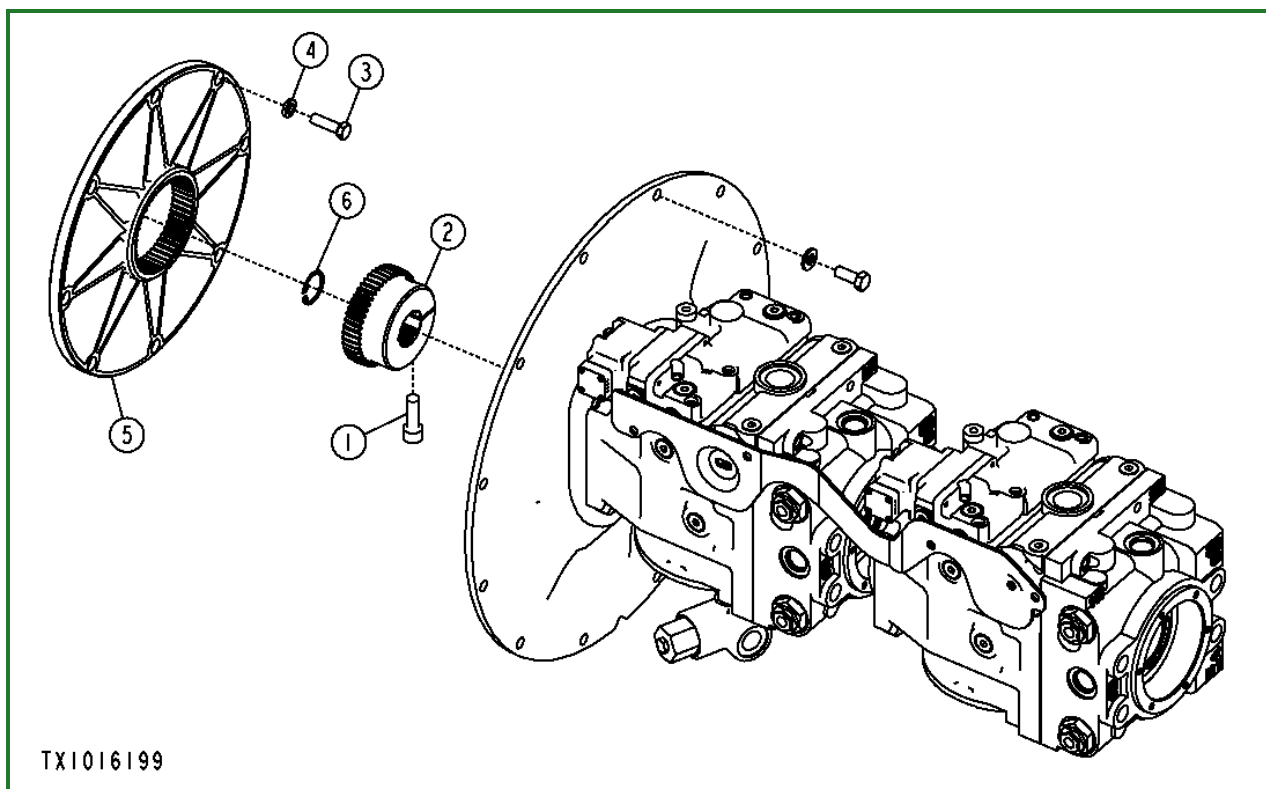

TX1016199-UN: Dampener Components

LEGEND:

- 1 - Set Screw M12 x 35
- 2 - Dampener Hub
- 3 - Cap Screw (8 used)
- 4 - Washer (8 used)
- 5 - Dampener Plate
- 6 - Snap Ring

1. Remove hydrostatic pumps. [See Hydrostatic Pump Remove and Install](#) . (Group 0300.)
2. Remove set screw (1) from dampener hub (2).
3. Remove dampener hub. If necessary, use a puller to remove.
4. Remove cap screws (3) and dampener (5) from flywheel.
5. Install snap ring (6), in internal spline groove, of dampener hub.
6. Install new dampener hub (2) until pump shaft contacts snap ring.
7. Install set screws (1) and tighten to specification.

Item	Measurement	Specification
Dampener Drive		
Dampener Hub-to-Hydrostatic Pump Shaft Set Screw	Torque	86 N·m 63 lb-ft

8. Use clean and cure primer to prepare cap screw threads and allow two minutes to cure. Apply thread

lock and sealer (medium strength) to threads of cap screws (3).

9. Install new dampener plate (5) with the internal gear teeth largest offset side away from flywheel. Install cap screws (3) and washers (4) and tighten cap screws to specifications.

Item	Measurement	Specification
Dampener Drive		
Dampener-to-Flywheel Cap Screws	Torque	57 N·m 42 lb-ft

10. Install hydrostatic pumps. [See Hydrostatic Pump Remove and Install](#) . (Group 0300.)

Go to [Section_07:Group_0752](#)

TX,0752,SS2306-19-20061206

Section 11: Park Brake

Group 1100: Removal and Installation

Park Brake Valve Remove and Install

Park Brake Remove and Install

Group 1115: Control Linkage

Park Lock Linkage Remove and Install

Park Lock Linkage Disassemble and Assemble

Group 1160: Hydraulic System

Park Brake Valve Disassemble and Assemble

Park Brake Disassemble and Assemble

Park Brake Valve Remove and Install

1. Lower all equipment to ground and stop engine.
2. Place park lock lever in UP (locked) position.
3. Turn battery disconnect switch OFF.

4.

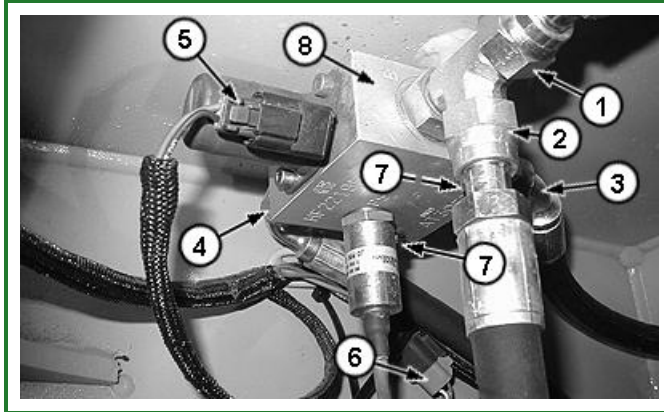

T199511A-UN: Park Brake Valve

LEGEND:

- 1 - Hose (valve to right park brake)
- 2 - Hose (valve to left park brake)
- 3 - Hose (valve to hydrostatic reservoir)
- 4 - Hose (from charge pump)
- 5 - Connector (solenoid to harness)
- 6 - Connector (transmission oil pressure sensor to harness)
- 7 - Cap Screw (2 used)
- 8 - Park Brake Valve

Disconnect hoses (1—4).

5. Disconnect harness connectors (5 and 6).
6. Remove cap screws (7) and park brake valve (8).
7. Install park brake valve (8) and tighten cap screws (7) to specification.

Item	Measurement	Specification
Park Brake Valve Mounting Cap Screws	Torque	37 N·m 27 lb.-ft.

8. Connect harness connectors (5 and 6).
9. Connect hoses (1—4).
10. Turn battery disconnect switch to ON.

Park Brake Valve Remove and Install

1. Lower all equipment to ground and stop engine.
2. Place park lock lever in UP (locked) position.
3. Turn battery disconnect switch OFF.

4.

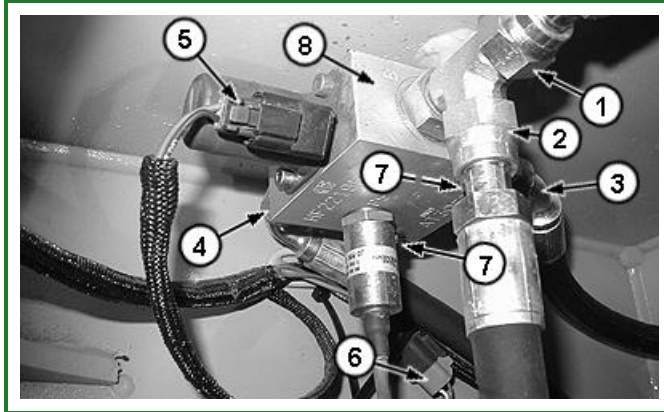

T199511A-UN: Park Brake Valve

LEGEND:

- 1 - Hose (valve to right park brake)
- 2 - Hose (valve to left park brake)
- 3 - Hose (valve to hydrostatic reservoir)
- 4 - Hose (from charge pump)
- 5 - Connector (solenoid to harness)
- 6 - Connector (transmission oil pressure sensor to harness)
- 7 - Cap Screw (2 used)
- 8 - Park Brake Valve

Disconnect hoses (1—4).

5. Disconnect harness connectors (5 and 6).
6. Remove cap screws (7) and park brake valve (8).
7. Install park brake valve (8) and tighten cap screws (7) to specification.

Item	Measurement	Specification
Park Brake Valve Mounting Cap Screws	Torque	37 N·m 27 lb.-ft.

8. Connect harness connectors (5 and 6).
9. Connect hoses (1—4).
10. Turn battery disconnect switch to ON.

Park Brake Remove and Install

1. Lower all equipment to the ground.
2. Stop engine. Operate all hydraulic controls to release pressure in the hydraulic system.
3. Turn battery disconnect switch to OFF.
4. Remove hydrostatic motor. [See Hydrostatic Motor Remove and Install](#) . (Group 0300.)

5.

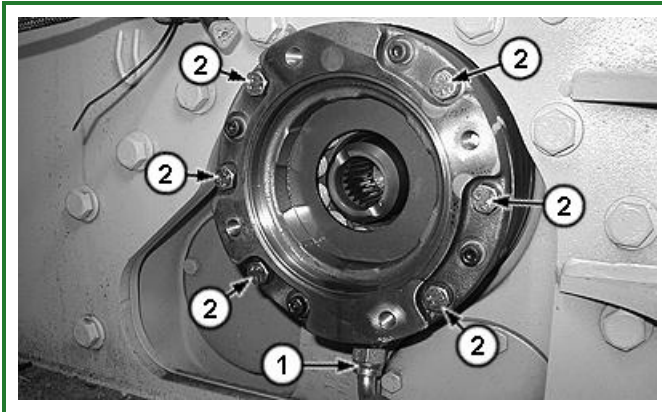

T199199A-UN: Park Brake Remove and Install

LEGEND:

- 1 - Park Brake Hose
- 2 - Cap Screw (6 used)

Disconnect park brake hose (1).

6. Remove cap screw (2).

7.

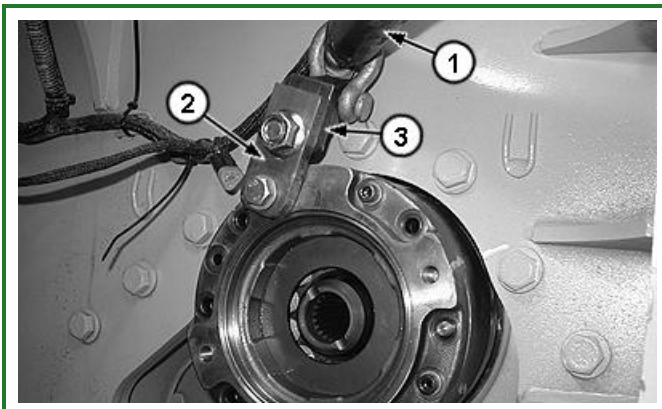

T199200A-UN: Dealer Fabricated Tools

LEGEND:

- 1 - DFT1132 Hydrostatic Motor Removal and Installation Tool
- 2 - DFT1211 Final Drive Lifting Bracket Adapter
- 3 - JT01748 Lifting Bracket

Attach DFT1132 Hydrostatic Motor and Hydraulic Pump Removal and Installation Tool (1) to hoist with sling. [See DFT1132 Hydrostatic Motor Removal and Installation Tool](#) . (Group 9900.)

Attach DFT1211 Final Drive Lifting Bracket Adapter (2) to JT01748 Lifting Bracket (3) with cap screw. See [DFT1211 Final Drive Lifting Bracket Adapter](#) . (Group 9900.)

Attach JT01748 Lifting Bracket and DFT1132 Hydrostatic Motor and Hydraulic Pump Removal and Installation Tool to park brake with cap screw.

8.

NOTE:

Make sure coupler from final drive to park brake remains fully engaged in final drive.

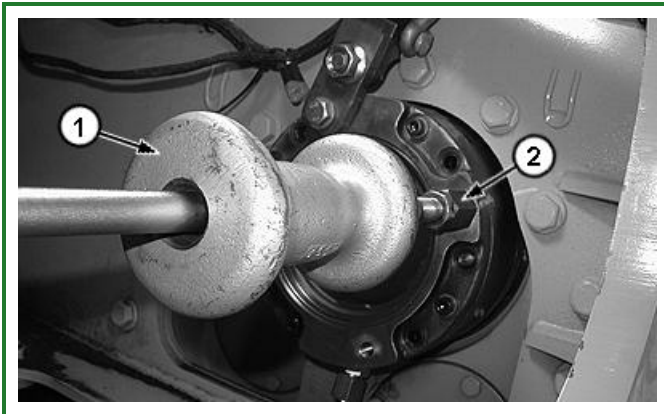

T199201A-UN: Slide Hammer

LEGEND:

1 - Slide Hammer

2 - Threaded Adapter

Install slide hammer in threaded hole using adapter. Pull park brake assembly using slide hammer while keeping coupler in final drive.

9. Remove through frame opening in rear of machine.

10.

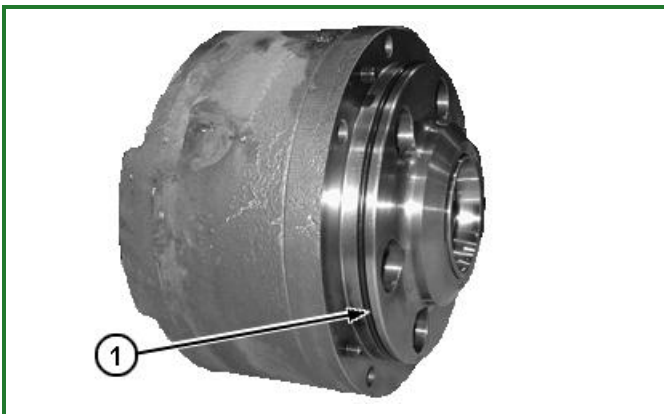

T199203A-UN: O-ring

LEGEND:

1 - O-ring

Remove O-ring (1) from park brake flange.

11. Repair or replace park brake

11. Repair or replace park brake.
12. Clean and inspect parts.
13. Apply petroleum jelly to new O-ring and install on park brake flange.

14.

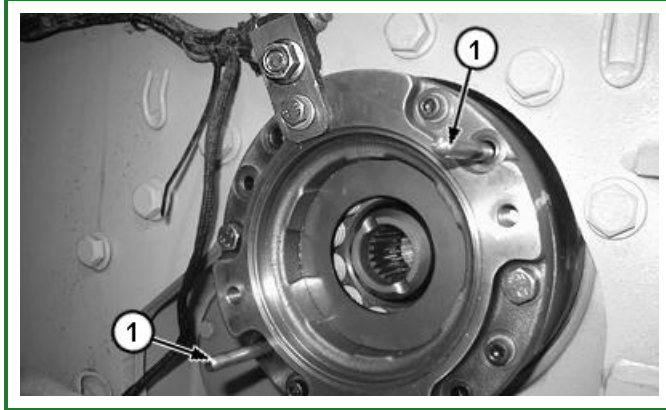

T199206A-UN: Guide Screws

Install guide screws (1) in final drive.

Guide park brake through frame opening and position on guide screws.

15.



T199205A-UN: Bottle Jack

Install park brake into final drive. If necessary, move track using bottle jack under track shoe to help align final drive coupler to park brake.

16. Install two capscrews to secure park brake to final drive. Remove guide screws and install remaining capscrews.

Tighten capscrews to specification.

Item	Measurement	Specification
Park Brake Mounting Cap Screws	Torque	73 N·m 54 lb ft

17. Install park brake hose.

18. Install hydrostatic motor. [See Hydrostatic Motor Remove and Install](#) . (Group 0300.)
19. Fill reservoir if drained. [See Transmission and Hydraulic Oil](#) . (Operators Manual.)
20. Install rear access plate or rear mounted optional equipment.
21. Replace bottom access plates if removed.
22. Turn battery disconnect switch to ON.

Go to [Section_11:Group_1100](#)

TE14778,0000024-19-20040427

Park Lock Linkage Remove and Install

1. Lower all equipment to ground and stop engine.
2. Turn battery disconnected switch to OFF.

3.



T199669A-UN: Park Lock Lever Switch

Cut tie band and disconnect park lock lever switch connector (16) from cab harness.

4. Remove control lever knob.

5.



T199668A-UN: Park Lock Lever (Mounting Cap Screws)

Remove two cap screws (8) from front of left side console.

6. Remove park lock lever assembly from left side console.
7. Assemble park lock lever assembly to left side console using two cap screws (8). Tighten to specification.

Item	Measurement	Specification
Park Lock Lever Mounting Cap Screw	Torque	73 N·m 54 lb-ft

8. Assemble control lever knob onto control lever. Tighten nut to specification.

Item	Measurement	Specification
Control Lever Knob Nut	Torque	23 N·m 17 lb-ft

9. Connect park lock lever switch connector (16) to cab harness.
10. Turn battery disconnected switch to ON.

Go to [Section_11:Group_1115](#)

TE14778,000002D-19-20040507

Park Lock Linkage Remove and Install

1. Lower all equipment to ground and stop engine.
2. Turn battery disconnected switch to OFF.

3.



T199669A-UN: Park Lock Lever Switch

Cut tie band and disconnect park lock lever switch connector (16) from cab harness.

4. Remove control lever knob.

5.



T199668A-UN: Park Lock Lever (Mounting Cap Screws)

Remove two cap screws (8) from front of left side console.

6. Remove park lock lever assembly from left side console.
7. Assemble park lock lever assembly to left side console using two cap screws (8). Tighten to specification.

Item	Measurement	Specification
Park Lock Lever Mounting Cap Screw	Torque	73 N·m 54 lb-ft

8. Assemble control lever knob onto control lever. Tighten nut to specification.

Item	Measurement	Specification
Control Lever Knob Nut	Torque	23 N·m 17 lb-ft

9. Connect park lock lever switch connector (16) to cab harness.
10. Turn battery disconnected switch to ON.

Go to [Section_11:Group_1115](#)

TE14778,000002D-19-20040507

Park Lock Linkage Disassemble and Assemble

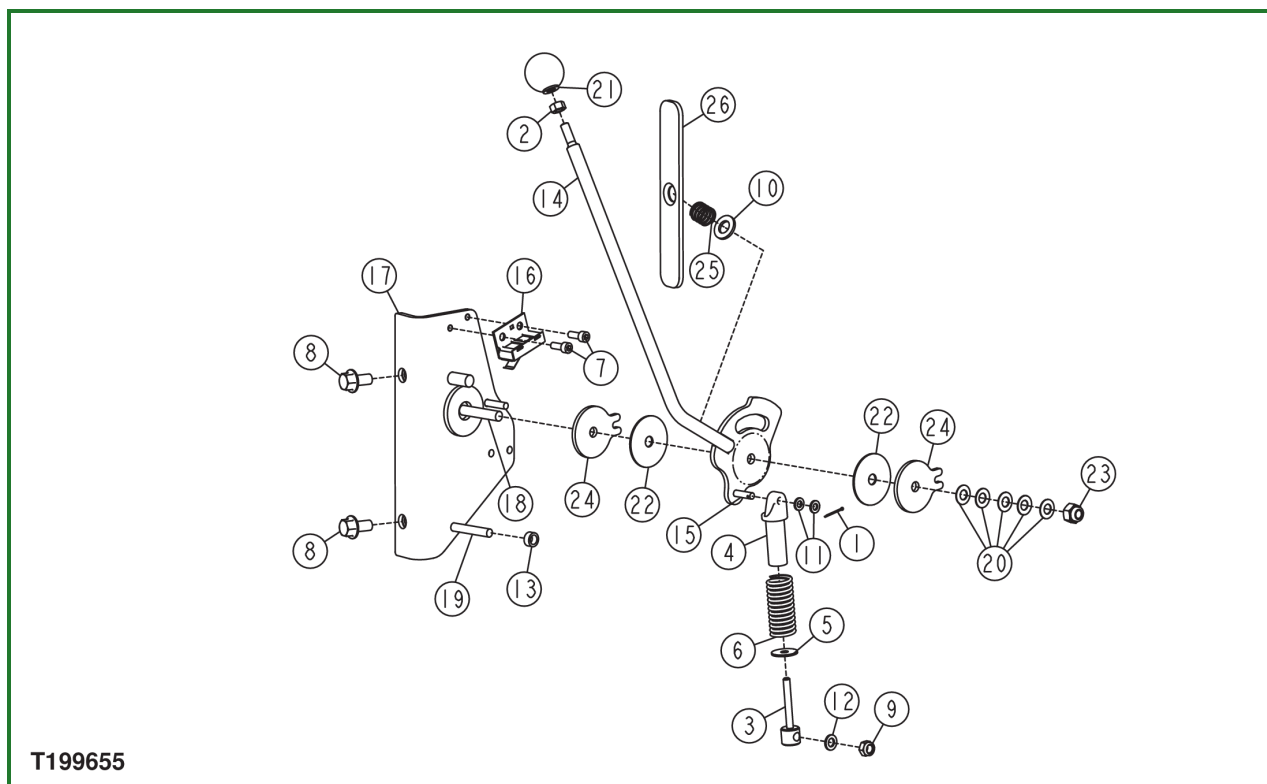
**T199655-UN: Park Lock Lever (exploded assembly)****LEGEND:**

- 1 - Cotter Pin
- 2 - Nut
- 3 - Pin Fastener
- 4 - Pin Fastener
- 5 - Washer
- 6 - Spring
- 7 - Hex Socket Head Cap Screw (2 used)
- 8 - Flanged Head Cap Screw (2 used)
- 9 - Lock Nut
- 10 - Washer
- 11 - Washer (2 used)
- 12 - Washer
- 13 - Washer
- 14 - Control Lever
- 15 - Stud
- 16 - Switch
- 17 - Bracket
- 18 - Threaded Stud
- 19 - Threaded Stud
- 20 - Spring Washer (5 used)
- 21 - Knob
- 22 - Washer (2 used)
- 23 - Lock Nut
- 24 - Plate (2 used)
- 25 - Compressing Spring
- 26 - Plate

27 - Washer

1. Lower all equipment to ground and stop engine.
2. Turn battery disconnect switch to OFF.
3. Remove park lock assembly. See [Park Lock Linkage Remove and Install](#) . (Group 1115.)
4. Remove plate (26), spring (25), and washer (10).
5. Remove lock nut (23), spring washers (20), plate (24), and washer (22).
6. Loosen lock nut (9) several turns. Do not remove.

7.

⚠ CAUTION:

*Park lock control lever is under spring pressure. Removing control lever without relieving spring pressure can cause bodily injury. Relieve spring pressure by **SLOWLY** removing control lever over stops and rotating lever over center.*

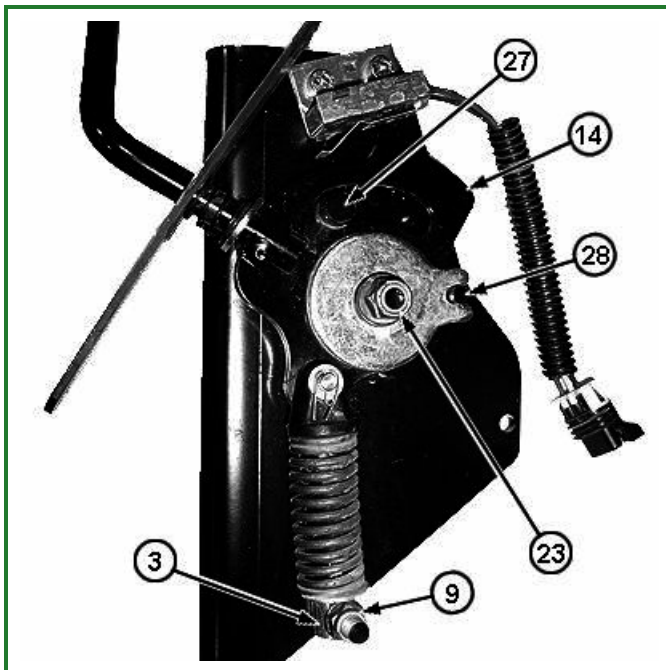

T199670A-UN: Park Lock Lever Assembly

LEGEND:

- 3 - Pin Fastener
- 9 - Lock Nut
- 14 - Control Lever
- 23 - Lock Nut
- 27 - Stop
- 28 - Stop

Using pry bar, lift control lever (14) and pin fastener (3) until control lever is higher than stops (27 and 28). This allows lever to rotate further and relieve spring tension.

8. Remove control lever (14), pin fastener (4), spring (6), and washer (5).

9. Disassemble remaining parts.
10. Assemble pin fastener (4) onto control lever stud (15) using washers (11) and cotter pin (1).
11. Assemble pin fastener (3) onto threaded stud (19) using washers (13 and 12), and lock nut (9). Do not tighten lock nut.
12. Assemble plate (24) and washer (22) onto threaded stud (18).
13. Assemble washer (5) and compression spring (6) onto pin fastener (3).
14. With pin fastener (4) slid into compression spring (6), assemble control lever onto threaded stud (18).
15. Rotate control lever until lever fits over stops (28 and 29). Push into place.
16. Tighten lock nut (9) to specification.

Item	Measurement	Specification
Lock Nut (M8)	Torque	Tighten lock nut until solid then loosen 1/2 turn.

17. Assemble washer (22) and plate (24) onto threaded stud (18).

18.

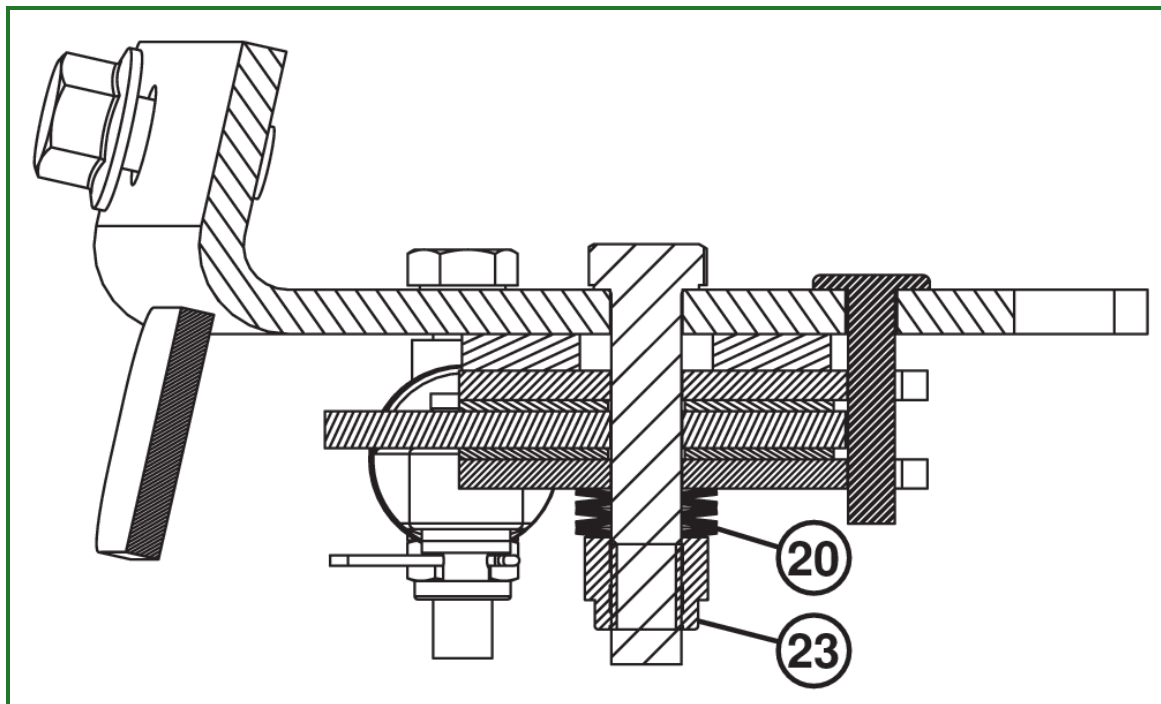

T199665-UN: Spring Washers

LEGEND:

- 20 - Spring Washers (5 used)
- 23 - Lock Nut

Assemble spring washers (20) as shown. Assemble lock nut (23) and tighten to specification.

Item	Measurement	Specification
Lock Nut (3/8)	Torque	Tighten lock nut until solid then loosen 1/2—2 turns.

19. Assemble switch (16) onto bracket using hex socket head cap screws (7). Tighten to specification.

Item	Measurement	Specification
Hex Socket Head Cap Screws	Torque	10.4 N·m 92 lb-in.

20. Assemble washer (10), and compression spring (25) onto control lever (14).
21. Assemble plate (26) onto control lever (14) with chamfer pointing away from spring.
22. Install park lock assembly. [See Park Lock Linkage Remove and Install](#) . (Group 1115.)

Go to [Section_11:Group_1115](#)

TE14778,000002C-19-20091203

Park Brake Valve Disassemble and Assemble

1.

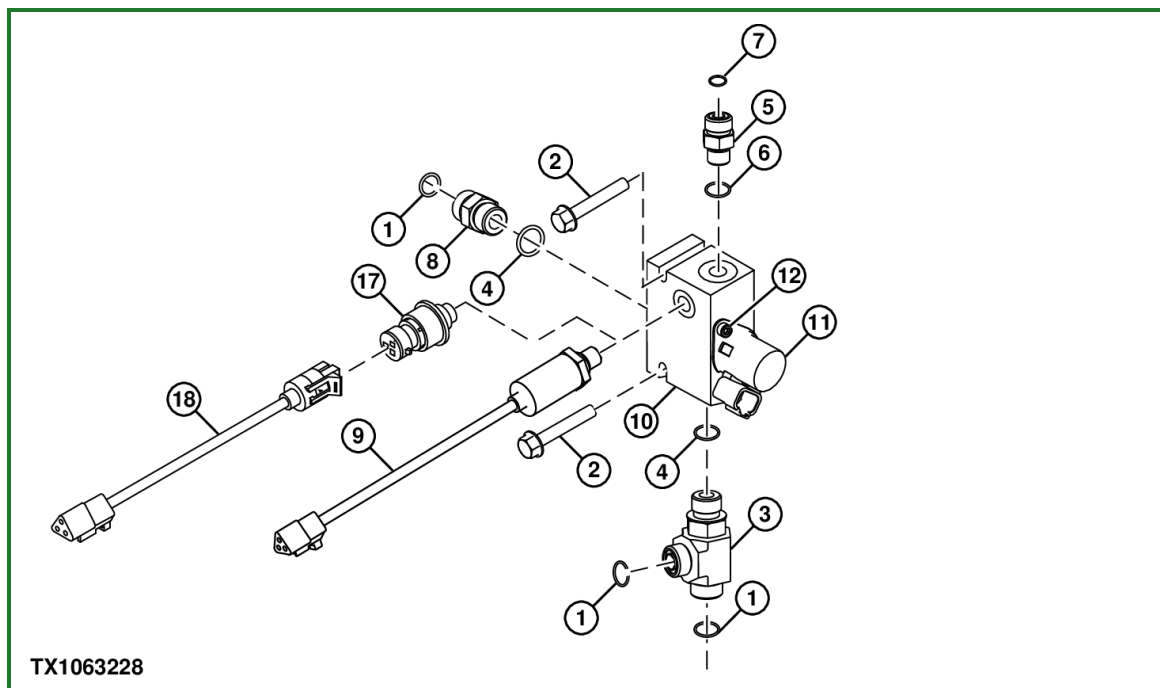

TX1063228-UN: Park Brake Valve

LEGEND:

- 1 - O-Ring (3 used)
- 2 - Cap Screw (2 used)
- 3 - Tee Fitting
- 4 - O-Ring (2 used)
- 5 - Adapter Fitting
- 6 - O-Ring
- 7 - O-Ring
- 8 - Adapter Fitting
- 9 - Charge Pressure Sensor (S.N. —173344)
- 10 - Park Brake Valve Housing
- 11 - Solenoid Valve
- 12 - Hex Socket Head Cap Screw (2 used)
- 17 - Charge Pressure Sensor (S.N. 173345—)
- 18 - Charge Pressure Sensor Harness (S.N. 173345—)

Mark position of hydraulic tee fitting (3) to aid in assembly, and remove.

2. Remove charge pressure sensor (9 or 17).
3. Remove adapter fittings (5 and 8).

4.

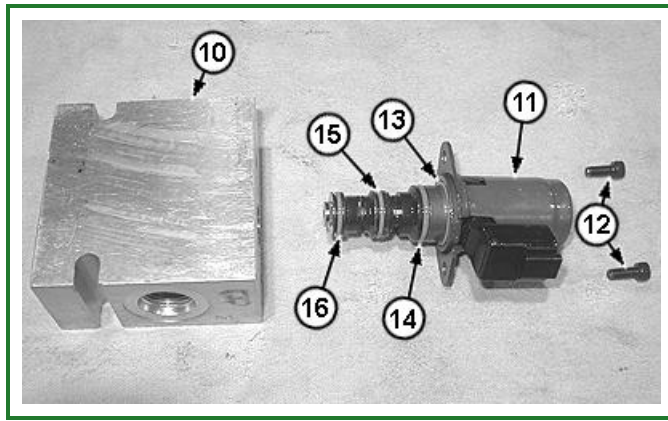

T199535A-UN: Park Brake Valve

LEGEND:

- 10 - Park Brake Valve Housing
- 11 - Solenoid Valve
- 12 - Hex Socket Head Cap Screw (2 used)
- 13 - O-Ring
- 14 - O-Ring
- 15 - O-Ring
- 16 - O-Ring

Remove hex socket head cap screws (12) and solenoid valve (11) from park brake valve housing (10).

5. Remove O-rings (13—16).
6. Clean and inspect parts. Replace as needed.
7. Lubricate parts with clean hydraulic oil.
8. Install O-rings (13—16) on solenoid valve.
9. Install solenoid valve (11) in park brake valve housing (10).
10. Clean threads of socket head cap screws (12). Apply PM37509 Cure Primer and PM37418 Thread Lock and Sealer (medium strength) to threads of socket head cap screw (12) and tighten to specification.

Item	Measurement	Specification
Park Brake Valve		
Spool Socket Head Cap Screw Torque		9 N·m 80 lb.-in.

11. Install adapter fittings (5 and 8).
12. Install charge pressure sensor (9 or 17) and tighten to specification.

Item	Measurement	Specification
Park Brake Valve		
Charge Pressure Sensor Torque		20 N·m 177 lb.-in.

13. Install tee fitting (3) in position as marked during removal.

Go to [Section_11:Group_1160](#)

TE14778,0000026-19-20100422

Park Brake Valve Disassemble and Assemble

1.

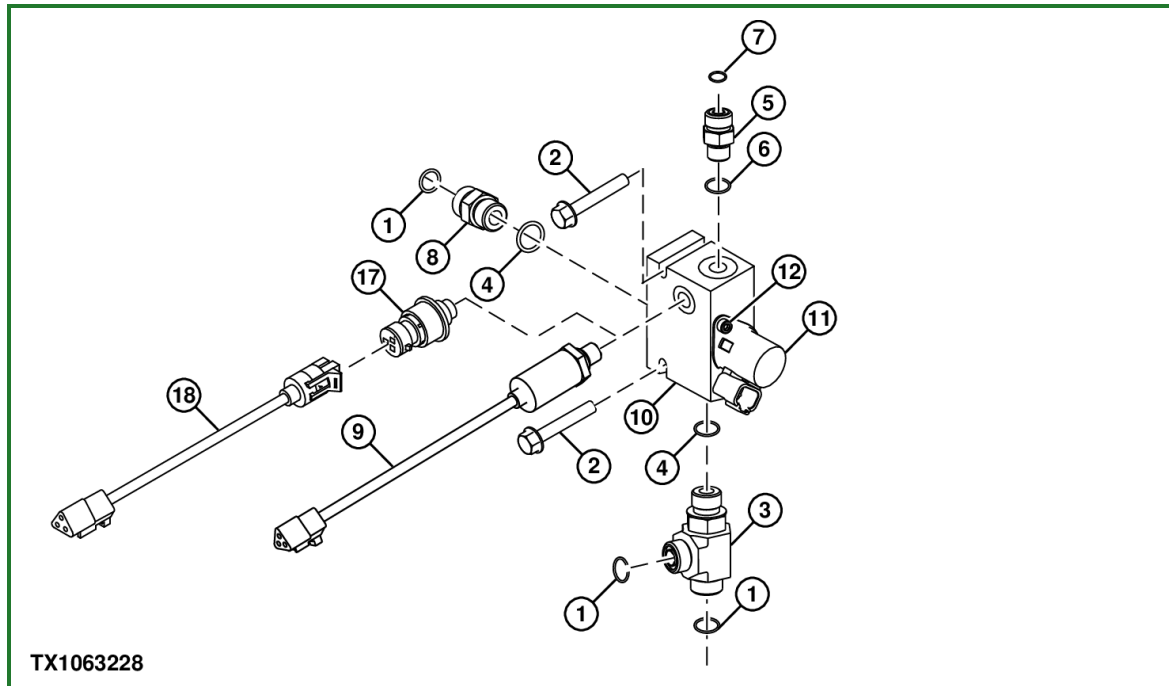

TX1063228-UN: Park Brake Valve

LEGEND:

- 1 - O-Ring (3 used)
- 2 - Cap Screw (2 used)
- 3 - Tee Fitting
- 4 - O-Ring (2 used)
- 5 - Adapter Fitting
- 6 - O-Ring
- 7 - O-Ring
- 8 - Adapter Fitting
- 9 - Charge Pressure Sensor (S.N. —173344)
- 10 - Park Brake Valve Housing
- 11 - Solenoid Valve
- 12 - Hex Socket Head Cap Screw (2 used)
- 17 - Charge Pressure Sensor (S.N. 173345—)
- 18 - Charge Pressure Sensor Harness (S.N. 173345—)

Mark position of hydraulic tee fitting (3) to aid in assembly, and remove.

2. Remove charge pressure sensor (9 or 17).
3. Remove adapter fittings (5 and 8).

4.

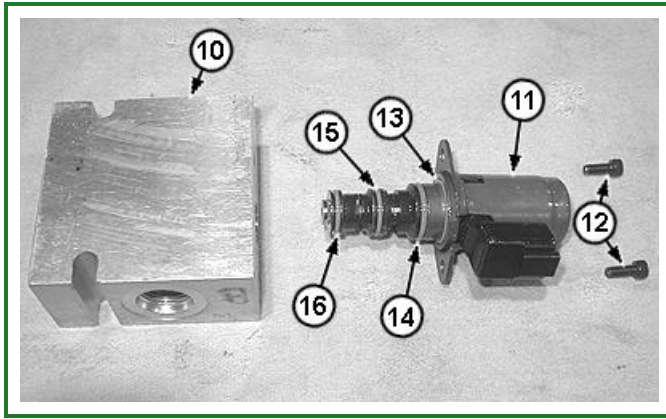

T199535A-UN: Park Brake Valve

LEGEND:

- 10 - Park Brake Valve Housing
- 11 - Solenoid Valve
- 12 - Hex Socket Head Cap Screw (2 used)
- 13 - O-Ring
- 14 - O-Ring
- 15 - O-Ring
- 16 - O-Ring

Remove hex socket head cap screws (12) and solenoid valve (11) from park brake valve housing (10).

5. Remove O-rings (13—16).
6. Clean and inspect parts. Replace as needed.
7. Lubricate parts with clean hydraulic oil.
8. Install O-rings (13—16) on solenoid valve.
9. Install solenoid valve (11) in park brake valve housing (10).
10. Clean threads of socket head cap screws (12). Apply PM37509 Cure Primer and PM37418 Thread Lock and Sealer (medium strength) to threads of socket head cap screw (12) and tighten to specification.

Item	Measurement	Specification
Park Brake Valve		
Spool Socket Head Cap Screw Torque		9 N·m 80 lb.-in.

11. Install adapter fittings (5 and 8).
12. Install charge pressure sensor (9 or 17) and tighten to specification.

Item	Measurement	Specification
Park Brake Valve		
Charge Pressure Sensor Torque		20 N·m 177 lb.-in.

13. Install tee fitting (3) in position as marked during removal.

Go to [Section_11:Group_1160](#)

TE14778,0000026-19-20100422

Park Brake Disassemble and Assemble

1. Remove park brake. See [Park Brake Remove and Install](#) . (Group 1100.)
2. Scribe a line between cover and housing to aid assembly.

3.

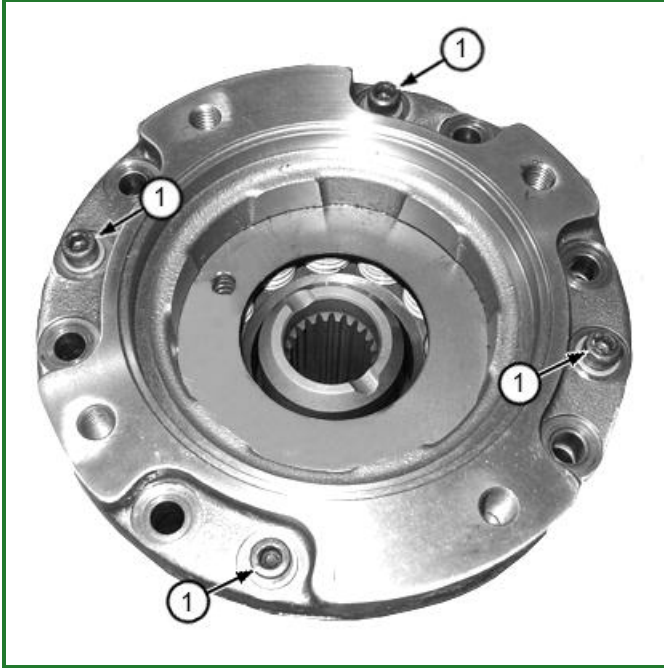

T198544A-UN: Brake Assembly

LEGEND:

1 - Socket Head Cap Screw and Washer (4 used)

Remove four socket head cap screws and washers (1) and separate cover from housing.

4. Remove O-ring from cover.

5.



T198545A-UN: Spring Retainer Plate

LEGEND:

1 - Spring Retainer Plate

Remove spring retainer plate (1).

6.

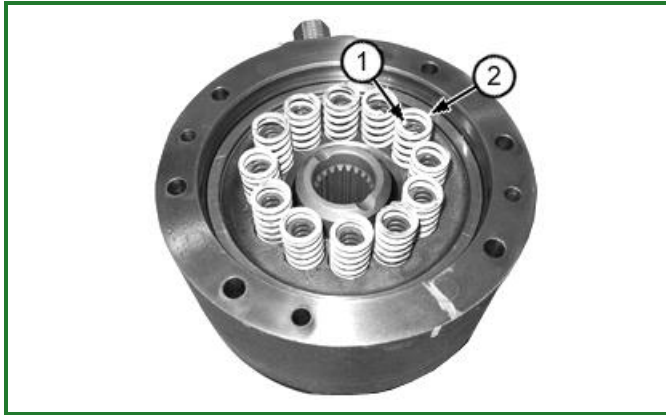

T198546A-UN: Springs

LEGEND:

1 - Springs (12 used)

2 - Springs (12 used)

Remove springs (1 and 2).

7.



T198548A-UN: Piston

LEGEND:

1 - Piston

Remove piston (1).

8.



T198550A-UN: Piston O-Rings

LEGEND:

- 1 - O-Ring
- 2 - O-Ring

Remove O-rings (1 and 2) from piston.

9.

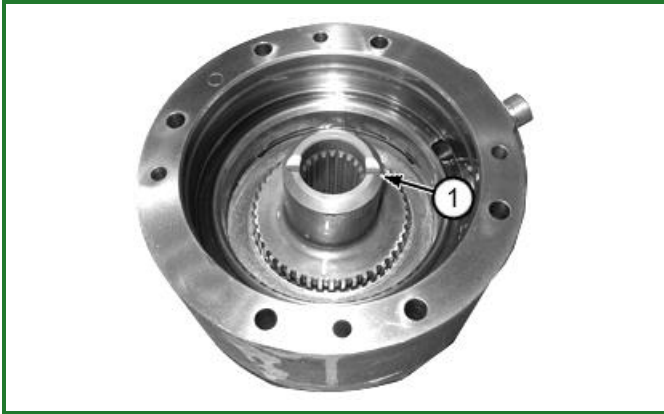

T198549A-UN: Splined Coupling

LEGEND:

- 1 - Splined Coupling

Remove splined coupling (1).

10. Scribe a line between quill and housing to aid assembly.

11.

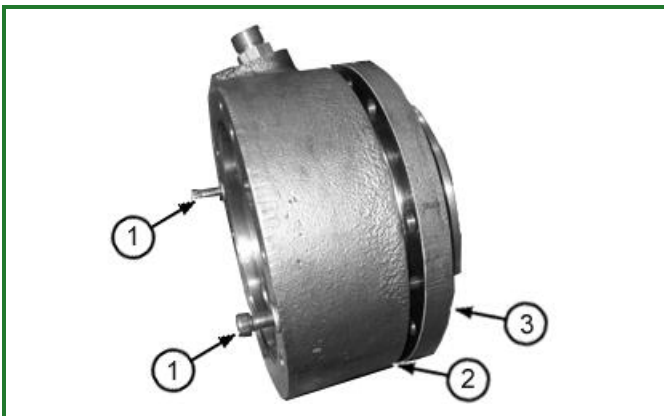

T198551A-UN: Separate Housings

LEGEND:

- 1 - Screw (2 used)
- 2 - Housing
- 3 - Quill

Insert two screws (1) through housing (2) into quill. Tap screws with plastic hammer to separate quill from housing.

12.

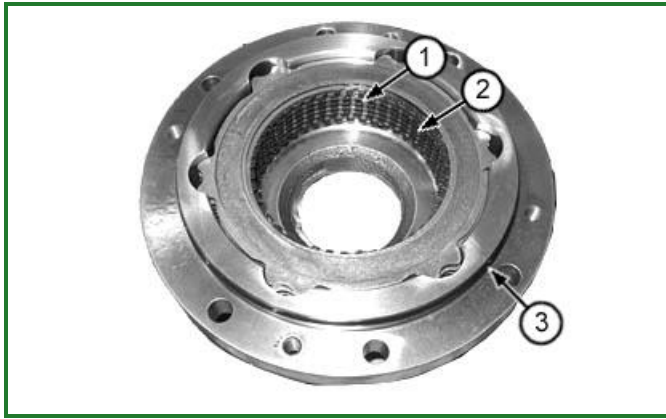
**T198552A-UN: Disks and Separator Plates****LEGEND:**

- 1 - Friction Disk (7 used)
- 2 - Separator Plate (8 used)
- 3 - O-Ring

Remove friction disks (1) and separator plates (2) from housing.

Remove O-ring (3).

13. Clean and inspect parts.

14. Install splined coupling in quill.

15. Install a separator plate, then a friction disk, and continue alternating plates and disks until all are installed in quill.

16. Install O-ring on quill.

17. Apply clean hydraulic oil to O-ring, quill, and housing.

18. Install housing onto quill.

19. Install O-rings on piston.

20. Apply clean hydraulic oil to piston, O-rings, and housing.

21. Install piston in housing.

22. Install double springs into piston.

23. Install spring retainer onto springs.

24. Install O-ring on cover.

25. Apply clean hydraulic oil to cover, O-ring, and housing.

26. Install cover in housing.

27. Install cap screws and washers. Tighten cap screws to specification.

Item	Measurement	Specification
Park Brake		
Park Brake Assembly Socket Head Cap Screw	Torque	37 N·m 27 lb-ft

Go to [Section_11:Group_1160](#)

TE14778,0000025-19-20060418

Section 18: Operator's Station

Group 1800: Removal and Installation

Cab or ROPS Remove and Install

Group 1810: Operator's Enclosure

Slide Glass Remove and Install

Stationary Glass Remove and Install

Sliding Window Remove and Install

Front Window Wiper Remove and Install

Door Window Wipers Remove and Install

Rear Window Wiper Remove and Install

Window Washer Pumps Remove and Install

Group 1821: Seat and Seat Belt

Standard Seat Remove and Install (Old)

Deluxe Seat Remove and Install

Air Suspension Seat Remove and Install

Group 1830: Heating and Air Conditioning

R134a Refrigerant Cautions

R134a Compressor Oil Charge Check

R134a Compressor Oil Removal

R134a Component Oil Charge

Leakage Testing

R134a Refrigerant Recovery, Recycling and Charging Station Installation Procedure

Recover R134a System

Evacuate R134a System

Charge R134a System

Air Conditioner System Cleaning Procedures

Purge R134a System

Flush R134a System

Evaporator or Heater Core Remove and Install

Expansion Valve Remove and Install

A/C Freeze Switch Remove and Install

Upper Cab Heater Blower Motor and Heater Blower Resistor Remove and Install

Cab Upper Heater Disassemble and Assemble

Cab or ROPS Under Seat Heater Disassemble and Assemble

Receiver-Dryer Remove and Install

Condenser Remove and Install

Compressor Remove and Install

Compressor Remove and Install

Compressor Clutch Disassemble and Assemble

Clutch Hub Clearance Check

Compressor Manifold Inspect

Compressor Disassemble and Assemble

Cab or ROPS Remove and Install

-: Specifications

SPECIFICATIONS	
Cooling System Capacity	11.3 L 12 qt
Cab/ROPS	
Cab Weight	703 kg 1550 lb
ROPS Weight	499 kg 1100 lb
Cab/ROPS Mounting Cap Screws Torque	624 N·m 460 lb-ft

-: Service Equipment and Tools

SERVICE EQUIPMENT AND TOOLS
JT05552 Lifting Eyebolts

1. Drain engine coolant.

Item	Measurement	Specification
Cooling System Capacity	11.3 L 12 qt	

2. **For Cabs Equipped With Air Conditioning System:**

Evacuate air conditioning system. [See Evacuate R134a System](#) . (Group 1830.)

3. Remove engine side shields and precleaner cover from machine.
4. Remove floor mat and floor plate from machine.

- 5.

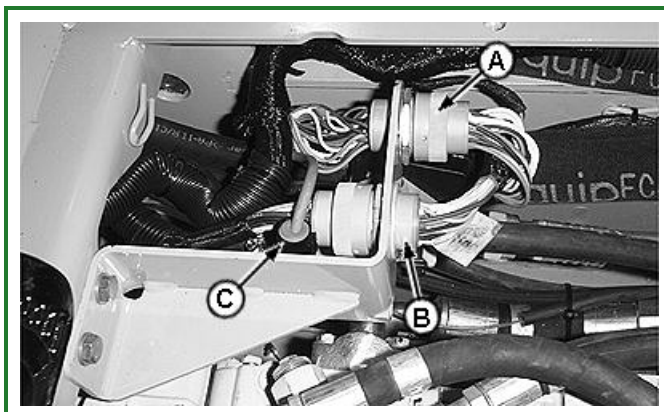

T116814B-UN: Main Wiring Harness Connectors

LEGEND:

- A - Transmission Main Wiring Harness Connector
- B - Engine Main Wiring Harness Connector
- C - Cable

Disconnect transmission and engine main wiring harness connectors (A and B) and cable (C).

6.

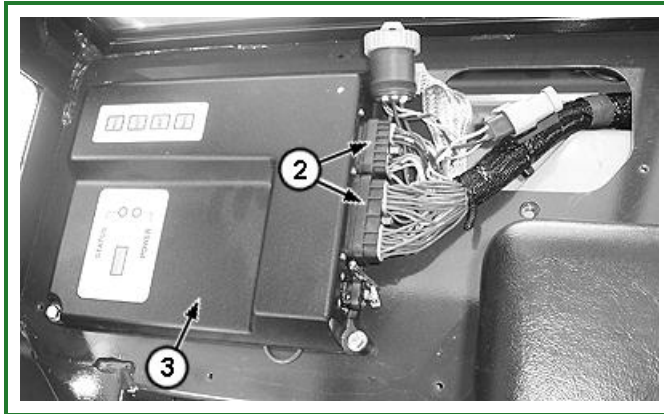

T200481A-UN: Transmission Controller

LEGEND:

- 2 - Wiring Harness (2 used)
- 3 - Transmission Controller

Remove transmission controller cover.

7. Disconnect wiring harnesses (2) from transmission controller (3).

8.

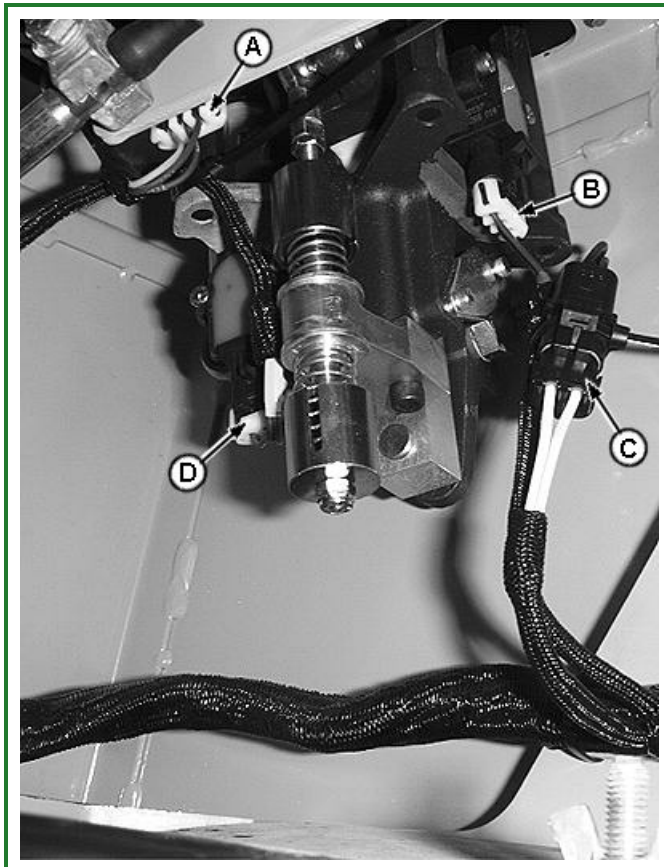

T116726B-UN: Four Wire Connectors

LEGEND:

A - B4 Transmission Speed Control Sensor. T07 Blue, T04 Blue, Z04 Gray Wires

B - B5 Left And Right Steer Sensor. (Marked BLUE on housing below sensor.) T10 Blue, T11 Blue, Z05 Gray Wires

C - S3 Neutral Start Switch. E09B White Wire, E03B White Wire

D - B2 FNR Sensor. (Marked YELLOW on housing below sensor.) T01 Blue, T02 Blue, Z01 Gray Wires

Disconnect four wire connectors (A—D) from single lever controller (SLC). To aid in assembly, tag wires for proper location.

9. On machines equipped with dual batteries, remove rear battery.
10. Remove fuel cap and rubber boot from filler neck.
11. Remove hydraulic control tee handle.

12.

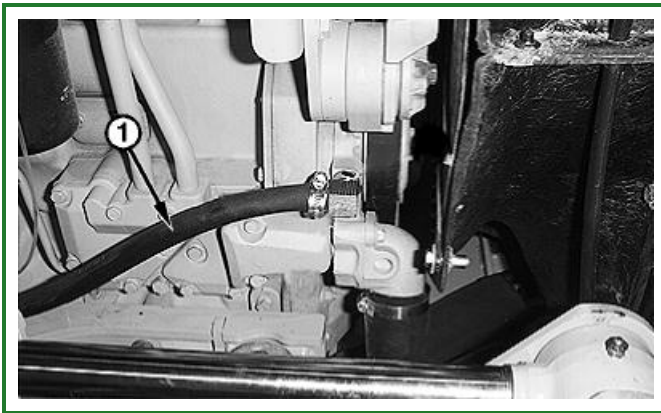

T116813C-UN: Engine Heater Hose

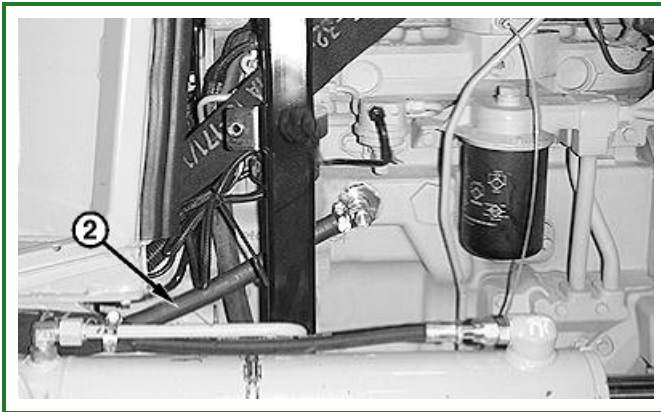

T117195C-UN: Engine Heater Hose

LEGEND:

1 - Heater Hose

2 - Heater Hose

Disconnect hoses (1) and (2) from engine.

13.



T118601B-UN: Air Conditioning Hoses

LEGEND:

1 - Air Conditioning Hose (2 used)

Remove two cap screws on rear light plate and backup alarm bracket. Allow bracket to hang out back of cab.

14. **For Cabs Equipped With Air Conditioning System:**

Disconnect air conditioning hoses (1).

15. Cap and plug all openings.

16.

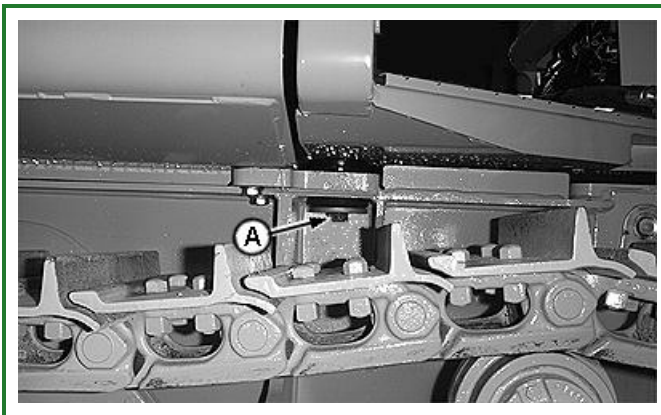

T116733B-UN: Mounting Cap Screw

LEGEND:

A - Mounting Cap Screw (4 used)

Remove four mounting cap screws (A) and rubber mounts.

17.

⚠ CAUTION:

Prevent possible crushing injury from cab. Use appropriate lifting device.

Item	Measurement	Specification
Cab/ROPS		
Cab	Weight	703 kg 1550 lb
ROPS	Weight	499 kg 1100 lb

IMPORTANT:

Cab/ROPS should be removed with rear end slightly higher than front end to avoid damaging rear of fuel tank.

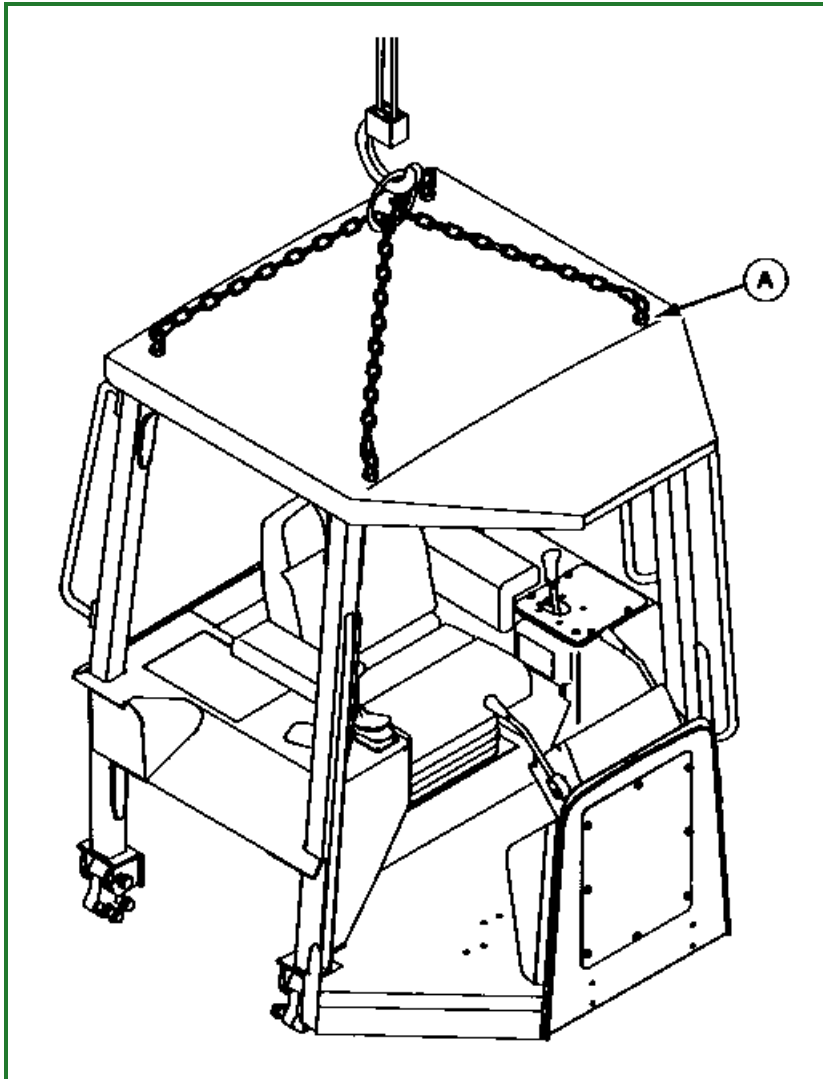

T8388AH-UN: JT05552 Lifting Eyebolts

LEGEND:

A - JT05552 Lifting Eyebolts (4 used)

Install four JT05552 Lifting Eyebolts (A) in top of cab/ROPS.

18. Attach chain and slowly raise cab/ROPS up.

19. Remove cab or ROPS.

20. **IMPORTANT:**

Prevent possible damage to rear of fuel tank. Cab/ROPS should be installed with rear end slightly higher than front end.

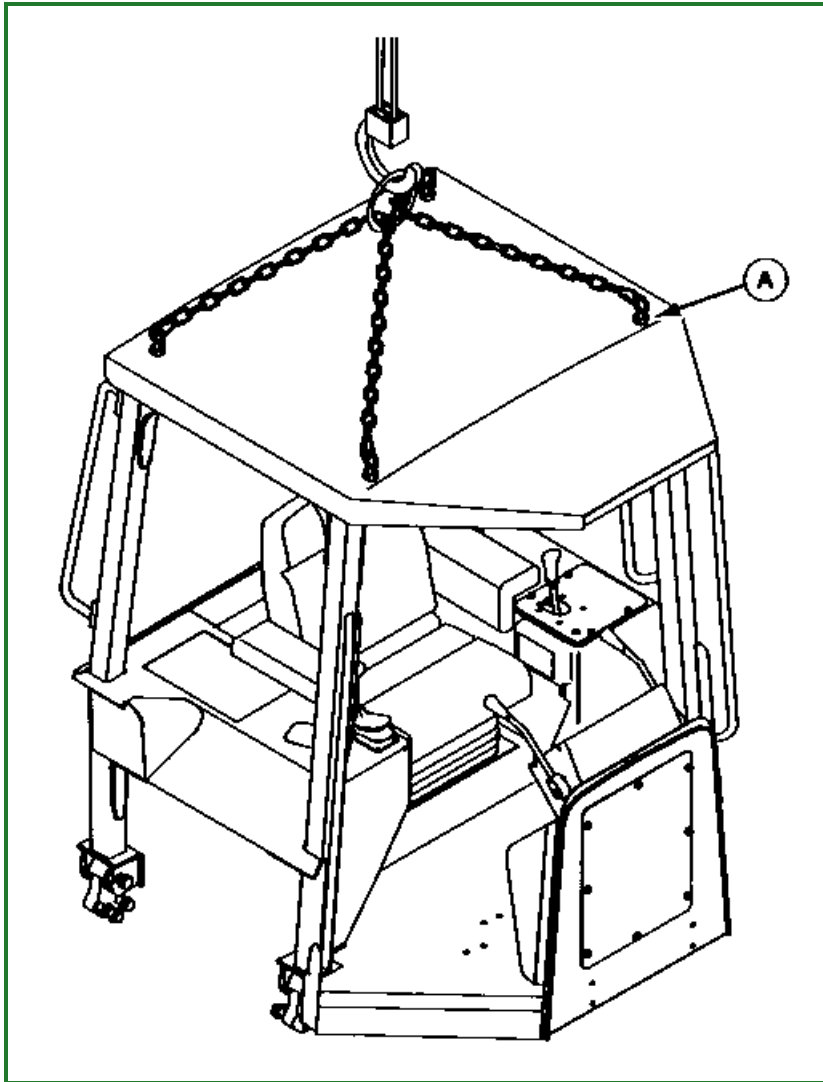

T8388AH-UN: Lifting Eyebolts

LEGEND:

A - Lifting Eyebolts (4 used)

Install four lifting eyebolts (A) in top of cab/ROPS. Install chain and hoist.

Item	Measurement	Specification
Cab/ROPS		
Cab	Weight	703 kg
		1550 lb
ROPS	Weight	499 kg
		1100 lb

21. Slowly begin to lower cab/ROPS into place on machine.
22. When installing cab/ROPS, route all wiring harnesses back to their original location and replace all tie bands that were removed.

23.

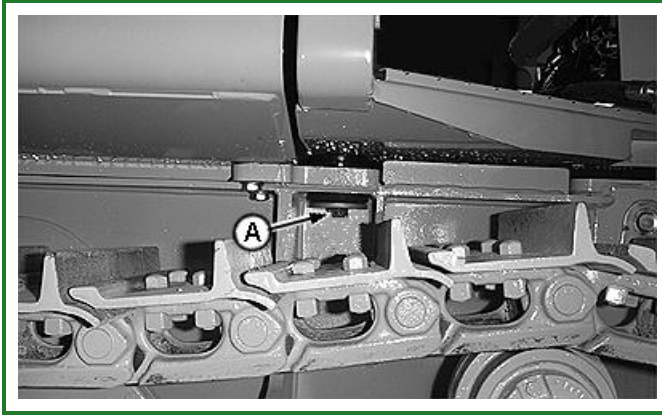

T116733B-UN: Mounting Cap Screw

LEGEND:

A - Mounting Cap Screw (4 used)

Install cab/ROPS to machine with four mounting cap screws (A) and rubber isolators. Tighten cap screws to specification.

Item	Measurement	Specification
Cab/ROPS		
Cab/ROPS Mounting Cap Screws Torque		624 N·m 460 lb-ft

24.

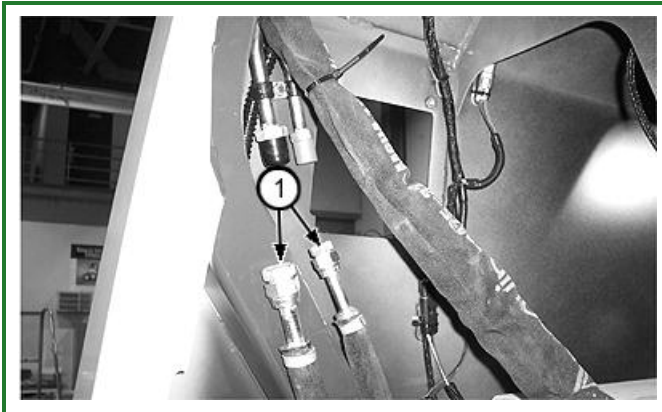

T200472A-UN: Air Conditioner Hoses

LEGEND:

1 - Air Conditioning Hose (2 used)

For Cabs Equipped With Air Conditioning System:

Verify O-rings are present and in good condition on air conditioning hoses and apply refrigerant oil.

Connect air conditioning hoses (1) as shown.

25. Install rear light plate and backup alarm bracket to cab using two cap screws.

26.

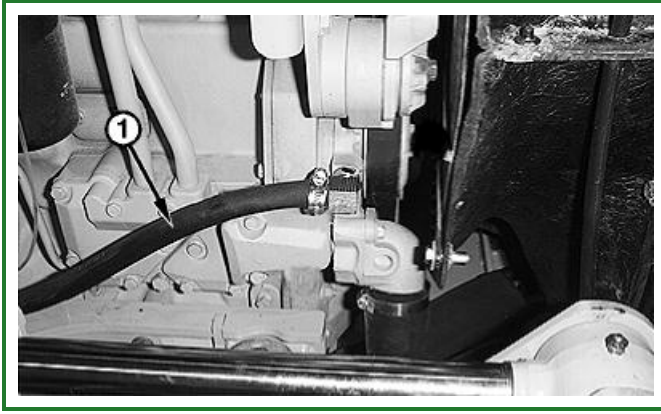

T116813C-UN: Engine Heater Hose

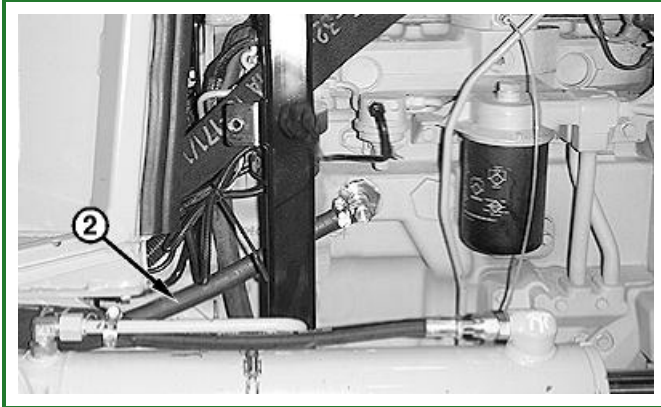

T117195C-UN: Engine Heater Hose

LEGEND:

1 - Heater Hose

2 - Heater Hose

Connect heater hoses (1) and (2) to engine.

27. Install boot and hydraulic control tee handle.

28. On machines equipped with dual batteries, install rear battery.

29.

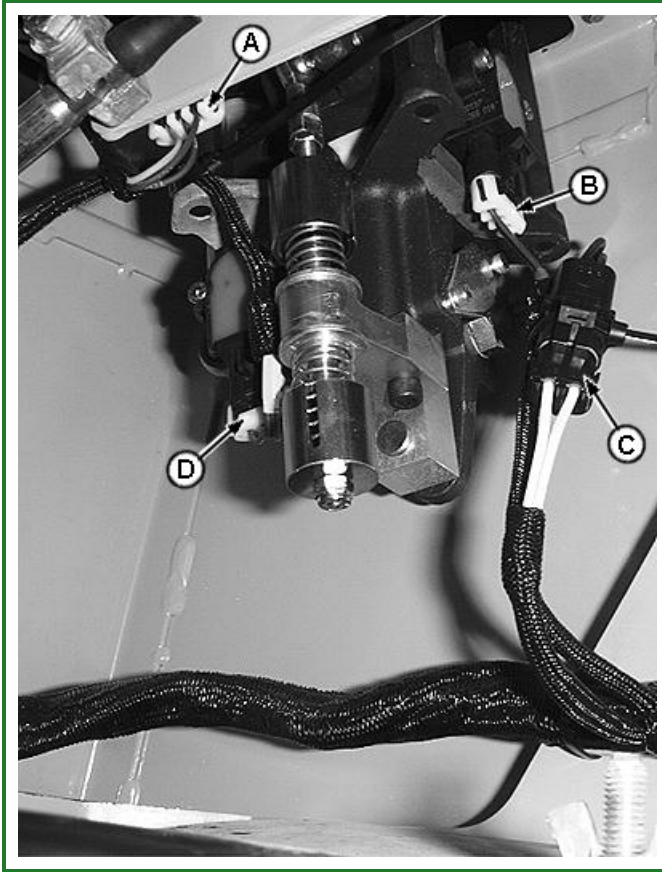

T116726B-UN: Four Wire Connectors

LEGEND:

A - B4 Transmission Speed Control Sensor. T07 Blue, T04 Blue, Z04 Gray Wires

B - B5 Left And Right Steer Sensor. (Marked BLUE on housing below sensor.) T10 Blue, T11 Blue, Z05 Gray Wires

C - S3 Neutral Start Switch. E09B White Wire, E03B White Wire

D - B2 FNR Sensor. (Marked YELLOW on housing below sensor.) T01 Blue, T02 Blue, Z01 Gray Wires

Connect four wire connectors (A—D) on single lever control (SLC).

30.

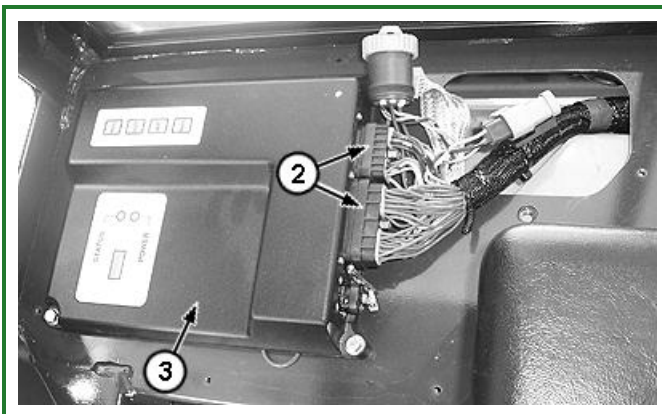

T200481A-UN: Transmission Controller

LEGEND:

2 - Wiring Harness (2 used)

3 - Transmission Controller

Connect wiring harnesses (2) to transmission controller (3).

31. Install transmission controller cover.

32.

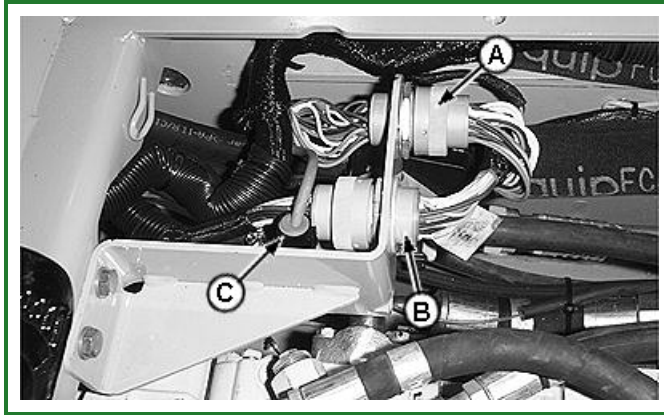

T116814B-UN: Main Wiring Harness Connectors

LEGEND:

- A - Transmission Main Wiring Harness Connector
- B - Engine Main Wiring Harness Connector
- C - Cable

Connect transmission and engine main wiring harness connectors (A and B) and cable (C).

33. Install floor plate and floor mat.

34. Install molding strip to front of cab/ROPS.

35. Fill engine coolant.

Item	Measurement	Specification
Cab/ROPS		
Cooling System Capacity		11.3 L 12 qt

36. Install engine side shields and precleaner cover.

37. Install boot on fuel filler neck and install fuel cap.

38. **For Cabs Equipped With Air Conditioning System:**

Charge air conditioning system. [See Charge R134a System](#) . (Group 1830.)

Go to [Section_18:Group_1800](#)

CED, TX03399, 5019-19-19990406

Cab or ROPS Remove and Install

-: Specifications

SPECIFICATIONS	
Cooling System Capacity	11.3 L 12 qt
Cab/ROPS	
Cab Weight	703 kg 1550 lb
ROPS Weight	499 kg 1100 lb
Cab/ROPS Mounting Cap Screws Torque	624 N·m 460 lb-ft

-: Service Equipment and Tools

SERVICE EQUIPMENT AND TOOLS
JT05552 Lifting Eyebolts

1. Drain engine coolant.

Item	Measurement	Specification
Cooling System Capacity	11.3 L 12 qt	

2. **For Cabs Equipped With Air Conditioning System:**

Evacuate air conditioning system. [See Evacuate R134a System](#) . (Group 1830.)

3. Remove engine side shields and precleaner cover from machine.
4. Remove floor mat and floor plate from machine.

- 5.

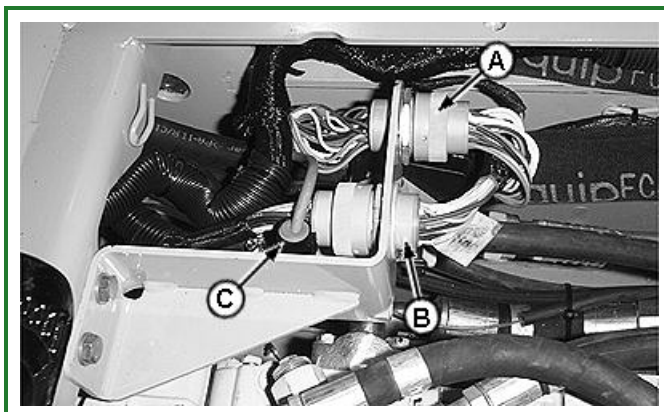

T116814B-UN: Main Wiring Harness Connectors

LEGEND:

- A - Transmission Main Wiring Harness Connector
- B - Engine Main Wiring Harness Connector
- C - Cable

Disconnect transmission and engine main wiring harness connectors (A and B) and cable (C).

6.

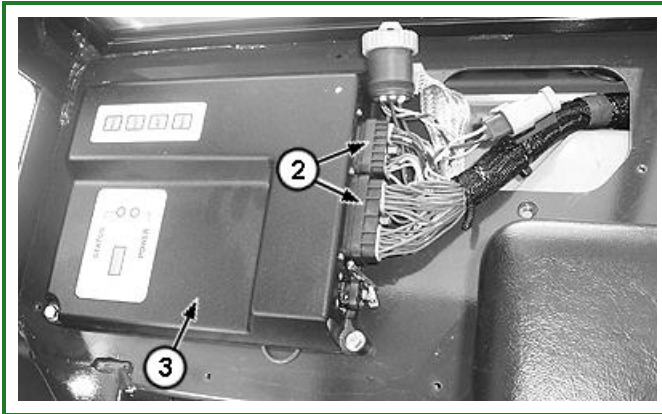

T200481A-UN: Transmission Controller

LEGEND:

- 2 - Wiring Harness (2 used)
- 3 - Transmission Controller

Remove transmission controller cover.

7. Disconnect wiring harnesses (2) from transmission controller (3).

8.

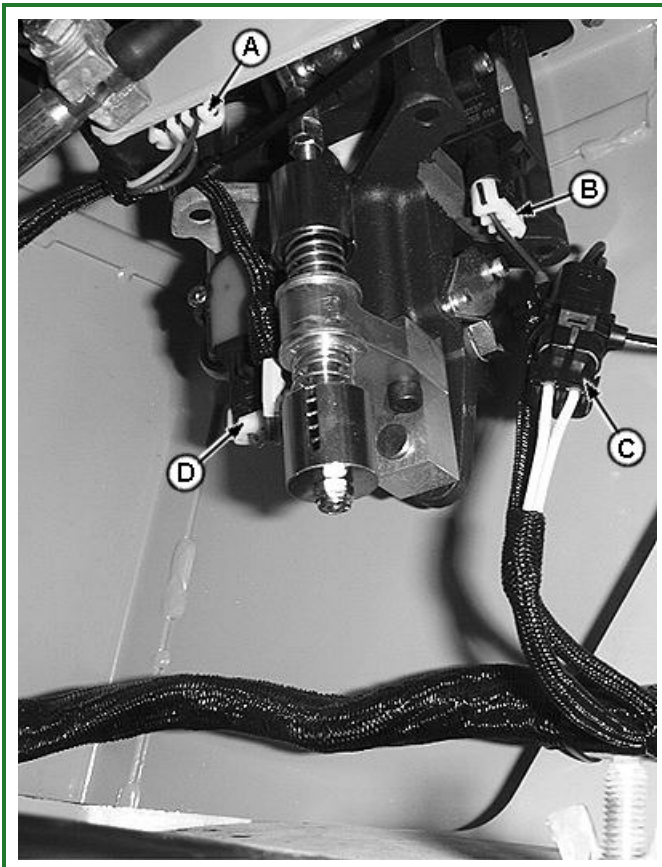

T116726B-UN: Four Wire Connectors

LEGEND:

A - B4 Transmission Speed Control Sensor. T07 Blue, T04 Blue, Z04 Gray Wires

B - B5 Left And Right Steer Sensor. (Marked BLUE on housing below sensor.) T10 Blue, T11 Blue, Z05 Gray Wires

C - S3 Neutral Start Switch. E09B White Wire, E03B White Wire

D - B2 FNR Sensor. (Marked YELLOW on housing below sensor.) T01 Blue, T02 Blue, Z01 Gray Wires

Disconnect four wire connectors (A—D) from single lever controller (SLC). To aid in assembly, tag wires for proper location.

9. On machines equipped with dual batteries, remove rear battery.
10. Remove fuel cap and rubber boot from filler neck.
11. Remove hydraulic control tee handle.

12.

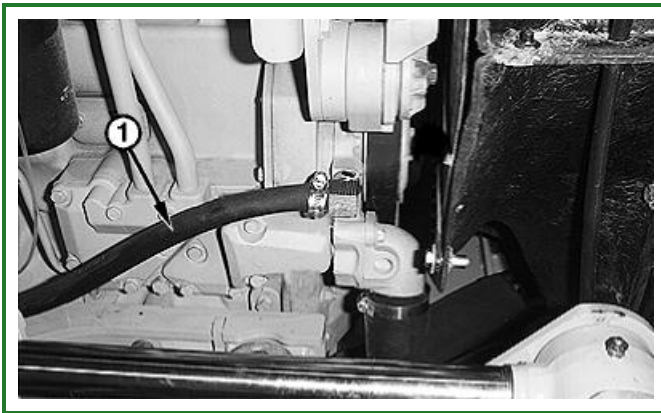

T116813C-UN: Engine Heater Hose

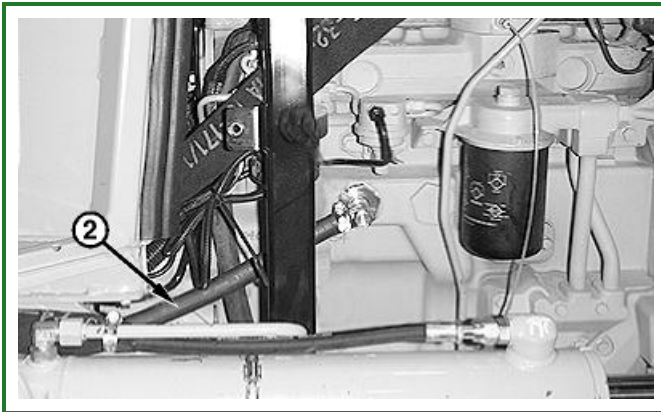

T117195C-UN: Engine Heater Hose

LEGEND:

- 1 - Heater Hose
- 2 - Heater Hose

Disconnect hoses (1) and (2) from engine.

13.



T118601B-UN: Air Conditioning Hoses

LEGEND:

1 - Air Conditioning Hose (2 used)

Remove two cap screws on rear light plate and backup alarm bracket. Allow bracket to hang out back of cab.

14. **For Cabs Equipped With Air Conditioning System:**

Disconnect air conditioning hoses (1).

15. Cap and plug all openings.

16.

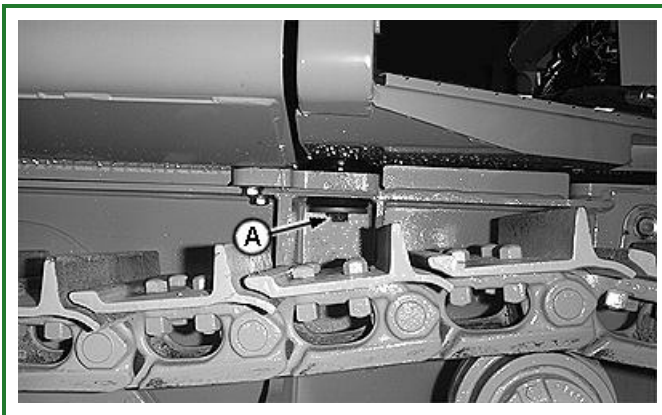

T116733B-UN: Mounting Cap Screw

LEGEND:

A - Mounting Cap Screw (4 used)

Remove four mounting cap screws (A) and rubber mounts.

17.

⚠ CAUTION:

Prevent possible crushing injury from cab. Use appropriate lifting device.

Item	Measurement	Specification
Cab/ROPS		
Cab	Weight	703 kg 1550 lb
ROPS	Weight	499 kg 1100 lb

IMPORTANT:

Cab/ROPS should be removed with rear end slightly higher than front end to avoid damaging rear of fuel tank.

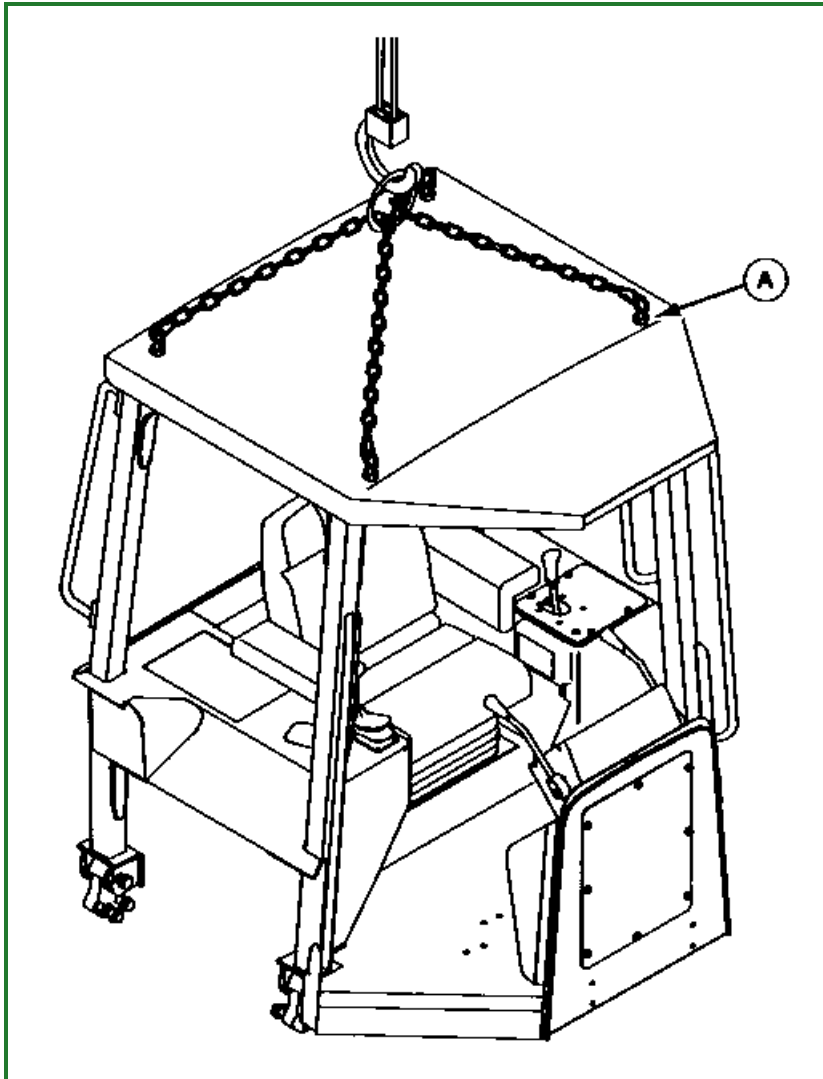

T8388AH-UN: JT05552 Lifting Eyebolts

LEGEND:

A - JT05552 Lifting Eyebolts (4 used)

Install four JT05552 Lifting Eyebolts (A) in top of cab/ROPS.

18. Attach chain and slowly raise cab/ROPS up.

19. Remove cab or ROPS.

20. **IMPORTANT:**

Prevent possible damage to rear of fuel tank. Cab/ROPS should be installed with rear end slightly higher than front end.

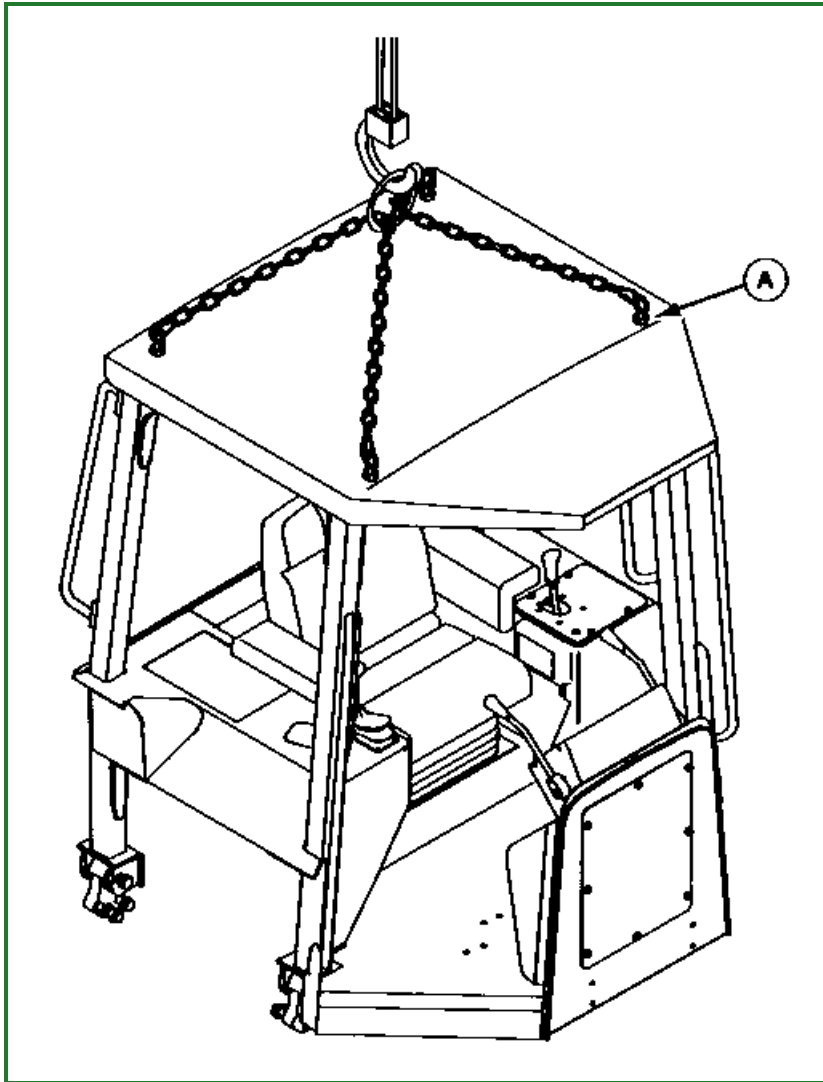

T8388AH-UN: Lifting Eyebolts

LEGEND:

A - Lifting Eyebolts (4 used)

Install four lifting eyebolts (A) in top of cab/ROPS. Install chain and hoist.

Item	Measurement	Specification
Cab/ROPS		
Cab	Weight	703 kg 1550 lb
ROPS	Weight	499 kg 1100 lb

21. Slowly begin to lower cab/ROPS into place on machine.
22. When installing cab/ROPS, route all wiring harnesses back to their original location and replace all tie bands that were removed.

23.

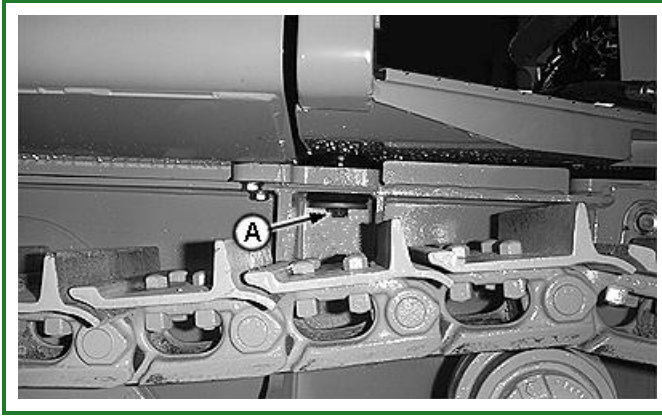

T116733B-UN: Mounting Cap Screw

LEGEND:

A - Mounting Cap Screw (4 used)

Install cab/ROPS to machine with four mounting cap screws (A) and rubber isolators. Tighten cap screws to specification.

Item	Measurement	Specification
Cab/ROPS		
Cab/ROPS Mounting Cap Screws Torque		624 N·m 460 lb-ft

24.

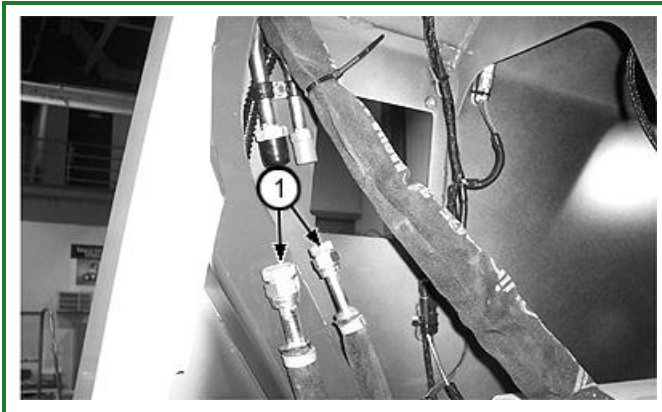

T200472A-UN: Air Conditioner Hoses

LEGEND:

1 - Air Conditioning Hose (2 used)

For Cabs Equipped With Air Conditioning System:

Verify O-rings are present and in good condition on air conditioning hoses and apply refrigerant oil.

Connect air conditioning hoses (1) as shown.

25. Install rear light plate and backup alarm bracket to cab using two cap screws.

26.

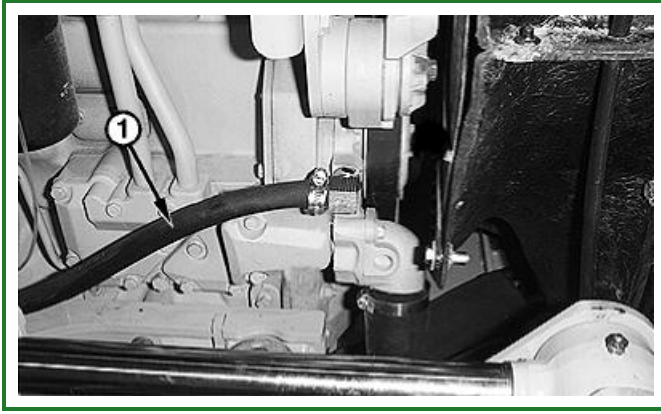

T116813C-UN: Engine Heater Hose

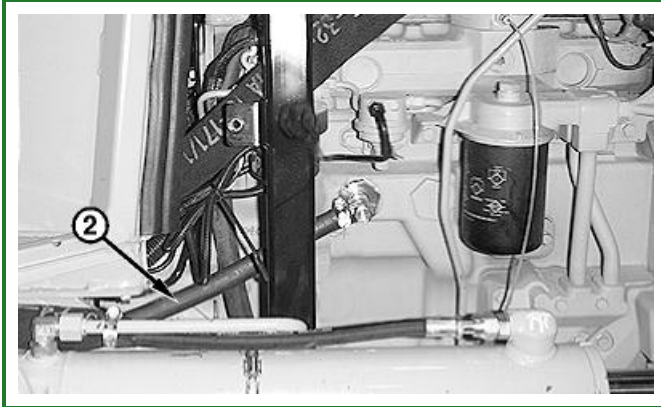

T117195C-UN: Engine Heater Hose

LEGEND:

1 - Heater Hose

2 - Heater Hose

Connect heater hoses (1) and (2) to engine.

27. Install boot and hydraulic control tee handle.

28. On machines equipped with dual batteries, install rear battery.

29.

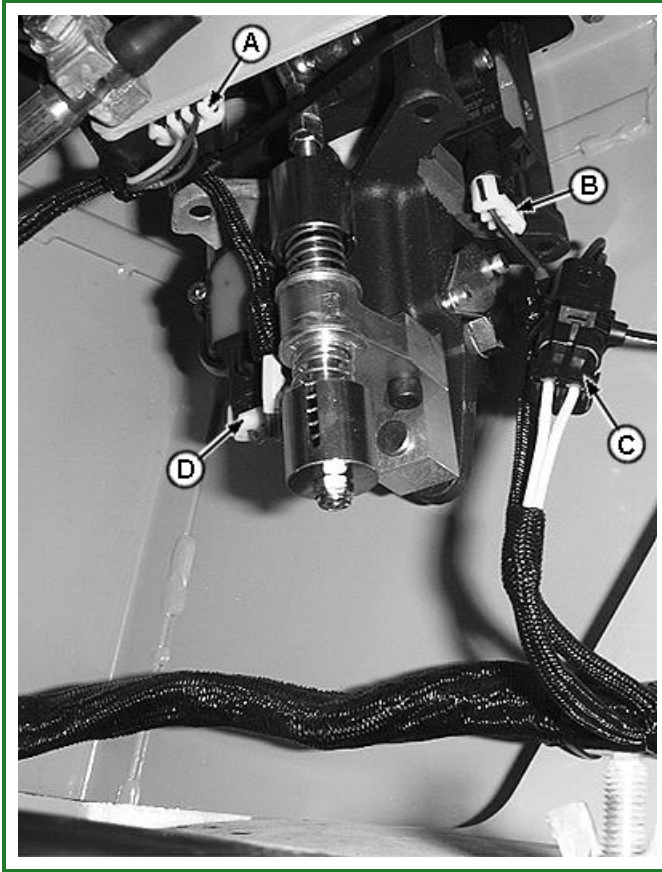

T116726B-UN: Four Wire Connectors

LEGEND:

A - B4 Transmission Speed Control Sensor. T07 Blue, T04 Blue, Z04 Gray Wires

B - B5 Left And Right Steer Sensor. (Marked BLUE on housing below sensor.) T10 Blue, T11 Blue, Z05 Gray Wires

C - S3 Neutral Start Switch. E09B White Wire, E03B White Wire

D - B2 FNR Sensor. (Marked YELLOW on housing below sensor.) T01 Blue, T02 Blue, Z01 Gray Wires

Connect four wire connectors (A—D) on single lever control (SLC).

30.

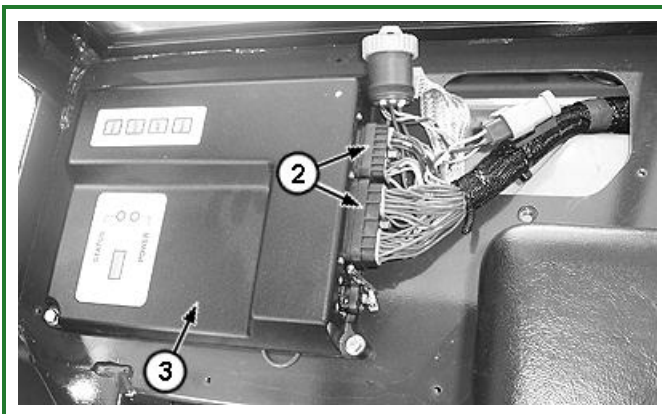

T200481A-UN: Transmission Controller

LEGEND:

2 - Wiring Harness (2 used)

3 - Transmission Controller

Connect wiring harnesses (2) to transmission controller (3).

31. Install transmission controller cover.

32.

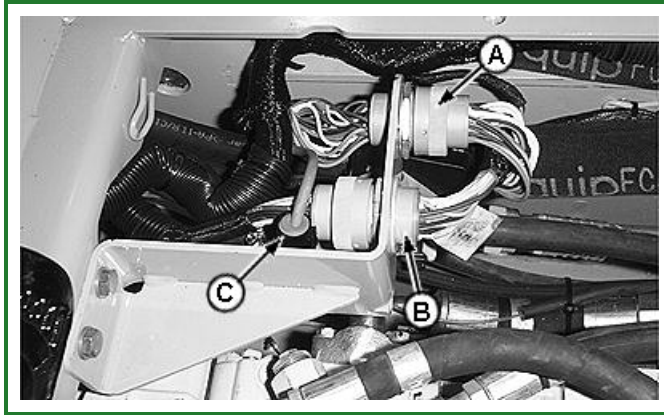

T116814B-UN: Main Wiring Harness Connectors

LEGEND:

- A - Transmission Main Wiring Harness Connector
- B - Engine Main Wiring Harness Connector
- C - Cable

Connect transmission and engine main wiring harness connectors (A and B) and cable (C).

33. Install floor plate and floor mat.

34. Install molding strip to front of cab/ROPS.

35. Fill engine coolant.

Item	Measurement	Specification
Cab/ROPS		
Cooling System Capacity		11.3 L 12 qt

36. Install engine side shields and precleaner cover.

37. Install boot on fuel filler neck and install fuel cap.

38. **For Cabs Equipped With Air Conditioning System:**

Charge air conditioning system. [See Charge R134a System](#) . (Group 1830.)

Go to [Section_18:Group_1800](#)

CED, TX03399,5019-19-19990406

Slide Glass Remove and Install

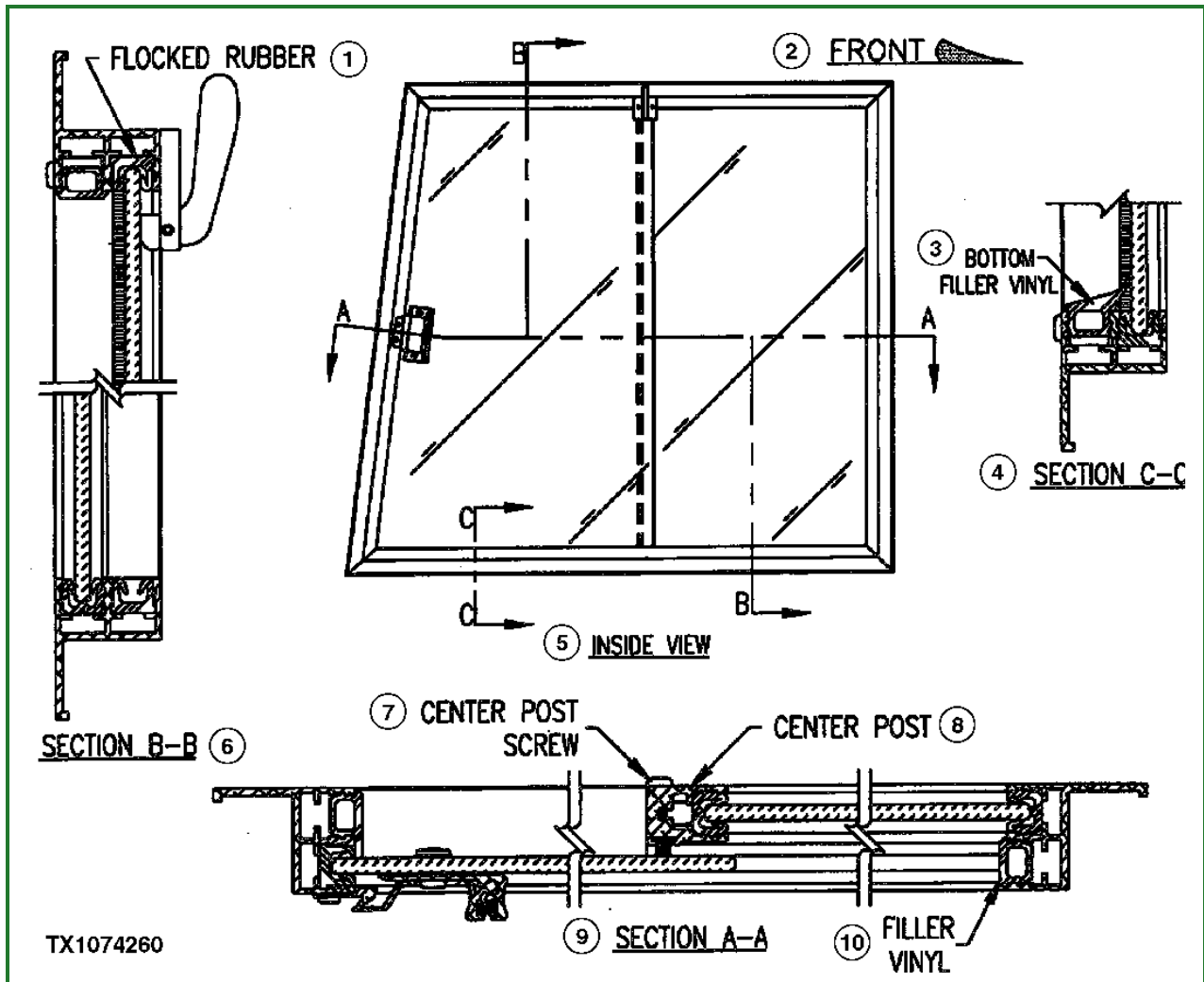

TX1074260-UN: Sliding Glass Components

LEGEND:

- 1 - Flocked Rubber
- 2 - Front
- 3 - Bottom Filler Vinyl
- 4 - Section C—C
- 5 - Inside View
- 6 - Section B—B
- 7 - Center Post Screw
- 8 - Center Post
- 9 - Section A—A
- 10 - Filler Vinyl

1. Move the slide glass to the closed position.
2. Starting at the front of the window, begin removing the flocked rubber from the channel behind the glass at the top front of the window (approximately 76 mm [3 in.] of this section of rubber extends under the glass). Slide this portion out in order to completely remove flocked rubber section.
3. Slide the glass to the front of the window and lift it up into the open channel left by removing the flocked rubber. This will allow the glass to clear the bottom channel and be removed by tilting the bottom toward the inside of the window.
4. Install new glass with the bottom of the glass tilted toward the inside of window. Lift window up into the

open channel at the top of the window until the bottom of the glass can be inserted into the bottom channel.

5. Slide the glass into the rear section of flocked rubber still in the frame and move it to the closed position.
6. Reinstall the front section of the flocked rubber by first working it in between the top of the glass and the channel until it meets up with the rear section (coating the end of the rubber with soapy water will aid in installing the flock).
7. Insert the opposite end of the rubber into the end of the channel. Push in and smooth out the middle portion.

Go to [Section_18:Group_1810](#)

CED, TX03768, 2514-19-20100322

Slide Glass Remove and Install

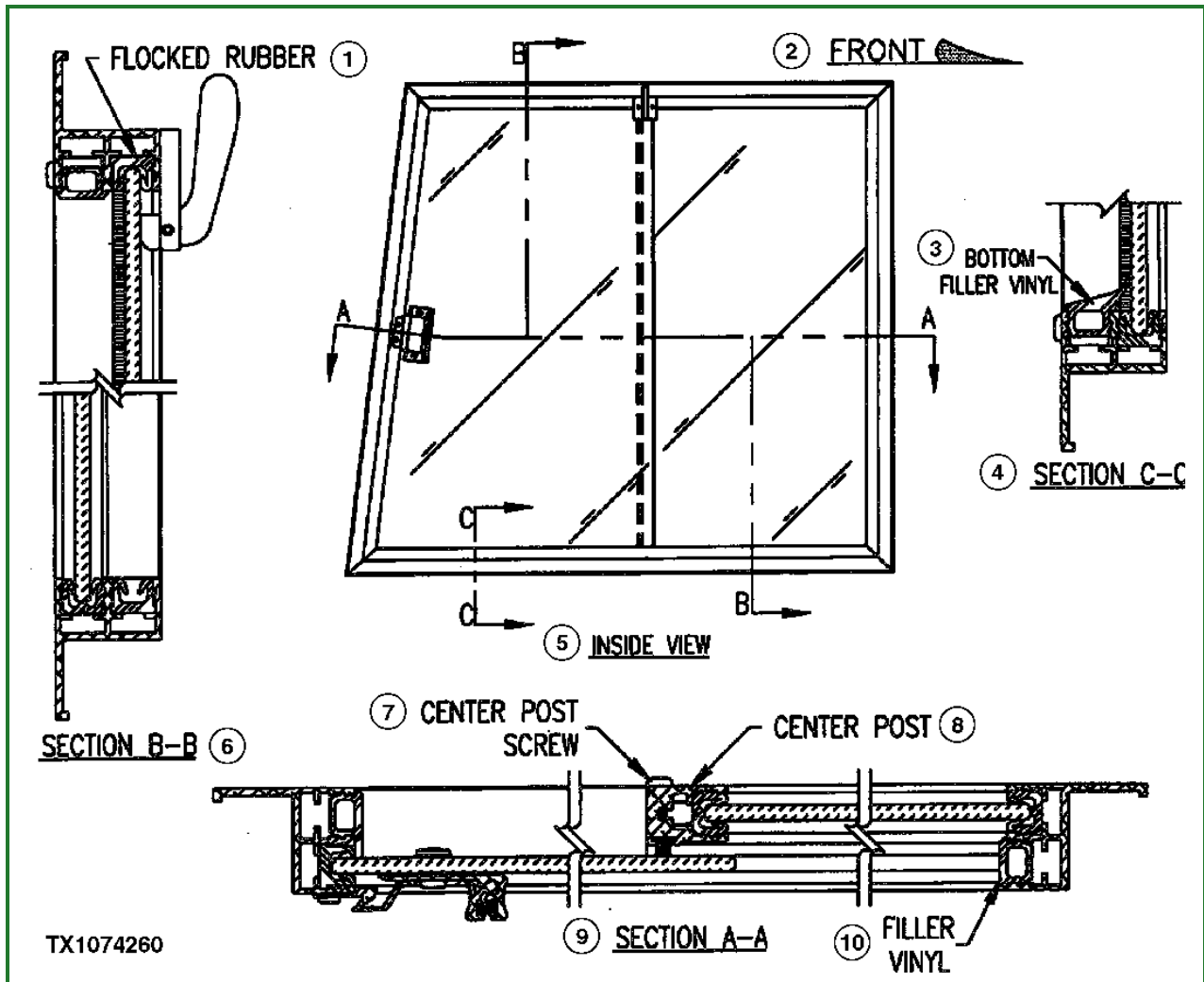

TX1074260-UN: Sliding Glass Components

LEGEND:

- 1 - Flocked Rubber
- 2 - Front
- 3 - Bottom Filler Vinyl
- 4 - Section C—C
- 5 - Inside View
- 6 - Section B—B
- 7 - Center Post Screw
- 8 - Center Post
- 9 - Section A—A
- 10 - Filler Vinyl

1. Move the slide glass to the closed position.
2. Starting at the front of the window, begin removing the flocked rubber from the channel behind the glass at the top front of the window (approximately 76 mm [3 in.] of this section of rubber extends under the glass). Slide this portion out in order to completely remove flocked rubber section.
3. Slide the glass to the front of the window and lift it up into the open channel left by removing the flocked rubber. This will allow the glass to clear the bottom channel and be removed by tilting the bottom toward the inside of the window.
4. Install new glass with the bottom of the glass tilted toward the inside of window. Lift window up into the

open channel at the top of the window until the bottom of the glass can be inserted into the bottom channel.

5. Slide the glass into the rear section of flocked rubber still in the frame and move it to the closed position.
6. Reinstall the front section of the flocked rubber by first working it in between the top of the glass and the channel until it meets up with the rear section (coating the end of the rubber with soapy water will aid in installing the flock).
7. Insert the opposite end of the rubber into the end of the channel. Push in and smooth out the middle portion.

Go to [Section_18:Group_1810](#)

CED, TX03768, 2514-19-20100322

Stationary Glass Remove and Install

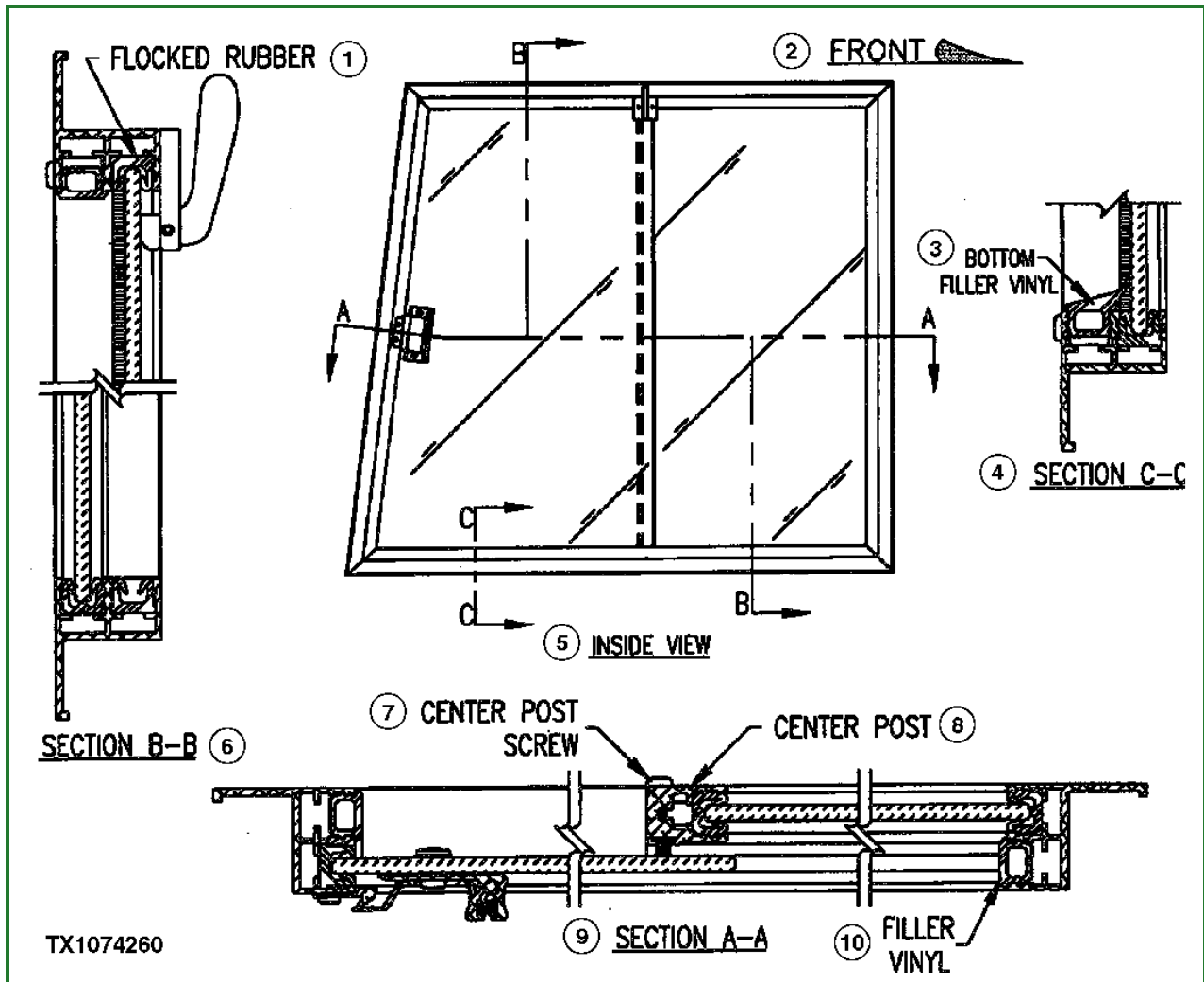

TX1074260-UN: Stationary Glass Components

LEGEND:

- 1 - Flocked Rubber
- 2 - Front
- 3 - Bottom Filler Vinyl
- 4 - Section C—C
- 5 - Inside View
- 6 - Section B—B
- 7 - Center Post Screw
- 8 - Center Post
- 9 - Section A—A
- 10 - Filler Vinyl

1. From the outside of the window and using a screwdriver, remove the filler vinyl and center post screws (the filler vinyl is held into the channel by compression only). The two center post screws are located on the outside face of the frame at both ends of the center post.
2. With the screws removed, pull back on the center post to remove it from the glass.
3. Slide the glass back until it clears the flocked rubber in the frame channel. Lift the glass up into the now open channel of the frame until the bottom of the glass can be swung clear.
4. To install new glass, tilt bottom of glass toward the outside of window, lift it up into the open channel behind the flocked rubber at the top of the window until the bottom of glass can be inserted into the

bottom channel.

5. Slide the glass into the flocked rubber until it is fully seated in the front channel.
6. Reinstall the center post assembly by tilting it until the milled ends can be inserted into the channel behind the glass and push it on to the glass. (The screw holes in the frame will align with the holes in the center post when stationary glass and center post have been properly installed.)
7. Fasten the center post screws and push filler vinyls back into the channels. Press vinyl in at both ends and then the middle (vinyls may appear to be too long, but is important not to cut them.)

Go to [Section_18:Group_1810](#)

CED,TX03768,2515-19-20100322

Sliding Window Remove and Install

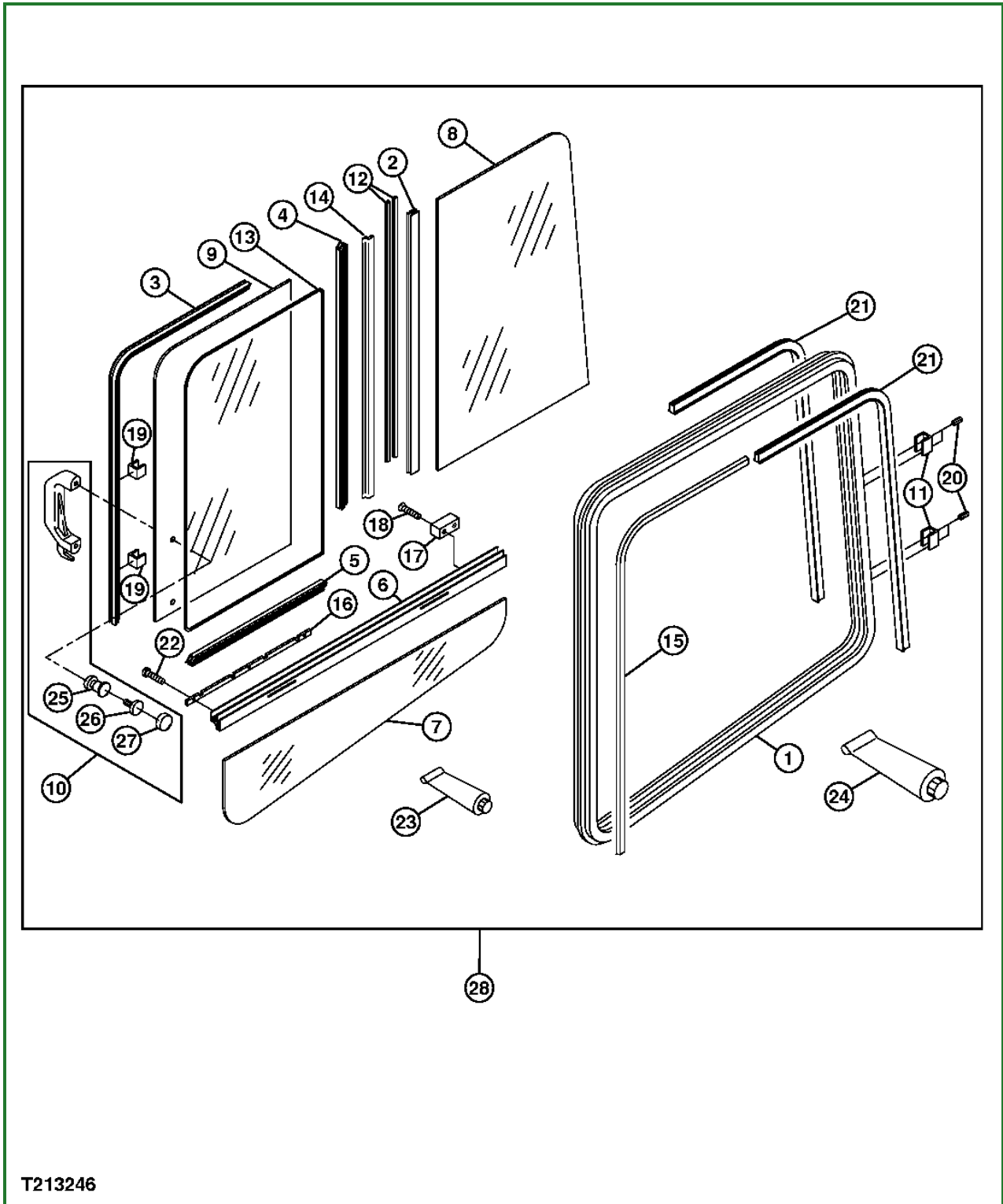

T213246

T213246-UN: Cab Sliding Side Window

LEGEND:

- 1 - Frame
- 2 - Guard
- 3 - Frame
- 4 - Frame
- 5 - Frame
- 6 - Guide
- 7 - Windowpane, Fixed
- 8 - Windowpane, Fixed

- 9 - Windowpane, Sliding
- 10 - Handle
- 11 - Sheet (2 used)
- 12 - Brush (2 used)
- 13 - Isolator (3 used)
- 14 - Isolator
- 15 - Isolator
- 16 - Rail
- 17 - Stop
- 18 - Screw (2 used)
- 19 - Guide (7 used)
- 20 - Set Screw (3 used)
- 21 - Isolator (3 used)
- 22 - Screw (3 used)
- 23 - Adhesive
- 24 - Liquid Gasket
- 25 - Sleeve (2 used)
- 26 - Screw (2 used)
- 27 - Cover (2 used)
- 28 - Windowpane (complete)

[Go to Section_18:Group_1810](#)

CED,TX14826,12085-19-19990817

Front Window Wiper Remove and Install

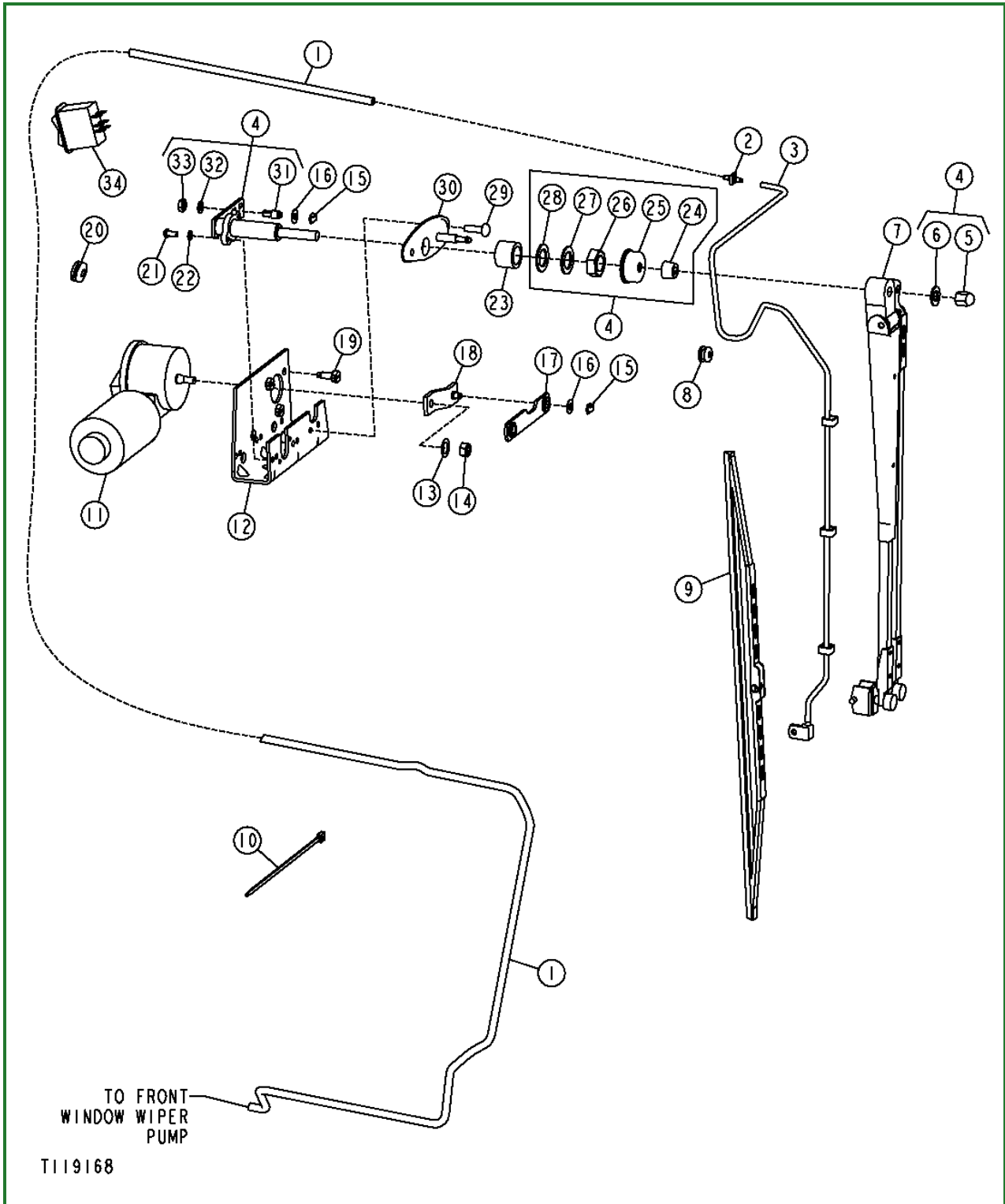

T119168-UN: Front Window Wiper

LEGEND:

- 1 - Hose
- 2 - Reducer
- 3 - Hose
- 4 - Shaft Assembly
- 5 - Nut
- 6 - Lock Washer
- 7 - Wiper Arm
- 8 - Grommet

- 9 - Wiper Blade
- 10 - Tie Band (As Required)
- 11 - Wiper Motor
- 12 - Bracket
- 13 - Washer
- 14 - Lock Nut
- 15 - Clip (2 used)
- 16 - Washer (2 used)
- 17 - Link Assembly
- 18 - Arm
- 19 - Screw (3 used)
- 20 - Grommet (3 used)
- 21 - Screw (2 used)
- 22 - Washer (2 used)
- 23 - Bushing
- 24 - Nut
- 25 - Cap
- 26 - Nut
- 27 - Washer
- 28 - Washer
- 29 - Screw (2 used)
- 30 - Pivot Plate
- 31 - Pin
- 32 - Washer
- 33 - Jam Nut
- 34 - Switch

Go to [Section_18:Group_1810](#)

CED,OUTX547,211-19-19981022

Door Window Wipers Remove and Install

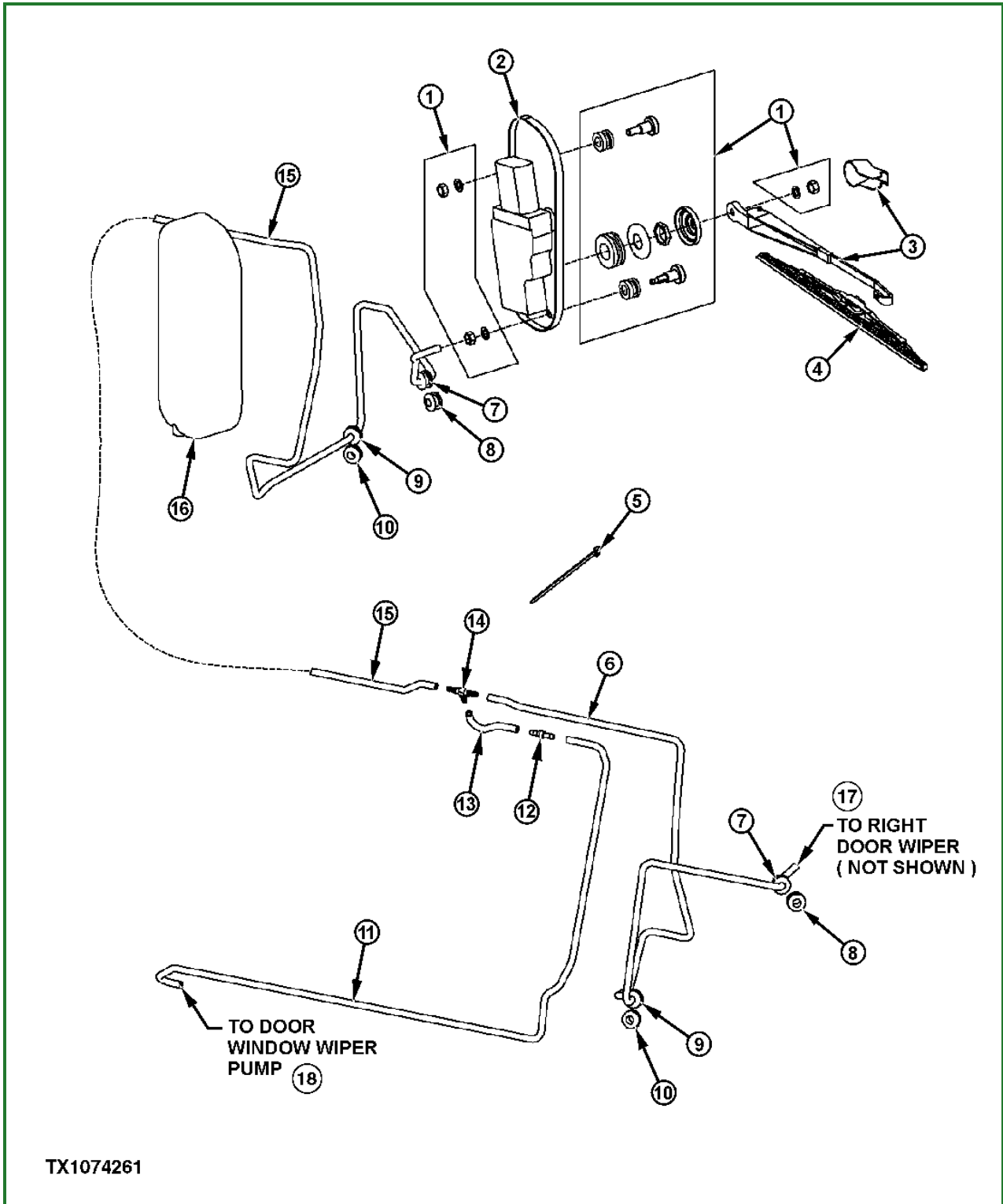

TX1074261-UN: Door Window Wiper (left shown)

LEGEND:

- 1 - Screw and Washer Kit
- 2 - Wiper Motor (left shown)
- 3 - Wiper Arm (2 used)
- 4 - Wiper Blade (2 used)
- 5 - Tie Band (as required)
- 6 - Hose
- 7 - Grommet (2 used)
- 8 - Grommet (2 used)

- 9 - Grommet (2 used)
- 10 - Windowpane Grommet
- 11 - Hose
- 12 - Valve
- 13 - Hose
- 14 - Tee Fitting
- 15 - Hose
- 16 - Wiper Cover
- 17 - To Right Door Wiper (not shown)
- 18 - To Door Window Wiper Pump

Go to [Section_18:Group_1810](#)

CED,TX03399,2366-19-20100322

Rear Window Wiper Remove and Install

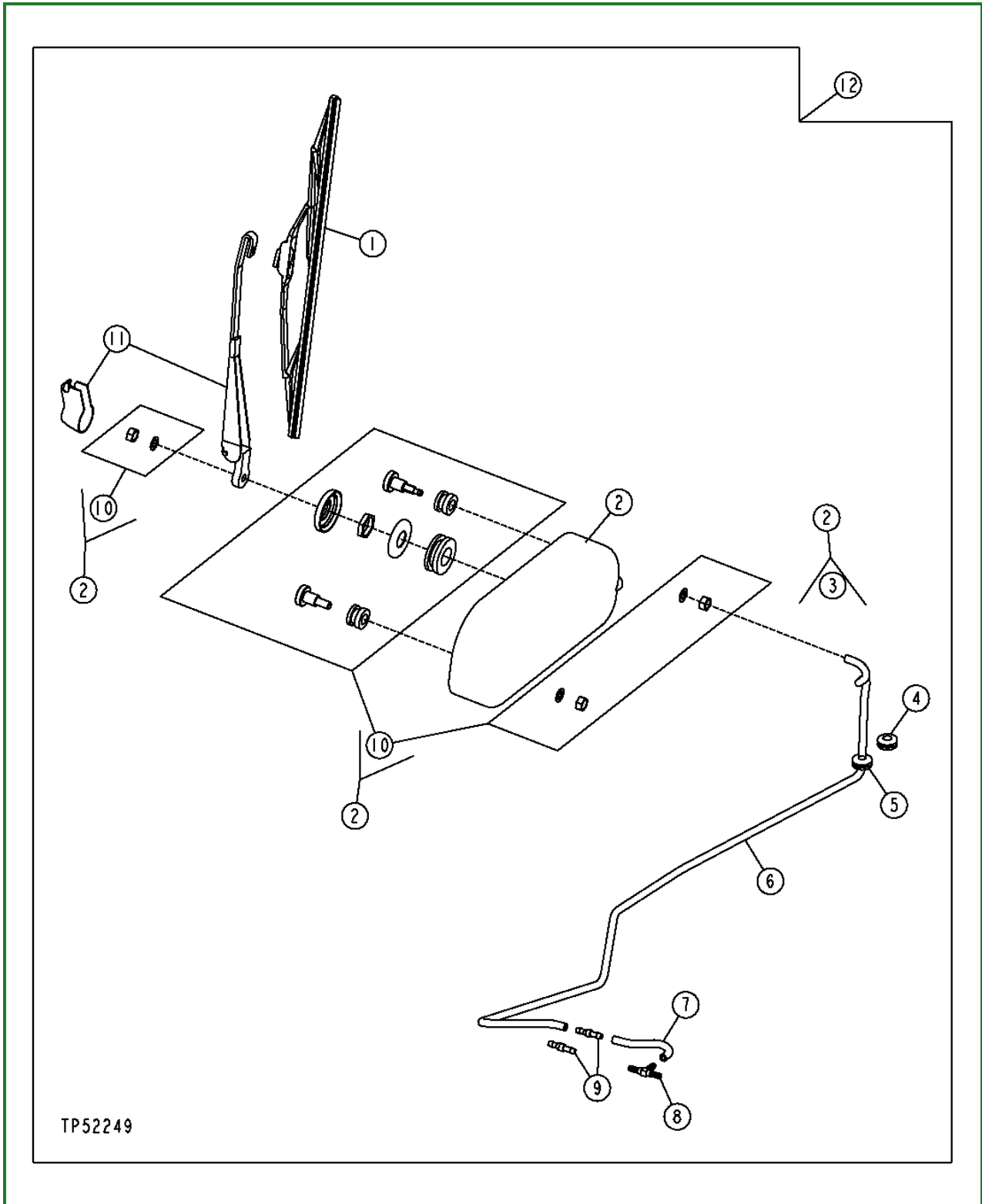

TP52249-UN: Rear Window Wiper Remove and Install

LEGEND:

- 1 - Wiper Blade
- 2 - Wiper Motor
- 3 - Cover
- 4 - Grommet
- 5 - Grommet
- 6 - Hose
- 7 - Hose
- 8 - Tee Fitting

9 - Flow Control Valve

10 - Hardware

11 - Wiper Arm

Go to [Section_18:Group_1810](#)

MF82180,00001D9-19-20040506

Window Washer Pumps Remove and Install

1.

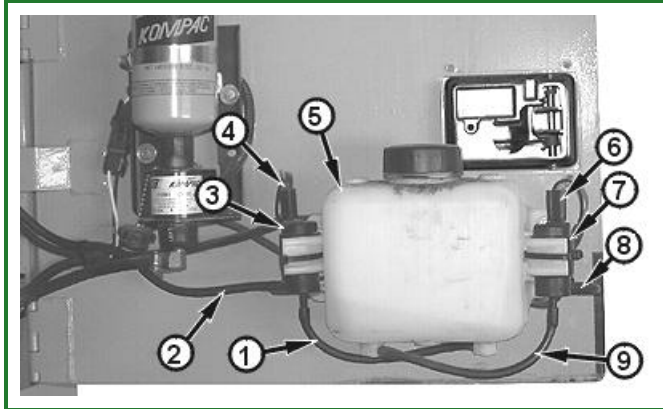

T121000B-UN: Window Washer Reservoir, Pumps, and Hoses

LEGEND:

- 1 - Hose (Window Washer Reservoir to Front/Rear Window Washer Pump Inlet)
- 2 - Hose (Washer Pump Outlet-to-Front/Rear Windows)
- 3 - Front/Rear Window Washer Pump
- 4 - Front/Rear Window Washer Pump Harness
- 5 - Window Washer Reservoir
- 6 - Left/Right Door Window Washer Pump Harness
- 7 - Left/Right Door Window Washer Pump
- 8 - Hose (Washer Pump Outlet-to-Right/Left Door Windows)
- 9 - Hose (Window Washer Reservoir to Left/Right Door Window Washer Pump Inlet)

Drain window washer reservoir (5).

2. Disconnect window washer pump inlet (1) and outlet hose (2).
3. Disconnect window washer pump harness (6).
4. Remove window washer pump (3).
5. Install window washer pump.
6. Connect window washer pump inlet and outlet hoses.
7. Connect window washer pump harness.
8. Fill window washer reservoir (5).

Go to [Section_18:Group_1810](#)

CED,OUO1066,302-19-20010323

Standard Seat Remove and Install (Old)

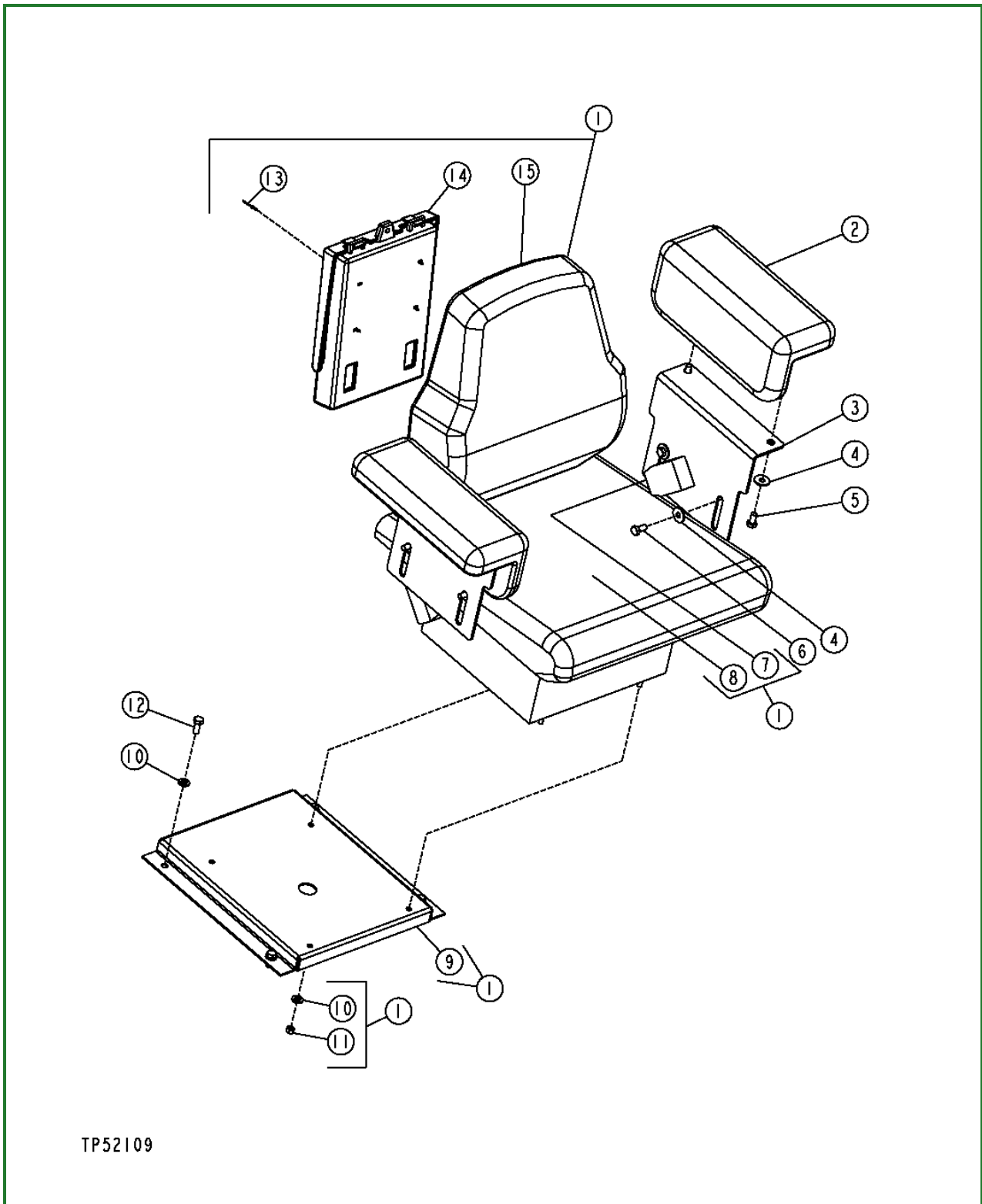

TP52109

TP52109-UN: Standard Seat Suspension

LEGEND:

- 1 - Standard Seat Suspension Assembly
- 2 - Armrest (2 used)
- 3 - Armrest Bracket (2 used)
- 4 - Washer (8 used)
- 5 - Cap Screw (4 used)
- 6 - Cap Screw (4 used)
- 7 - Seat Belt
- 8 - Seat Pad

- 9 - Bracket
- 10 - Washer (8 used)
- 11 - Lock Nut (4 used)
- 12 - Cap Screw (4 used)
- 13 - Rivet (4 used)
- 14 - Holder
- 15 - Back Pad

1.

⚠ CAUTION:

Prevent possible crushing injury from seat suspension. Use proper lifting equipment and safety precautions.

Remove parts as necessary.

2. Install parts as necessary.

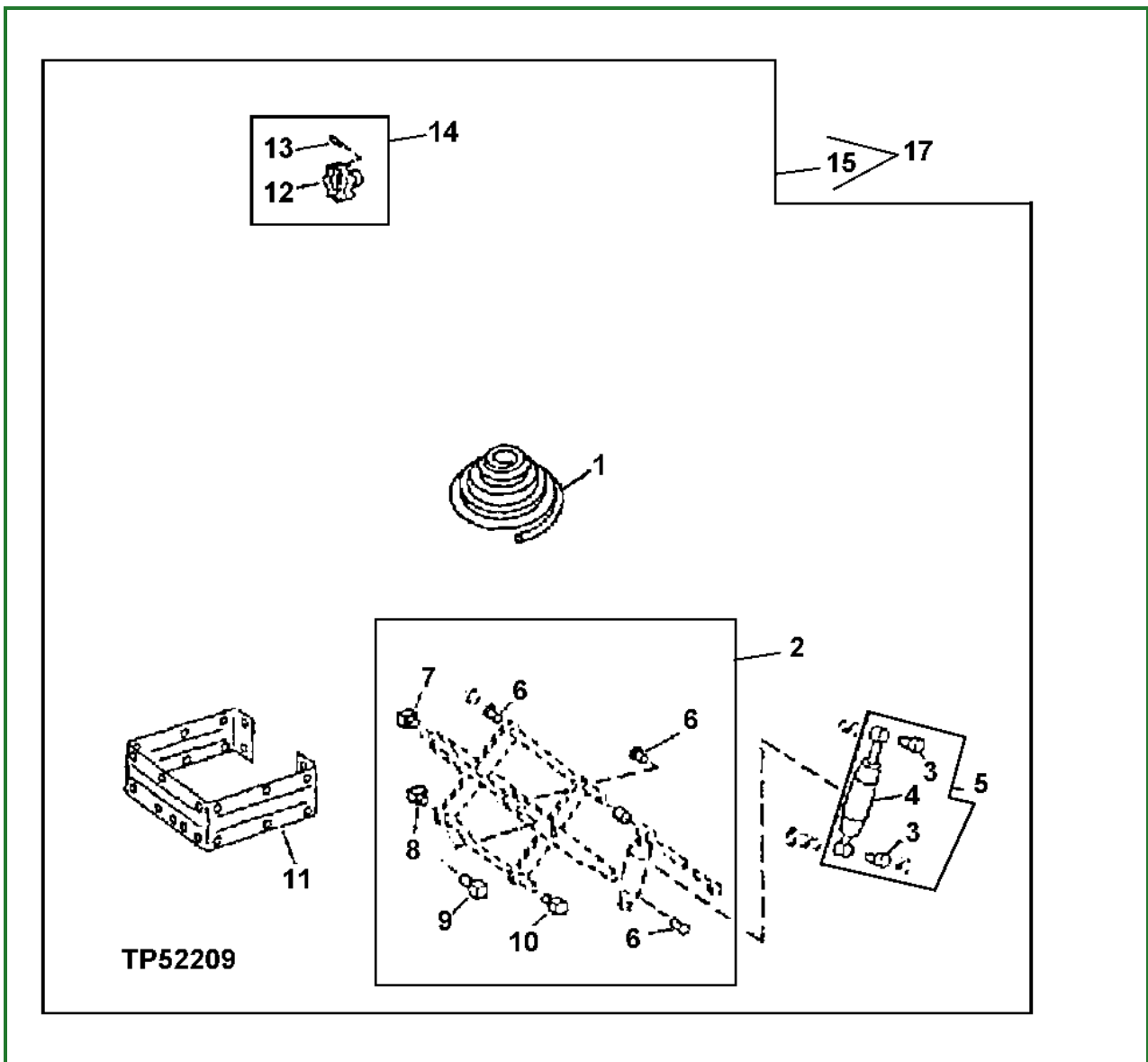

TP52209-UN: Standard Seat Suspension

LEGEND:

- 1 - Spring
- 2 - Suspension Bearing Kit

- 3 - Bushing (2 used)
- 4 - Absorber
- 5 - Shock Absorber Kit
- 6 - Bushing (4 used)
- 7 - Bar
- 8 - Bar
- 9 - Bar
- 10 - Bar
- 11 - Boot with Plugs
- 12 - Knob
- 13 - Spring Pin
- 14 - Height and Weight Adjustable Knob Kit
- 15 - Guard Suspension Assembly
- 17 - Standard Seat Suspension Assembly

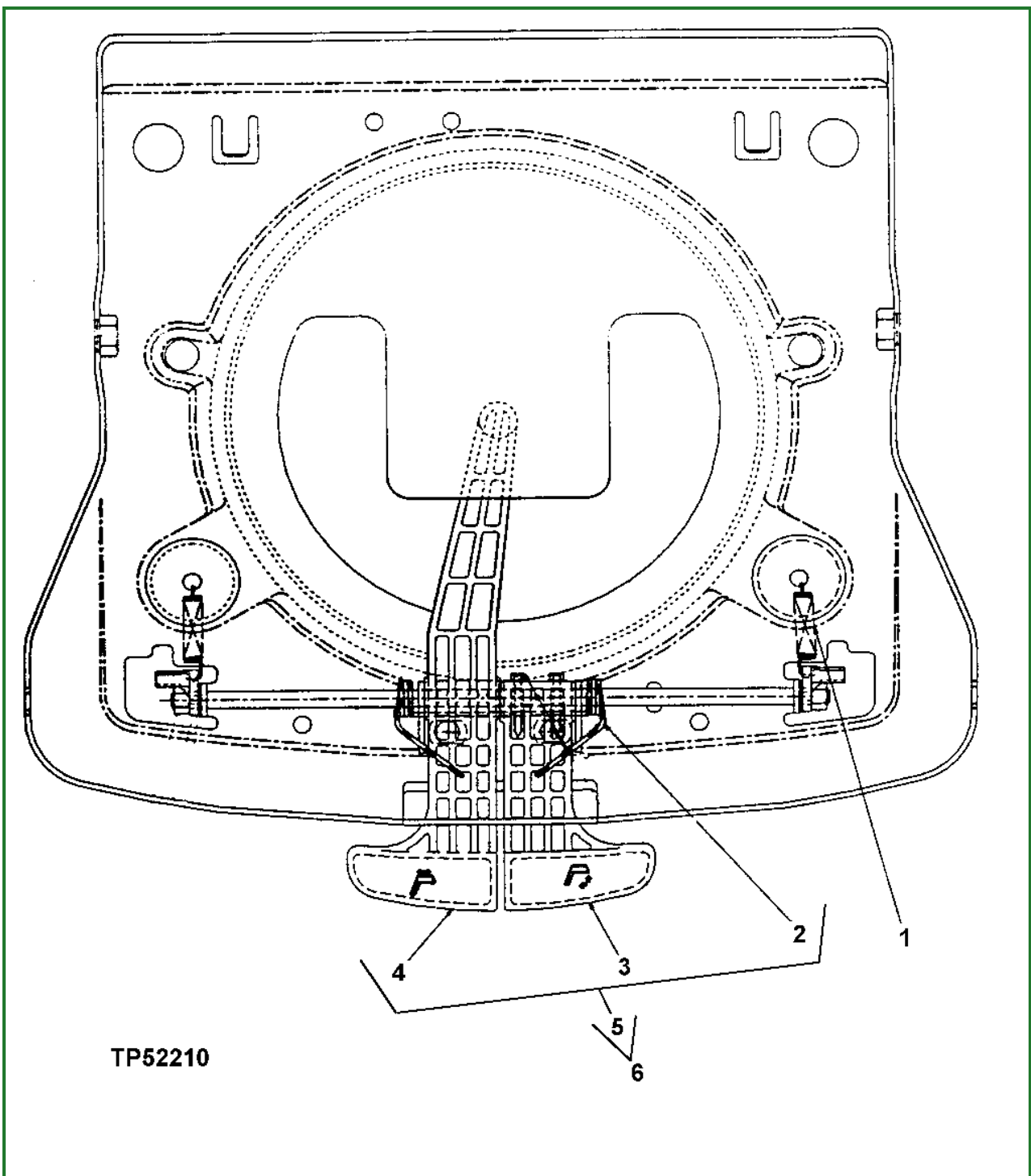

TP52210-UN: Seat Slide and Tilt Control (Standard or Deluxe Seat)

LEGEND:

- 1 - Spring (2 used)
- 2 - Torsion Spring
- 3 - Seat Tilt Control
- 4 - Fore-Aft Control
- 5 - Slide/Seat Tilt Control Kit
- 6 - Standard or Deluxe Seat Suspension Assembly

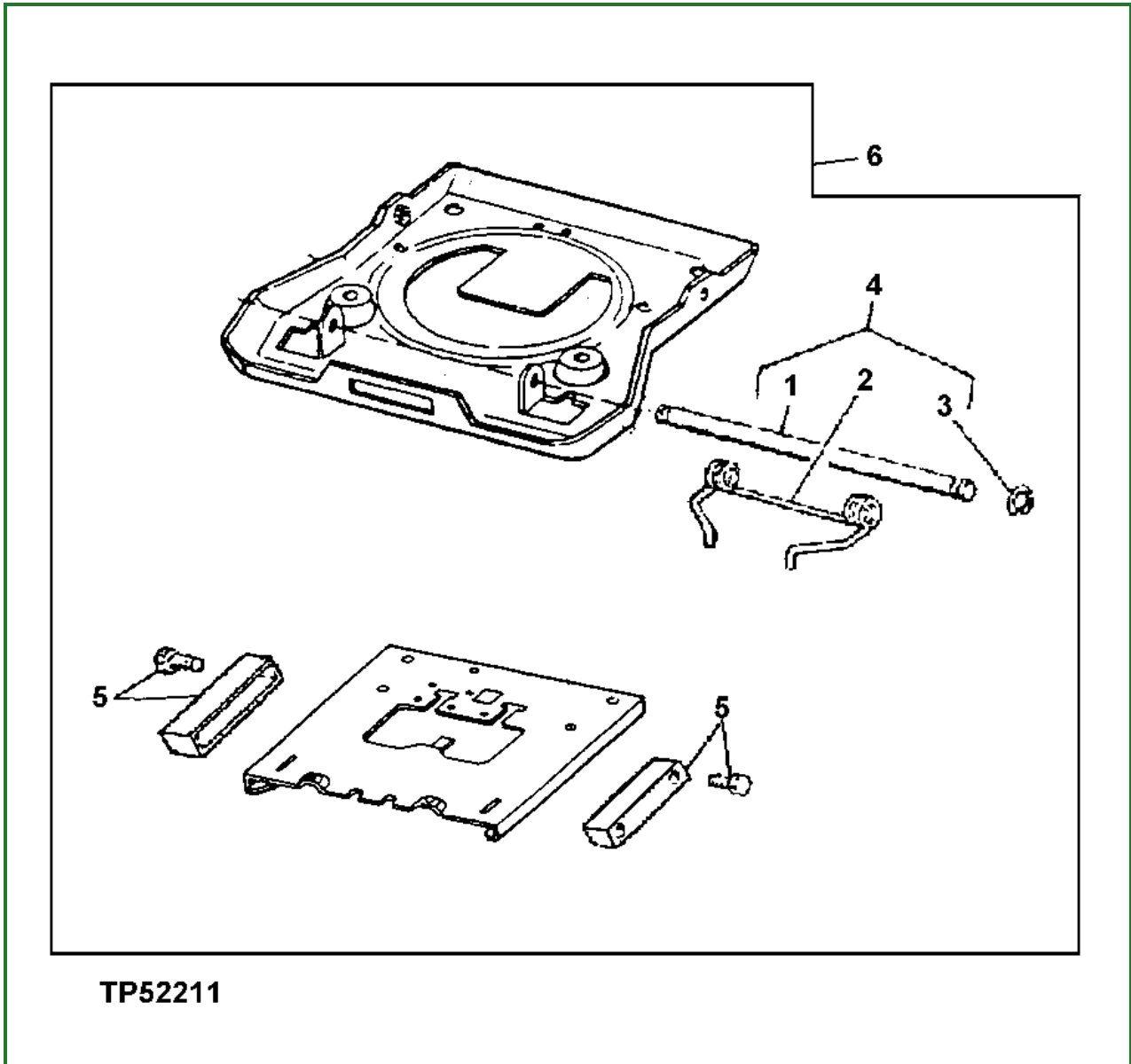

TP52211-UN: Seat Slide Spring (Standard or Deluxe Seat)

LEGEND:

- 1 - Shaft
- 2 - Spring
- 3 - Snap Ring
- 4 - Slide Latch Spring Kit
- 5 - Slide Puck Kit
- 6 - Standard or Deluxe Seat Suspension Assembly

Go to [Section_18:Group_1821](#)

CED,OUTX547,168-19-20060317

Standard Seat Remove and Install (Old)

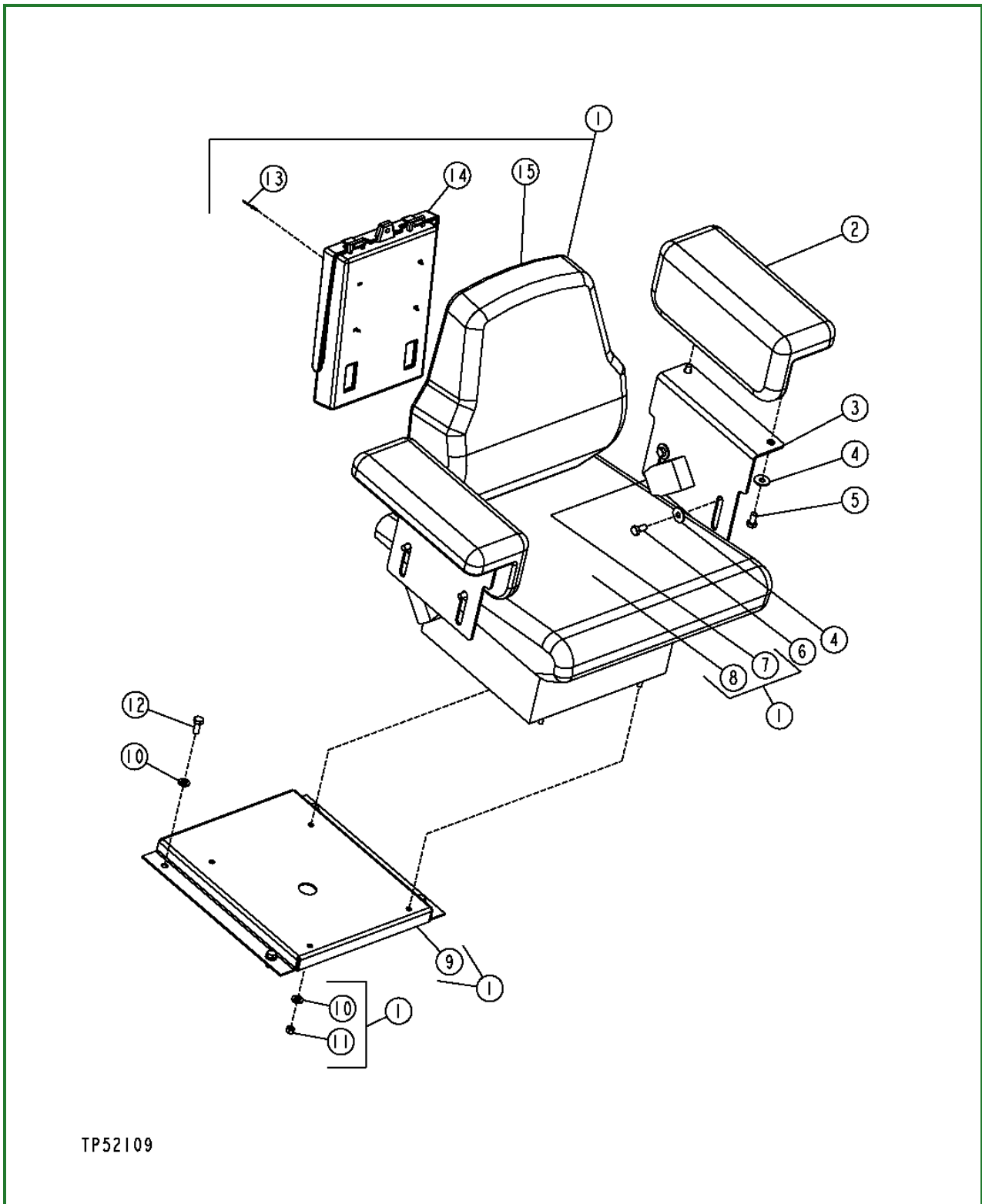

TP52109-UN: Standard Seat Suspension

LEGEND:

- 1 - Standard Seat Suspension Assembly
- 2 - Armrest (2 used)
- 3 - Armrest Bracket (2 used)
- 4 - Washer (8 used)
- 5 - Cap Screw (4 used)
- 6 - Cap Screw (4 used)
- 7 - Seat Belt
- 8 - Seat Pad

- 9 - Bracket
- 10 - Washer (8 used)
- 11 - Lock Nut (4 used)
- 12 - Cap Screw (4 used)
- 13 - Rivet (4 used)
- 14 - Holder
- 15 - Back Pad

1.

⚠ CAUTION:

Prevent possible crushing injury from seat suspension. Use proper lifting equipment and safety precautions.

Remove parts as necessary.

2. Install parts as necessary.

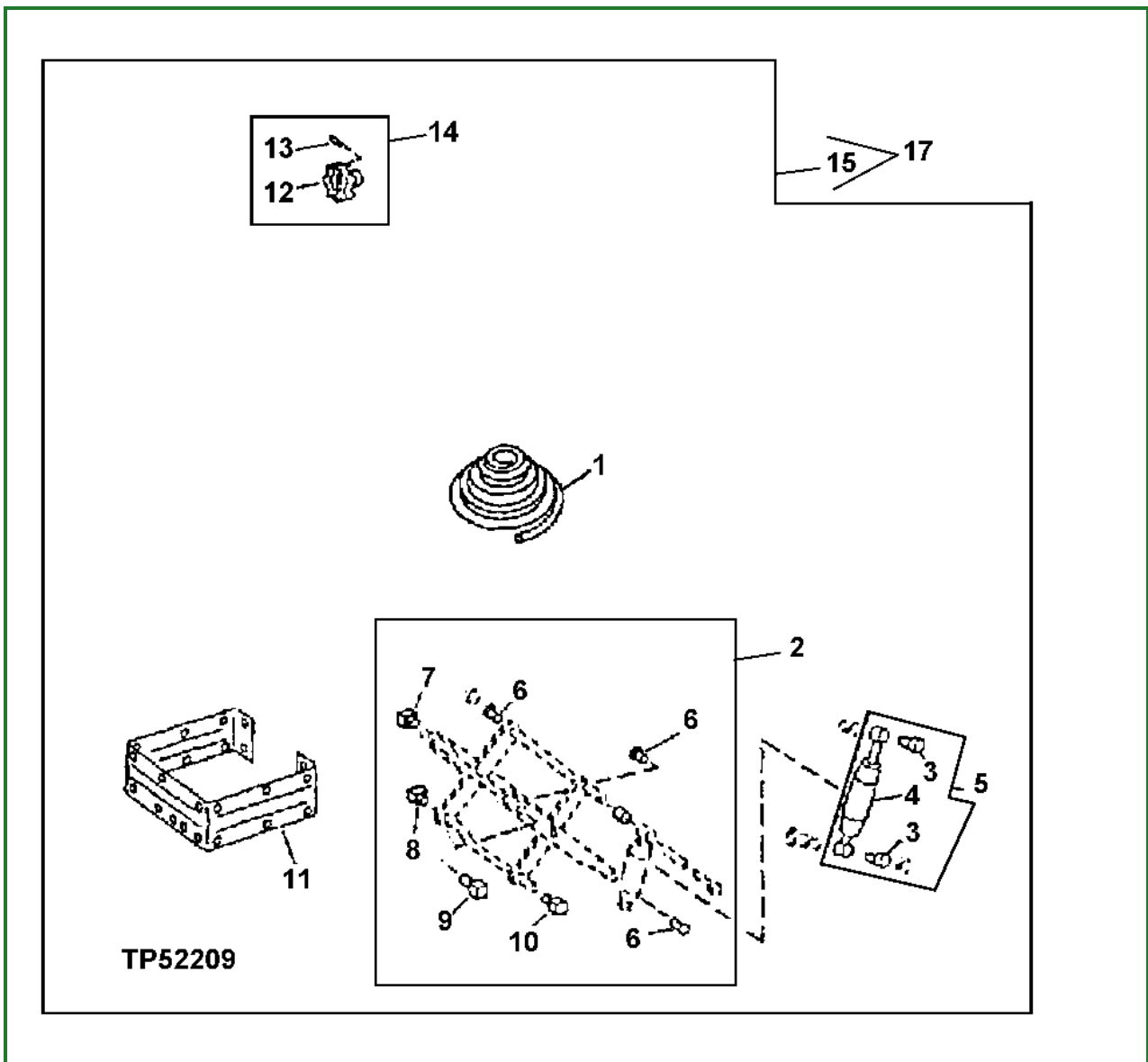

TP52209-UN: Standard Seat Suspension

LEGEND:

- 1 - Spring
- 2 - Suspension Bearing Kit

- 3 - Bushing (2 used)
- 4 - Absorber
- 5 - Shock Absorber Kit
- 6 - Bushing (4 used)
- 7 - Bar
- 8 - Bar
- 9 - Bar
- 10 - Bar
- 11 - Boot with Plugs
- 12 - Knob
- 13 - Spring Pin
- 14 - Height and Weight Adjustable Knob Kit
- 15 - Guard Suspension Assembly
- 17 - Standard Seat Suspension Assembly

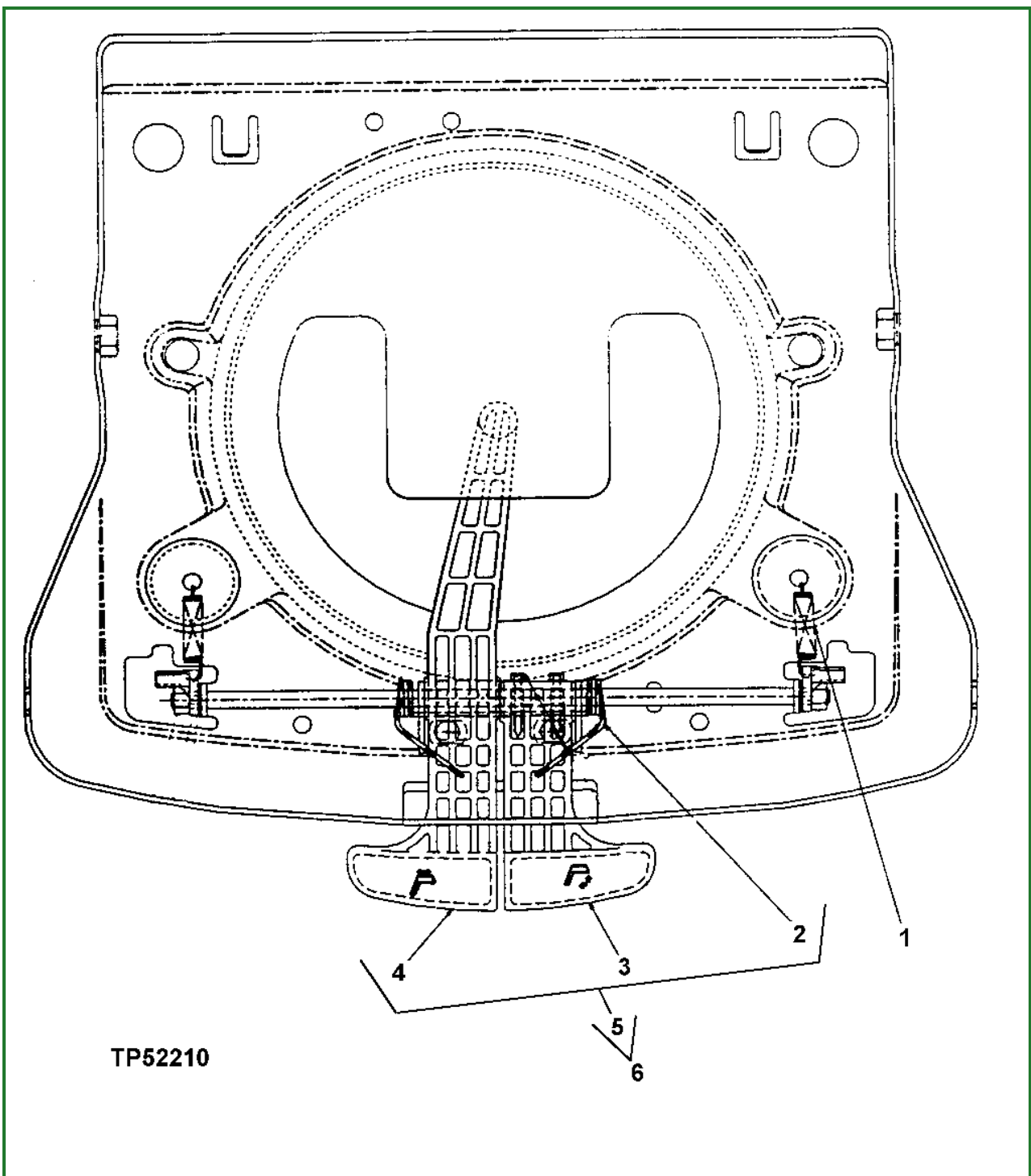

TP52210-UN: Seat Slide and Tilt Control (Standard or Deluxe Seat)

LEGEND:

- 1 - Spring (2 used)
- 2 - Torsion Spring
- 3 - Seat Tilt Control
- 4 - Fore-Aft Control
- 5 - Slide/Seat Tilt Control Kit
- 6 - Standard or Deluxe Seat Suspension Assembly

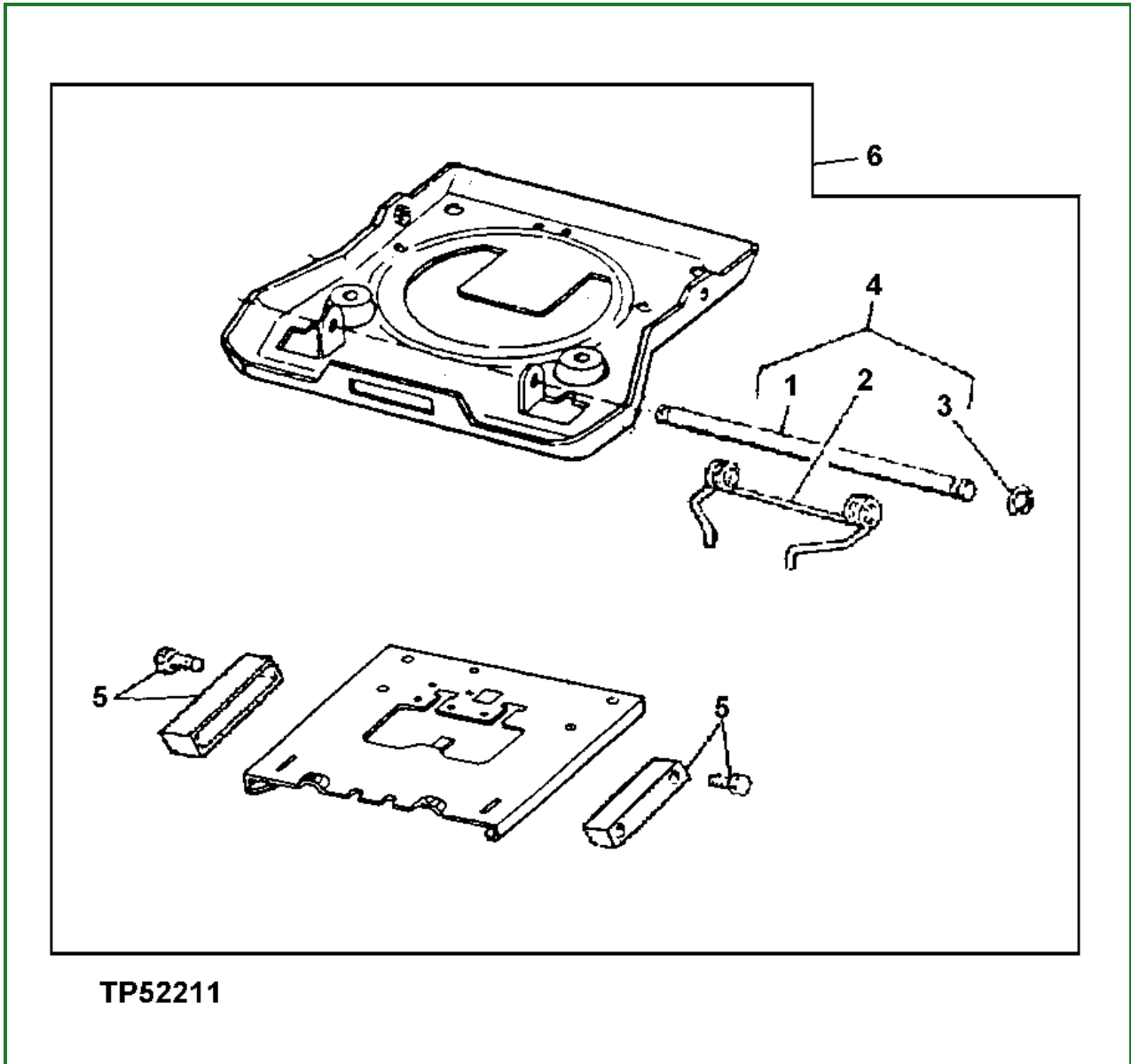

TP52211-UN: Seat Slide Spring (Standard or Deluxe Seat)

LEGEND:

- 1 - Shaft
- 2 - Spring
- 3 - Snap Ring
- 4 - Slide Latch Spring Kit
- 5 - Slide Puck Kit
- 6 - Standard or Deluxe Seat Suspension Assembly

Go to [Section_18:Group_1821](#)

CED,OUTX547,168-19-20060317

Deluxe Seat Remove and Install

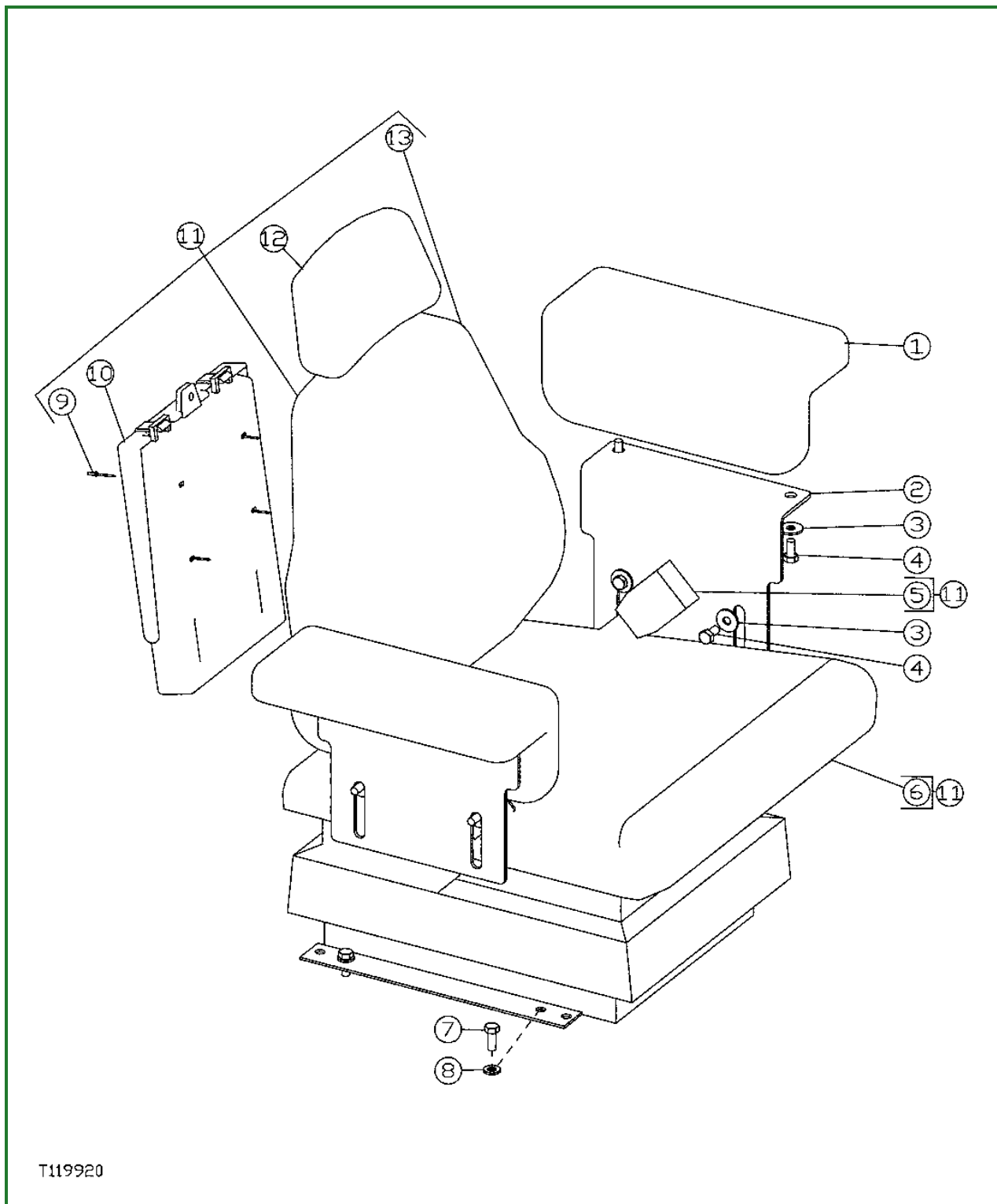

T119920-UN: Deluxe Seat Suspension

LEGEND:

- 1 - Armrest (2 used)
- 2 - Armrest Bracket (2 used)
- 3 - Washer (8 used)
- 4 - Cap Screw (8 used)
- 5 - Seat Belt
- 6 - Seat Pad
- 7 - Cap Screw (4 used)
- 8 - Washer (4 used)

- 9 - Rivet (As Required)
- 10 - Holder
- 11 - Deluxe Seat Suspension Assembly
- 12 - Cushion
- 13 - Back Pad

1.

 **CAUTION:**

Prevent possible crushing injury from seat suspension. Use proper lifting equipment and safety precautions.

Remove parts as necessary.

2. Install parts as necessary.

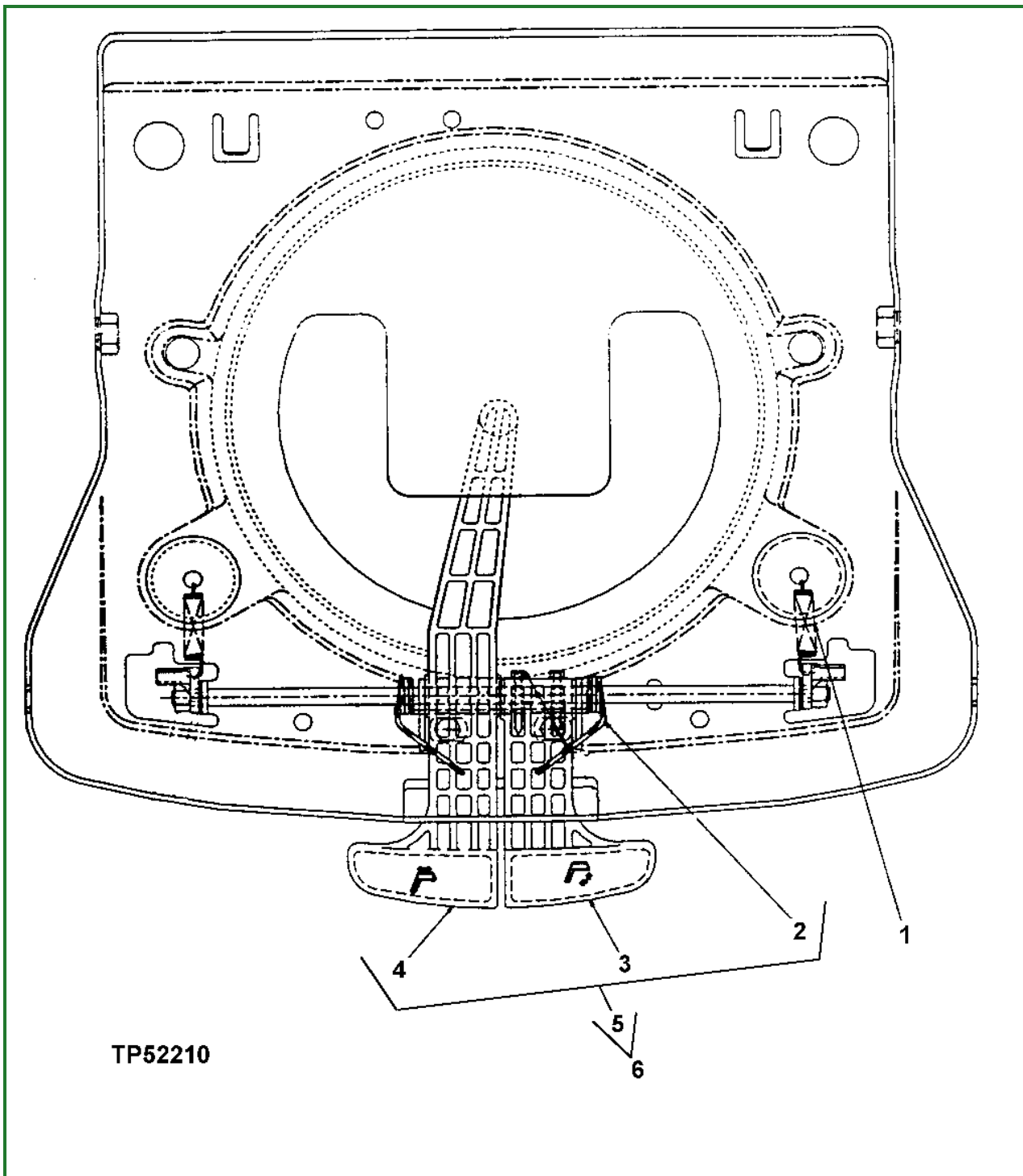

TP52210

TP52210-UN: Seat Slide and Tilt Control (Standard or Deluxe Seat)

LEGEND:

- 1 - Spring (2 used)
- 2 - Torsion Spring
- 3 - Seat Tilt Control
- 4 - Fore-Aft Control
- 5 - Slide/Seat Tilt Control Kit
- 6 - Standard or Deluxe Seat Suspension Assembly

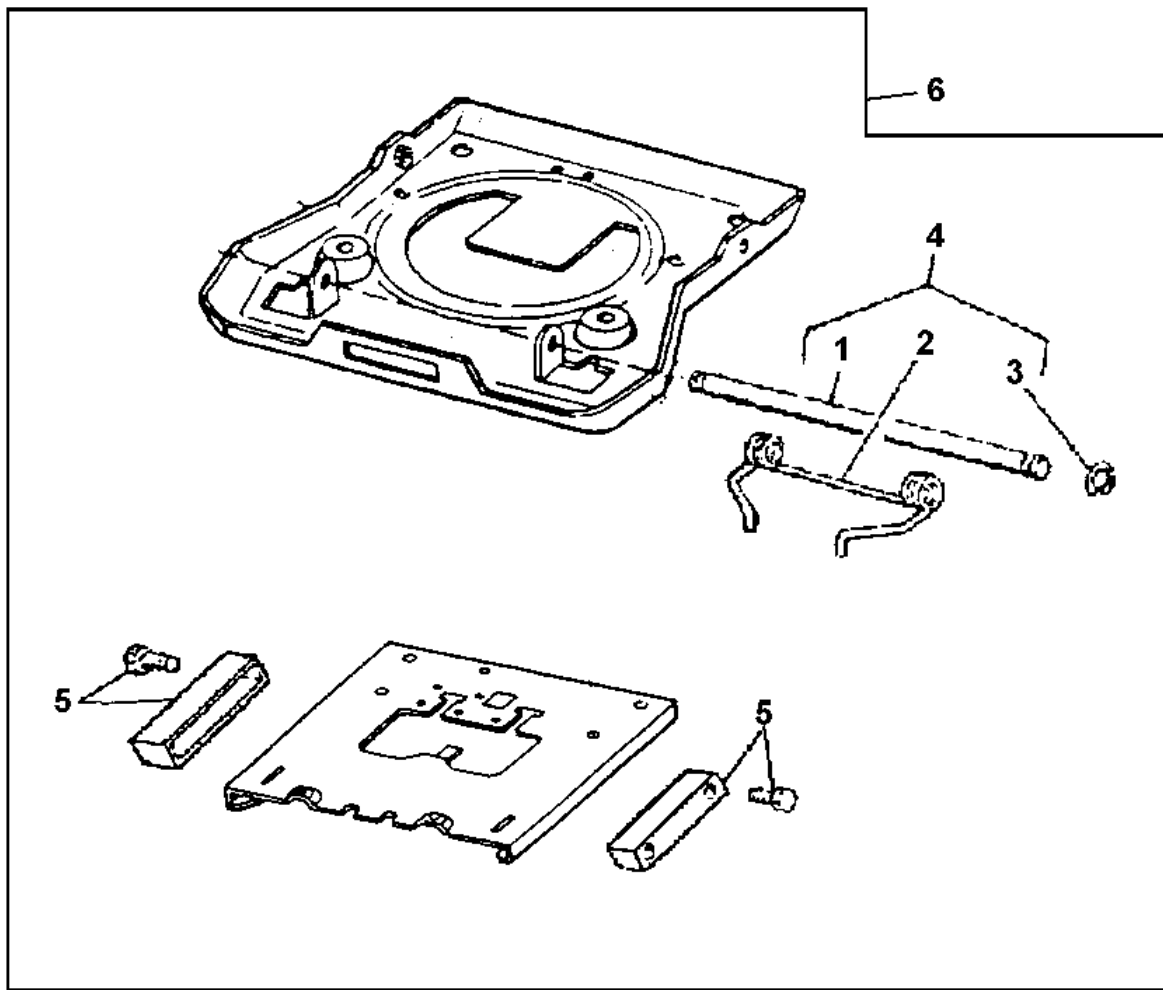

TP52211

TP52211-UN: Seat Slide Spring (Standard or Deluxe Seat)

LEGEND:

- 1 - Shaft
- 2 - Spring
- 3 - Snap Ring
- 4 - Slide Latch Spring Kit
- 5 - Slide Puck Kit
- 6 - Standard or Deluxe Seat Suspension Assembly

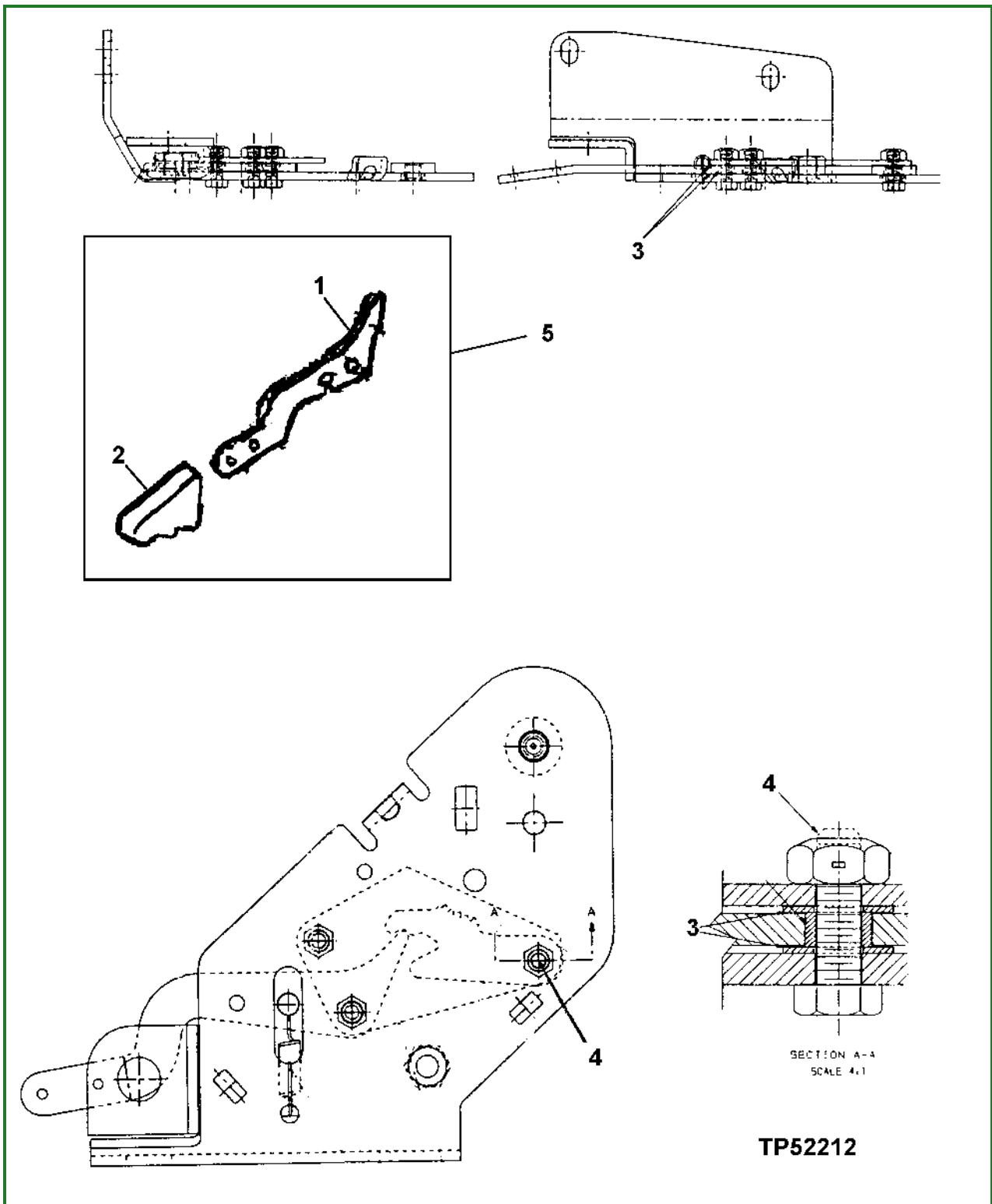

TP52212-UN: Recliner/Lumbar Knob Kit (Deluxe Seat)

LEGEND:

- 1 - Recliner Kit
- 2 - Recliner Kit and Screw
- 3 - Washer (6 used)
- 4 - Cap Screw (3 used)
- 5 - Deluxe Seat Suspension Assembly

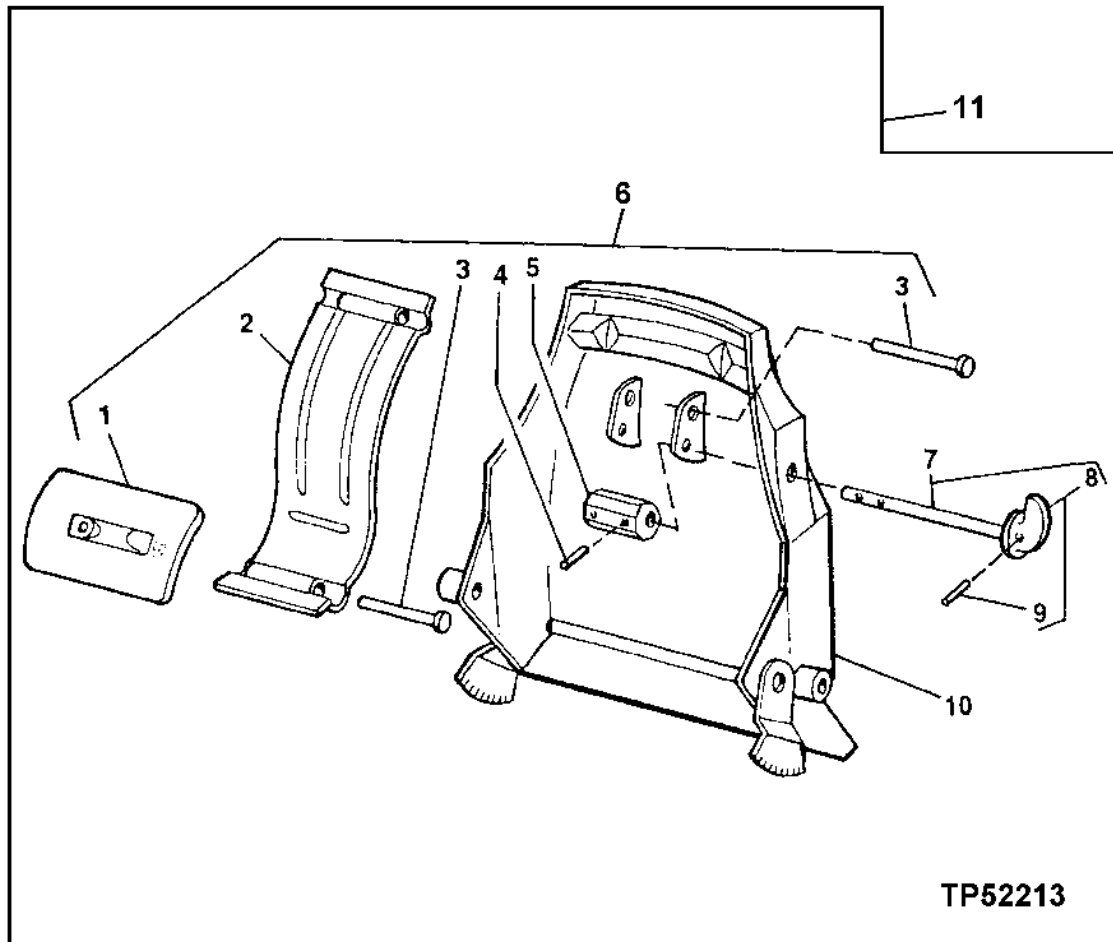

TP52213-UN: Lumbar Support and Control (Deluxe Seat)

LEGEND:

- 1 - Isolator
- 2 - Support
- 3 - Pin (2 used)
- 4 - Spring Pin
- 5 - Cam
- 6 - Lumbar Kit
- 7 - Knob with Shaft
- 8 - Lumbar Knob Kit
- 9 - Spring Pin

10 - Seat Back

11 - Deluxe Seat Suspension Assembly

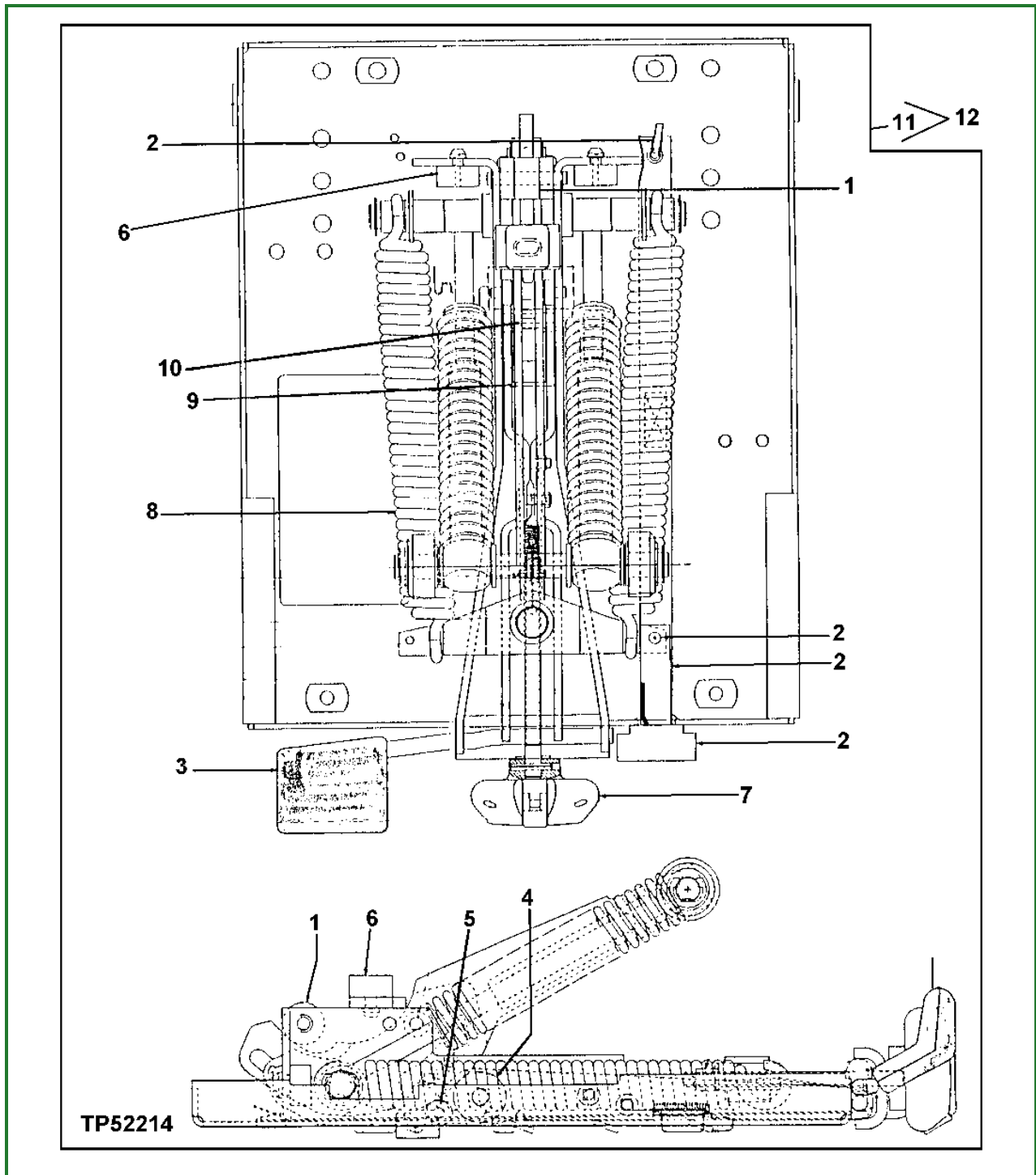

TP52214-UN: Seat Suspension Kits (Deluxe Seat)

LEGEND:

- 1 - Cam Kit—Cam Follower and Pin
- 2 - Weight Kit—Tape, Guide, Cable Tie and Pop Rivet
- 3 - Knob Kit—Height Adjust Knob Upper and Lower
- 4 - Cam Kit—Cam Follower and Pin
- 5 - Actuator Kit—Idler roller (2 used) and cam roller
- 6 - Bumper Kit—Bumpers (3 used)
- 7 - Weight Adjust Knob Kit—Knob, Fixture, Spacer, Shaft
- 8 - Spring Kit—Bushings (2 used) and Springs (2 used)
- 9 - Cam Kit—Cam Follower, Pin
- 10 - Actuator Kit—Idler Roller (2 used), Cam Roller

11 - Seat Suspension Sub-Assembly

12 - Deluxe Seat Suspension

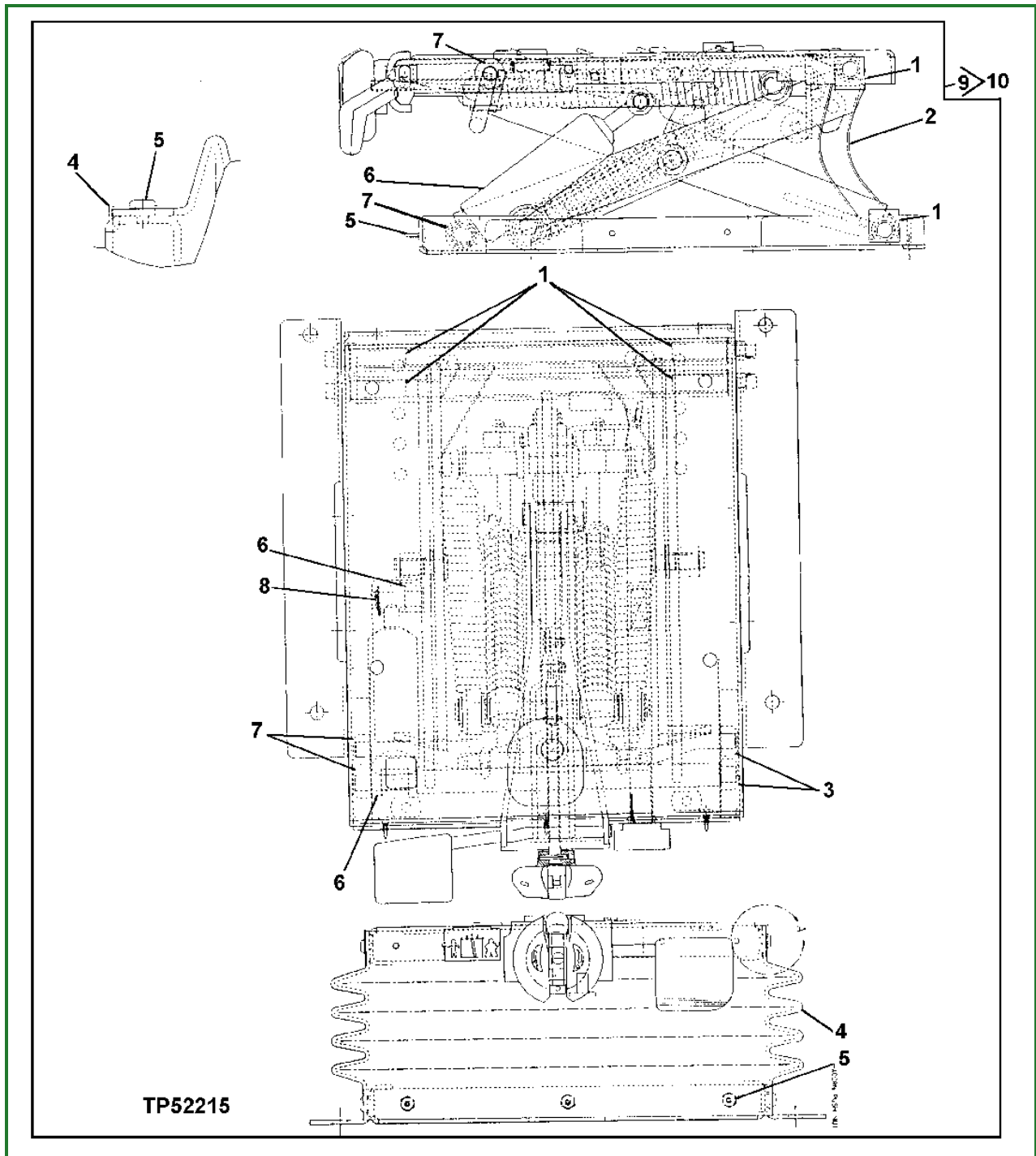

TP52215-UN: Seat Suspension Kits (Deluxe Seat)

LEGEND:

- 1 - Universal Driveshaft Kit—Bearings (4 used), Bearing Shaft Weldment (2 used)
- 2 - Tether Belt Kit—Tether Belt (2 used)
- 3 - Roller Kit—Roller (4 used)
- 4 - Boot Kit—Clip (23 used), Male Fastener (3 used), Female Fastener (3 used), Boot, Boot Retainer (2 used)
- 5 - Boot Clip Kit—Clip (23 used), Male Fastener (3 used), Female Fastener (3 used)
- 6 - Shock Kit—Push Nut, Shock, Bearing (2 used)
- 7 - Roller Kit—Roller (4 used)
- 8 - Height Adjust Kit—Spring Bushing (2 used), Spring (2 used), Retainer ring (4 used), Push Nut (2 used)
- 9 - Deluxe Seat Sub-Assembly
- 10 - Deluxe Seat Suspension

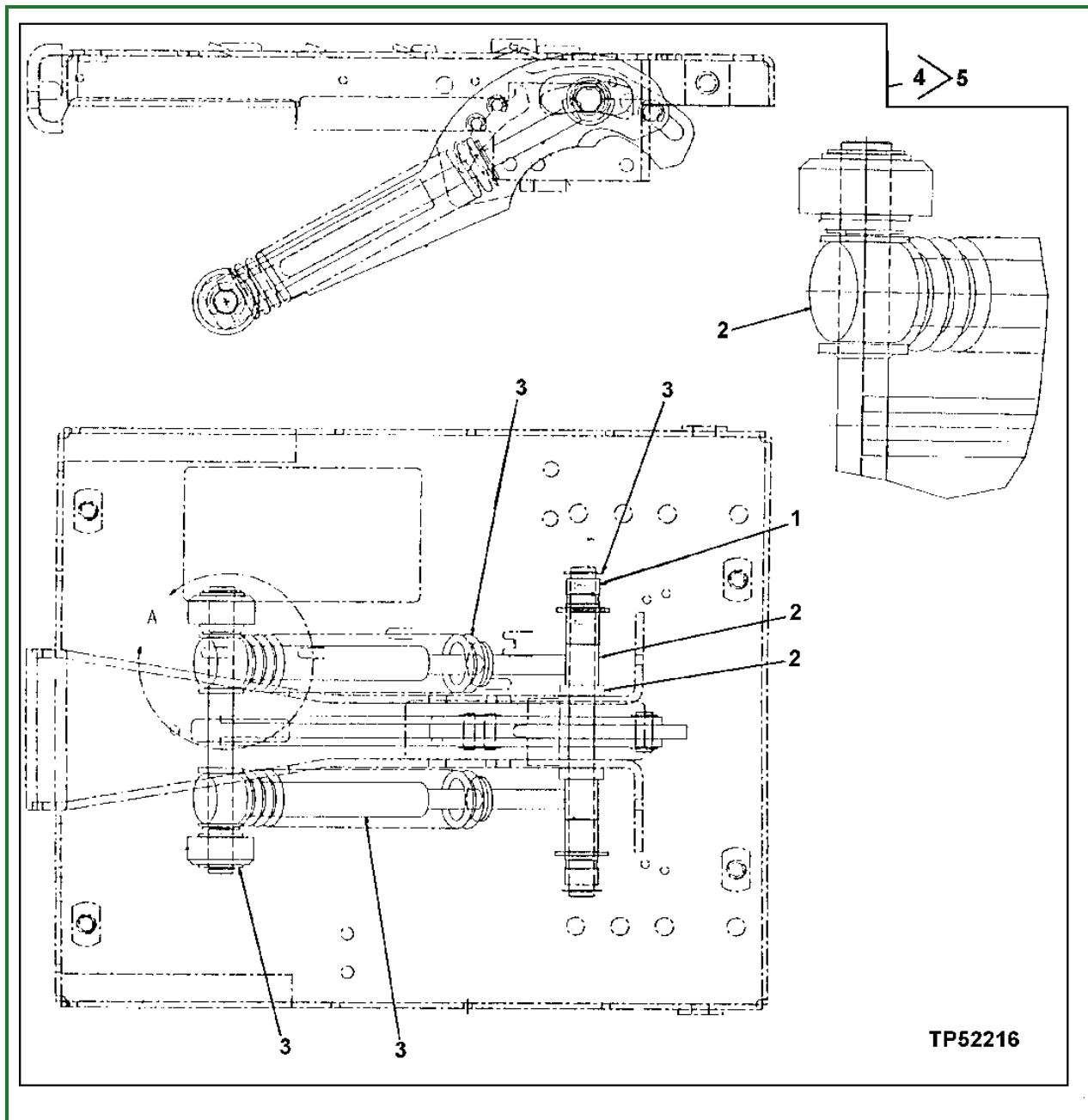

TP52216-UN: Seat Suspension Kits (Deluxe Seat)

LEGEND:

- 1 - Spring Kit—Spring Shaft Bushing (2 used), Spring (2 used)
- 2 - Spring Kit—Height Adjust Spring Rod Weldment (2 used), Spring Guide Bushing (2 used), Spring (2 used), Spacer (2 used)
- 3 - Height Adjust Kit—Bushings (4 used), Spring (4 used), Retainer Ring (4 used), Push Nut (2 used), Spacer (2 used), Spring Rod Weldment (2 used)
- 4 - Deluxe Sub-Assembly
- 5 - Deluxe Suspension Seat

Go to [Section_18:Group_1821](#)

CED,OUO1066,274-19-20090729

Air Suspension Seat Remove and Install

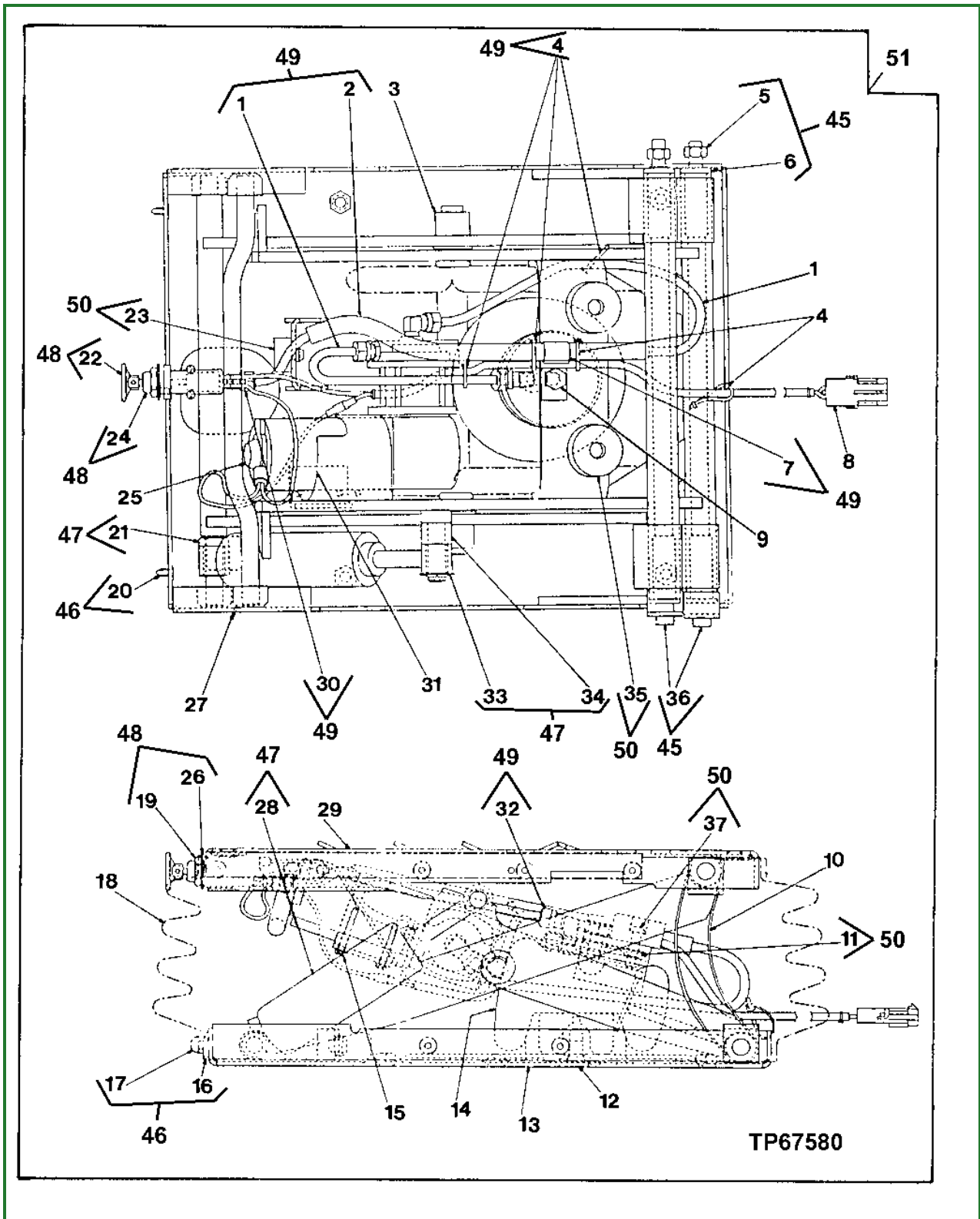

TP67580-UN: Seat Suspension Kits (deluxe air seat)

LEGEND:

- 1 - Line (3 used)
- 2 - Air Line Tube
- 3 - Arm
- 4 - Tie Band (5 used)
- 5 - Lock Nut (2 used)
- 6 - Suspension Shaft (2 used)
- 7 - Clip

- 8 - Wire Harness
- 9 - Cap Screw
- 10 - Tether Belt Kit
- 11 - Lock Nut
- 12 - Screw
- 13 - Housing
- 14 - Spring
- 15 - Screw (2 used)
- 16 - Clip (23 used)
- 17 - Push Nut (3 used)
- 18 - Boot Kit
- 19 - Nut
- 20 - Clip (3 used)
- 21 - Bearing
- 22 - Knob
- 23 - Bumper
- 24 - Control Valve
- 25 - Compressor
- 26 - Lock Washer
- 27 - Roller
- 28 - Absorber
- 29 - Housing
- 30 - Connector (2 used)
- 31 - Bracket
- 32 - Elbow Fitting (2 used)
- 33 - Bolt
- 34 - Bearing
- 35 - Bumper
- 36 - Bearing (2 used)
- 37 - Screw
- 45 - Universal Suspension Driveshaft
- 46 - Boot Clip
- 47 - Shock Absorber Kit
- 48 - Air Control Valve
- 49 - Air Line Fitting
- 50 - Bumper
- 51 - Seat and Air Suspension Assembly

1.

 **CAUTION:**

Prevent possible crushing injury from seat suspension. Use proper lifting equipment and safety precautions.

Remove parts as necessary.

2. Install parts as necessary.

Go to [Section_18:Group_1821](#)

CED, TX03399, 6055-19-20091204

R134a Refrigerant Cautions** CAUTION:**

DO NOT allow liquid refrigerant to contact eyes or skin. Liquid refrigerant will freeze eyes or skin on contact. Wear goggles, gloves and protective clothing.

If liquid refrigerant contacts eyes or skin, DO NOT rub the area. Splash large amounts of COOL water on affected area. Go to a physician or hospital immediately for treatment.

DO NOT allow refrigerant to contact open flames or very hot surfaces such as electric welding arc, electric heating element and lighted smoking materials.

DO NOT heat refrigerant over 52°C (125°F) in a closed container. Heated refrigerant will develop high pressure which can burst the container.

Keep refrigerant containers away from heat sources. Store refrigerant in a cool place.

DO NOT handle damp refrigerant container with your bare hands. Skin may freeze to container. Wear gloves.

If skin freezes to container, pour COOL water over container to free the skin. Go to a physician or hospital immediately for treatment.

Go to [Section_18:Group_1830](#)

CED,OUTX547,172-19-19981021

R134a Refrigerant Cautions** CAUTION:**

DO NOT allow liquid refrigerant to contact eyes or skin. Liquid refrigerant will freeze eyes or skin on contact. Wear goggles, gloves and protective clothing.

If liquid refrigerant contacts eyes or skin, DO NOT rub the area. Splash large amounts of COOL water on affected area. Go to a physician or hospital immediately for treatment.

DO NOT allow refrigerant to contact open flames or very hot surfaces such as electric welding arc, electric heating element and lighted smoking materials.

DO NOT heat refrigerant over 52°C (125°F) in a closed container. Heated refrigerant will develop high pressure which can burst the container.

Keep refrigerant containers away from heat sources. Store refrigerant in a cool place.

DO NOT handle damp refrigerant container with your bare hands. Skin may freeze to container. Wear gloves.

If skin freezes to container, pour COOL water over container to free the skin. Go to a physician or hospital immediately for treatment.

Go to [Section_18:Group_1830](#)

CED,OUTX547,172-19-19981021

R134a Compressor Oil Charge Check

Remove compressor if R134a leakage was detected and repaired. [See Compressor Remove and Install](#) . (Group 1830.)

Drain oil from the compressor and record the amount. [See R134a Compressor Oil Removal](#) . (Group 1830.)

NOTE:

Drain oil and save if this is a new compressor.

If the oil drained from a compressor removed from operation is very black or the amount of oil is less than specification, perform the following:

Item	Measurement	Specification
Compressor Oil Volume		6.0 mL 0.2 fl oz

1. Remove and discard the receiver-dryer.
2. Remove, clean, but do not disassemble the valve.
3. Flush the complete system with TY16134 air conditioning flushing solvent.
4. If the compressor is serviceable, pour flushing solvent in the manifold ports and internally wash out the old oil.
5. Install a new receiver-dryer.
6. Install required amount of TY22025 refrigerant oil in the compressor. [See R134a Component Oil Charge](#) . (Group 1830.)
7. Connect all components, evacuate and charge the system.

Go to [Section_18:Group_1830](#)

CED,OUTX547,173-19-20040505

R134a Compressor Oil Removal

1. Remove compressor from machine. [See Compressor Remove and Install](#) . (Group 1830.)
2. Remove inlet/outlet manifold from compressor, and clutch dust cover.
3. Drain oil into graduated container while rotating compressor shaft.
4. Record measured oil and discard oil properly.
5. Install new oil. [See R134a Component Oil Charge](#) . (Group 1830.)
6. Install compressor. [See Compressor Remove and Install](#) . (Group 1830.)

Go to [Section_18:Group_1830](#)

CED,OUTX547,174-19-20040505

R134a Component Oil Charge

CAUTION:

All new compressors are charged with a mixture of nitrogen, R134a refrigerant and TY22025 (R134a) refrigerant oil. Wear safety goggles and discharge the compressor slowly to avoid possible injury.

Compressors can be divided into three categories when determining the correct oil charge for the system.

- New compressor from parts depot
- Used compressor removed from operation
- Compressor internally washed with flushing solvent

Use the following procedure to determine the amount of system oil charge prior to installation of compressor on a machine.

1. When the complete system, lines, and components were flushed add the correct amount of oil as described.

- New compressor from parts depot contains a amount of new oil. System requires an additional amount of new oil.

Item	Measurement	Specification
Oil, New Compressor Installation, Complete System Flushed	Supplied Volume	210—250 mL 7.0—8.4 fl oz
	Additional Volume	32.5 mL 1.1 fl oz

- Used compressor removed from operation, oil drained, and flushed requires specified amount of new oil.

Item	Measurement	Specification
Oil, Used Compressor Installation, Complete System Flushed	Volume	260 mL 8.8 fl oz

2. When the complete system was not flushed add the correct amount of oil for the compressor plus the amount of oil for each component that was serviced.

- New compressor from parts depot, drain and return specified amount of oil to the compressor. [See R134a Compressor Oil Removal](#) . (Group 1830.)

Item	Measurement	Specification
Oil, New Compressor Installation, Complete System Not Flushed	Volume	Drain and return 45 mL
		Drain and return 1.5 fl oz

- Used compressor removed from operation and oil drained. [See R134a Compressor Oil Removal](#) . (Group 1830.) Add specified amount of new oil.

Item	Measurement	Specification
Oil, Used Compressor Installation, Complete System Not Flushed, Oil Drained	Volume	Add 45 mL Add 1.5 fl oz

- Used compressor removed from operation, oil drained, and flushed add specified amount of new oil.

Item	Measurement	Specification
Oil, Used Compressor Installation, Complete System Not Flushed, Oil Drained, Flushed	Volume	Add 60 mL Add 2.0 fl oz

3.

NOTE:

Hoses = 3 mL per 0.3 m (0.1 fl oz per ft). Approximate total length equals 12.5 m (41.0 ft).

If any section of hose is removed and flushed or replaced, measure the length of hose and use the formula to determine the correct amount of oil to be added.

⚠ CAUTION:

DO NOT leave the system or R134a compressor oil containers open. This oil easily absorbs moisture. DO NOT spill R134a compressor oil on acrylic or ABS plastic. This oil will deteriorate these materials rapidly. Identify R134a oil containers and measures to eliminate accidental mixing of different oils.

Components listed below which have been removed, drained or flushed, require the removal of the compressor to determine the correct oil charge. Use the following chart as a guide for adding oil to components:

Item	Measurement	Specification
Evaporator	Oil Charge	32.5 mL 1.1 fl oz
Condenser	Oil Charge	32.5 mL 1.1 fl oz
Receiver/Dryer	Oil Charge	30 mL 1.0 fl oz
Hoses	Oil Charge	121.2 mL approximate 4.1 fl oz approximate

Go to [Section_18:Group_1830](#)

CED,OUTX547,175-19-20040505

Leakage Testing

1. Inspect all lines, fittings, and components for oily or dusty spots. When refrigerant leaks from the system, a small amount of oil is carried out with it.
2. A soap and water solution can be sprayed on the components in the system to form bubbles at the source of the leak.
3. If a leak detector is used, move the leak detector probe under the hoses and around the connections at specified rate.
4. Some refrigerant manufacturers add dye to refrigerant to aid in leak detection.

Go to [Section_18:Group_1830](#)

CED,OUO1066,309-19-20040505

R134a Refrigerant Recovery, Recycling and Charging Station Installation Procedure

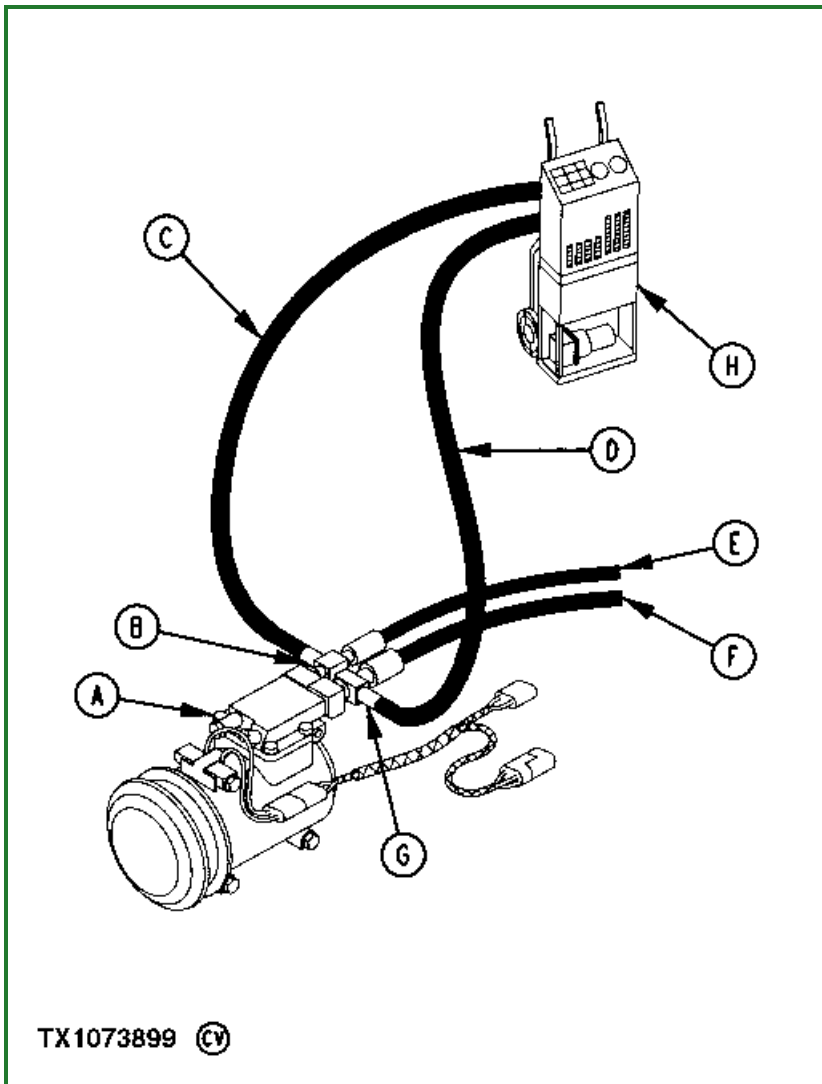

TX1073899-UN: R134a Refrigerant Recovery, Recycling and Charging Station

LEGEND:

- A - High Pressure Relief Valve
- B - High Pressure Test Port
- C - Red Hose
- D - Blue Hose
- E - High Pressure Hose
- F - Low Pressure Hose
- G - Low Pressure Test Port
- H - Refrigerant Recovery/Recycling and Charging Station

⚠ CAUTION:

Do not remove high pressure relief valve (A). Air conditioning system will discharge rapidly causing possible injury.

IMPORTANT:

Use correct refrigerant recovery, recycling and charging stations. DO NOT mix refrigerant, hoses, fittings, components or refrigerant oils.

1. Close both high and low pressure valves on refrigerant recovery, recycling and charging station (H).

2. Remove cap from low pressure test port (G).
3. Connect low pressure blue hose (D) from refrigerant recovery, recycling and charging station (H) to low pressure test port (G) on compressor.
4. Connect high pressure red hose (C) to high pressure quick disconnect (B).
5. Follow the manufacturers instructions when using the refrigerant recovery, recycling and charging station.

Go to [Section_18:Group_1830](#)

CED,OUTX547,176-19-20100322

Recover R134a System

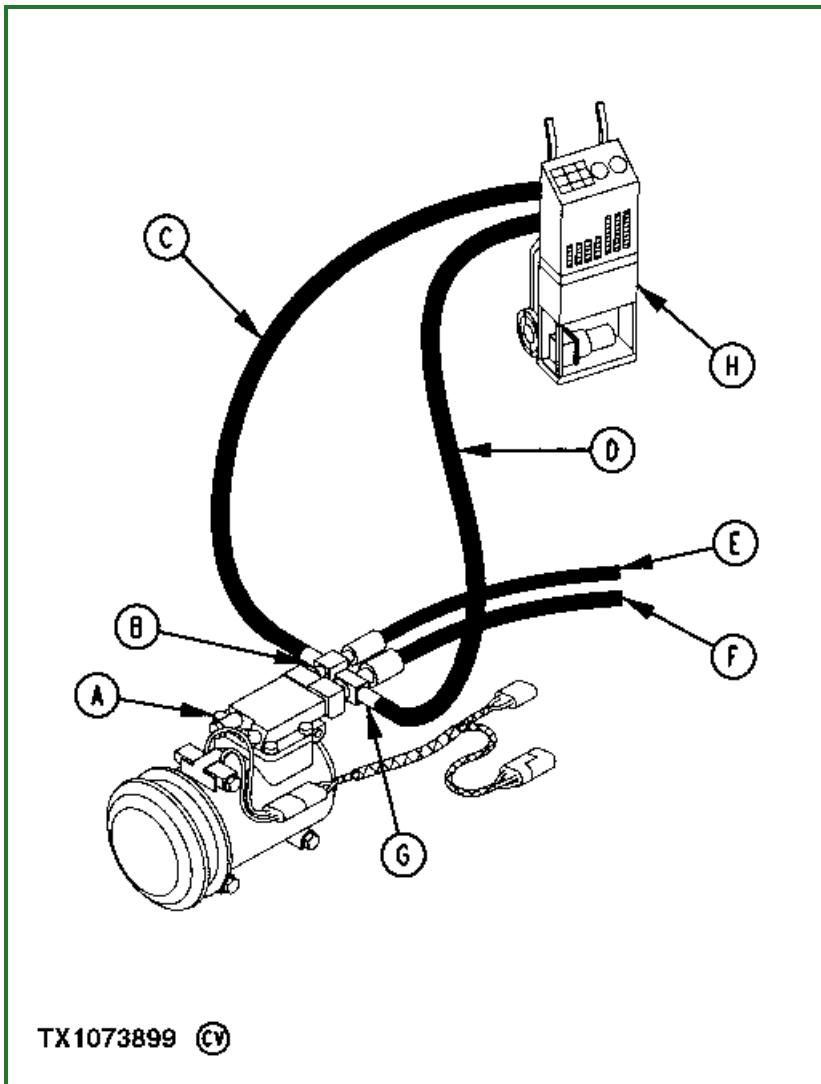

TX1073899-UN: Recover R134a System

LEGEND:

- A - High Pressure Relief Valve
- B - High Pressure Test Port
- C - Red Hose
- D - Blue Hose
- E - High Pressure Hose
- F - Low Pressure Hose
- G - Low Pressure Test Port
- H - Refrigerant Recovery/Recycling and Charging Station

⚠ CAUTION:

Do not remove high pressure relief valve (A). Air conditioning system will discharge rapidly causing possible injury.

IMPORTANT:

Use correct refrigerant recovery, recycling and charging stations. DO NOT mix refrigerant, hoses, fittings, components or refrigerant oils.

1. **NOTE:**

Run the air conditioning system for three minutes to help in the recovery process. Turn air conditioning system off before proceeding with recovery steps.

Connect refrigerant recovery, recycling and charging station. [See R134a Refrigerant Recovery, Recycling and Charging Station Installation Procedure . \(Group 1830.\)](#)

2. Follow the manufacturers instructions when using the refrigerant recovery, recycling and charging station.

Go to [Section_18:Group_1830](#)

CED,OUTX547,177-19-20100322

Evacuate R134a System

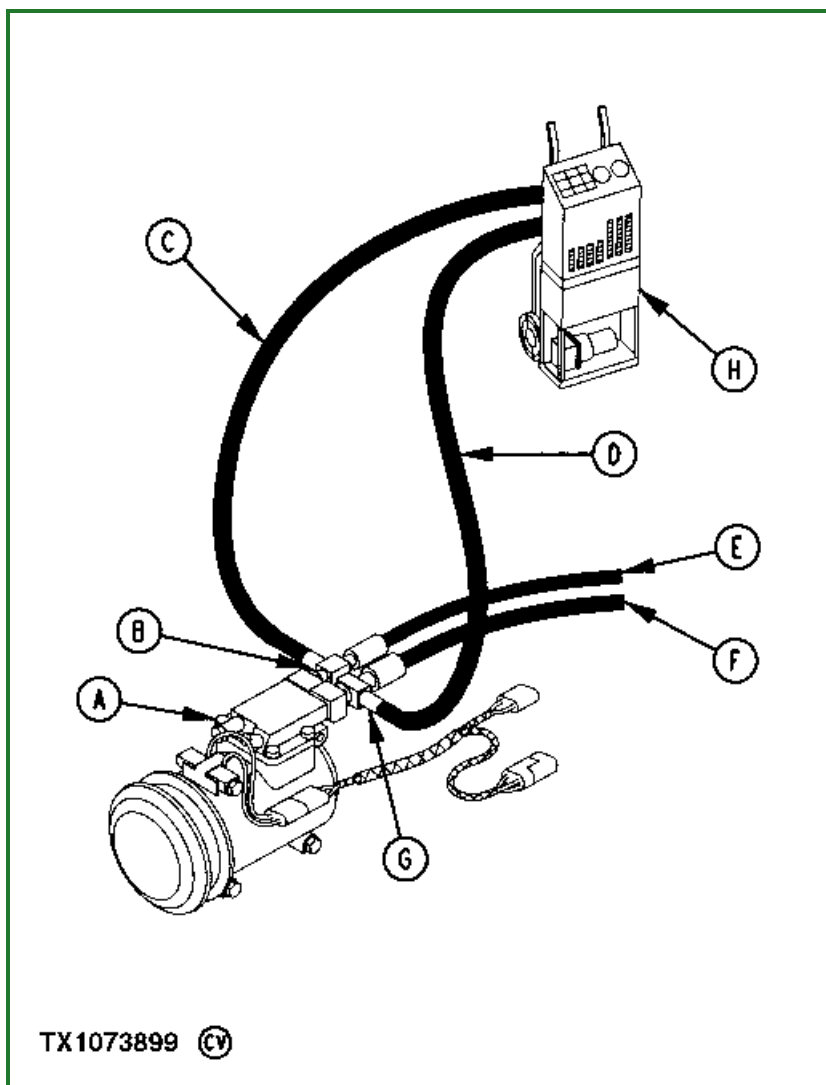

TX1073899-UN: Evacuate R134a System

LEGEND:

- A - High Pressure Relief Valve
- B - High Pressure Test Port
- C - Red Hose
- D - Blue Hose
- E - High Pressure Hose
- F - Low Pressure Hose
- G - Low Pressure Test Port
- H - Refrigerant Recovery/Recycling and Charging Station

⚠ CAUTION:

Do not remove high pressure relief valve (A). Air conditioning system will discharge rapidly causing possible injury.

IMPORTANT:

Use correct refrigerant recovery, recycling and charging stations. DO NOT mix refrigerant, hoses, fittings, components or refrigerant oils.

Do not run compressor while evacuating.

1. Connect refrigerant recovery, recycling and charging station. [See R134a Refrigerant Recovery, Recycling and Charging Station Installation Procedure](#) . (Group 1830.)
2. Open low and high pressure valves on refrigerant recovery, recycling and charging station.
3. Follow the manufacturers instructions and evacuate the system.

4. **NOTE:**

The vacuum specifications listed are for sea level conditions. Subtract 3.4 kPa (34 mbar) (1 in. Hg) from 98 kPa (980 mbar) (29 in. Hg) for each 300 m (1000 ft) elevation above sea level.

Evacuate system until low pressure gauge registers specified vacuum.

If specified vacuum cannot be obtained in 15 minutes, test the system for leaks. [See Leak Testing](#) . (Group 1830.) Correct any leaks.

Item	Measurement	Specification
Vacuum	Pressure at Sea Level	98 kPa 980 mbar 29 in. Hg
	Pressure Above Sea Level	Subtract 3.4 kPa from 98 kPa for each 300 m elevation Subtract 34 mbar from 980 mbar for each 300 m elevation Subtract 1 in. Hg from 29 in. Hg for each 1000 ft elevation

5. When vacuum reaches specified level, close low-side and high-side valves. Turn vacuum pump off.
6. If the vacuum decreases more than specified amount in 5 minutes, there is a leak in the system.

Item	Measurement	Specification
Leak Present	Decrease in Vacuum	3.4 kPa 34 mbar 1 in. Hg

7. Repair leak.
8. Start to evacuate.
9. Open low-side and high-side valves.
10. Evacuate system for 30 minutes after initial specified vacuum is reached.
11. Close low-side and high-side valves. Stop evacuation.
12. [See Charge R134a System](#) . (Group 1830.)

Go to [Section_18:Group_1830](#)

CED,OUTX547,178-19-20100322

Charge R134a System

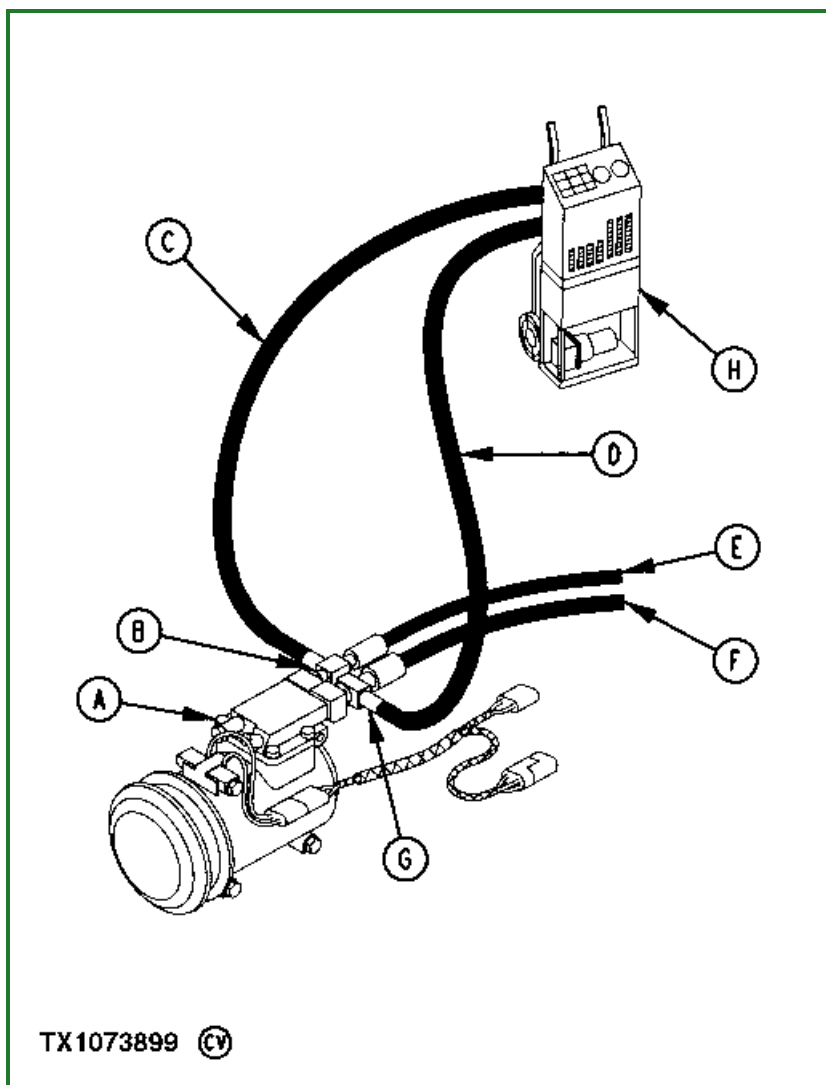

TX1073899-UN: Charge R134a System

LEGEND:

- A - High Pressure Relief Valve
- B - High Pressure Test Port
- C - Red Hose
- D - Blue Hose
- E - High Pressure Hose
- F - Low Pressure Hose
- G - Low Pressure Test Port
- H - Refrigerant Recovery/Recycling and Charging Station

⚠ CAUTION:

Do not remove high pressure relief valve (A). Air conditioning system will discharge rapidly causing possible injury.

IMPORTANT:

Use correct refrigerant recovery, recycling and charging stations. **DO NOT** mix refrigerant, hoses, fittings, components or refrigerant oils.

1. Connect JT02045 R134a refrigerant recovery, recycling and charging station. [See R134a Refrigerant](#)

Recovery, Recycling and Charging Station Installation Procedure . (Group 1830.)

2. Evacuate the system. See [Evacuate R134a System](#) . (Group 1830.)

3.

NOTE:

Before beginning to charge air conditioning system, the following conditions must exist: Engine STOPPED, the pump must be capable of pulling at least 28.6 in. Hg vacuum (sea level). Subtract 3.4 kPa (34 mbar) (1 in. Hg) from 98 kPa (980 mbar) (29 in. Hg) for each 300 m (1000 ft) elevation above sea level.

Follow the manufacturers instructions and charge the system.

4. Add refrigerant until system is charged to specification.

Item	Measurement	Specification
Refrigerant Weight		1.6 kg
		3.5 lbs

5. [Perform Air Conditioner Check](#) (Group 9005-10.)

Go to [Section_18:Group_1830](#)

CED,OUTX547,179-19-20100322

Air Conditioner System Cleaning Procedures

Flushing

Flushing the system or component is a cleaning process using a liquid solvent to remove oil and debris. Purging is always necessary after flushing to remove solvent from the system or component.

Following is a list of situations that require a flushing procedure be done:

1. The compressor has an internal failure.
2. No oil remains in used compressor.
3. Oil drained from compressor appears or smells overheated.
4. System was contaminated with a mixture of refrigerant oils.
5. System was left open to the atmosphere long enough for dirt, moisture, or debris to enter the tubing or components.
6. System has an internal blockage.

The following solvent is recommended for flushing air conditioner systems. Use only solvents with an equivalent MSDS.

- TY16134 Air Conditioning System Flushing Solvent

Purging

Purging the system or a component is a cleaning process using a gas to force liquid from the system. Purging alone will not remove refrigerant oil from the system.

Following is a list of situations that require a purging procedure be done:

- After flushing system with solvent, to prevent oil dilution
- System was contaminated with nitrogen or two refrigerants.
- System was left open to the atmosphere and flushing could not be performed.
- Installation of new lines, condenser, or evaporator was required.

Evacuating

Evacuating the system is a process to remove air and moisture from the system, creating a vacuum. [See Evacuate R134a System](#) . (Group 1830.)

Go to [Section_18:Group_1830](#)

MF82180,00001DD-19-20060317

Purge R134a System

IMPORTANT:

Air compressors used for purging systems require a water separator. Purging without a separator adds moisture, creating hydrofluoric acid when combined with refrigerant oil. Acid is corrosive to metal tubing.

1. Connect dry nitrogen hose to gauge manifold center hose.
2. Connect gauge manifold suction hose to compressor suction port, and open valves.
3. Connect gauge manifold discharge hose to compressor discharge post, and open valve. Disconnect discharge hose from gauge manifold to allow purging nitrogen to atmosphere.
4. Open nitrogen tank valve and adjust regulator to Specification. Purge system for two minutes. Disconnect nitrogen supply.

Item	Measurement	Specification
Nitrogen Purge	Pressure	275 kPa for two minutes 2.75 bar for two minutes 40 psi for two minutes

5. Evacuate system. [See Evacuate R134a System](#) . (Group 1830.)

Go to [Section_18:Group_1830](#)

CED, TX03399, 2292-19-20040505

Flush R134a System

Add flushing solvent to system with JT02075 Air Conditioning Flusher and JT02098 Fitting Kit.

NOTE:

Flushing can be performed on vehicle.

1. Recover refrigerant. See [Recover R134a System](#) . (Group 1830.)
2. Remove compressor and measure oil drained from both manifold ports.
3. Clean compressor as follows:
 1. Pour specified amount of flushing solvent into suction port and Specified amount of flushing solvent into discharge port. Plug both ports in compressor manifold, using Caps.

Item	Measurement	Specification
Compressor Flushing Solvent	Quantity in Suction Port	240 mL 8 fl oz
	Quantity in Discharge Port	120 mL 4 fl oz

2. Turn compressor end for end and roll it side to side.
 3. Remove both plugs from manifold ports and drain solvent from compressor.
 4. Connect battery power to compressor clutch coil. Rotate pulley at least five revolutions to move solvent out of cylinders.
 5. Invert compressor, roll end for end, and side to side. Drain thoroughly.
 6. Let compressor sit inverted for three to five minutes.
 7. Repeat previous two steps at least three times.
4. Remove and discard receiver-dryer.
 5. Divide system into two circuits:
 1. Condenser, including inlet and outlet hoses.
 2. Evaporator, including inlet and outlet hoses.
 6. IMPORTANT:

DO NOT attempt to flush through compressor or receiver-dryer. Flushing through expansion valve is acceptable if refrigerant oil has normal odor and appearance.

To Flush/Purge Condenser:

Connect flusher outlet hose to inlet end of compressor discharge line using JT02102 Adapter.

7. Attach a return hose and aerator nozzle to outlet end of receiver/dryer inlet hose using JT03197 Adapter. Put nozzle in container to collect flushing solvent.

- Fill flusher tank with solvent and fasten all connections.

Item	Measurement	Specification
Flusher Tank	Capacity	4 L 1 gal

- NOTE:**

Air pressure must be at least 620 kPa (6.2 bar) (90 psi) for flushing and purging.

Connect a supply line of moisture-free compressed air or dry nitrogen to flusher air valve. Adjust regulator to specification.

Item	Measurement	Specification
Regulated Air	Minimum Pressure	620 kPa 6.2 bar 90 psi

- Open air valve to force flushing solvent into condenser circuit. Flusher tank is empty when hose pulsing stops. Additional flushing cycles are required if system is heavily contaminated with burned oil or metal particles.

- IMPORTANT:**

Purging the condenser circuit takes 10—12 minutes to thoroughly remove solvent.

Disconnect hose from aeration nozzle to check circuit for solvent. Hold hose close to a piece of cardboard; continue purging until cardboard is dry.

Flush Evaporator

- If system is contaminated with burned refrigerant oil or debris, remove and bench flush evaporator. Go to Step 18 to flush evaporator through expansion valve, if oil appears normal. Remove evaporator. [See Evaporator or Heater Core Remove and Install](#) . (Group 1830.)
- Force flushing solvent through evaporator inlet with compressed air.
- Purge system until dry.
- Reinstall evaporator.

Flush Evaporator Through Expansion Valve

- Connect flusher outlet hose to connection of receiver/dryer outlet hose using JT03188 Adapter.
- Attach a hose and aerator nozzle to compressor inlet line using JT02101 Adapter. Put nozzle in a container to collect solvent.
- Repeat Steps 8, 9 and 10 to flush evaporator.

- NOTE:**

Purging the evaporator circuit takes 12—15 minutes to thoroughly remove solvent.

Disconnect hose from aeration nozzle to check circuit for solvent. Hold hose close to a piece of cardboard. Continue purging until cardboard is dry.

1. Install a new receiver-dryer compatible with R134a refrigerant. Tighten connections and mounting bracket.
2. Add required oil. [See R134a Component Oil Charge](#) . (Group 1830.)
3. Install compressor, and connect refrigerant lines to manifold.
4. Connect clutch coil wire. Install drive belt.
5. Purge system. [See Purge R134a System](#) . (Group 1830.)

Go to [Section_18:Group_1830](#)

CED, TX03399, 2293-19-20040505

Evaporator or Heater Core Remove and Install

NOTE:

Anytime air conditioning system is discharged, a new receiver-dryer must be installed.

1. Remove cap screws to remove access cover to air conditioning and heater assembly.
2. Recover air conditioning system. [See Recover R134a System](#) . (Group 1830.)

3.

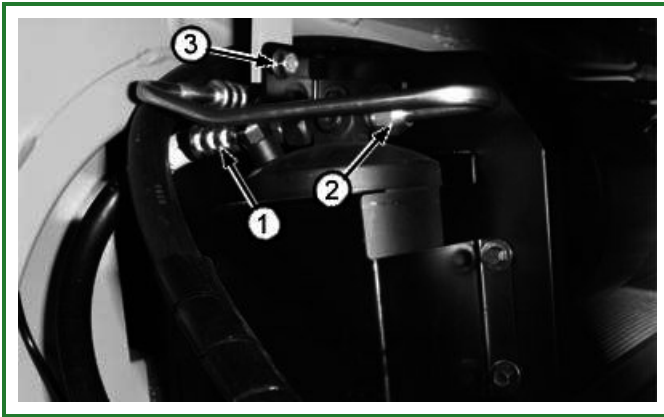

T118219B-UN: Receiver-Dryer Lines

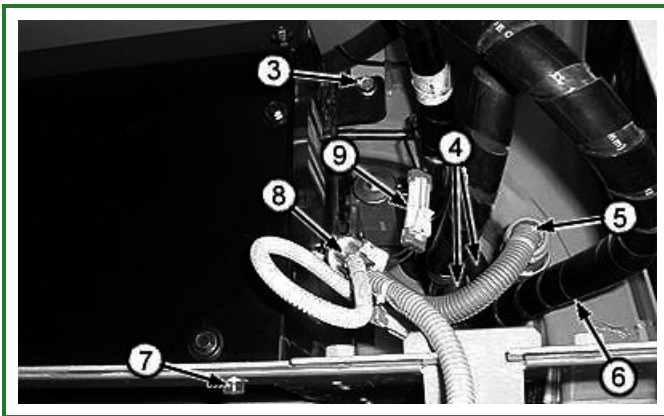

T118220B-UN: Expansion Valve, Plate and Bracket

LEGEND:

- 1 - Receiver-Dryer Hose-to-Condenser
- 2 - Receiver-Dryer Hose from Evaporator
- 3 - Cap Screw (2 used)
- 4 - Two Heater Hoses-to-Under the Seat Heater Core
- 5 - A/C Harness Connector-to-Cab Harness Connector
- 6 - Expansion Valve Hose-to-Compressor
- 7 - Cap Screw (8 used)
- 8 - A/C Blower Fans and Switch Connector
- 9 - Low Pressure Switch Connector

Disconnect (1, 2, 4—6, 8 and 9).

4. Remove Cap Screw (3) on both sides.

5. Remove eight screws (7) and remove A/C and heater assembly.

6.

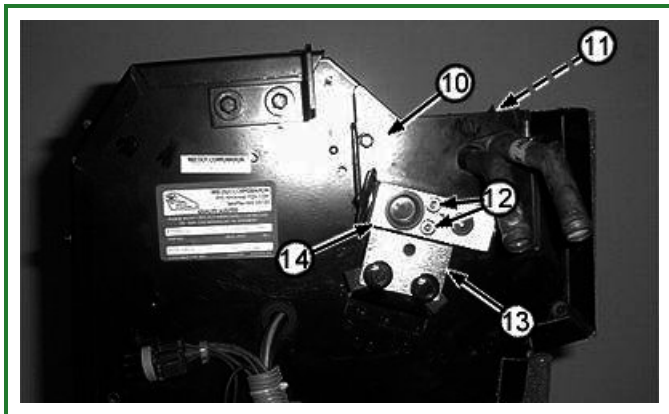

T118221B-UN: Expansion Valve, Plate and Bracket

LEGEND:

- 10 - Plate
- 11 - Evaporator/Heater Core Cover
- 12 - Cap Screw (2 used)
- 13 - Bracket
- 14 - Expansion Valve

Disconnect lines and bracket from expansion valve (14).

7. Remove two screws (12) and remove expansion valve.

8. Remove bracket (13).

9. Remove two cap screws and remove plate (10).

10. Remove cover (11) and remove evaporator or heater core.

11.

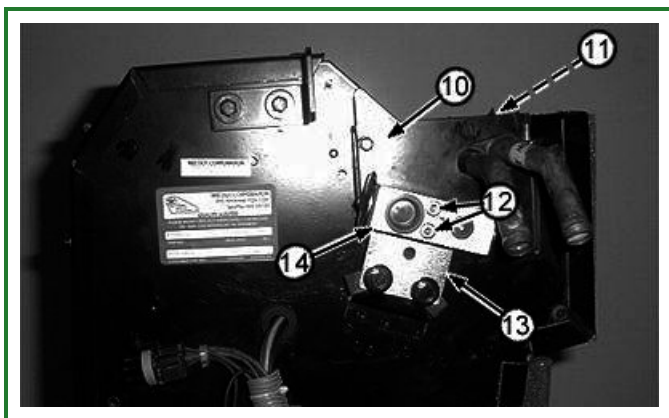

T118221B-UN: Expansion Valve, Plate and Bracket

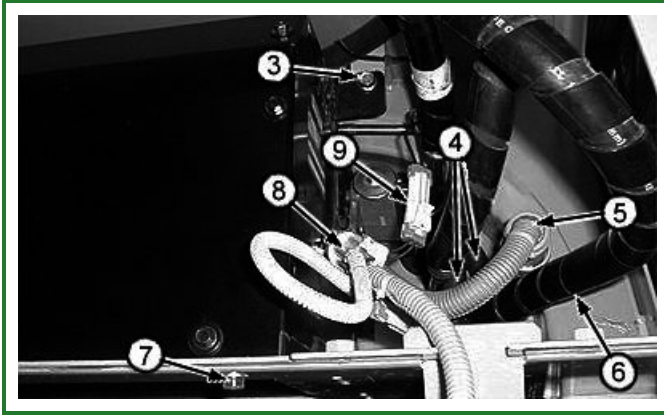

T118220B-UN: Receiver/Dryer Lines

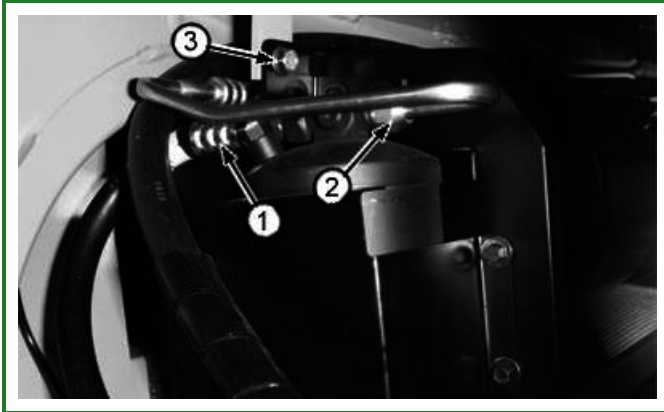

T118219B-UN: A/C and Heater Lines and Wiring Connectors

LEGEND:

- 1 - Receiver-Dryer Hose-to-Condensor
- 2 - Receiver-Dryer Hose from Evaporator
- 3 - Cap Screw (2 used)
- 4 - Two Heater Hoses-to-Under the Seat Heater Core
- 5 - A/C Harness Connector-to-Cab Harness Connector
- 6 - Expansion Valve Hose-to-Compressor
- 7 - Cap Screw (8 used)
- 8 - A/C Blower Fans and Switch Connector
- 9 - Low Pressure Switch Connector
- 10 - Plate
- 11 - Evaporator/Heater Core Cover
- 12 - Cap Screw (2 used)
- 13 - Bracket
- 14 - Expansion Valve

Install evaporator or heater core.

12. Install (11, 10, 13, and 14). Tighten cap screws.
13. Connect (4—6, 8 and 9). Tighten cap screws (3 and 7).
14. Connect hoses (1 and 2).
15. Install access cover and tighten cap screws.
16. Install new receiver/dryer.

17. Apply refrigerant oil to new O-rings and immediately connect lines.
18. Add oil. [See R134a Component Oil Charge](#) . (Group 1830)
19. Evacuate and charge the air conditioning system. [See Evacuate R134a System](#) (Group 1830) and [See Charge R134a System](#) . (Group 1830)

Go to [Section_18:Group_1830](#)

KV70328,0000079-19-20091216

Expansion Valve Remove and Install

NOTE:

Anytime air conditioning system is discharged, a new receiver-dryer must be installed.

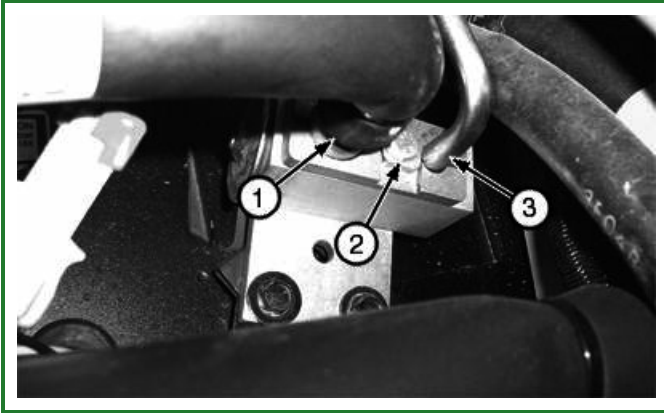

T200241A-UN: Expansion Valve

LEGEND:

- 1 - Expansion Valve Hose-to-Compressor
- 2 - Cap Screw and Bracket
- 3 - Expansion Valve Hose-to-Receiver/Dryer

1. Open Access cover
2. Recover the air conditioning system. [See Recover R134a System](#) . (Group 1830.)
3. Disconnect hoses (1 and 3) and remove cap screw and bracket (2).
4. Remove two screws on expansion valve and remove valve.
5. Install expansion valve and cap screw. Tighten cap screw to specification.

Item	Measurement	Specification
Cap Screw	Torque	5.2—6.2 N·m 46—55 lb-in.

6. Install bracket and connect hoses. Install new receiver-dryer. [See Receiver-Dryer Remove and Install](#) . (Group 1830.)
7. Apply refrigerant oil to new O-rings and immediately connect lines.
8. Add oil. [See R134a Component Oil Charge](#) . (Group 1830.)
9. Evacuate and charge the air conditioning system. [See Evacuate R134a System](#) and [See Charge R134a System](#) . (Group 1830.)

Go to [Section_18:Group_1830](#)

SK44377,00002B4-19-20141201

A/C Freeze Switch Remove and Install

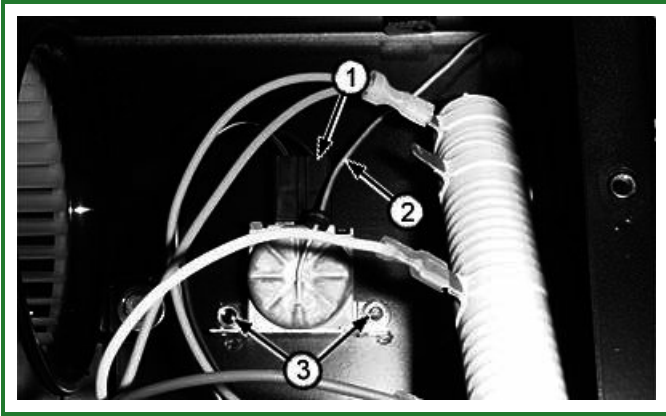

T118417B-UN: A/C Freeze Switch

LEGEND:

1 - Connector

2 - Sensor

3 - Cap Screw (2 used)

1. Disconnect connector (1).
2. Remove sensor (2) from evaporator.
3. Remove cap screws (3).

Go to [Section_18:Group_1830](#)

CED,TX03399,5071-19-20040506

Upper Cab Heater Blower Motor and Heater Blower Resistor Remove and Install

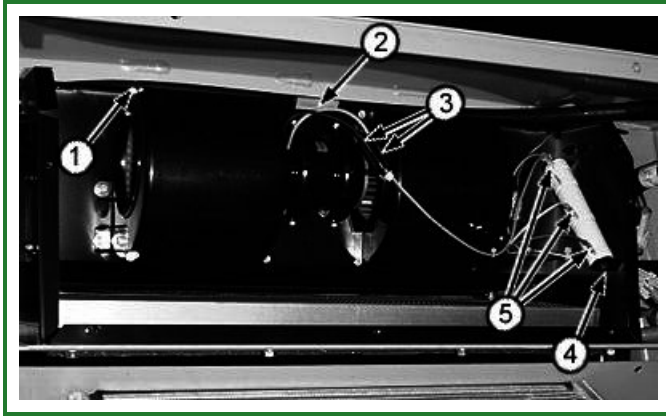

T118407B-UN: Blower Motor and Heater Blower Resistor

LEGEND:

- 1 - Cap Screw (4 used)
- 2 - Cap Screw
- 3 - Blower Motor Connector (2 used)
- 4 - Resistor Cap Screw
- 5 - Resistor Wire Lead (3 used)

1. Remove A/C and heater access cover.
2. Remove blower motor cover (for blower motor only).
3. Disconnect blower motor connectors (3). Remove cap screws (1 and 2).
4. Remove blower motor.
5. Disconnect leads (5) and cap screw (4) to remove heater resistor.
6. Install new resistor and connect leads and install cap screw (4).
7. Install blower motor and connect connectors.
8. Install covers.

Go to [Section_18:Group_1830](#)

CED, TX03399, 5066-19-20090729

Cab Upper Heater Disassemble and Assemble

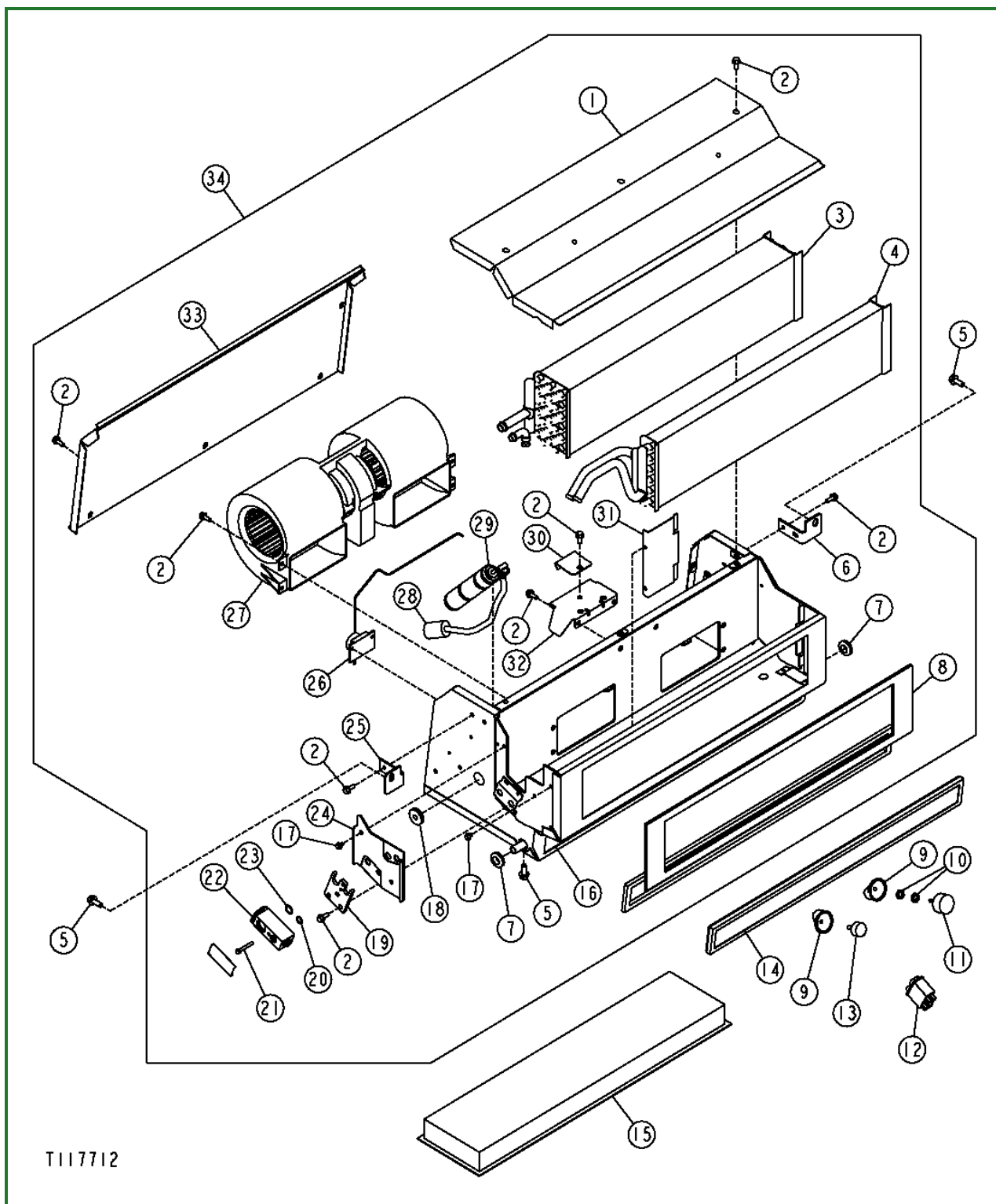

T117712-UN: Cab Heater

LEGEND:

- 1 - Top Cover
- 2 - Cap Screw (24 used)
- 3 - Evaporator Core
- 4 - Heater Core
- 5 - Cap Screw (10 used)
- 6 - Bracket
- 7 - Grommet (2 used)
- 8 - Gasket Kit

- 9 - Switch Knob (2 used)
- 10 - Nut (2 used)
- 11 - Rotary Switch
- 12 - Heater Switch
- 13 - Heater Control Switch
- 14 - Recirculation Filter
- 15 - Fresh Air Filter
- 16 - Main Housing
- 17 - Cap Screw (4 used)
- 18 - Grommet
- 19 - Mount Plate
- 20 - O-Ring
- 21 - Cap Screw (2 used)
- 22 - Thermal Expansion Valve
- 23 - O-Ring
- 24 - Plate
- 25 - Bracket
- 26 - Freeze Control Switch
- 27 - Blower Fan
- 28 - Wiring Harness
- 29 - Resistor
- 30 - Motor Support Retainer
- 31 - Motor Retainer
- 32 - Bracket
- 33 - A/C Back Cover
- 34 - Upper Heater Assembly

Go to [Section_18:Group_1830](#)

CED,TX03399,5025-19-20060309

Cab or ROPS Under Seat Heater Disassemble and Assemble

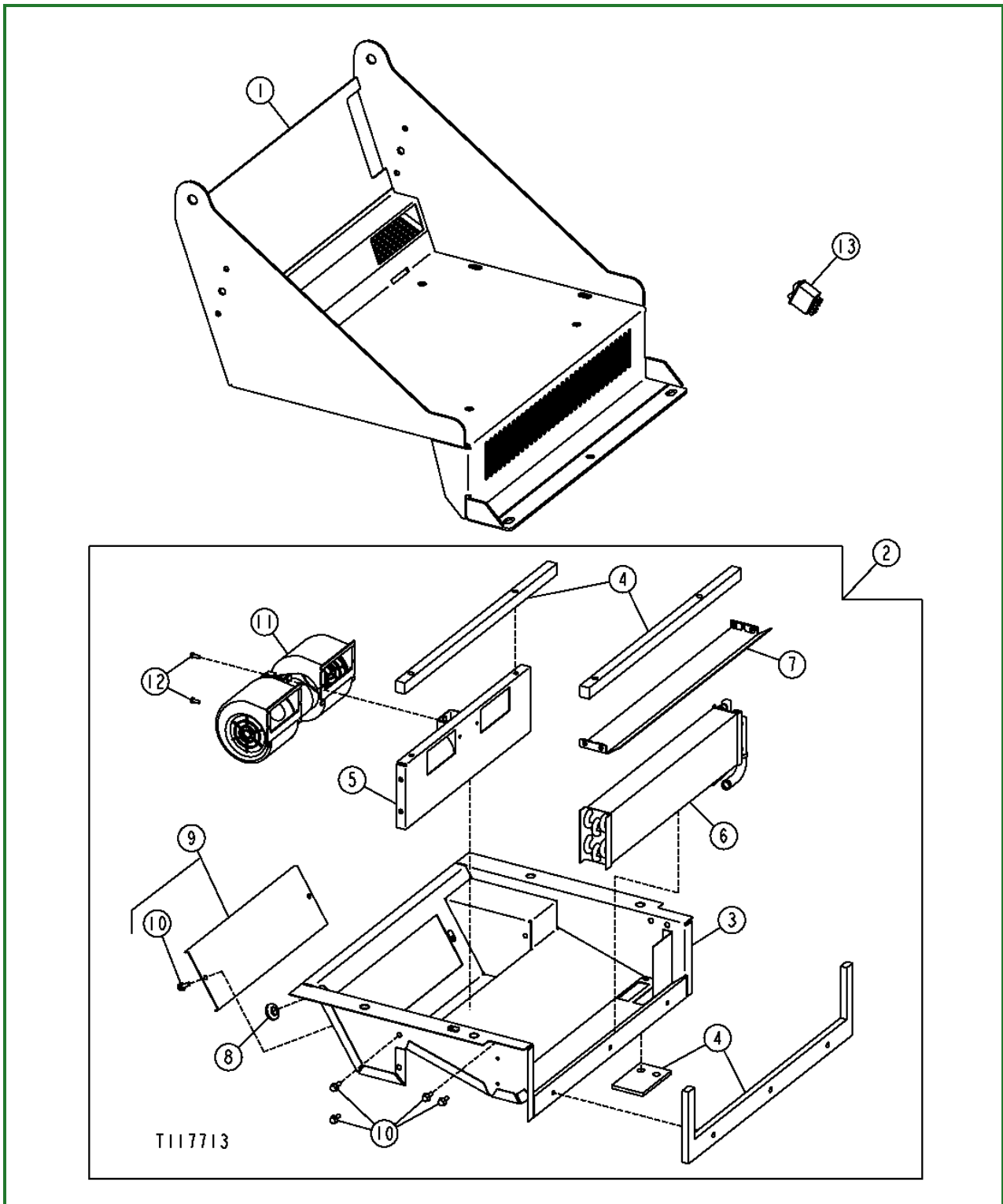

T117713-UN: Under Seat Heater and Blower Assembly

LEGEND:

- 1 - Heater Base
- 2 - Heater Assembly
- 3 - Heater Tray
- 4 - Gasket Kit
- 5 - Blower Motor Bulkhead
- 6 - Heater Core
- 7 - Support
- 8 - Wiring Harness (Not Shown) with Grommet

- 9 - Backing Plate
- 10 - Cap Screw (10 used)
- 11 - Blower
- 12 - Cap Screw (2 used)
- 13 - Switch

1. Drain engine coolant. [see 450J-LT and 450J-LGP Crawler Dozer Drain and Refill Capacities](#) or [See 550J-LT and 550J-LGP Crawler Dozer Drain and Refill Capacities](#) . (Operator's Manual.)
2. Remove floor mat and floor access plate.
3. For machines equipped with a toolbox, pull out drawer and remove cap screw holding toolbox in place. Remove toolbox.

4.



T116758B-UN: Seat Base Cap Screws

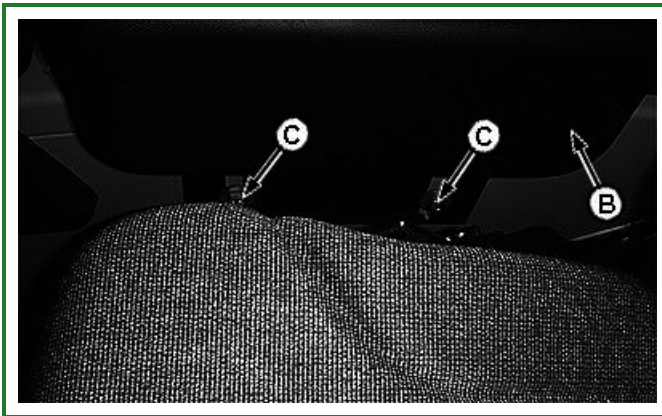

T116757B-UN: Seat Armrest Cap Screws

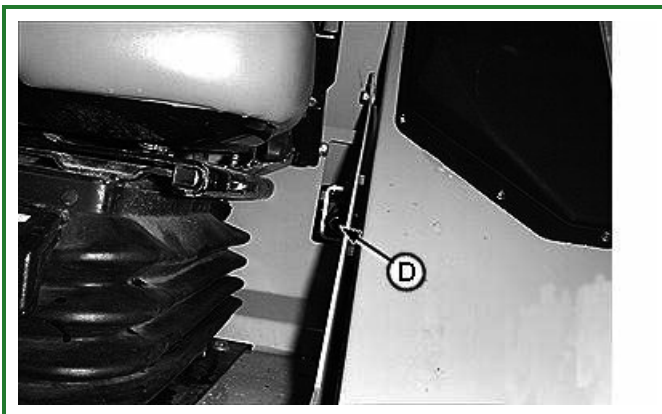

T200435A-UN: Jack Screw

LEGEND:

- A - Cap Screws Around Seat Box Bottom (4 used)
- B - Armrest
- C - Shoulder Cap Screws (2 used)
- D - Jack Screw
- E - Knee Pad

Remove four cap screws (A) from around seat box bottom.

5. Remove shoulder cap screws (C) from seat box under armrest (B) on both sides of seat.
6. Remove two cap screws from knee pad (E) on both sides of seat (if equipped).
7. On units equipped with rear screen or cab, tilt back of seat forward.
8. Tilt seat up as far as possible with jack screw (D) located in left rear corner of seat box.
9. Disconnect blower wire connector and heater hoses.
10. Remove heater/blower assembly
11. Remove part as necessary.
12. Assemble parts and lower seat.
13. Install floor access plate and floor mat.
14. Fill engine coolant. [see 450J-LT and 450J-LGP Crawler Dozer Drain and Refill Capacities](#) or [See 550J-LT and 550J-LGP Crawler Dozer Drain and Refill Capacities](#) . (Operator's Manual.)

Go to [Section_18:Group_1830](#)

CED,TX03399,5024-19-20180215

Receiver-Dryer Remove and Install

NOTE:

Anytime air conditioning system is discharged, a new receiver-dryer must be installed.

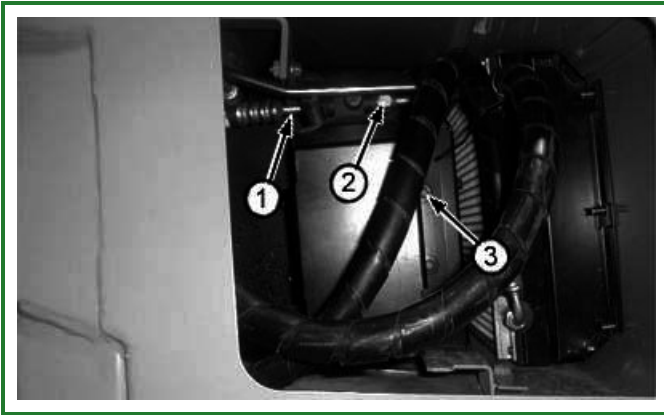

T118142B-UN: Receiver/Dryer

LEGEND:

- 1 - Receiver/Dryer Hose-to-Condenser
- 2 - Receiver/Dryer Hose-from-Evaporator
- 3 - Receiver/Dryer Bracket Cap Screw (4 used)

1. Remove left hand side cover.
2. Recover the air conditioning system. [See Recover R134a System](#) . (Group 1830.)
3. Disconnect hoses (1 and 3) and remove four cap screws (2) and remove receiver-dryer.
4. Install new receiver-dryer, and bracket. Tighten cap screws.
5. Apply refrigerant oil to new O-rings and immediately connect lines.
6. Add oil. [See R134a Component Oil Charge](#) . (Group 1830.)
7. Evacuate and charge the air conditioning system. [See Evacuate R134a System](#) and [see Charge R134a System](#) . (Group 1830.)

Go to [Section_18:Group_1830](#)

CED,OUTX547,181-19-20060309

Condenser Remove and Install

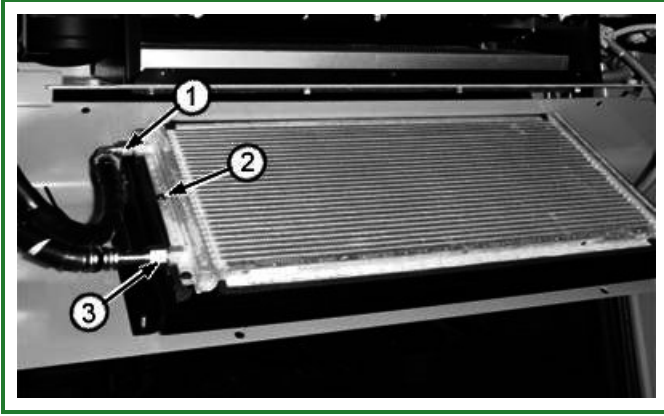

T118149B-UN: Condenser

LEGEND:

- 1 - From Receiver-Dryer-to-Condenser Hose
- 2 - Cap Screw (6 used)
- 3 - Condenser-to-Compressor Hose

NOTE:

Anytime air conditioning system is discharged, a new receiver-dryer must be installed.

If servicing the condenser fans do not disconnect condenser hoses. Remove condenser and lay to the side.

1. Remove bottom cover.
2. Recover the air conditioning system. [See Recover R134a System](#) . (Group 1830.)
3. Disconnect hoses (1 and 3) and remove six cap screws (2) and remove condenser.
4. Install condenser. Tighten cap screws.
5. Connect lines (1 and 3).
6. Install a new receiver-dryer. [See Receiver-Dryer Remove and Install](#) . (Group 1830.)
7. Apply refrigerant oil to new O-rings connect lines.
8. Add compressor oil. [See R134a Component Oil Charge](#) . (Group 1830.)
9. Evacuate and charge the air conditioning system. [See Evacuate R134a System](#) and [see Charge R134a System](#) . (Group 1830.)

Go to [Section_18:Group_1830](#)

CED,OUTX547,183-19-20060309

Compressor Remove and Install

NOTE:

Anytime air conditioning system is discharged, a new receiver-dryer must be installed.

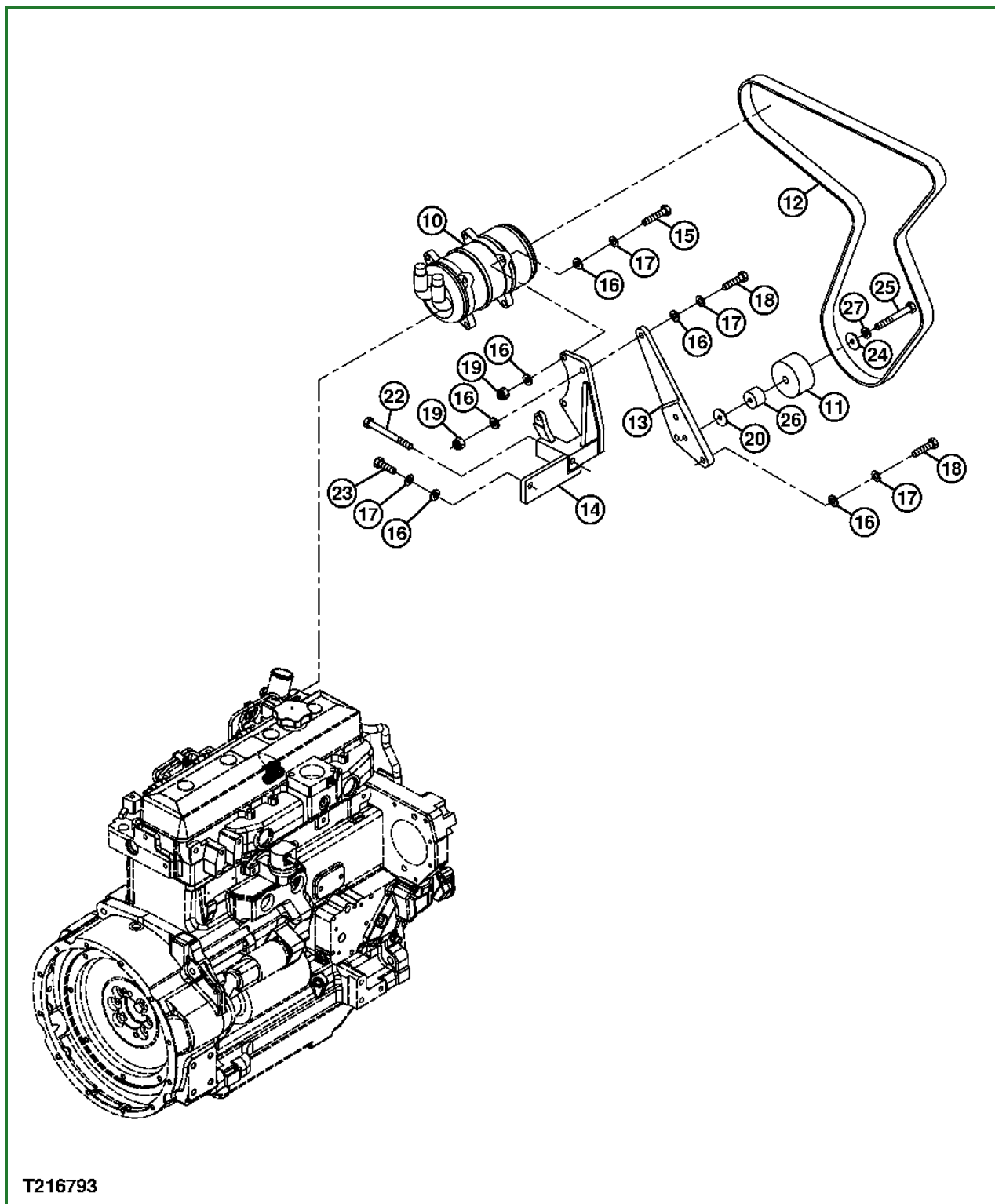

T216793-UN: Compressor

LEGEND:

- 10 - Compressor
- 11 - Idler
- 12 - Adjuster Belt
- 13 - Clamp

- 14 - Bracket
- 15 - Cap Screw
- 16 - Washer
- 17 - Washer
- 18 - Cap Screw
- 19 - Lock Nut
- 20 - Washer
- 22 - Screw
- 23 - Cap Screw
- 24 - Sleeve
- 25 - Screw
- 26 - Tube Nut
- 27 - Washer

1. Remove refrigerant from the system. [See Recover R134a System](#) . (Group 1830.)

2.

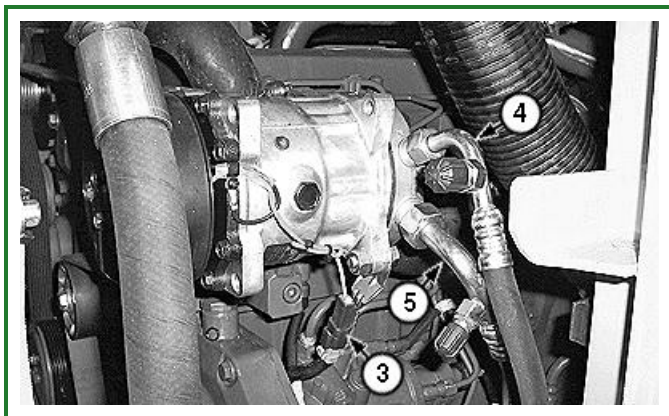

TX1005151A-UN: Compressor

LEGEND:

- 3 - Wiring Harness
- 4 - Suction Hose
- 5 - Discharge Hose

Disconnect wiring harness (3), suction hose (4) and discharge hose (5).

3.

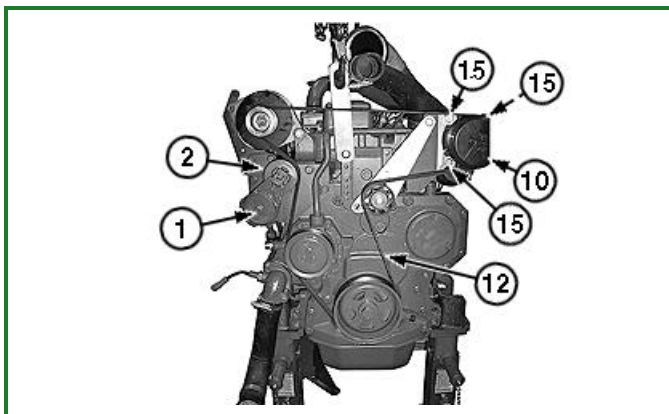

TX1005148A-UN: Belt

LEGEND:

- 1 - Screw

- 2 - Tensioner
- 10 - Compressor
- 12 - Adjuster Belt
- 15 - Cap Screw

Loosen screw (1) and tensioner (2) to remove adjuster belt (12).

4. Remove three cap screws (15) and compressor (10).
5. Install compressor and tighten cap screws.
6. Connect suction hose, discharge hose and wiring harness.
7. Install belt.
8. Install new receiver-dryer. [See Receiver-Dryer Remove and Install](#) . (Group 1830.)
9. Evacuate and charge the air conditioning system. [See Evacuate R134a System](#) and [see Charge R134a System](#) . (Group 1830.)

IMPORTANT:

When turning air conditioning on for the first time, set the engine rpm at slow idle to avoid possible high pressure discharge of extra refrigerant oil that is in all new compressors.

Go to [Section_18:Group_1830](#)

CED, TX03399, 5020-19-20091216

Compressor Remove and Install

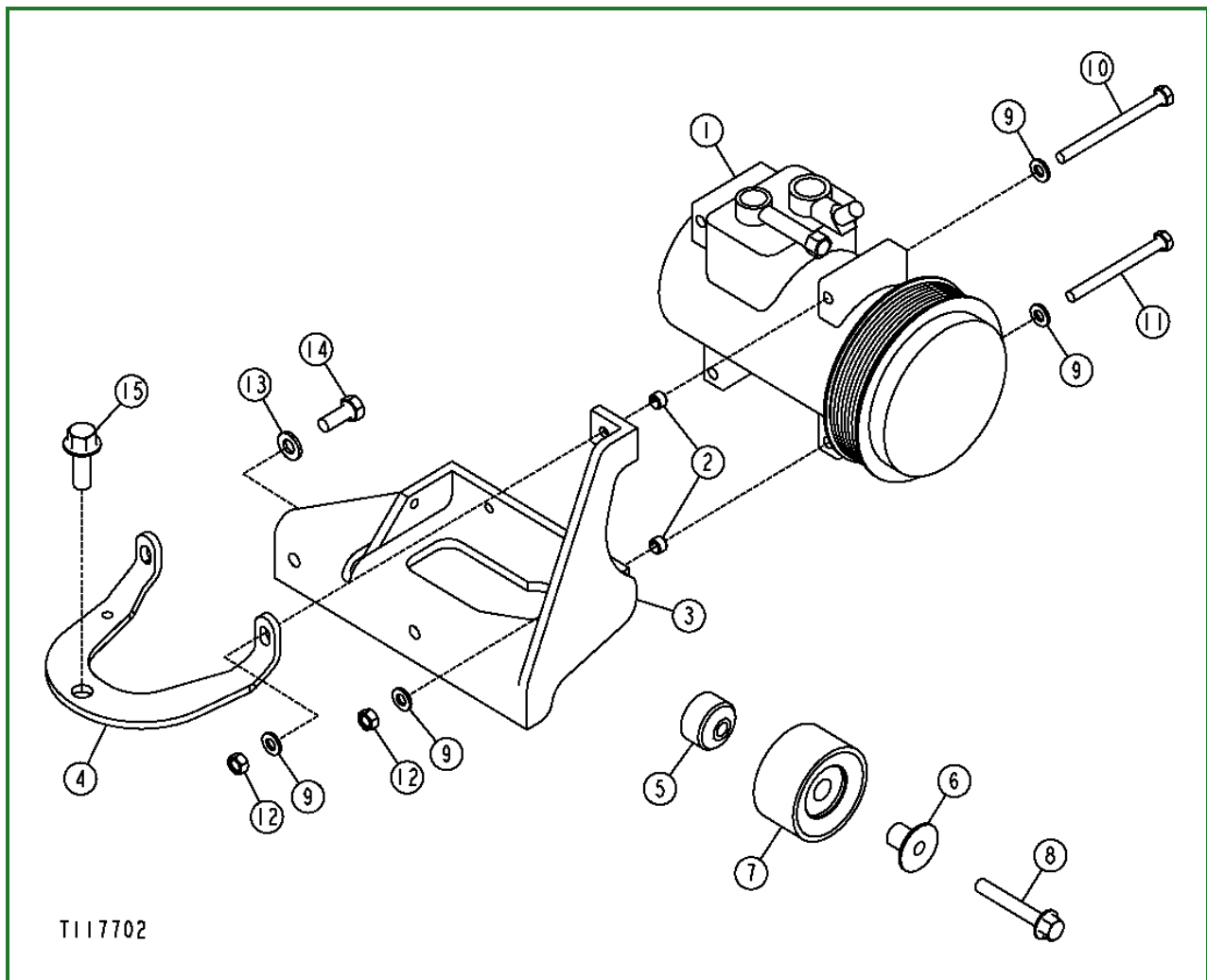

T117702-UN: Compressor and Bracket

LEGEND:

- 1 - Compressor
- 2 - Spring Pin (2 used)
- 3 - Bracket
- 4 - Support
- 5 - Spacer
- 6 - Sleeve
- 7 - Pulley
- 8 - Cap Screw
- 9 - Washer (6 used)
- 10 - Cap Screw
- 11 - Cap Screw (3 used)
- 12 - Nut (3 used)
- 13 - Washer (2 used)
- 14 - Cap Screw (2 used)
- 15 - Cap Screw

1. Remove refrigerant from the system. [See Recover R134a Refrigerant](#) . (Group 1830.)
2. Loosen belt adjuster and remove belt
3. Disconnect wiring lead, suction and discharge lines.

4. Remove four cap screws and compressor.
5. Repair or replace compressor. [See Compressor Disassemble and Assemble](#) . (Group 1830)
6. Install compressor and tighten cap screws.

Item	Measurement	Specification
Compressor-to-Bracket Cap Screws	Torque	35 N·m 26 lb-ft
Support Bracket-to-Engine Block Cap Screws	Torque	120 N·m 89 lb-ft
Compressor Bracket-to-Engine Block Cap Screws	Torque	70 N·m 52 lb-ft
Idler Pulley-to-Fan Drive Cap Screws	Torque	50 N·m 37 lb-ft

7. Connect suction and discharge lines and wiring lead.
8. Install belt.
9. Install new receiver-dryer.
10. Evacuate and charge the air conditioning system. [See Evacuate R134a System](#) and [see Charge R134a System](#) . (Group 1830.)

IMPORTANT:

When turning air conditioning on for the first time, set the engine rpm at slow idle to avoid possible high pressure discharge of extra refrigerant oil that is in all new compressors.

Go to [Section_18:Group_1830](#)

KV70328,000007B-19-20081210

Compressor Clutch Disassemble and Assemble

1.

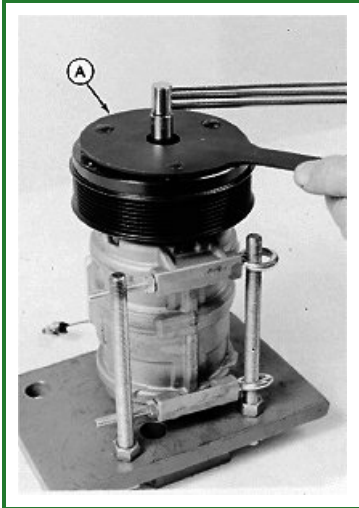

RW21157-UN: Using DFTW20 To Mount Compressor

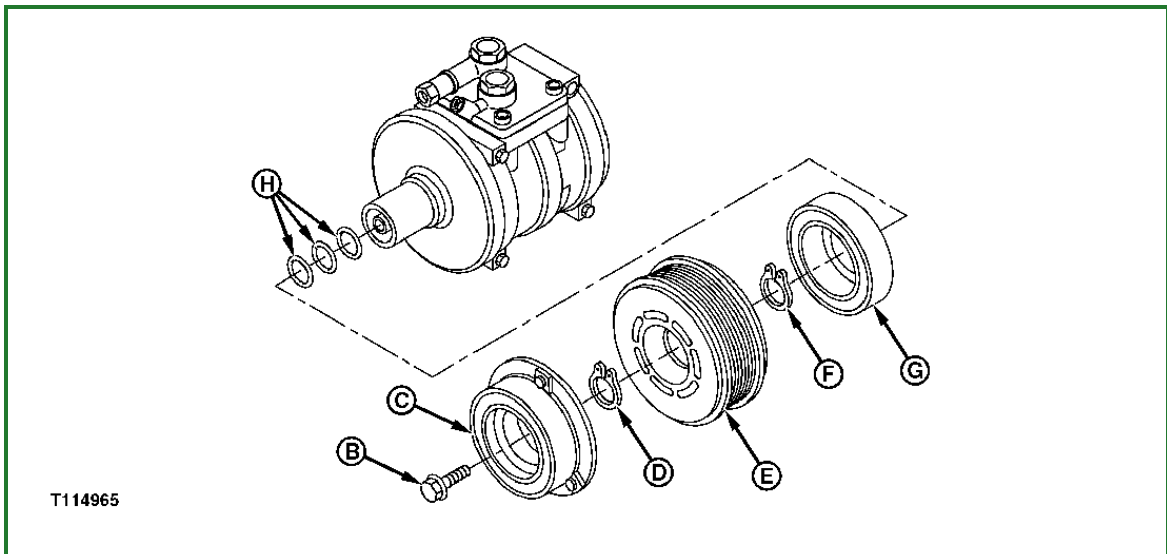

T114965-UN: R134a Compressor Clutch Exploded View

LEGEND:

- A - JDG747 Compressor Clutch Spanner
- B - Clutch Shaft Bolt
- C - Clutch Hub
- D - Pulley Snap Ring
- E - Pulley
- F - Clutch Coil Snap Ring
- G - Clutch Coil
- H - Shims

Mount compressor on D01006AA Bench Mounted Holding Fixture or DFRW20 Compressor Holding Fixture using two 6 in. x 1/4 in. eye bolts with nuts as illustrated.

2. Remove dust cover.
3. Hold the clutch hub using JDG747 Compressor Clutch Spanner (A) and remove the clutch shaft bolt (B).
4. Remove the clutch hub (C). Remove the shims (H) from the clutch hub and save for installation.

5. Remove and discard snap ring (D). Remove the pulley (E) using a plastic hammer or JDG220 Puller, JDG748 Jaws and JDG771 Forcing Screw.
6. Disconnect the clutch coil lead wire. Remove and discard the snap ring (F) and remove the clutch coil (G).

NOTE:

The bearing in the pulley is not serviceable.

7. Check pulley bearing operation. Replace pulley and bearing as required.
8. Install the clutch coil and new snap ring with flat side of the snap ring down. Connect the clutch coil lead wire.
9. Install the pulley and new snap ring with the flat side of the snap ring down. Apply grease to the shims (H) and install to the clutch hub.
10. Install clutch hub and shaft bolt and tighten.

Item	Measurement	Specification
Compressor Hub Retaining Nut	Torque	14 N·m 124 lb-in.

Go to [Section_18:Group_1830](#)

TX,18,RB761-19-20060317

Clutch Hub Clearance Check

NOTE:

The clutch coil is not polarity sensitive.

1.



RW21159-UN: Using A Dial Indicator To Check Clearance

Check pulley-to-clutch hub clearance using a dial indicator. Mount the gauge to the pulley as illustrated and connect a set of jumper wires from the compressor to a 12V battery.

2. Rotate the pulley and check clearance in three equally spaced locations around the clutch hub. Add or remove shims to obtain specified clearance.

Item	Measurement	Specification
Air Conditioning Clutch Hub-to-Pulley Clearance		0.35—0.65 mm 0.014—0.026 in.

3. Tighten clutch shaft bolt to specification after correct clearance is obtained.

Item	Measurement	Specification
Air Conditioning Clutch Shaft Bolt Torque		14 N·m 124 lb-in.

Go to [Section_18:Group_1830](#)

TX,18,RB762-19-20060317

Compressor Manifold Inspect

1.

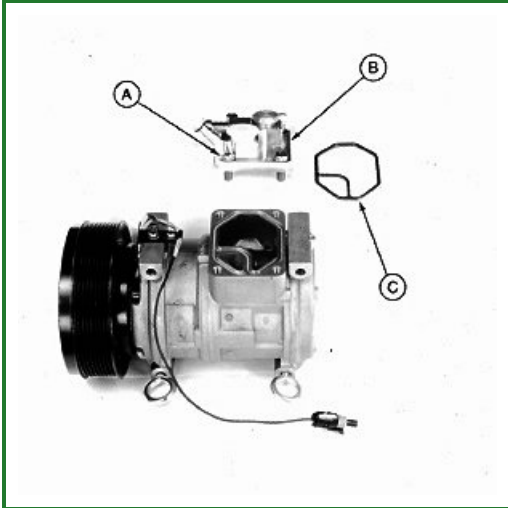

RW21160-UN: R134a Compressor Manifold and Cap Screws

LEGEND:

A - Manifold Cap Screw

B - Manifold

C - Manifold Seal

Remove cap screws (A) and the manifold (B).

2. Remove and discard seal (C). Inspect porting surfaces.

3. Lubricate and install a new seal (C).

4. Install manifold and tighten cap screws.

Item	Measurement	Specification
Manifold Through Bolt Torque		26 N·m 230 lb-in

Go to [Section_18:Group_1830](#)

TX,18,RB763-19-20060417

Compressor Disassemble and Assemble

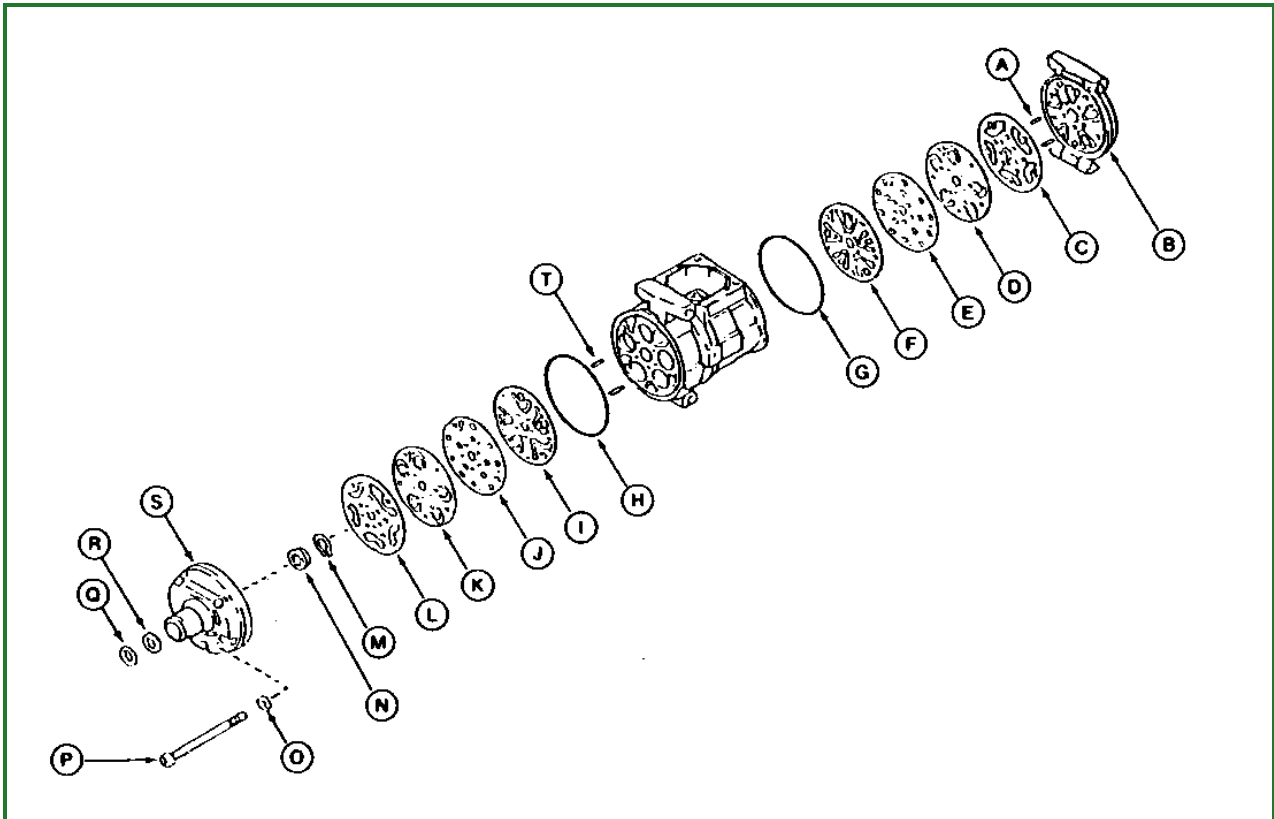

RW21161-UN: Exploded View of R134a Compressor

LEGEND:

- A - Rear Pins
- B - Rear Housing
- C - Rear Gasket
- D - Rear Discharge Reed Valve
- E - Rear Valve Plate
- F - Rear Suction Reed Valve
- G - Rear O-Ring
- H - Front O-Ring
- I - Front Suction Reed Valve
- J - Front Valve Plate
- K - Front Discharge Reed Valve
- L - Front Gasket
- M - Snap Ring
- N - Lip Seal
- O - Washer
- P - Through Bolt
- Q - Felt Holder
- R - Felt
- S - Front Housing
- T - Front Pins

1.



RW21162-UN: Installing A New Lip Seal With A Socket

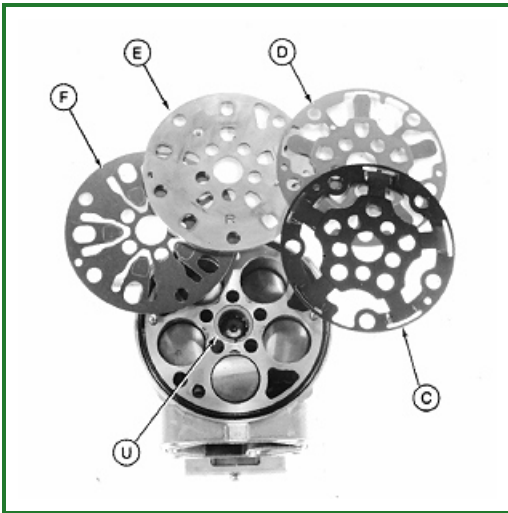

RW21163-UN: Gasket and Valve Plate Assembly

LEGEND:

- C - Rear Gasket
- D - Rear Discharge Reed Valve
- E - Rear Valve Plate
- F - Rear Suction Reed Valve
- U - Pump Body

Clean the compressor using solvent before disassembly. Mount compressor on holding fixture and remove clutch. [See Compressor Clutch Disassemble and Assemble](#) . (Group 1830.)

2. **IMPORTANT:**

When removing front and rear housing, be careful not to damage the sealing surfaces.

Disassemble the compressor as illustrated and discard the O-rings, gaskets, lip seal, snap ring, and through bolt washers. Replace parts from service kits.

NOTE:

*The valve plates, reed valves, cylinders, and cylinder housings are not serviceable.
Some cylinder scuffing (light scratches) is normal.*

3. Inspect the valves for an even wear pattern and the cylinders for scoring or excessive wear. Replace compressor as required.

4. Remove the shaft seal snap ring (M). Turn the housing over and remove the felt holder (Q) and felt (R) from the front housing (S).
5. Remove the shaft lip seal (N) from the front housing (S) using a small tool with 5/8 in. OD.
6. Wash all parts in clean solvent and dry before assembly.
7. IMPORTANT:

Lubricate O-rings, gaskets, and lip seal using only TY22025 (R134a) refrigerant oil during assembly. Other oils could damage the compressor.

Apply R134a oil to the bore of the front housing and install new lip seal (N) to the bottom of the bore using a socket. Install new snap ring (M) flat side down.

8. IMPORTANT:

Bushing spacer (U) must be in position before assembling the compressor.

Install pins (A) and new O-ring (G) in the rear cylinder.

NOTE:

The rear valve plate is marked with an "R" and is installed face up.

9. Install parts (F—D) over the pins on the rear cylinder.
10. Install a new gasket (C) flat side down and the rear housing (B) on the rear cylinder. Mount the compressor onto the holding fixture.
11. Install pins (T) and new O-ring (H) in the front cylinder.

NOTE:

The front valve plate is marked with an "F" and is installed face up.

12. Install parts (I—K) over the pins on the front cylinder.
13. Install a new gasket (L) flat side down. Put JDG746 lip seal protector on the shaft and lubricate with R134a oil.
14. Install the front housing (S) on the front cylinder and remove the lip seal protectors. Install through bolts (P) and new washers (O).
15. Partially tighten the through bolts and then tighten to specification.

Item	Measurement	Specification
Air Conditioning Compressor Through Bolt	Torque	26 N·m 230 lb-in.

16. Install the felt (R) and felt holder (Q) using the clutch hub.
17. Install the pulley-clutch hub and check clearance. [See Clutch Hub Clearance Check](#) . (Group 1830.)

Go to [Section_18:Group_1830](#)

TX,18,RB764-19-20060317

Section 19: Sheet Metal and Styling

Group 1910: Hood and Engine Enclosure

Hood Remove and Install

Hood Support and Engine Side Shields Remove and Install

Group 1921: Grille and Grille Housing

Grille and Grille Housing Removal

Grille and Grille Housing Installation

Hood Remove and Install

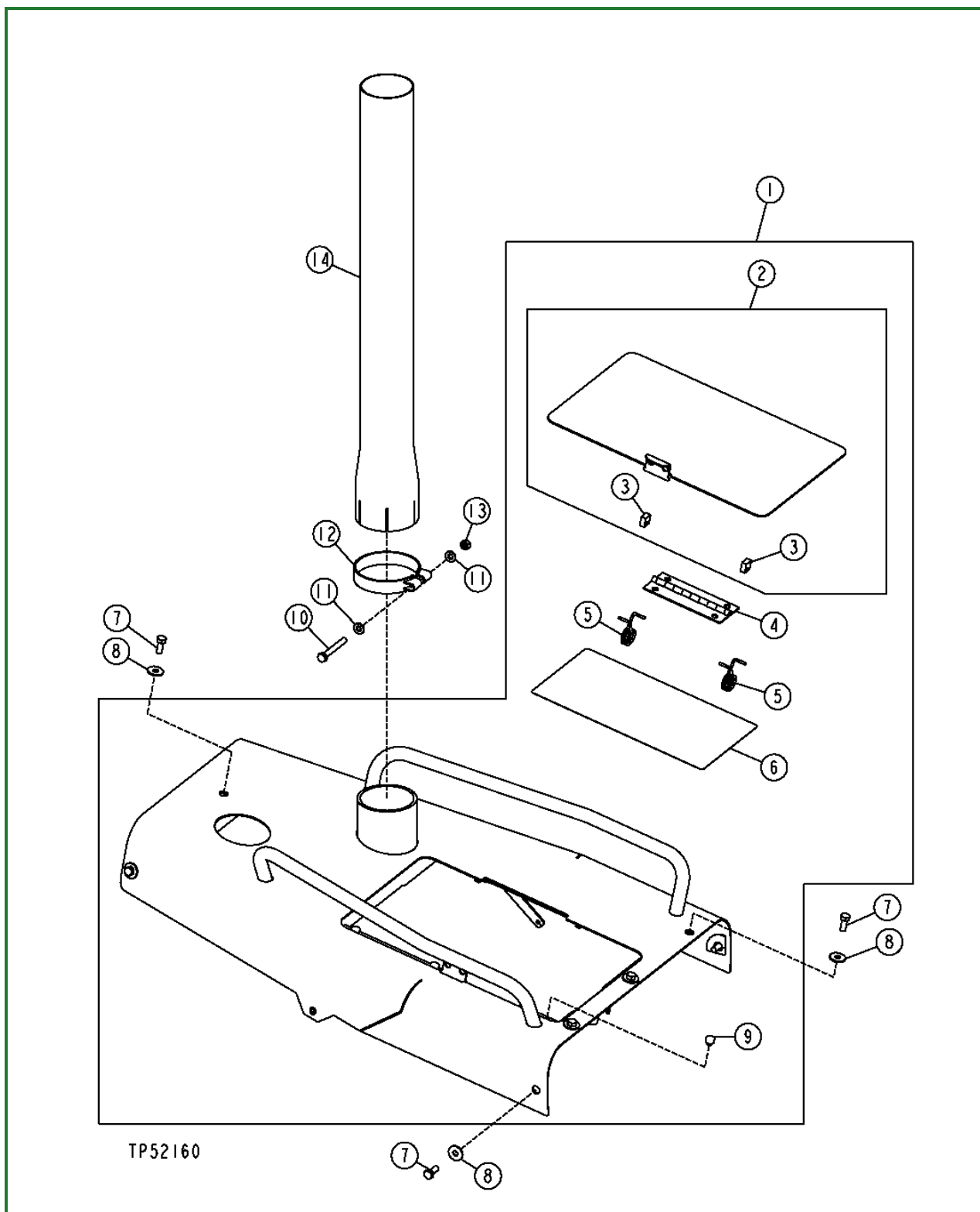

TP52160-UN: Hood

LEGEND:

- 1 - Hood Assembly
- 2 - Door
- 3 - Strap (4 used)
- 4 - Hinge
- 5 - Spring (2 used)
- 6 - Label
- 7 - Cap Screw (8 used)
- 8 - Washer (8 used)

- 9 - Bumper (3 used)
- 10 - Cap Screw
- 11 - Washer (2 used)
- 12 - Clamp
- 13 - Nut
- 14 - Extension

1. Remove engine side shields.
2. Disconnect wires on horn.
3. Disconnect oil fill tube clamp from hood (550J and 650J only).

4.

⚠ CAUTION:

Prevent possible crushing injury from removing hood. Use proper lifting equipment and safety precautions.

Item	Measurement	Specification
Hood Weight		30 kg 66 lb

Install strap and hoist.

5. Remove hood.
6. Remove parts as necessary.
7. Install hood. Tighten cap screws.
8. Connect ground wire on horn and install engine side shields.

Go to [Section_19:Group_1910](#)

CED,TX03399,5001-19-19990416

Hood Remove and Install

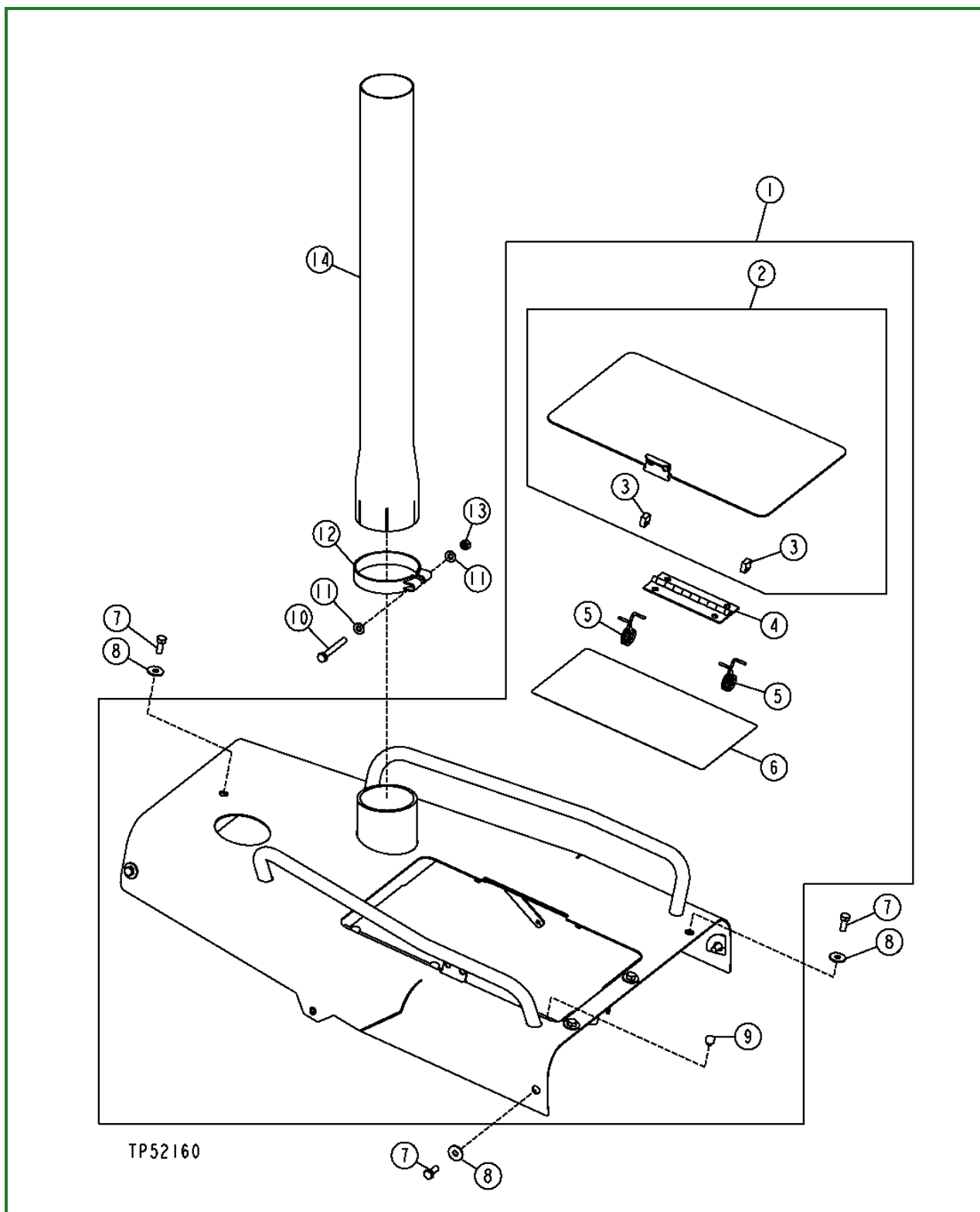

TP52160-UN: Hood

LEGEND:

- 1 - Hood Assembly
- 2 - Door
- 3 - Strap (4 used)
- 4 - Hinge
- 5 - Spring (2 used)
- 6 - Label
- 7 - Cap Screw (8 used)
- 8 - Washer (8 used)

- 9 - Bumper (3 used)
- 10 - Cap Screw
- 11 - Washer (2 used)
- 12 - Clamp
- 13 - Nut
- 14 - Extension

1. Remove engine side shields.
2. Disconnect wires on horn.
3. Disconnect oil fill tube clamp from hood (550J and 650J only).

4.

⚠ CAUTION:

Prevent possible crushing injury from removing hood. Use proper lifting equipment and safety precautions.

Item	Measurement	Specification
Hood Weight		30 kg 66 lb

Install strap and hoist.

5. Remove hood.
6. Remove parts as necessary.
7. Install hood. Tighten cap screws.
8. Connect ground wire on horn and install engine side shields.

Go to [Section_19:Group_1910](#)

CED,TX03399,5001-19-19990416

Hood Support and Engine Side Shields Remove and Install

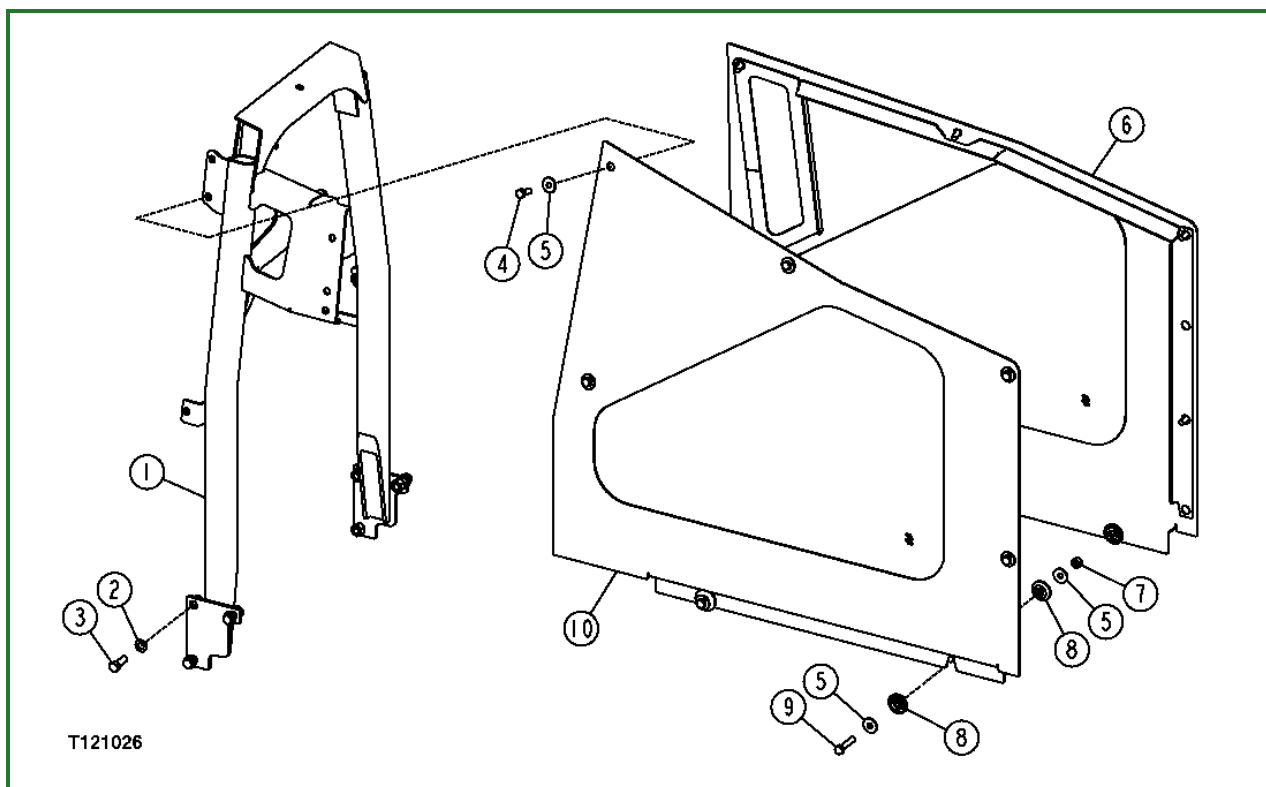

T121026-UN: Hood Support and Engine Side Shields

LEGEND:

- 1 - Hood Support
- 2 - Washer (6 used)
- 3 - Cap Screw (6 used)
- 4 - Cap Screw (10 used)
- 5 - Washer (18 used)
- 6 - Shield (Left Engine Side)
- 7 - Nut (4 used)
- 8 - Guide (8 used)
- 9 - Cap Screw (4 used)
- 10 - Shield (Right Engine Side)

1. Remove and install when necessary.
2. Tighten cap screws.

Go to [Section_19:Group_1910](#)

CED,OUTX547,184-19-19990416

Grille and Grille Housing Removal

1.

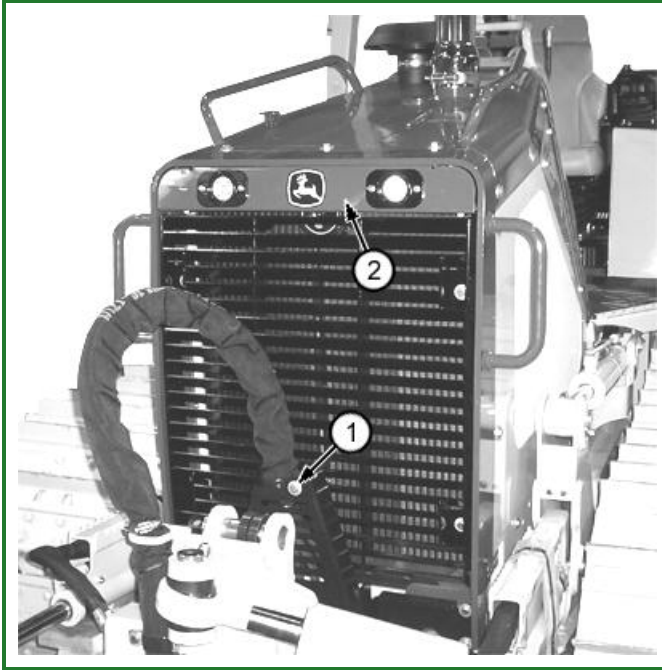

T199714A-UN: Standard Grille

LEGEND:

1 - Cap Screw

2 - Head Lights and Panel

Lower all equipment to the ground. Operate hydraulic controls to relieve pressure in the system.

2. Remove cap screw (1) and pull hoses away from grille.

3.

⚠ CAUTION:

Prevent possible crushing injury from removing grille. Use proper lifting equipment and safety precautions.

Item	Measurement	Specification
Grille		
450J Standard Grille	Weight	22.8 kg 50 lb
550J and 650J Standard Grille	Weight	28 kg 62 lb
450J Heavy Duty Grille	Weight	52.4 kg 116 lb
550J and 650J Heavy Duty Grille	Weight	64 kg 141 lb

Connect grille to hoist. Remove cap screws and remove grille.

4. Disconnect head light wire connectors and remove head lights and panel (2).

5.

⚠ CAUTION:

Prevent possible crushing injury from removing hood. Use proper lifting equipment and safety precautions.

Item	Measurement	Specification
Grille Housing		
450J Grille Housing	Weight	32 kg 71 lb
550J and 650J Grille Housing	Weight	36 kg 80 lb

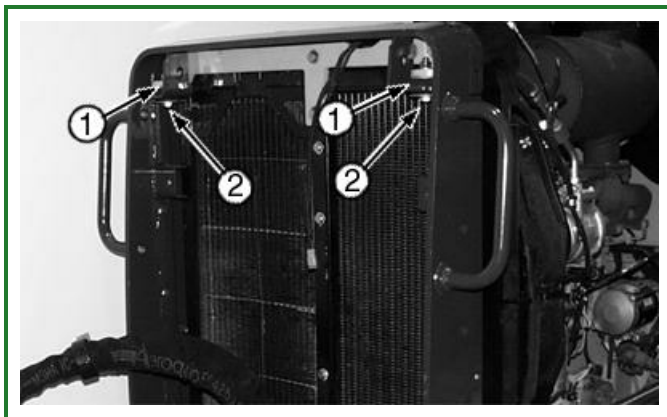

T119162B-UN: Grille Housing Mounts

LEGEND:

- 1 - Rubber Mounts (2 used)
- 2 - Radiator/Oil Cooler-to-Grille Housing Cap Screw (2 used)

Connect grille housing to hoist, using lifting straps around handles.

6. Remove radiator/oil cooler-to-grille housing cap screws (2).
7. Remove rubber mounts (1).

8.

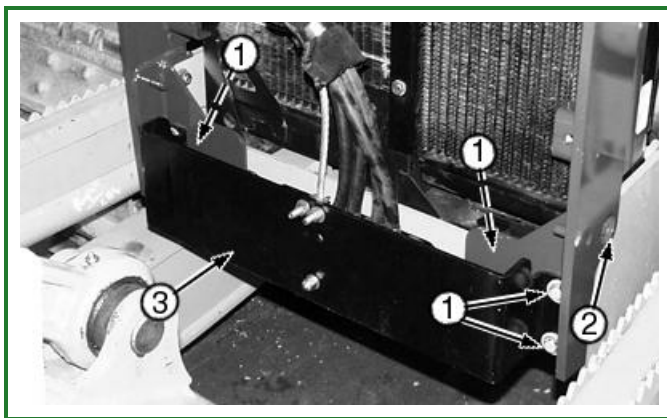

T119187B-UN: Standard Grille Hose Guard

LEGEND:

- 1 - Cap Screw (6 used)
- 2 - Cap Screw (2 used)
- 3 - Hose Guard

Remove cap screws (1), allowing hose guard (3) to hang.

9. Remove cap screws (2) from grille housing.
10. Remove grille housing.

Go to [Section_19:Group_1921](#)

CED, TX03399,5002-19-20090729

Grille and Grille Housing Removal

1.

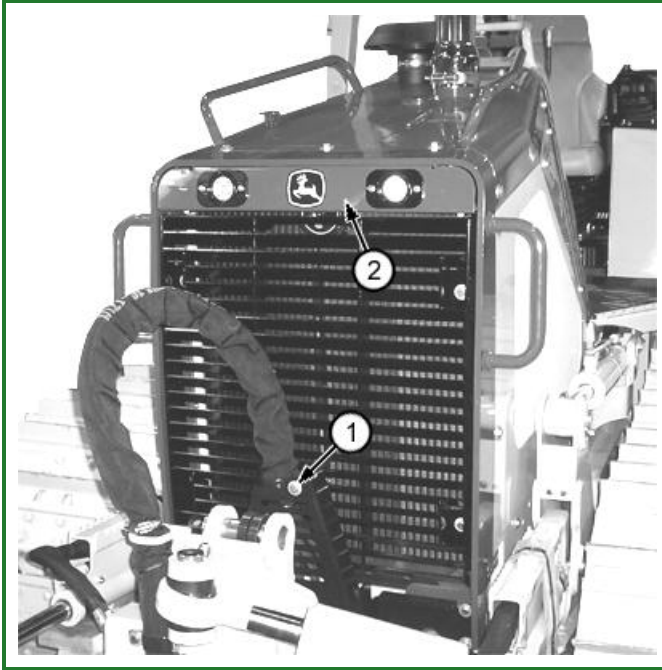

T199714A-UN: Standard Grille

LEGEND:

1 - Cap Screw

2 - Head Lights and Panel

Lower all equipment to the ground. Operate hydraulic controls to relieve pressure in the system.

2. Remove cap screw (1) and pull hoses away from grille.

3.

⚠ CAUTION:

Prevent possible crushing injury from removing grille. Use proper lifting equipment and safety precautions.

Item	Measurement	Specification
Grille		
450J Standard Grille	Weight	22.8 kg 50 lb
550J and 650J Standard Grille	Weight	28 kg 62 lb
450J Heavy Duty Grille	Weight	52.4 kg 116 lb
550J and 650J Heavy Duty Grille	Weight	64 kg 141 lb

Connect grille to hoist. Remove cap screws and remove grille.

4. Disconnect head light wire connectors and remove head lights and panel (2).

5.

⚠ CAUTION:

Prevent possible crushing injury from removing hood. Use proper lifting equipment and safety precautions.

Item	Measurement	Specification
Grille Housing		
450J Grille Housing	Weight	32 kg 71 lb
550J and 650J Grille Housing	Weight	36 kg 80 lb

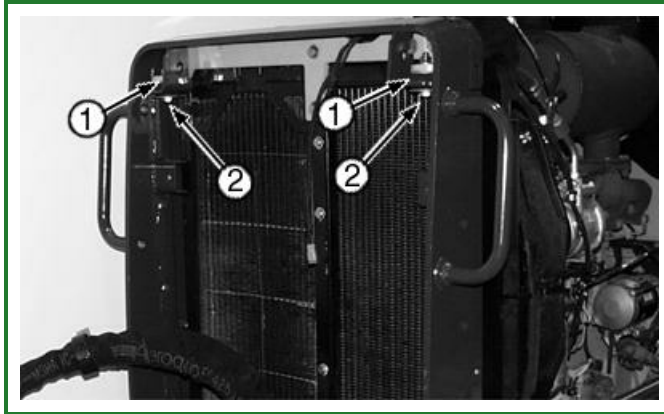

T119162B-UN: Grille Housing Mounts

LEGEND:

- 1 - Rubber Mounts (2 used)
- 2 - Radiator/Oil Cooler-to-Grille Housing Cap Screw (2 used)

Connect grille housing to hoist, using lifting straps around handles.

6. Remove radiator/oil cooler-to-grille housing cap screws (2).
7. Remove rubber mounts (1).

8.

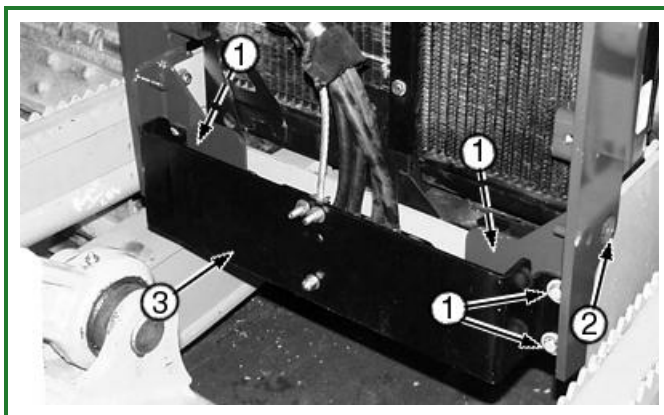

T119187B-UN: Standard Grille Hose Guard

LEGEND:

- 1 - Cap Screw (6 used)
- 2 - Cap Screw (2 used)
- 3 - Hose Guard

Remove cap screws (1), allowing hose guard (3) to hang.

9. Remove cap screws (2) from grille housing.
10. Remove grille housing.

Go to [Section_19:Group_1921](#)

CED, TX03399,5002-19-20090729

Grille and Grille Housing Installation

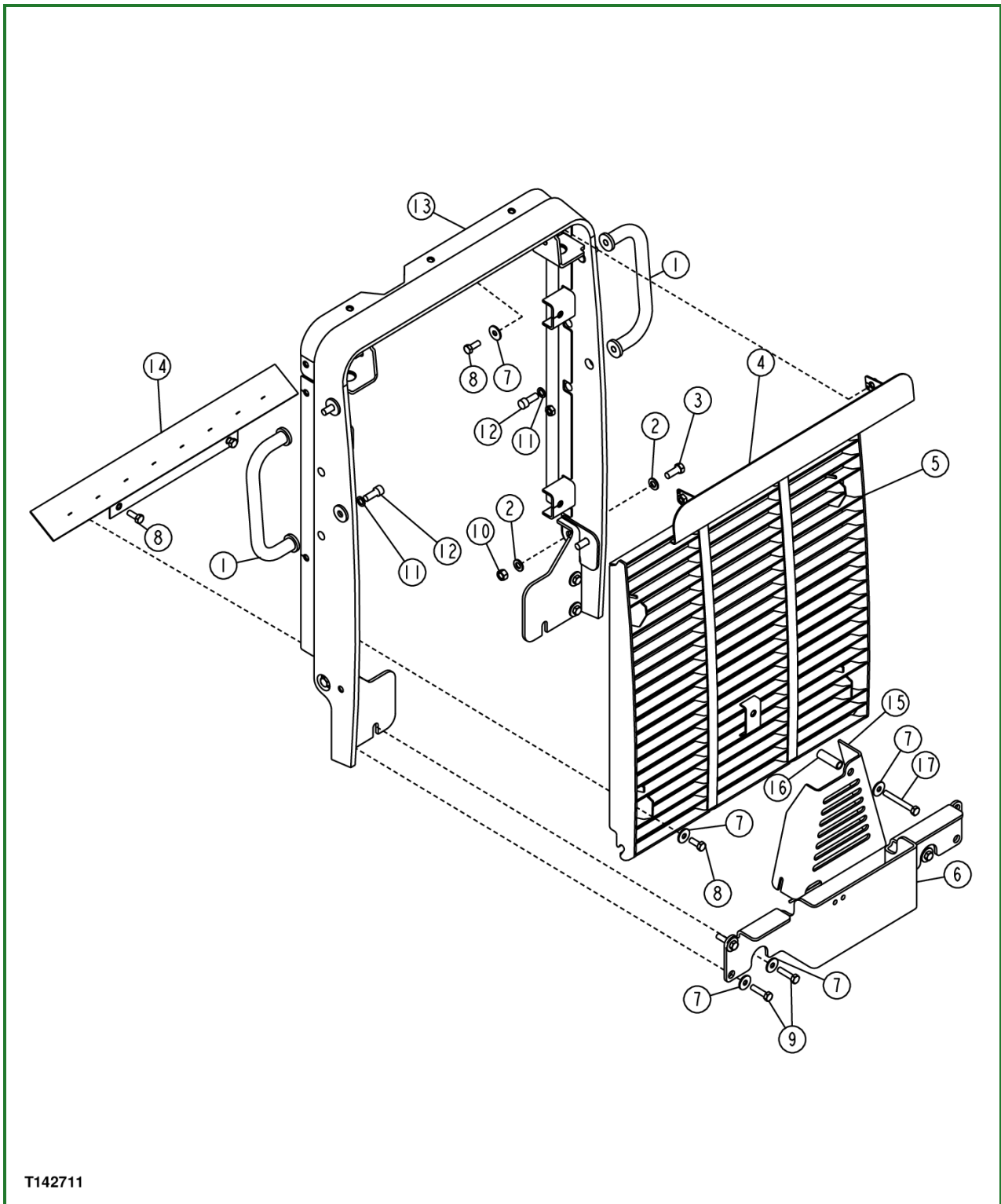

T142711-UN: Standard Grille and Grille Housing

LEGEND:

- 1 - Handle (2 used)
- 2 - Washer (4 used)
- 3 - Cap Screw (2 used)
- 4 - Head Light Plate
- 5 - Grille
- 6 - Hose Guard
- 7 - Washer (12 used)
- 8 - Cap Screw (8 used)

- 9 - Cap screw (6 used)
- 10 - Nut (2 used)
- 11 - Washer (4 used)
- 12 - Screw (4 used)
- 13 - Grille Frame
- 14 - Shield
- 15 - Hose Guard
- 16 - Spacer
- 17 - Cap Screw

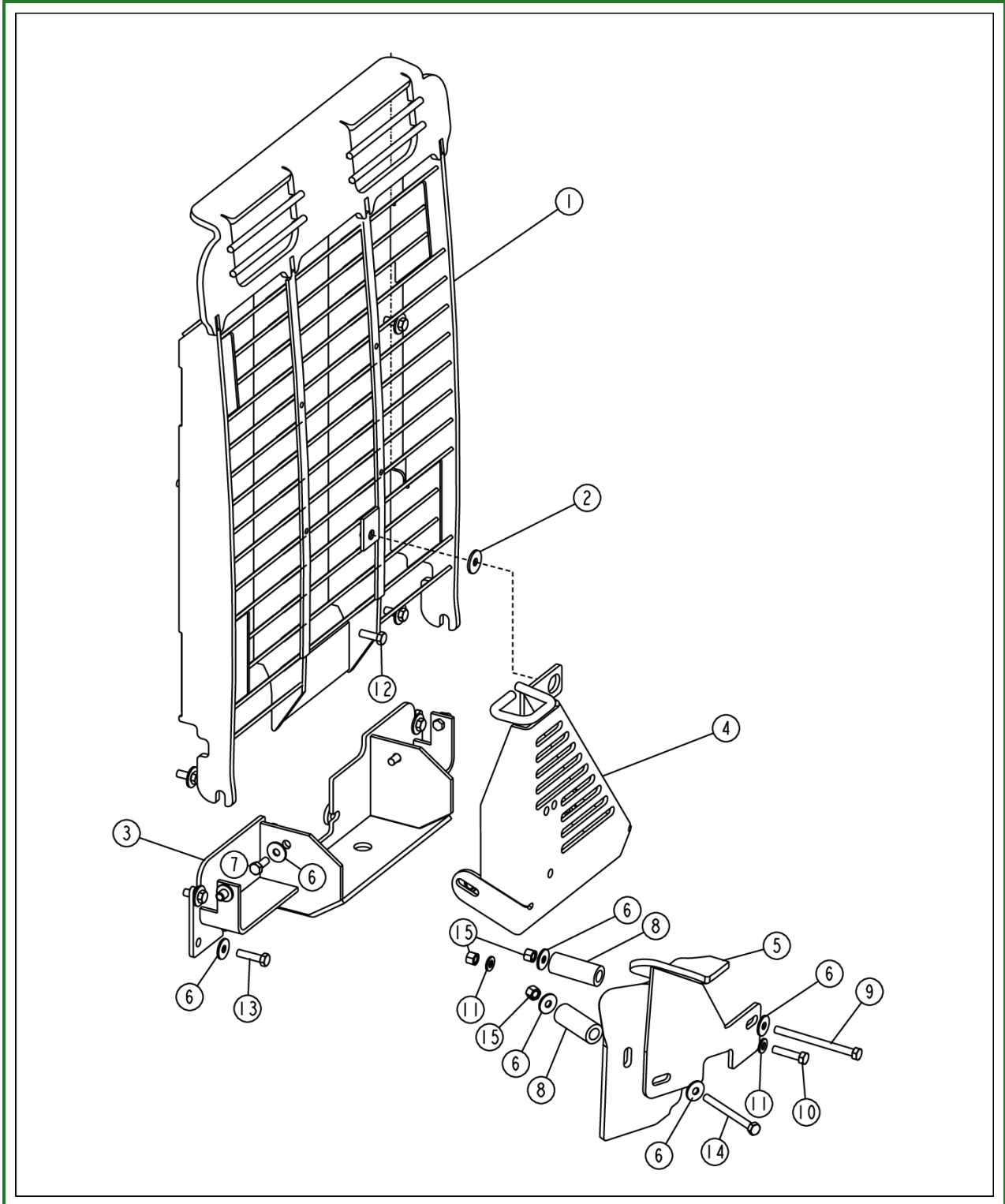

T142712-UN: Heavy Duty Grille and Grille Housing

LEGEND:

1 - Grille

- 2 - Washer
- 3 - Hose Guard
- 4 - Hose Guard
- 5 - Hose Guard
- 6 - Washer (6 used)
- 7 - Cap Screw (8 used)
- 8 - Bushing (2 used)
- 9 - Cap Screw
- 10 - Cap Screw
- 11 - Washer (2 used)
- 12 - Cap Screw
- 13 - Cap Screw (4 used)
- 14 - Cap Screw
- 15 - Lock Nut (3 used)

1.

⚠ CAUTION:

Prevent possible crushing injury from removing grille housing. Use proper lifting equipment and safety precautions.

Item	Measurement	Specification
Grille Housing		
450J Grille Housing	Weight	32 kg 71 lb
550J and 650J Grille Housing	Weight	36 kg 80 lb

Connect grille housing to hoist using lifting straps around handles.

2. Install grille housing and upper rubber mounts. Tighten cap screws to specification.

Item	Measurement	Specification
Upper Radiator/Oil Cooler Bracket-to-Grill Housing Cap Screws	Torque	58 N·m 43 lb-ft

3. Install hose guards. Tighten cap screws to specification.

Item	Measurement	Specification
Grille Housing Cap Screws	Torque	73 N·m 54 lb-ft

4. Connect head light wire connectors and install head light plate.

5.

⚠ CAUTION:

Prevent possible crushing injury from removing grille. Use proper lifting equipment and safety precautions.

Item	Measurement	Specification
Grille		
450J Standard Grille	Weight	22.8 kg 50 lb
550J and 650J Standard Grille	Weight	28 kg 62 lb
450J Heavy Duty Grille	Weight	52.4 kg 116 lb
550J and 650J Heavy Duty Grille	Weight	64 kg 141 lb

Install grille (5) and connect hoses to grille.

Go to [Section_19:Group_1921](#)

CED, TX03399, 5003-19-20010607

Section 21: Main Hydraulic System

Group 2160: Hydraulic System

Hydraulic Pump Remove and Install

Hydraulic Pump (With Winch Option) Disassemble and Assemble

Hydraulic Pump (Without Winch Option) Disassemble and Assemble

Hydraulic Reservoir Remove and Install

Hydraulic Reservoir and Hydrostatic Reservoir Cleanout Cover Remove and Install

Hydraulic Reservoir Disassemble and Assemble

Hydraulic Filter Remove and Install

Hydraulic Filter Disassemble and Assemble

Hydraulic Pump Remove and Install



T116758B-UN: Seat Base Cap Screws

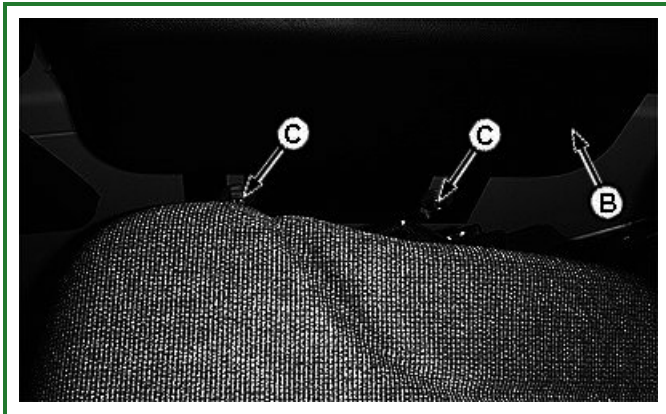

T116757B-UN: Seat Armrest Cap Screws

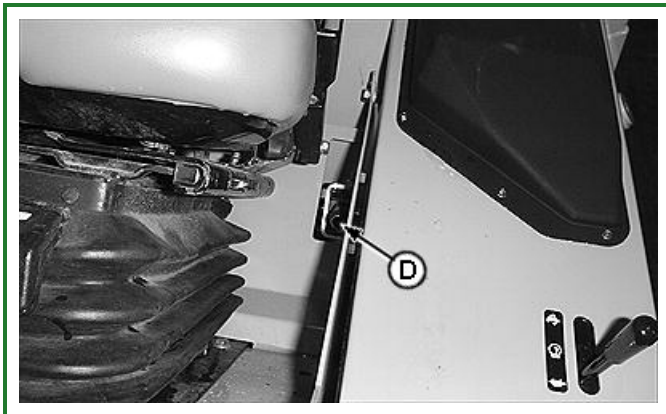

T116728B-UN: Jack Screw

LEGEND:

A - Cap Screw (4 used)

B - Armrest

C - Shoulder Cap Screw (2 used)

D - Jack Screw

E - Knee Pad

1. Lower all equipment to ground.
2. Stop engine and relieve hydraulic system pressure.
3. Turn battery disconnect switch to OFF.

4.

NOTE:

Applying vacuum to hydrostatic reservoir will help reduce leaking of hydrostatic oil from hydrostatic case drain lines once hydraulic pump is removed.

Apply vacuum to hydrostatic reservoir.

5. Drain Hydraulic Reservoir.

Item	Measurement	Specification
Hydraulic Reservoir Capacity		32 L 8.5 gal

6. If equipped with heater, drain engine coolant.

Item	Measurement	Specification
Engine Coolant Capacity		11.3 L 3 gal

7. Remove floor mat and floor access plate.

8. For machines with toolbox, pull out drawer and remove cap screw holding toolbox in place. Remove toolbox from machine.

9. Remove four cap screws (A).

10. Remove shoulder cap screws (C) from seat box under armrest (B) on both sides of seat.

11. Remove two cap screws from knee pad (E) on both sides of seat.

12. Tilt seat up as far as possible with jack screw (D) located in left rear corner of seat box.

13.

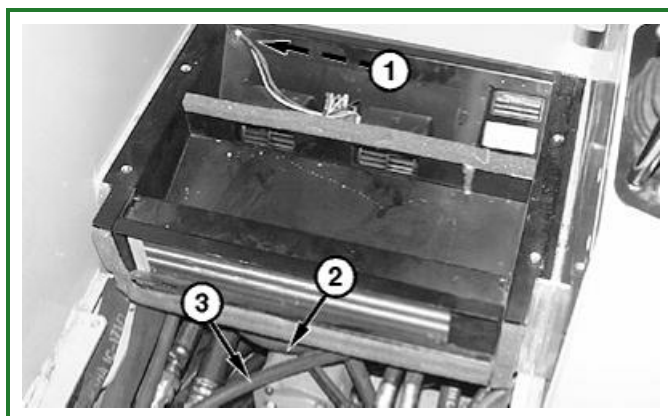

T118838B-UN: Heater

LEGEND:

1 - Blower Harness Connector

2 - Heater Hose

3 - Heater Hose

Disconnect blower harness connector (1) and heater hoses (2 and 3)

14. Remove heater assembly, If equipped.

15.

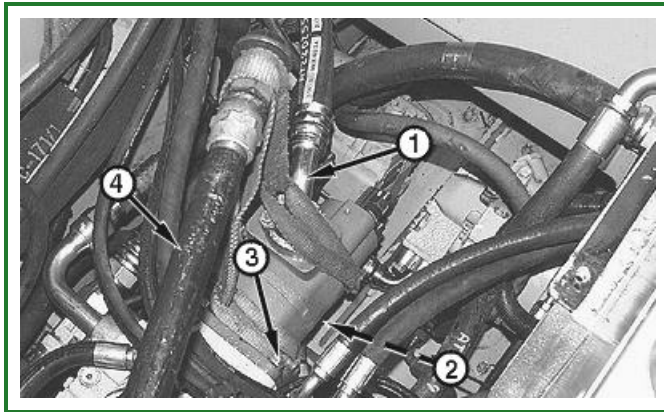

T119661B-UN: Hydraulic Pump

LEGEND:

- 1 - Hydraulic Pump-to-Reservoir Hydraulic Hose
- 2 - Hydraulic Pump-to-Control Valve Inlet Hydraulic Hose
- 3 - Cap Screws (4 used)
- 4 - DFT1132 Hydrostatic Motor and Hydraulic Pump Removal and Installation tool

Disconnect hoses (1 and 2). Cap and plug all openings

16. Install a cap screw and large washer on end of DFT1132 Hydrostatic Motor and Hydraulic Pump Removal and Installation tool (4). Install lifting straps around pump.

17.

⚠ CAUTION:

Prevent possible crushing injury from removing hydraulic pump. Use proper lifting equipment and safety precautions.

Item	Measurement	Specification
Hydraulic Pump		
Hydraulic Pump Weight		23 kg 51 lb

Remove cap screws (3) and carefully remove hydraulic pump from left side of machine.

18. Install hydraulic pump and tighten cap screws to specifications.

Item	Measurement	Specification
Hydraulic Pump		
Hydraulic Pump Mounting Cap Screws	Torque	140 N·m 103 lb-ft

19. Connect hydraulic pump-to-reservoir and hydraulic pump-to-control valve inlet hydraulic hoses (1 and 2).

20. Return any hoses moved for access to original position and install tie bands.

21. Install heater and connect heater hoses, if equipped.

22. Lower seat and secure floor plate.
23. Install tool box, knee pads, and armrests.
24. Install floor access plate and floor mat.
25. Remove vacuum from hydrostatic reservoir.
26. Fill hydraulic reservoir. [See Transmission and Hydraulic Oil](#) . (Operator's Manual.)

Item	Measurement	Specification
Hydraulic Pump		
Hydraulic Reservoir Capacity		32 L 8.5 gal

27. Remove vacuum from hydrostatic reservoir.
28. Fill radiator with coolant. [See Diesel Engine Coolant](#) . (Operator's Manual.)

Item	Measurement	Specification
Hydraulic Pump		
Engine Coolant Capacity		11.3 L 3 gal

29. Turn battery disconnect switch to ON.
30. Operate machine and check for leaks.

Go to [Section_21:Group_2160](#)

JG81906,0000122-19-20130308

Hydraulic Pump Remove and Install

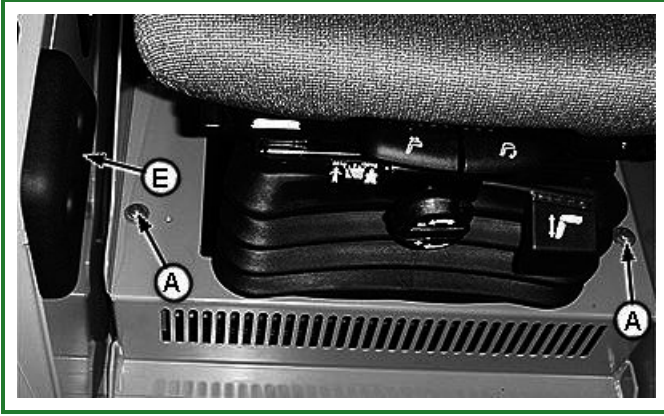

T116758B-UN: Seat Base Cap Screws

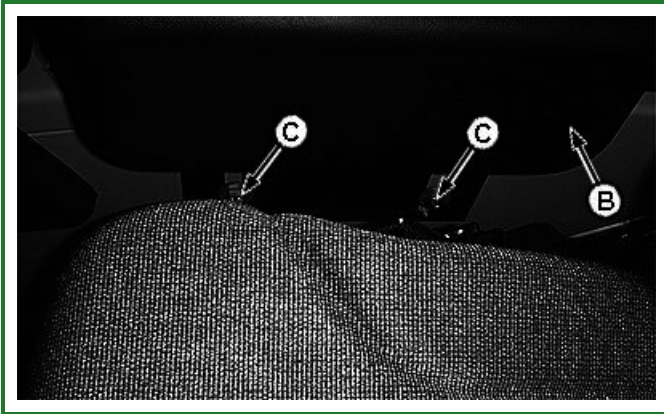

T116757B-UN: Seat Armrest Cap Screws

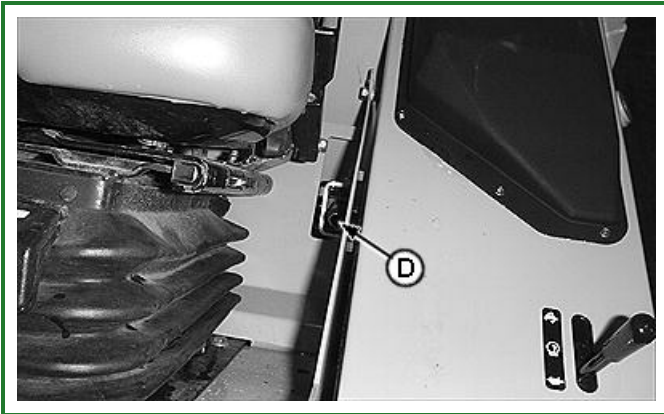

T116728B-UN: Jack Screw

LEGEND:

A - Cap Screw (4 used)

B - Armrest

C - Shoulder Cap Screw (2 used)

D - Jack Screw

E - Knee Pad

1. Lower all equipment to ground.
2. Stop engine and relieve hydraulic system pressure.
3. Turn battery disconnect switch to OFF.

4.

NOTE:

Applying vacuum to hydrostatic reservoir will help reduce leaking of hydrostatic oil from hydrostatic case drain lines once hydraulic pump is removed.

Apply vacuum to hydrostatic reservoir.

5. Drain Hydraulic Reservoir.

Item	Measurement	Specification
Hydraulic Reservoir Capacity		32 L 8.5 gal

6. If equipped with heater, drain engine coolant.

Item	Measurement	Specification
Engine Coolant Capacity		11.3 L 3 gal

7. Remove floor mat and floor access plate.

8. For machines with toolbox, pull out drawer and remove cap screw holding toolbox in place. Remove toolbox from machine.

9. Remove four cap screws (A).

10. Remove shoulder cap screws (C) from seat box under armrest (B) on both sides of seat.

11. Remove two cap screws from knee pad (E) on both sides of seat.

12. Tilt seat up as far as possible with jack screw (D) located in left rear corner of seat box.

13.

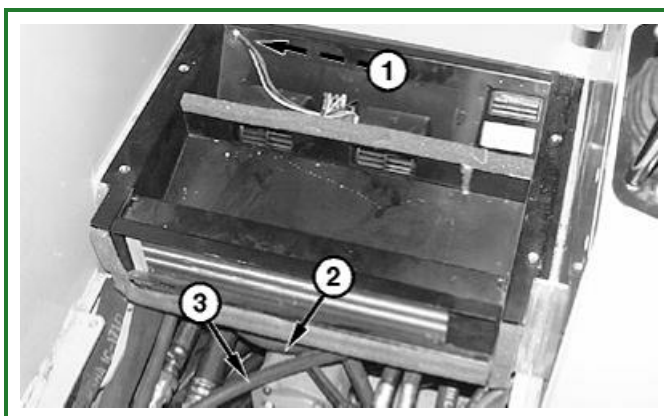

T118838B-UN: Heater

LEGEND:

1 - Blower Harness Connector

2 - Heater Hose

3 - Heater Hose

Disconnect blower harness connector (1) and heater hoses (2 and 3)

14. Remove heater assembly, If equipped.

15.

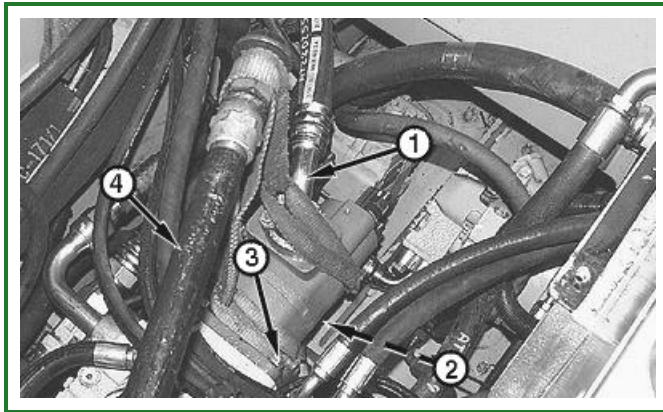

T119661B-UN: Hydraulic Pump

LEGEND:

- 1 - Hydraulic Pump-to-Reservoir Hydraulic Hose
- 2 - Hydraulic Pump-to-Control Valve Inlet Hydraulic Hose
- 3 - Cap Screws (4 used)
- 4 - DFT1132 Hydrostatic Motor and Hydraulic Pump Removal and Installation tool

Disconnect hoses (1 and 2). Cap and plug all openings

16. Install a cap screw and large washer on end of DFT1132 Hydrostatic Motor and Hydraulic Pump Removal and Installation tool (4). Install lifting straps around pump.

17.

⚠ CAUTION:

Prevent possible crushing injury from removing hydraulic pump. Use proper lifting equipment and safety precautions.

Item	Measurement	Specification
Hydraulic Pump		
Hydraulic Pump Weight		23 kg 51 lb

Remove cap screws (3) and carefully remove hydraulic pump from left side of machine.

18. Install hydraulic pump and tighten cap screws to specifications.

Item	Measurement	Specification
Hydraulic Pump		
Hydraulic Pump Mounting Cap Screws	Torque	140 N·m 103 lb-ft

19. Connect hydraulic pump-to-reservoir and hydraulic pump-to-control valve inlet hydraulic hoses (1 and 2).

20. Return any hoses moved for access to original position and install tie bands.

21. Install heater and connect heater hoses, if equipped.

22. Lower seat and secure floor plate.
23. Install tool box, knee pads, and armrests.
24. Install floor access plate and floor mat.
25. Remove vacuum from hydrostatic reservoir.
26. Fill hydraulic reservoir. [See Transmission and Hydraulic Oil](#) . (Operator's Manual.)

Item	Measurement	Specification
Hydraulic Pump		
Hydraulic Reservoir Capacity		32 L 8.5 gal

27. Remove vacuum from hydrostatic reservoir.
28. Fill radiator with coolant. [See Diesel Engine Coolant](#) . (Operator's Manual.)

Item	Measurement	Specification
Hydraulic Pump		
Engine Coolant Capacity		11.3 L 3 gal

29. Turn battery disconnect switch to ON.
30. Operate machine and check for leaks.

Go to [Section_21:Group_2160](#)

JG81906,0000122-19-20130308

Hydraulic Pump (With Winch Option) Disassemble and Assemble

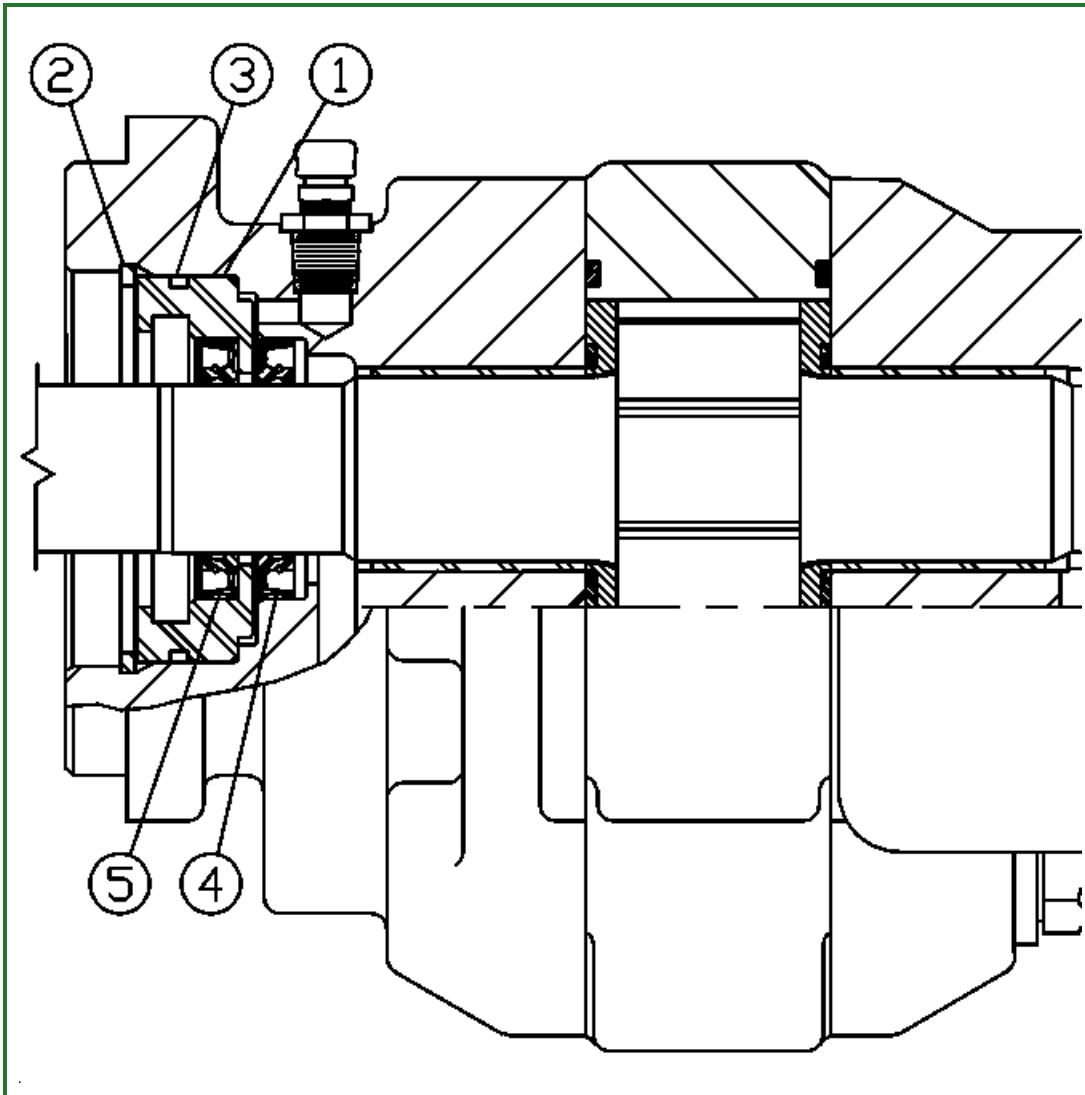
**T156546-UN: Pump Seal Assembly****LEGEND:**

- 1 - Seal Retainer
- 2 - Retainer Ring
- 3 - O-Ring
- 4 - Seal
- 5 - Seal

1. Remove retainer ring (2) and seal retainer (1).

2.

NOTE:

For replacement of input shaft seals (4—5) perform steps 1—4 only.

Remove seals (4 and 5).

3. Install seal (4) flush with face of recess in housing with lip toward gear.

4. Install seal (5) flush with counterbore seal in seal retainer (1) with lip away from gear.

5. Install O-ring (3) on seal retainer and apply petroleum jelly to lip of seals and O-ring. Install seal retainer and retainer ring.

6.

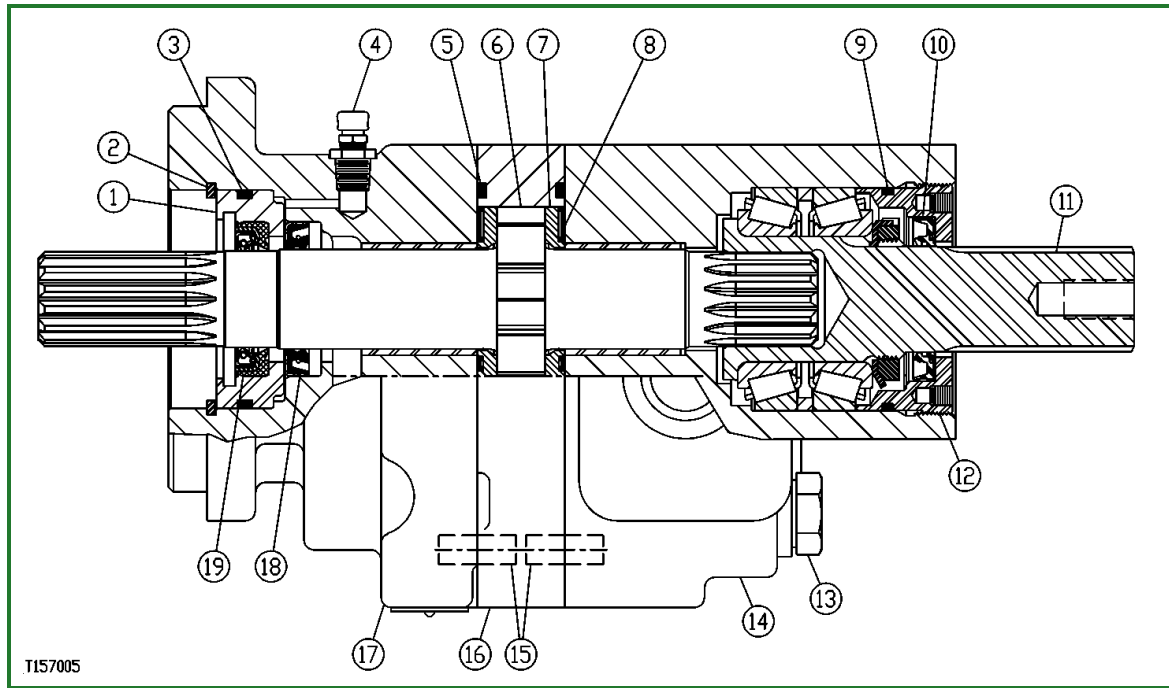

T157005-UN: Pump with Winch

LEGEND:

- 1 - Seal Retainer
- 2 - Retainer Ring
- 3 - O-Ring
- 4 - Vent
- 5 - Square Seal (2 used)
- 6 - Gear Shaft Set
- 7 - Thrust Plate (2 used)
- 8 - Channel Seal (2 used)
- 9 - O-Ring
- 10 - Seal
- 11 - Stub Shaft Assembly
- 12 - Threaded Seal Retainer
- 13 - Cap Screw
- 14 - Stub Shaft Housing
- 15 - Alignment Pin (4 used)
- 16 - Gear Housing
- 17 - Front Housing
- 18 - Seal
- 19 - Seal

Put a mark across housings (14, 16 and 17) to aid in assembly.

7. IMPORTANT:

The assembly of gear shaft set, thrust plates, and channel seals are important. For correct reassembly identify location of parts.

Remove cap screws, nuts and washers and separate housings. Remove gear shaft set (6) and thrust plates (7).

NOTE:

Gear shaft set, and pump housings are not serviceable. If any of these parts are worn or damaged, replace pump.

8.

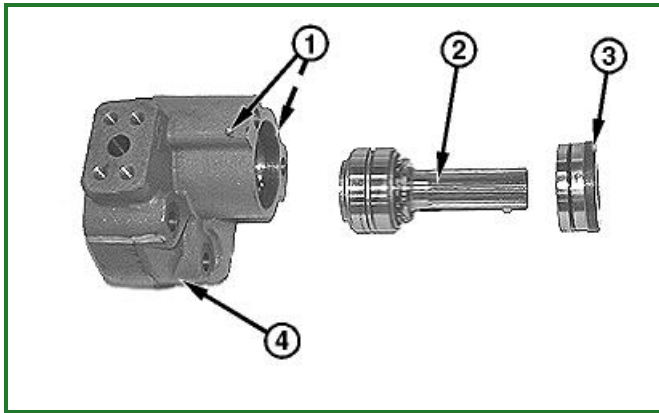

T118260B-UN: Stub Shaft Assembly

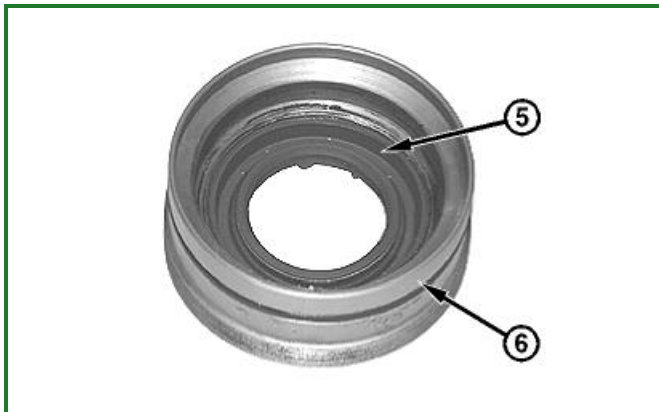

T119315B-UN: Stub Shaft Seals

LEGEND:

- 1 - Set Screws (2 used)
- 2 - Stub Shaft Assembly
- 3 - Stub Shaft Retainer
- 4 - Stub Shaft Housing
- 5 - Seal
- 6 - O-Ring

Remove set screws (1) from stub shaft housing (4).

9. Remove stub shaft retainer (3) from stub shaft housing (4).
10. Remove stub shaft assembly (2) from stub shaft housing (4) using a spanner wrench.

NOTE:

Stub shaft assembly is not serviceable. If worn or damaged, replace.

11. Inspect parts for wear or damage. Replace parts as necessary.
12. Replace seal (5) and O-ring (6) on stub shaft retainer (3).

13.

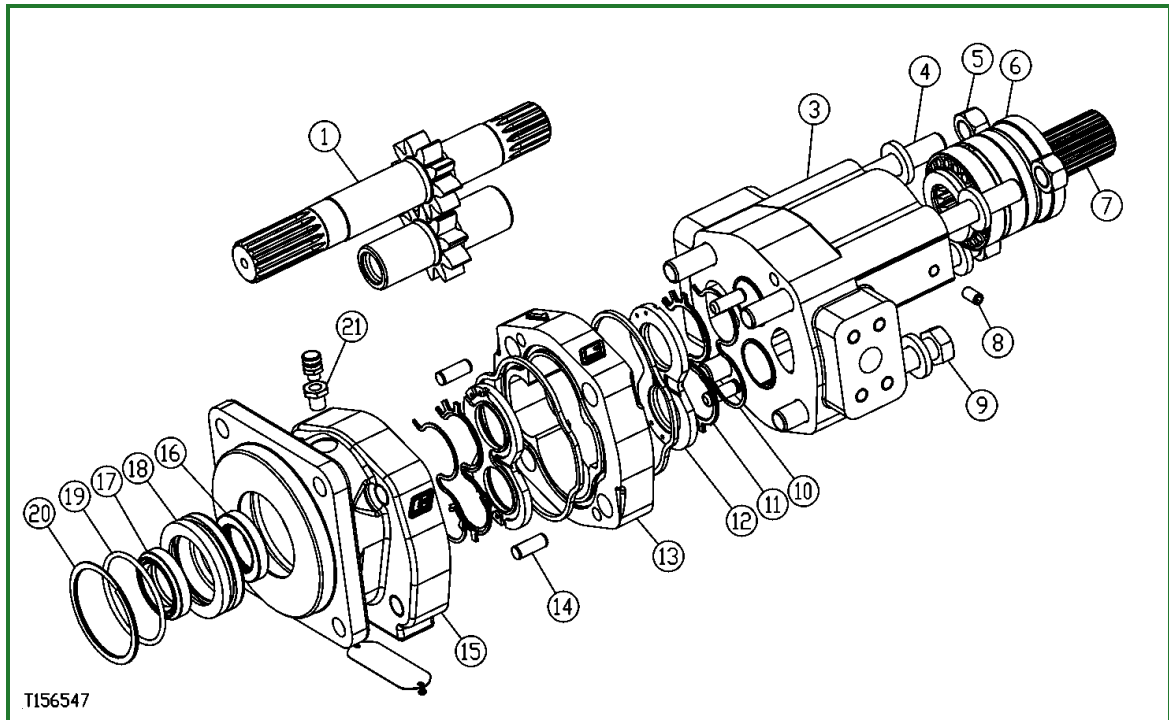
**T156547-UN: Hydraulic Pump with Winch****LEGEND:**

- 1 - Matched Gear Set
- 3 - Stub Shaft Housing
- 4 - Stud (3 used)
- 5 - Nut (6 used)
- 6 - Stub Shaft Retainer
- 7 - Stub Shaft Assembly
- 8 - Set Screw (2 used)
- 9 - Cap Screw
- 10 - Backing Seal (2 used)
- 11 - Channel Seal (2 used)
- 12 - Thrust Plate (2 used)
- 13 - Center Gear Housing
- 14 - Alignment Pin (4 used)
- 15 - Lower Gear Housing
- 16 - Seal
- 17 - Seal
- 18 - Seal Retainer
- 19 - O-Ring
- 20 - Retainer Ring

Apply clean hydraulic oil on all internal parts.

- 14. Install stub shaft assembly (7) in stub shaft housing (3), seating the bearing in the bottom of housing.
- 15. Install stub shaft retainer (6) in housing and tighten so there is no end play on stub shaft assembly (7).
- 16. Install and tighten set screws (8).
- 17. Install matched gear set (1) in center housing (13).

18. Install channel seals (11) in thrust plates (12). Install backing seals (10) into step of channel seals (11).
19. Install thrust plate and seal assemblies on the matched gear set with the seals facing away from the gear and sealing toward the pressure side of the pump as shown above.
20. Assemble center gear housing (13) and lower gear housing (15).
21. Assemble stub shaft housing (3) to center and lower gear housings.
22. Install studs with nuts and cap screws. Tighten cap screws to specifications.

Item	Measurement	Specification
Hydraulic Pump		
Hydraulic Pump Housing Studs and Cap Screws (With Winch Option)	Torque	271 N·m 200 lb-ft

Go to [Section_21:Group_2160](#)

TX,3260,SS2327-19-20061116

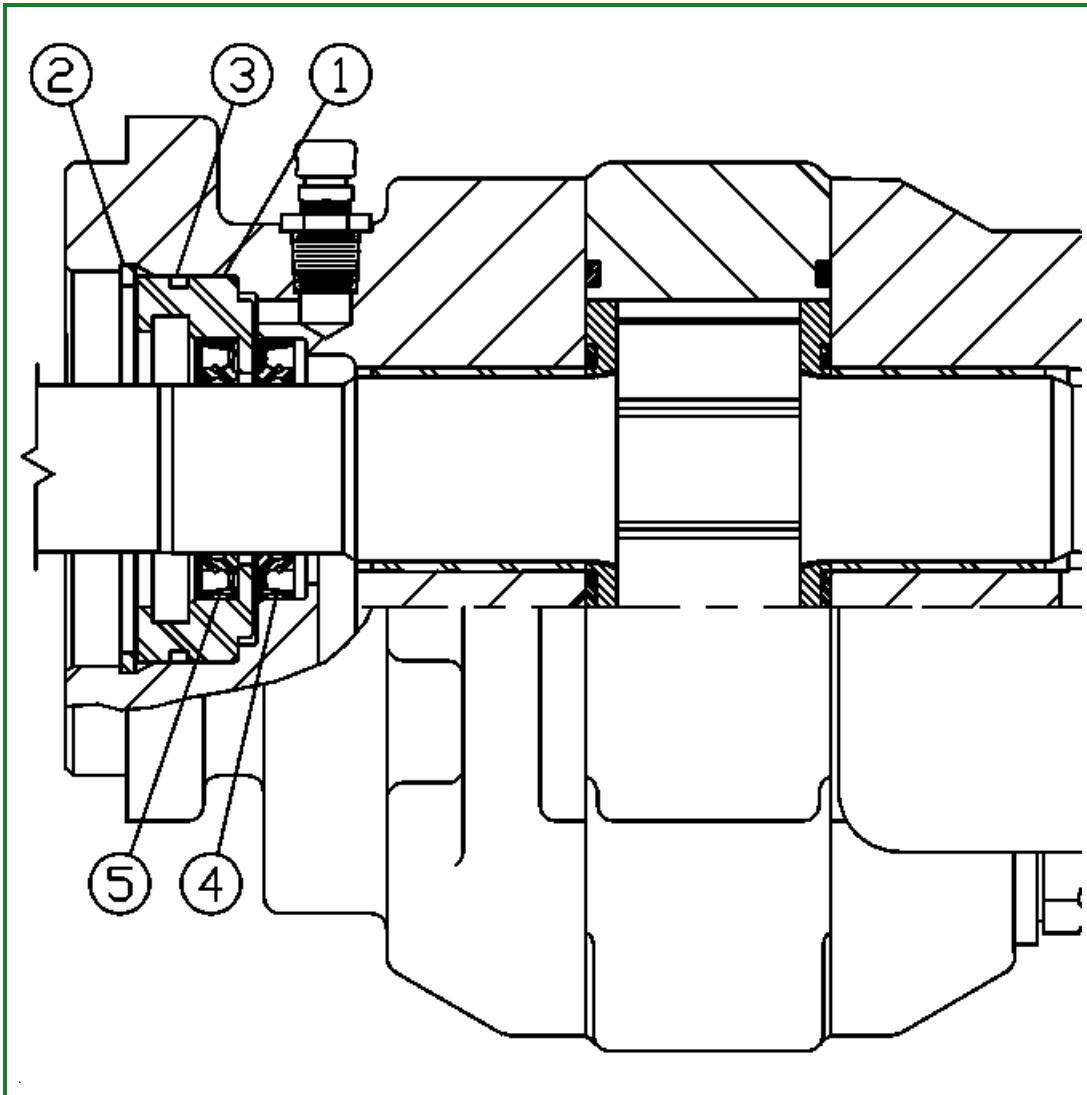
Hydraulic Pump (Without Winch Option) Disassemble and Assemble**T156546-UN: Pump Seal Assembly****LEGEND:**

- 1 - Seal Retainer
- 2 - Retaining Ring
- 3 - O-Ring
- 4 - Seal
- 5 - Seal

1. Remove retaining ring (2) and seal retainer (1).
2. Remove seals (4 and 5).
3. Install seal (4) flush with face of recess in housing with lip toward gear.
4. Install seal (5) flush with counterbore seal in retainer (1) with lip away from gear.
5. Install O-ring (3) on seal retainer and apply petroleum jelly to lip of seals and O-ring. Install seal retainer (1) and retaining ring (2).

6.

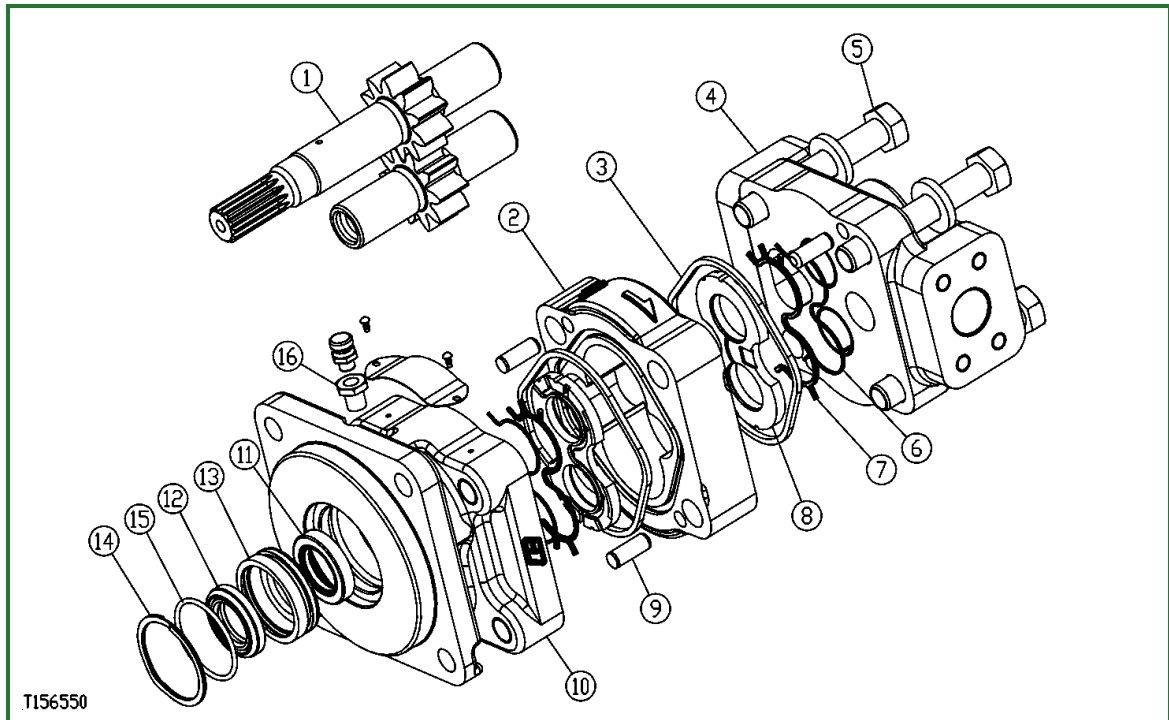
**T156550-UN: Hydraulic Pump Assembly****LEGEND:**

- 1 - Matched Gear Set
- 2 - Center Gear Housing
- 3 - Gasket Seal (2 used)
- 4 - Upper Gear Housing
- 5 - Cap Screw (4 used)
- 6 - Backing Seal (2 used)
- 7 - Channel Seal (2 used)
- 8 - Thrust Plate (2 used)
- 9 - Alignment Pin (4 used)
- 10 - Lower Gear Housing
- 11 - Seal
- 12 - Seal
- 13 - Seal Retainer
- 14 - O-ring
- 15 - Retainer Ring

Put a mark across housings (2, 4 and 10) to aid in assembly.

7. Remove cap screws and washers. Separate housings.
8. Remove matched gear set (1) and thrust plates (8) with seals (6 and 7).

9. **NOTE:**

Pump parts (1, 2, 4, 8 and 10) are not serviceable. If any of these parts are worn or damaged, replace pump.

Inspect parts for wear or damage. Replace parts as necessary.

10. Apply clean hydraulic oil on all internal parts.

11. Install matched gear set (1) in center gear housing (2).
12. Install channel seals (7) in thrust plates (8). Install backing seals (6) into step of channel seals.
13. Install thrust plate (8) and seal assemblies on the matched gear set (1) with the seals facing away from the gear and sealing toward the pressure side of the pump as shown above.
14. Assemble center gear housing (2) and lower gear housing (10).
15. Install upper gear housing and cap screws. Tighten cap screws to specifications.

Item	Measurement	Specification
Hydraulic Pump		
Hydraulic Pump Housing Cap Screws (Without Winch Option)	Torque	271 N·m 200 lb-ft

Go to [Section_21:Group_2160](#)

CED,OUTX782,567-19-20061116

Hydraulic Reservoir Remove and Install

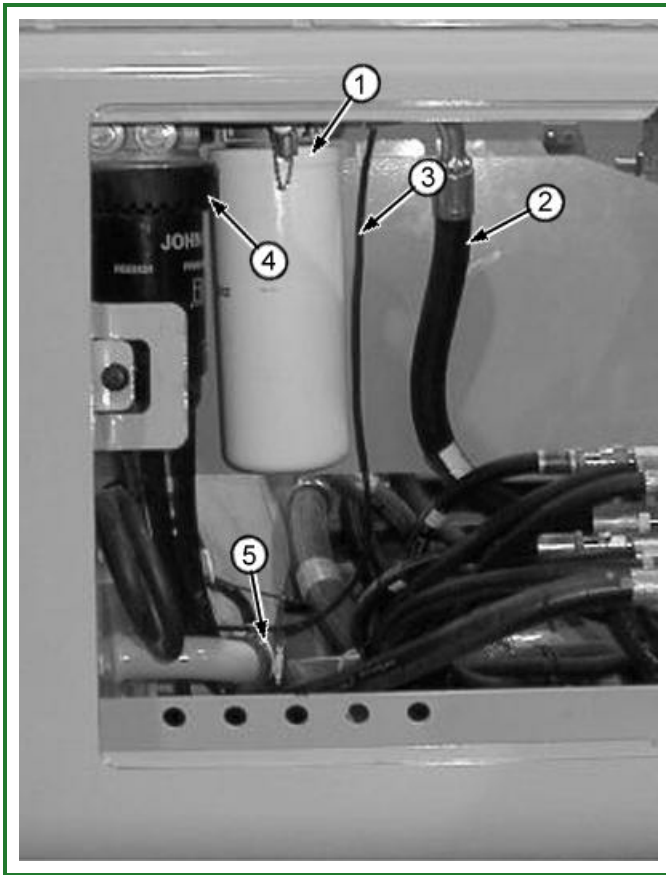

T117730B-UN: Hydraulic Filter and Fuel Filter

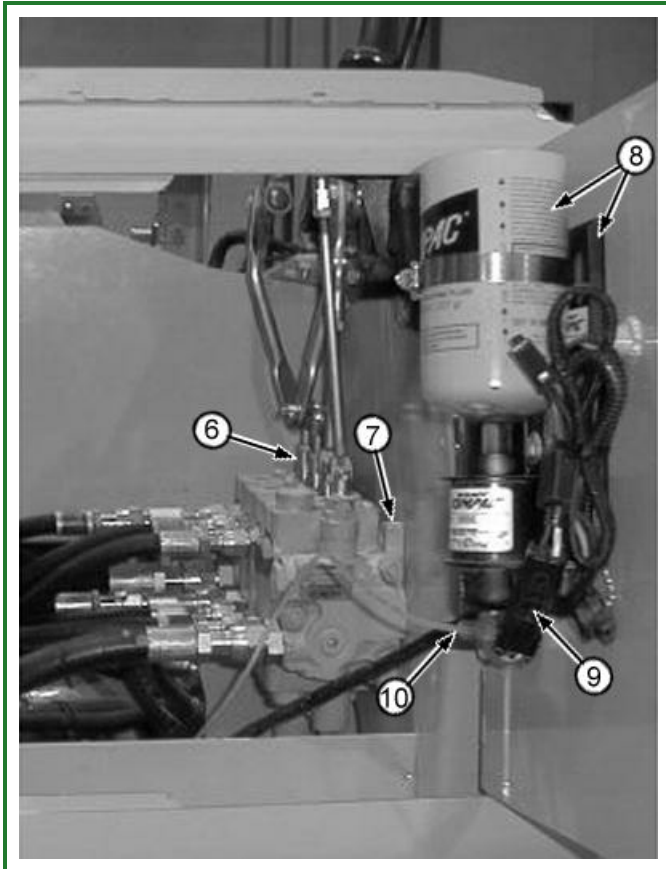

T117731B-UN: Starting Aid and Control Valve

LEGEND:

1 - Hydraulic Oil Filter

2 - Control Valve-to-Hydraulic Oil Filter Return Hose

- 3 - Hydraulic Oil Filter Restriction Indicator Lead
- 4 - Primary Fuel Filter
- 5 - Reservoir- to-Hydraulic Pump Suction Hose
- 6 - Control Valve Linkages
- 7 - Control Valve
- 8 - Bracket and Starting Aid Solenoid (if equipped)
- 9 - Starting Aid Wire Connector (if equipped)
- 10 - Starting Aid Tube (if equipped)

1. Remove ROPS or cab. [See Cab or ROPS Remove and Install](#) . (Group 1800.)
2. Drain reservoir.

Item	Measurement	Specification
Hydraulic Reservoir Capacity		32 L 8.5 gal

3. Disconnect control valve-to-hydraulic oil filter return hose (2), hydraulic oil filter restriction indicator lead (3), and reservoir-to-hydraulic pump suction hose (5).
4. Remove hydraulic oil filter (1) and primary fuel filter (4) with hoses attached and set aside.
5. Disconnect control valve linkages (6), starting aid wire connector (9), and starting aid tube (10).
6. Remove bracket and starting aid solenoid (8).
7. Remove control valve (7) with hoses attached and set aside.
8. Remove control levers, linkage, and bellcrank.

9.



T118032B-UN: Hydraulic Reservoir

Attach chain and hoist to reservoir.

10.

⚠ CAUTION:

Prevent possible crushing injury from removing hydraulic reservoir. Use proper lifting equipment and safety precautions.

Item	Measurement	Specification
Hydraulic Reservoir		
Hydraulic Reservoir Weight		102 kg 225 lb

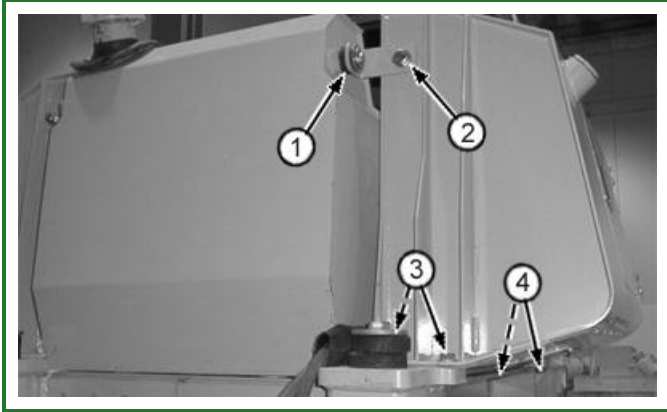

T118062B-UN: Hydraulic Reservoir

LEGEND:

- 1 - Cap Screw
- 2 - Cap Screw
- 3 - Cap Screw (2 used)
- 4 - Cap Screw (2 used)

Remove cap screws (1—4).

11. Install reservoir. Tighten cap screws (1—4) to specification.

Item	Measurement	Specification
Hydraulic Reservoir		
Hydraulic Reservoir-to-Main Frame Cap Screws	Torque	319 N·m 235 lb-ft
Fuel Tank Bracket-to-Hydraulic Reservoir Cap Screw	Torque	244 N·m 180 lb-ft
Bracket-to-Isolator-to-Fuel Tank Cap Screws	Torque	87 N·m 64 lb-ft

12.

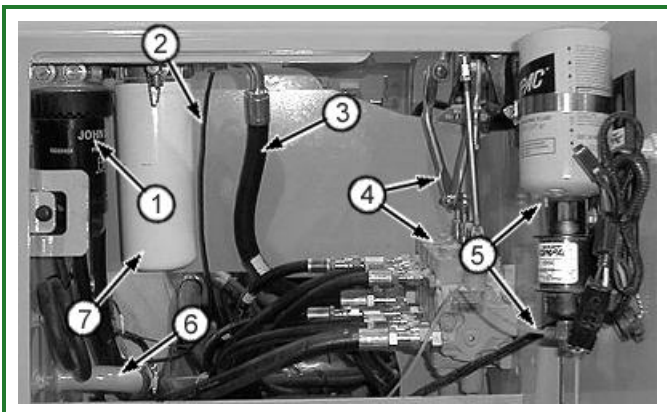

T118036B-UN: Hydraulic Reservoir

LEGEND:

- 1 - Water Separator
- 2 - Hydraulic Filter Restriction Indicator Lead
- 3 - Hydraulic Filter Hose
- 4 - Control Valve, Levers, Linkage and Bellcrank
- 5 - Bracket, Solenoid and Tube (if equipped)
- 6 - Reservoir Hose
- 7 - Hydraulic Filter

Install control valve, control valve levers and linkage and bellcrank (4).

- 13. Install bracket, solenoid, and tube (5), hydraulic filter (7) and water separator (1). Tighten cap screws to specification.

Item	Measurement	Specification
Hydraulic Reservoir		
Hydraulic Filter Nuts-to-Studs on Hydraulic Reservoir	Torque	31 N·m 23 lb-ft

- 14. Connect hydraulic filter restriction indicator lead (2), hydraulic filter hose (3), and reservoir hose (6).
- 15. Install cab or ROPS. [See Cab or ROPS Remove and Install](#) . (Group 1800.)
- 16. Fill hydraulic reservoir to specification.

Item	Measurement	Specification
Hydraulic Reservoir	Capacity	32 L 8.5 gal

Go to [Section_21:Group_2160](#)

CED,TX03768,2521-19-20060615

Hydraulic Reservoir and Hydrostatic Reservoir Cleanout Cover Remove and Install

1. Drain reservoir. See [Change Hydraulic Oil and Filter](#) or see [Change Transmission Oil and Filter](#) . (Operator's Manual.)
2. Remove components as necessary to access cleanout cover.

3. IMPORTANT:

Prevent fluid contamination. Remove paint and debris from sealing edge of cleanout cover prior to removal.

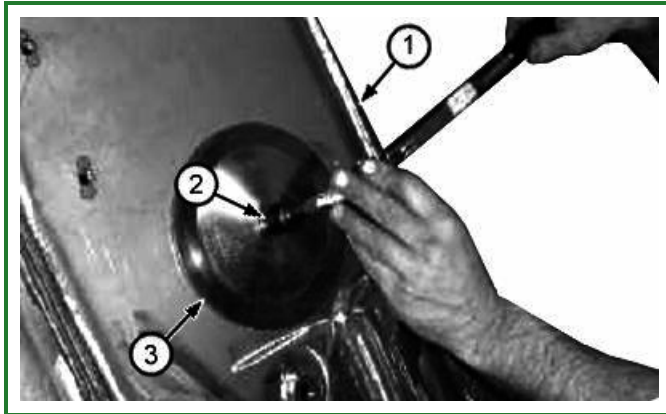

T197423A-UN: Hydraulic Reservoir Cleanout Cover

LEGEND:

- 1 - Hydraulic Reservoir
- 2 - Cap Screw
- 3 - Hydraulic Reservoir Cleanout Cover

Remove paint from sealing edge of hydraulic reservoir cleanout cover (3).

4. *NOTE:*

Do not fully remove cap screw (2) from inner plate.

Loosen cap screw (2) enough to remove cleanout cover assembly.

IMPORTANT:

Avoid fluid contamination. Paint may be chipped if cleanout cover drops into reservoir. Clean all debris from reservoir before installing cleanout cover.

5. Inspect gasket and cover plates for any cuts or loose material that could lead to contamination. Repair or replace parts as necessary.
6. IMPORTANT:

Avoid fluid contamination. Do not allow paint or debris to enter reservoir. Thoroughly clean if debris enters reservoir.

Inspect and remove paint buildup and debris from reservoir exterior wall.

Inspect locator tabs in reservoir to verify that they are perpendicular to reservoir wall.

7.

NOTE:

Cap screw should turn into weld nut without resistance. If resistance is felt, inspect weld nut for debris in threads and clean as necessary.

NOTE:

Avoid possible fluid leak. Verify O-ring is installed under head of cap screw before assembly.



T198245B-UN: Pre-Assembly

LEGEND:

4 - Inner Plate Tab

Loosely assemble cleanout cover with gasket and inner plate.

NOTE:

To ease installation, do not thread cap screw all the way into weld nut. Orient as shown.

8. **IMPORTANT:**

To prevent damage to the inner plate, the inner plate must seat flush against reservoir wall. Damage will result to locator tabs (5 and 6) if inner plate is installed incorrectly.

NOTE:

Install inner plate with inner plate tabs (4) facing toward top of reservoir. Inner plate must be located **between** upper (5) and lower (6) locator tabs.

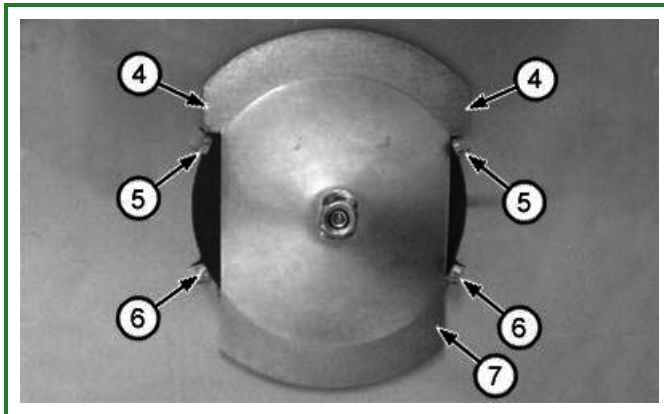

T198238B-UN: Tab Location View Inside Reservoir

LEGEND:

- 4 - Inner Plate Tab (2 used)
- 5 - Upper Locator Tab (2 used)
- 6 - Lower Locator Tab (2 used)
- 7 - Inner Plate

Install cleanout cover assembly starting with one corner of inner plate upper tabs.

Rest one tab of inner plate on upper locator tab (5) and rotate inner plate around until entirely inside reservoir. Pull back on cap screw to seat inner plate against reservoir wall **between** upper and lower locator tabs (5 and 6).

9.

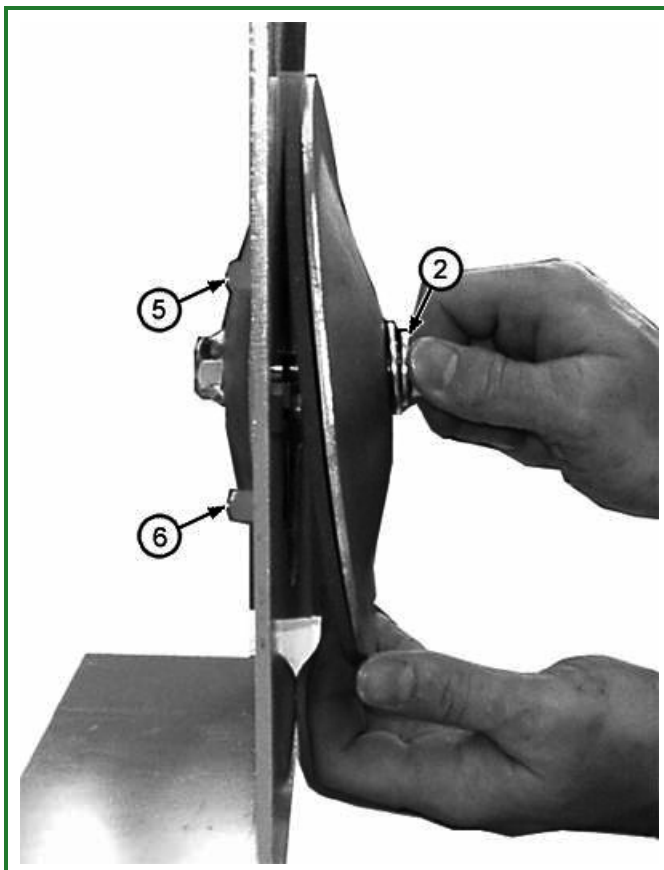

T198239B-UN: Cutaway View of Reservoir

LEGEND:

- 2 - Cap Screw
- 5 - Upper Locator Tab (2 used)
- 6 - Lower Locator Tab (2 used)

Hand tighten cap screw (2) while prying out on gasket and cleanout cover as shown to ensure that inner plate stays seated between upper and lower locator tabs (5 and 6).

10. **IMPORTANT:**

To prevent cleanout cover damage, do not use impact gun to tighten cap screw. Damage will result to cleanout cover assembly.

Tighten cap screw to specification.

Item	Measurement	Specification
Hydraulic Reservoir Cleanout Cover Cap Screw	Torque	47 N·m 35 lb.-ft.

- 11. Paint affected areas using TY6522 spray paint.
- 12. Install components removed to access cleanout cover.
- 13. Fill reservoir. [See Change Hydraulic Oil and Filter](#) or [see Change Transmission Oil and Filter](#) . (Operator's Manual.)

Go to [Section_21:Group_2160](#)

JW40272,00004E3-19-20090827

Hydraulic Reservoir Disassemble and Assemble

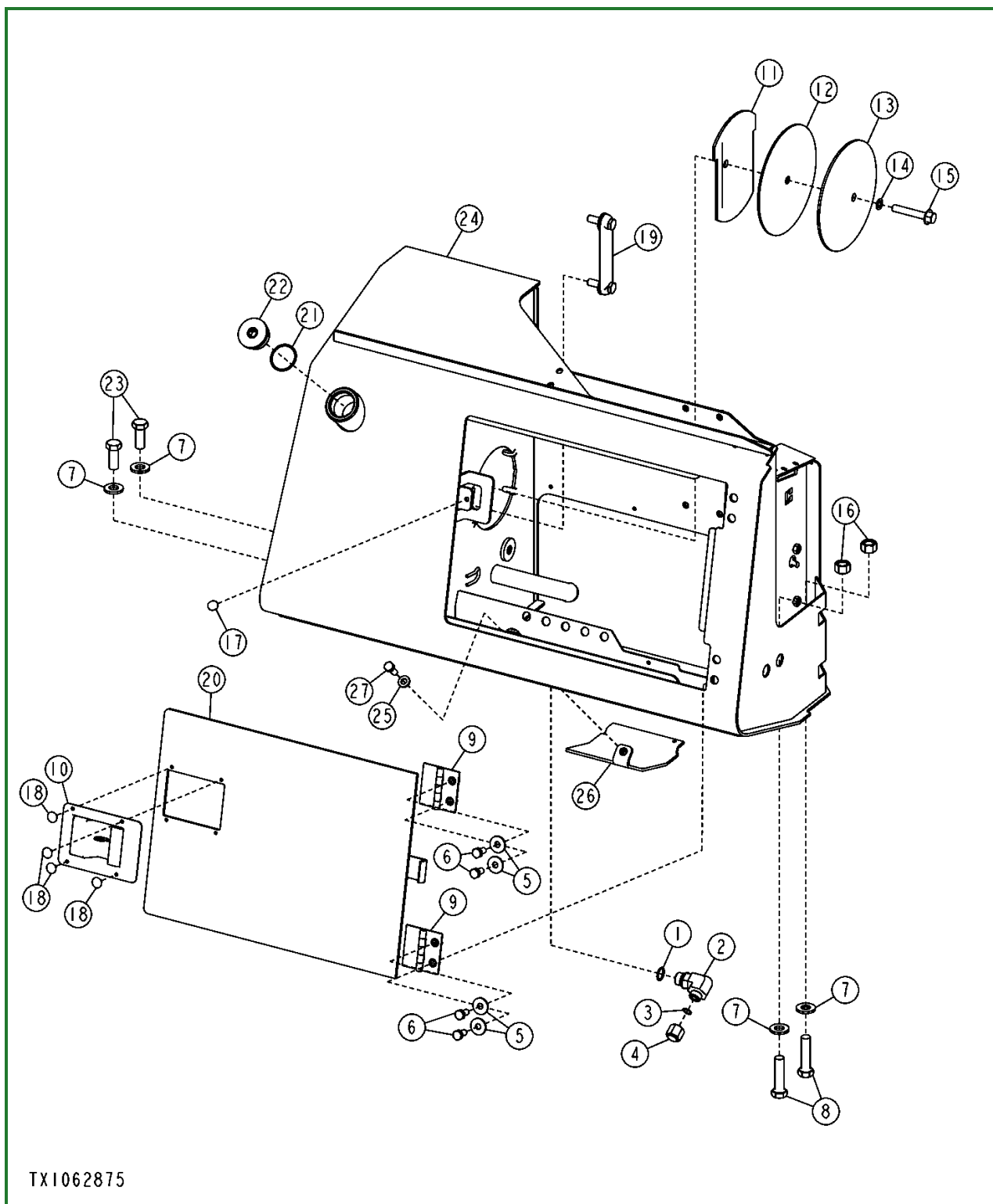

TX1062875

TX1062875-UN: Hydraulic Reservoir

LEGEND:

- 1 - O-Ring
- 2 - Elbow Fitting
- 3 - O-Ring
- 4 - Plug
- 5 - Washer (4 used)
- 6 - Cap Screw (4 used)
- 7 - Washer (4 used)
- 8 - Cap Screw (2 used)

- 9 - Hinge (2 used)
- 10 - Latch
- 11 - Inner Plate
- 12 - Gasket
- 13 - Cleanout Cover
- 14 - O-Ring
- 15 - Cap Screw
- 16 - Nut (2 used)
- 17 - Grommet
- 18 - Rivet (4 used)
- 19 - Level Gauge
- 20 - Door
- 21 - O-Ring
- 22 - Plug
- 23 - Cap Screw (2 used)
- 24 - Reservoir
- 25 - Washer
- 26 - Access Cover Plate
- 27 - Cap Screw

Item	Measurement	Specification
Hydraulic Reservoir		
Reservoir Cleanout Cover Cap Screw	Torque	47 N·m 35 lb.-ft.

Go to [Section_21:Group_2160](#)

CED, TX03768, 2522-19-20090820

Hydraulic Filter Remove and Install

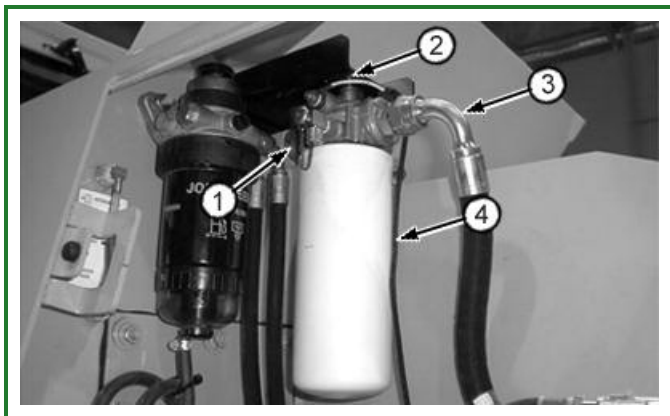

T118063B-UN: Hydraulic Filter

LEGEND:

- 1 - Hydraulic Filter-to-Hydraulic Reservoir Hose
- 2 - Cap Screw (4 used)
- 3 - Control Valve-to-Hydraulic Filter Hose
- 4 - Hydraulic Filter Wiring Lead

1. Open right side access door
2. Loosen oil fill plug on reservoir to release pressure
3. Disconnect hoses (1 and 3) and hydraulic filter wiring lead (4).
4. Remove cap screws (2) and remove hydraulic filter
5. Install hydraulic filter
6. Connect hoses (1 and 3) and hydraulic filter wiring lead (4).

Go to [Section_21:Group_2160](#)

KV70328,000007E-19-20060614

Hydraulic Filter Disassemble and Assemble

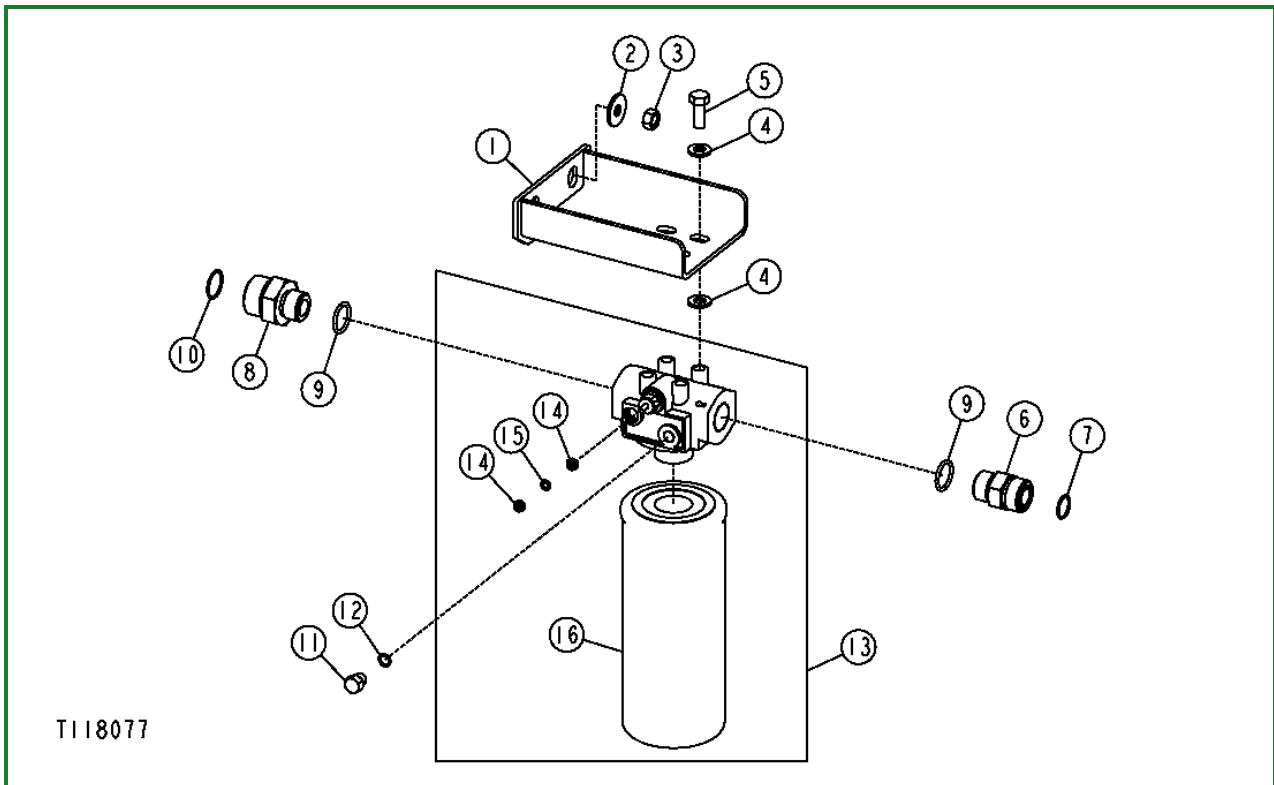
**T118077-UN: Hydraulic Filter****LEGEND:**

- 1 - Bracket
- 2 - Washer (2 used)
- 3 - Nut (2 used)
- 4 - Washer (8 used)
- 5 - Cap Screw (4 used)
- 6 - Adapter
- 7 - O-Ring
- 8 - Adapter
- 9 - O-Ring (2 used)
- 10 - O-Ring
- 11 - Plug
- 12 - O-Ring
- 13 - Filter Head
- 14 - Nut
- 15 - Washer
- 16 - Hydraulic Filter

1. Remove and replace parts as needed
2. Tighten nuts (3) and cap screws (5) to specification

Item	Measurement	Specification
Filter Mounting Bracket-to-Tank Stud Nuts	Torque	31 N·m 23 lb-ft
Bracket-to-Filter Base Cap Screws	Torque	50 N·m 37 lb-ft

Go to [Section_21:Group_2160](#)

KV70328,000007D-19-20060614

Section 32: Bulldozer

Group 3201: Blades

Blade Remove and Install

Blade Ball and Socket Alignment Procedure

Blade Retainer Split Bearing Installation

Cutting Edges and End Bits Remove and Install

Group 3215: Control Linkage

Hydraulic Control Lever Linkage Remove and Install

Auxiliary Hydraulic Control Lever Linkage Remove and Install

Group 3240: Frames

C-Frame Remove and Install

Group 3260: Hydraulic System

Hydraulic Control Valve Remove and Install

Hydraulic Control Valve Disassemble and Assemble

Wiper Seals and Lip Seals on Hydraulic Control Valve Remove and Install

Auxiliary Control Valve Section Disassemble and Assemble

Angle Control Valve Section Disassemble and Assemble

Tilt Control Valve Section Disassemble and Assemble

Lift Control Valve Section Disassemble and Assemble

Integrated Grade Control (IGC) Lever Remove and Install (S.N. 130886—)

Integrated Grade Control (IGC) Lever Disassemble and Assemble (S.N. 130886—)

System and Angle Circuit Relief Valve Disassemble and Assemble

Tilt Cylinder Remove and Install

Angle Cylinder Remove and Install

Lift Cylinder Remove and Install

Angle, Lift, and Tilt Cylinders Disassemble and Assemble (John Deere 120 Series Cylinders)

Blade Remove and Install

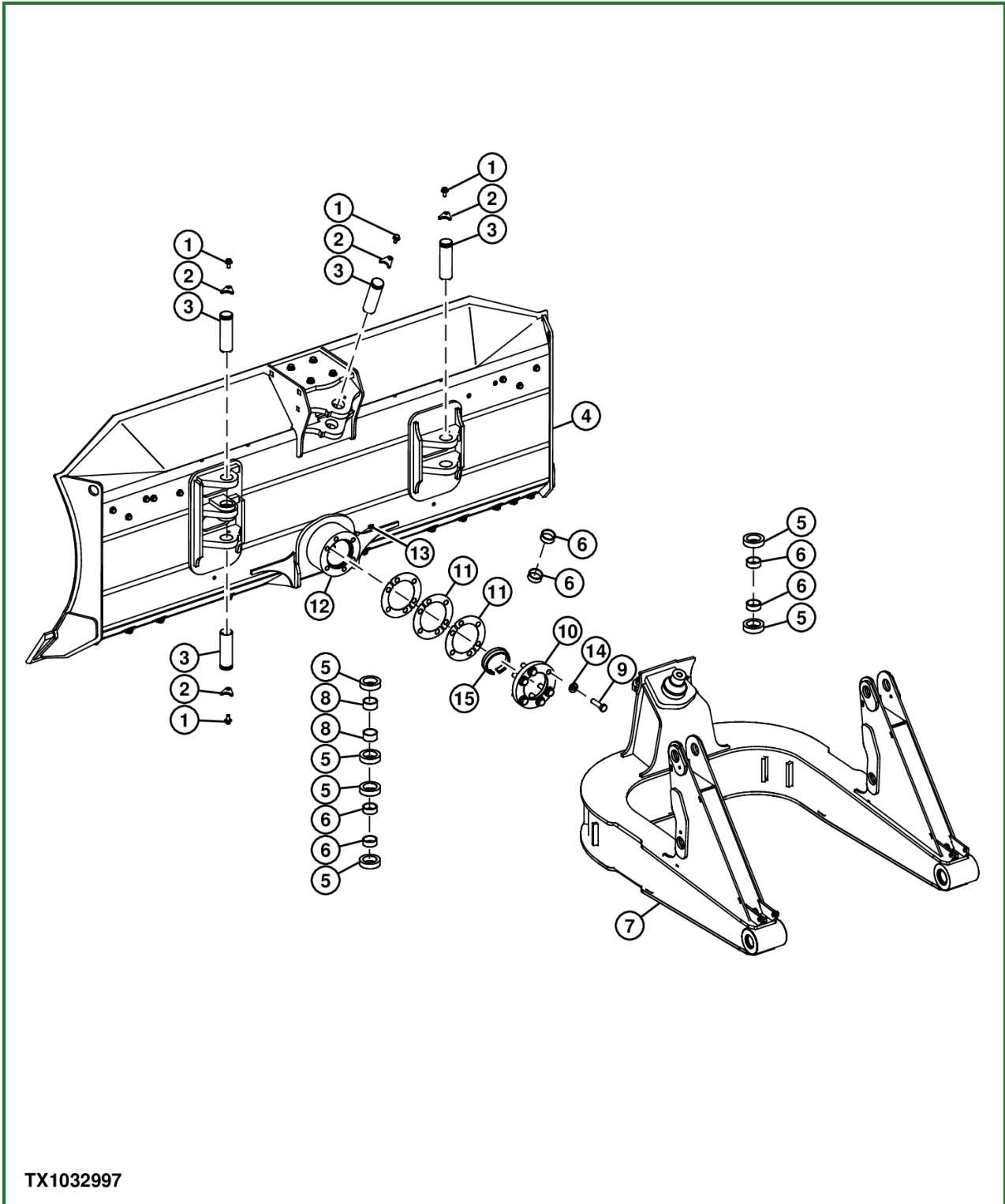

TX1032997-UN: C-Frame and Socket (3 shim)

LEGEND:

- 1 - Cap Screw (4 used)
- 2 - Retainer Plate (4 used)
- 3 - Pin (4 used)
- 4 - Blade
- 5 - Bushing (6 used)
- 6 - Bushing (6 used)
- 7 - C-Frame
- 8 - Bushing (2 used)

- 9 - Cap Screw (6 used)
- 10 - Socket Cap
- 11 - Shim (3 used)
- 12 - Socket
- 13 - Lubrication Fitting
- 14 - Washer (6 used)
- 15 - Split Bearing

There have been multiple shim configurations. If new shims are required the three shim design will retrofit previous configurations.

1. Park and prepare machine for service. See [Park And Prepare For Service Safely](#) . (Group 0001.)

2.

⚠ CAUTION:

To avoid injury from escaping fluid under pressure, stop engine and relieve the pressure in the system before disconnecting or connecting hydraulic or other lines. Tighten all connections before applying pressure.

Stop engine and operate control valves to relieve hydraulic system pressure.

3.

⚠ CAUTION:

Prevent possible crushing injury from heavy component. Use appropriate lifting device to support blade.

Install appropriate lifting device and apply stabilizing pressure to blade (4).

Item	Measurement	Specification
Blade Weight (approximate)		667 kg 1471 lb.

4. Remove both retainer plates (2) and cap screws (1) from tilt cylinder and angle cylinder pins on left side of blade.
5. Remove pin (3) from tilt cylinder head end and remove bushings (5 and 8).
6. Remove pin from angle cylinder rod end and remove bushings (5 and 6).
7. Remove retainer plate and cap screw from angle cylinder pin on right side of blade.
8. Remove pin from angle cylinder rod end and remove bushings.
9. Remove retainer plate and cap screw from pitch link pin at center of blade.
10. Remove pin from pitch link end and remove bushings.

11.

NOTE:

Socket cap remains on ball of C-frame until split bearing (15) is removed.

Remove cap screws (9), socket cap (10), and shims (11).

12.

⚠ CAUTION:

Prevent possible crushing injury from heavy component. Use appropriate lifting device when lifting component.

Using appropriate lifting device, remove blade.

Item	Measurement	Specification
Blade Weight (approximate)		667 kg 1471 lb.

13.

NOTE:

If split bearing needs replacement, see [Blade Retainer Split Bearing Installation](#) . (Group 3201.)

Inspect, repair, or replace parts as necessary.

14.

⚠ CAUTION:

Prevent possible crushing injury from heavy component. Use appropriate lifting device when lifting component.

Using an appropriate lifting device, install blade to machine. Leave lifting device attached to stabilize blade until all connections are made.

Item	Measurement	Specification
Blade Weight (approximate)		667 kg 1471 lb.

15. IMPORTANT:

Avoid machine damage. Do not lubricate zinc plated cap screws with oil or anti-seize lubricant. Always install cap screws dry.

Install bushings, pin, retainer plate (2), and cap screw (1) for pitch link. For machines with adjustable pitch linkage, see [Blade Pitch Linkage Adjustment](#) . (Group 9025-20.)

16. Install bushings, pin, retainer plate, and cap screw for angle cylinder rod end on right side of blade.

17. Install bushings, pin, retainer plate, and cap screw for angle cylinder rod end on lower left side of blade.

18. Install bushings (5 and 8), pin, retainer plate, and cap screw for tilt cylinder head end on upper left side of blade.

19. Check ball and socket adjustment:

1. Install ball socket retaining caps (if removed), washers, and cap screws without shims and tighten cap screws.

2. Measure gap between ball socket and retaining cap.
 3. Stack shims to equal gap between ball socket and retaining cap and add one additional shim.
20. Install shims, ball socket retaining caps (if removed), washers, and cap screws. Tighten cap screws only tight enough to hold socket cap and blade in place. Do not tighten to specification at this time.
 21. Remove lifting device.
 22. Angle blade to maximum pitch on each side. Tighten pivot cap screws to specification.

Item	Measurement	Specification
Pivot Cap Screws	Torque	255 N·m 188 lb-ft

23. Grease all points as specified in operator's manual. [See Grease Dozer Linkage and Blade Socket .](#) (Operator's Manual.)
24. Operate blade through full range of motion for all blade functions to check for binding.

Go to [Section_32:Group_3201](#)

KV70328,00002BE-19-20110524

Blade Remove and Install

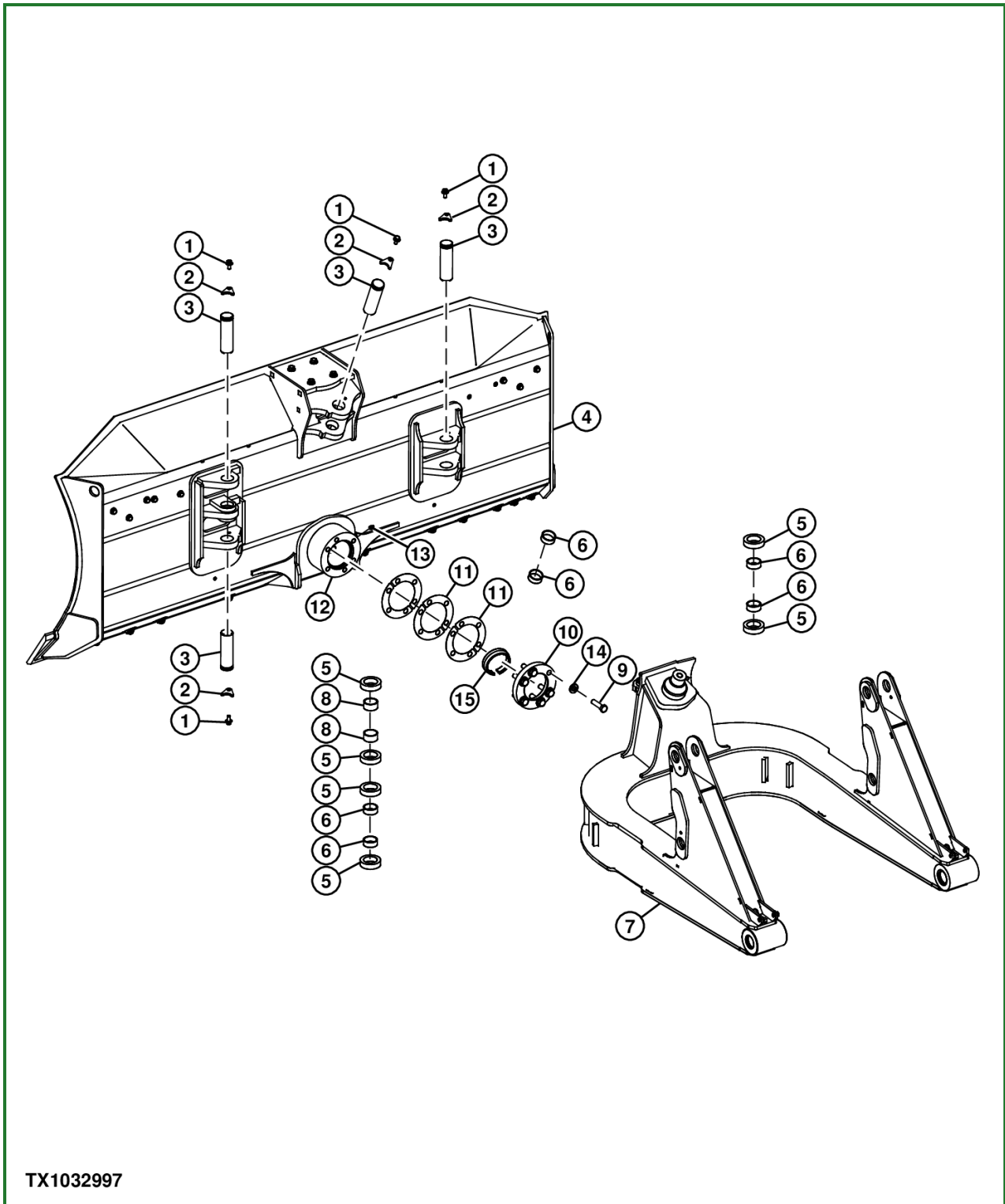

TX1032997-UN: C-Frame and Socket (3 shim)

LEGEND:

- 1 - Cap Screw (4 used)
- 2 - Retainer Plate (4 used)
- 3 - Pin (4 used)
- 4 - Blade
- 5 - Bushing (6 used)
- 6 - Bushing (6 used)
- 7 - C-Frame
- 8 - Bushing (2 used)

- 9 - Cap Screw (6 used)
- 10 - Socket Cap
- 11 - Shim (3 used)
- 12 - Socket
- 13 - Lubrication Fitting
- 14 - Washer (6 used)
- 15 - Split Bearing

There have been multiple shim configurations. If new shims are required the three shim design will retrofit previous configurations.

1. Park and prepare machine for service. See [Park And Prepare For Service Safely](#) . (Group 0001.)

2.

⚠ CAUTION:

To avoid injury from escaping fluid under pressure, stop engine and relieve the pressure in the system before disconnecting or connecting hydraulic or other lines. Tighten all connections before applying pressure.

Stop engine and operate control valves to relieve hydraulic system pressure.

3.

⚠ CAUTION:

Prevent possible crushing injury from heavy component. Use appropriate lifting device to support blade.

Install appropriate lifting device and apply stabilizing pressure to blade (4).

Item	Measurement	Specification
Blade Weight (approximate)		667 kg 1471 lb.

4. Remove both retainer plates (2) and cap screws (1) from tilt cylinder and angle cylinder pins on left side of blade.
5. Remove pin (3) from tilt cylinder head end and remove bushings (5 and 8).
6. Remove pin from angle cylinder rod end and remove bushings (5 and 6).
7. Remove retainer plate and cap screw from angle cylinder pin on right side of blade.
8. Remove pin from angle cylinder rod end and remove bushings.
9. Remove retainer plate and cap screw from pitch link pin at center of blade.
10. Remove pin from pitch link end and remove bushings.

11.

NOTE:

Socket cap remains on ball of C-frame until split bearing (15) is removed.

Remove cap screws (9), socket cap (10), and shims (11).

12.

⚠ CAUTION:

Prevent possible crushing injury from heavy component. Use appropriate lifting device when lifting component.

Using appropriate lifting device, remove blade.

Item	Measurement	Specification
Blade	Weight (approximate)	667 kg 1471 lb.

13.

NOTE:

If split bearing needs replacement, see [Blade Retainer Split Bearing Installation](#) . (Group 3201.)

Inspect, repair, or replace parts as necessary.

14.

⚠ CAUTION:

Prevent possible crushing injury from heavy component. Use appropriate lifting device when lifting component.

Using an appropriate lifting device, install blade to machine. Leave lifting device attached to stabilize blade until all connections are made.

Item	Measurement	Specification
Blade	Weight (approximate)	667 kg 1471 lb.

15. IMPORTANT:

Avoid machine damage. Do not lubricate zinc plated cap screws with oil or anti-seize lubricant. Always install cap screws dry.

Install bushings, pin, retainer plate (2), and cap screw (1) for pitch link. For machines with adjustable pitch linkage, see [Blade Pitch Linkage Adjustment](#) . (Group 9025-20.)

16. Install bushings, pin, retainer plate, and cap screw for angle cylinder rod end on right side of blade.

17. Install bushings, pin, retainer plate, and cap screw for angle cylinder rod end on lower left side of blade.

18. Install bushings (5 and 8), pin, retainer plate, and cap screw for tilt cylinder head end on upper left side of blade.

19. Check ball and socket adjustment:

1. Install ball socket retaining caps (if removed), washers, and cap screws without shims and tighten cap screws.

2. Measure gap between ball socket and retaining cap.
 3. Stack shims to equal gap between ball socket and retaining cap and add one additional shim.
20. Install shims, ball socket retaining caps (if removed), washers, and cap screws. Tighten cap screws only tight enough to hold socket cap and blade in place. Do not tighten to specification at this time.
 21. Remove lifting device.
 22. Angle blade to maximum pitch on each side. Tighten pivot cap screws to specification.

Item	Measurement	Specification
Pivot Cap Screws	Torque	255 N·m 188 lb-ft

23. Grease all points as specified in operator's manual. [See Grease Dozer Linkage and Blade Socket .](#) (Operator's Manual.)
24. Operate blade through full range of motion for all blade functions to check for binding.

Go to [Section_32:Group_3201](#)

KV70328,00002BE-19-20110524

Blade Ball and Socket Alignment Procedure

1. Park and prepare machine for service. See [Park and Prepare For Service Safely](#) . (Group 0001.)

2.

NOTE:

Blade is not removed for adjustment procedure; graphic shows exploded view for part reference only.

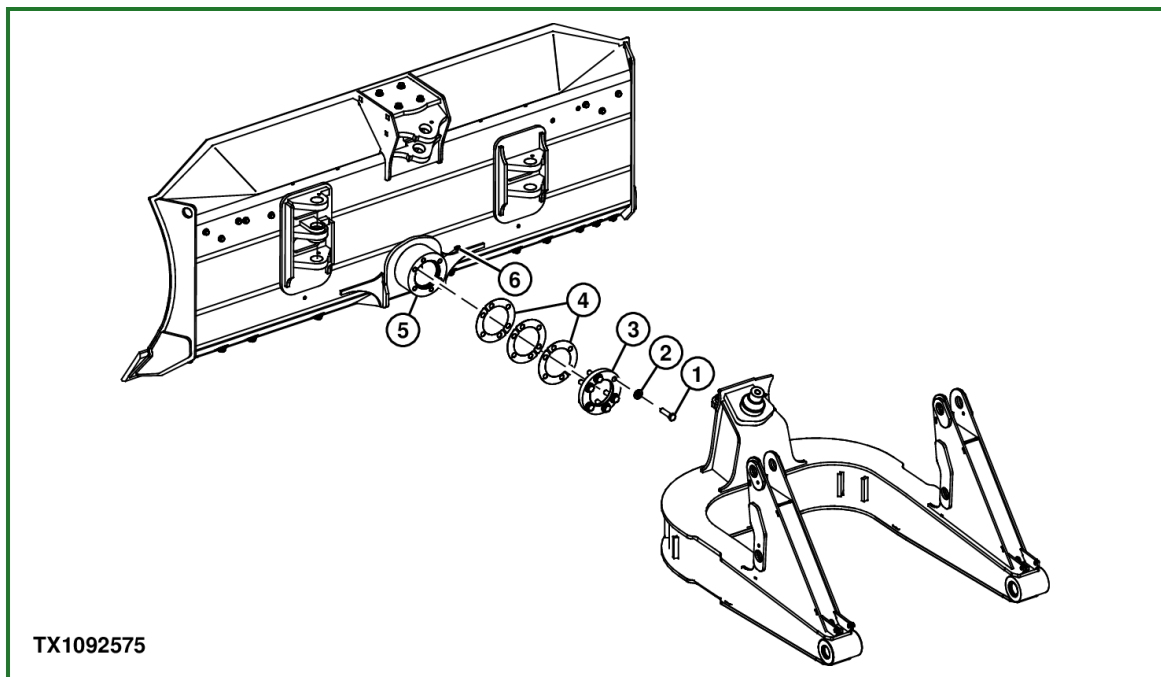

TX1092575-UN: Shim Removal

LEGEND:

- 1 - Cap Screw (6 used)
- 2 - Washer (6 used)
- 3 - Ball Socket Retaining Cap
- 4 - Shim (as needed)
- 5 - Ball Socket
- 6 - Grease Fitting

Remove cap screws (1), washers (2), and ball socket retaining cap (3).

3. Remove all shims (4).
4. Install ball socket retaining cap, washers, and cap screws without shims and tighten cap screws.
5. Measure gap between ball socket and retainer cap.
6. IMPORTANT:

Avoid machine damage. Do not lubricate zinc plated cap screws with oil or anti-seize lubricant. Always install dry.

Install shims to fill gap and add one additional shim. Install ball socket retaining cap screws.

7. Tighten cap screws to hold ball socket retaining cap and blade in place; do not tighten to specification at

this time.

8.

NOTE:

Operating blade to maximum pitch both right and left will center the ball in the socket before tightening socket retaining cap screws to specification.

Start machine. Operate blade to maximum pitch both right and left to center the ball in its socket.

9. Stop machine and tighten ball socket retaining cap screws to specification.

Item	Measurement	Specification
Ball Socket Retaining Cap Screw	Torque	255 N·m 188 lb-ft

10. IMPORTANT:

Grease socket and ball joint every 10 hours or daily. Only use grease specified on machine's periodic maintenance chart. Add grease until it escapes at joint.

Grease all points as specified in Operator's Manual. [See Grease Dozer Linkage and Blade Socket](#) . (Operator's Manual.)

11. Operate blade through full range of motion for all blade functions to check for binding.

Go to [Section_32:Group_3201](#)

MH66088,0000E05-19-20120921

Blade Retainer Split Bearing Installation

-: Essential Tools

ESSENTIAL TOOLS

AT342478 Blade Retain Ring Install Kit

Use this procedure to install or replace the blade retainer split bearing.

Order AT342478 Blade Retain Ring Install Kit if doing this procedure for the first time.

1.

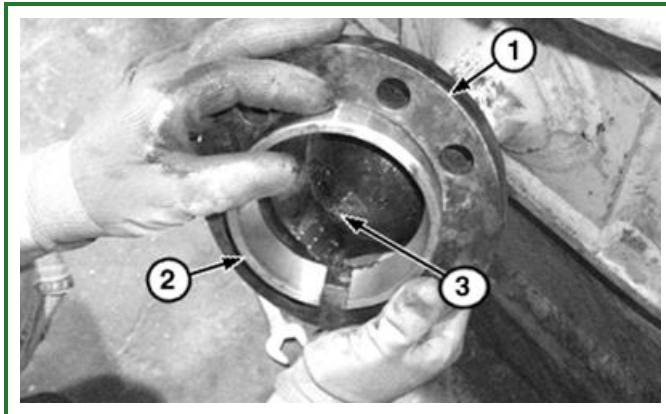

TX1027253A-UN: Blade Retainer Split Bearing

LEGEND:

- 1 - Blade Pivot Retainer
- 2 - Blade Retainer Split Bearing
- 3 - Blade Pivot Ball

Install blade pivot retainer (1) on blade pivot ball (3) on C-frame.

2.

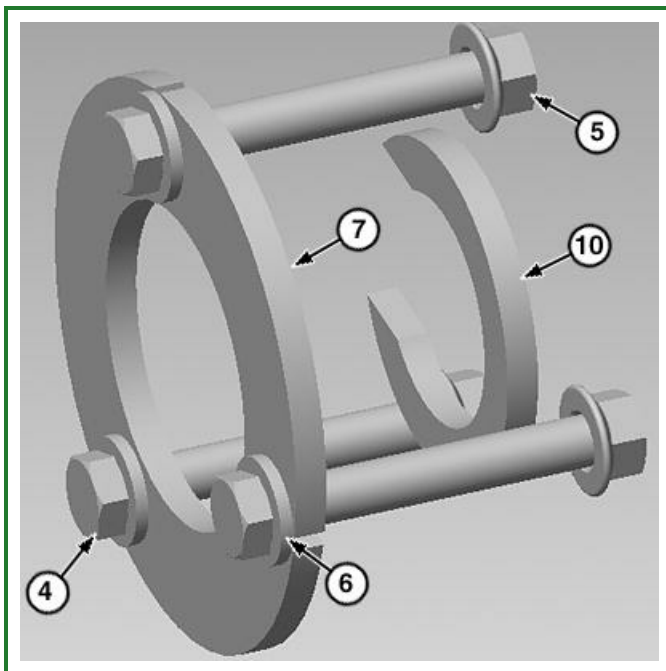

TX1029865A-UN: Installation Tool

LEGEND:

- 4 - Cap Screw (3 used)

5 - Nut (3 used)

6 - Washer (3 used)

7 - T231226 Outer Installation Plate

10 - T231227 Inner Installation Plate

Install inner installation plate (10) between blade pivot retainer and blade pivot ball.

3. Install blade retainer split bearing (2) onto blade pivot ball.
4. Using cap screws (4), washers (6), and nuts (5), install outer installation plate (7).
5. Tighten cap screws evenly until split bearing snaps over pivot ball.
6. Remove nuts, washers, cap screws, outer installation plate, and inner installation plate.

Go to [Section_32:Group_3201](#)

FB87413,5F5E30B-19-20120831

Cutting Edges and End Bits Remove and Install

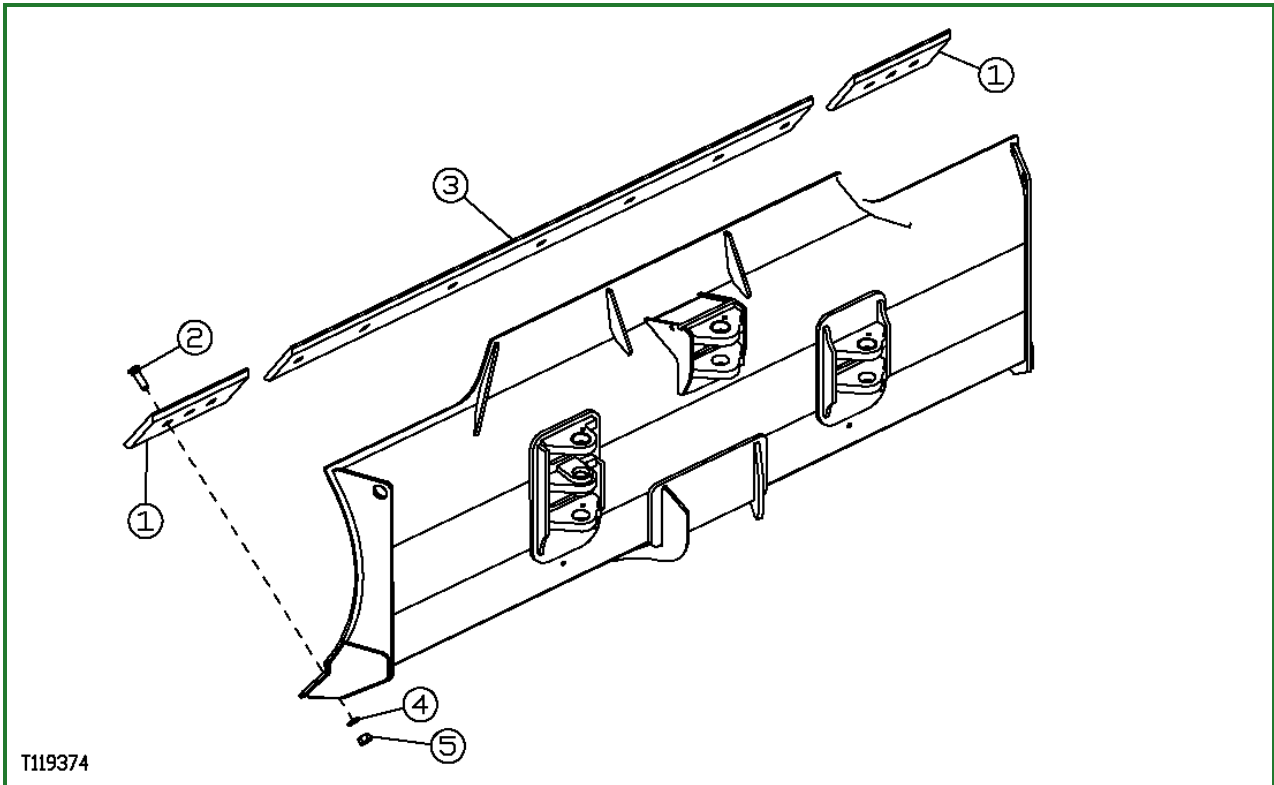

T119374-UN: Cutting Edge and End Bits 97 in. Blade Shown

LEGEND:

- 1 - End Bit (2 used)
- 2 - Cap Screw (13 used)
- 3 - Cutting Edge
- 4 - Washer (13 used)
- 5 - Nut (13 used)

1. Block frame with cutting edge above ground level.
2. Remove parts (1—5).
3. Inspect parts and replace as necessary.
4. Install parts (1—5). Tighten hardware.

Go to [Section_32:Group_3201](#)

CED, TX03768, 2525-19-20071210

Hydraulic Control Lever Linkage Remove and Install

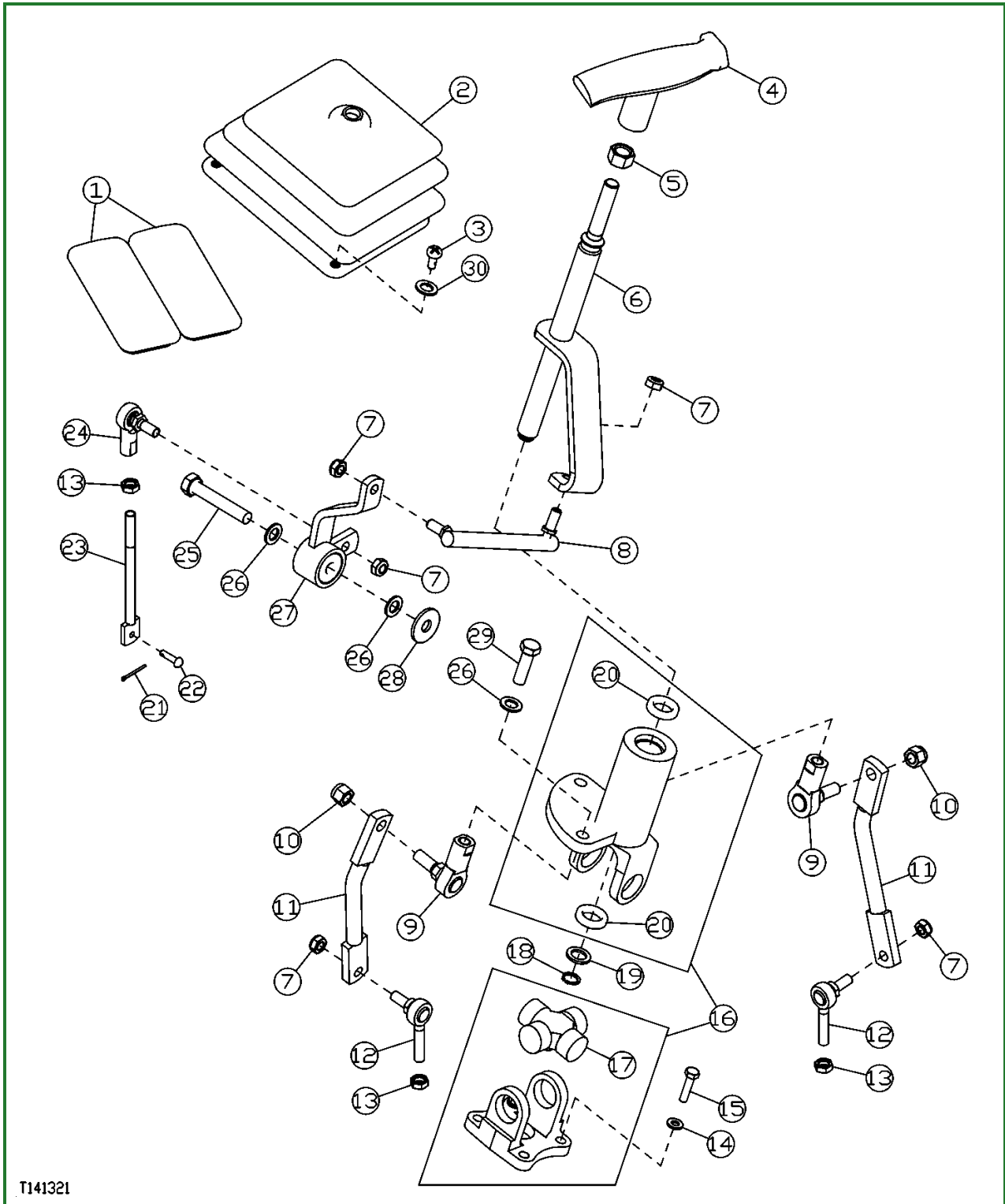

T141321

T141321-UN: Hydraulic Control Linkage

LEGEND:

- 1 - Grommet (2 used)
- 2 - Boot
- 3 - Cap Screw (4 used)
- 4 - T-Bar Control Handle
- 5 - Nut
- 6 - Control Shaft
- 7 - Lock Nut (5 used)
- 8 - Stud Link Ball Joint

- 9 - Ball Joint (2 used)
- 10 - Lock Nut (2 used)
- 11 - Tilt Valve and Lift Section Link (2 used)
- 12 - Ball Joint (2 used)
- 13 - Nut (3 used)
- 14 - Washer (4 used)
- 15 - Cap Screw (4 used)
- 16 - U-Joint Control Housing
- 17 - U-Joint
- 18 - Snap Ring
- 19 - Washer
- 20 - Bearing (2 used)
- 21 - Cotter Pin
- 22 - Pin
- 23 - Rod-to-Angle Valve Section Link
- 24 - Ball Joint
- 25 - Cap Screw
- 26 - Washer (4 used)
- 27 - Bellcrank
- 28 - Washer
- 29 - Cap Screw (2 used)
- 30 - Washer (4 used)

1. Open access door to control valve.
2. Remove lock nuts (7) on tilt and lift valve ball joints (12).
3. Remove cotter pin (21) and pin (22) on angle valve rod.
4. Remove cap screw (25) and washer (26) from bellcrank (27).
5. Remove cap screws (15) and washers (14) from U-joint assembly.
6. Remove cap screws (3) and boot (2). Remove assembly.
7. Disassemble and assemble parts as required.
8. Tighten cap screws (15).

Item	Measurement	Specification
T-Bar Control Valve Linkage		
Mount T-Bar Linkage-to-Hydraulic Tank Cap Screws	Torque	15 N·m 11 lb-ft

9. Tighten lock nuts (10) to specification.

Item	Measurement	Specification
T-Bar Control Valve Linkage		
3/8 Lock Nut Torque		35 N·m 26 lb-ft

10. Tighten lock nuts (7) to specification.

Item	Measurement	Specification
T-Bar Control Valve Linkage		
5/16 Lock Nut Torque		19 N·m 14 lb-ft

11. Adjust T-bar linkage. [See Hydraulic Control Lever Linkage Adjustment](#) . (Group 9025-20.)

Go to [Section_32:Group_3215](#)

CED, TX03768, 2526-19-20010412

Hydraulic Control Lever Linkage Remove and Install

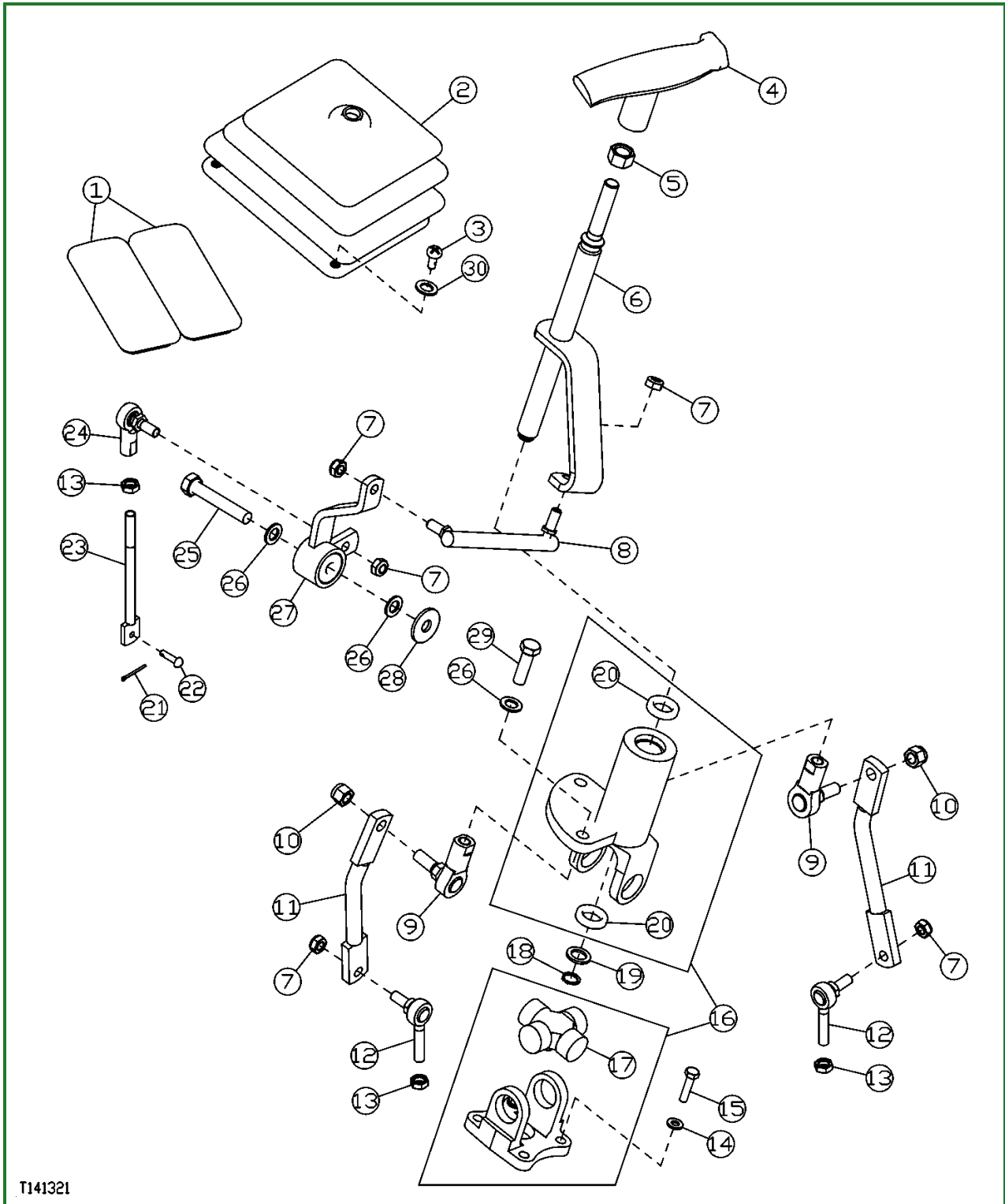

T141321

T141321-UN: Hydraulic Control Linkage

LEGEND:

- 1 - Grommet (2 used)
- 2 - Boot
- 3 - Cap Screw (4 used)
- 4 - T-Bar Control Handle
- 5 - Nut
- 6 - Control Shaft
- 7 - Lock Nut (5 used)
- 8 - Stud Link Ball Joint

- 9 - Ball Joint (2 used)
- 10 - Lock Nut (2 used)
- 11 - Tilt Valve and Lift Section Link (2 used)
- 12 - Ball Joint (2 used)
- 13 - Nut (3 used)
- 14 - Washer (4 used)
- 15 - Cap Screw (4 used)
- 16 - U-Joint Control Housing
- 17 - U-Joint
- 18 - Snap Ring
- 19 - Washer
- 20 - Bearing (2 used)
- 21 - Cotter Pin
- 22 - Pin
- 23 - Rod-to-Angle Valve Section Link
- 24 - Ball Joint
- 25 - Cap Screw
- 26 - Washer (4 used)
- 27 - Bellcrank
- 28 - Washer
- 29 - Cap Screw (2 used)
- 30 - Washer (4 used)

1. Open access door to control valve.
2. Remove lock nuts (7) on tilt and lift valve ball joints (12).
3. Remove cotter pin (21) and pin (22) on angle valve rod.
4. Remove cap screw (25) and washer (26) from bellcrank (27).
5. Remove cap screws (15) and washers (14) from U-joint assembly.
6. Remove cap screws (3) and boot (2). Remove assembly.
7. Disassemble and assemble parts as required.
8. Tighten cap screws (15).

Item	Measurement	Specification
T-Bar Control Valve Linkage		
Mount T-Bar Linkage-to-Hydraulic Tank Cap Screws	Torque	15 N·m 11 lb-ft

9. Tighten lock nuts (10) to specification.

Item	Measurement	Specification
T-Bar Control Valve Linkage		
3/8 Lock Nut Torque		35 N·m 26 lb-ft

10. Tighten lock nuts (7) to specification.

Item	Measurement	Specification
T-Bar Control Valve Linkage		
5/16 Lock Nut Torque		19 N·m 14 lb-ft

11. Adjust T-bar linkage. [See Hydraulic Control Lever Linkage Adjustment](#) . (Group 9025-20.)

Go to [Section_32:Group_3215](#)

CED, TX03768,2526-19-20010412

Auxiliary Hydraulic Control Lever Linkage Remove and Install

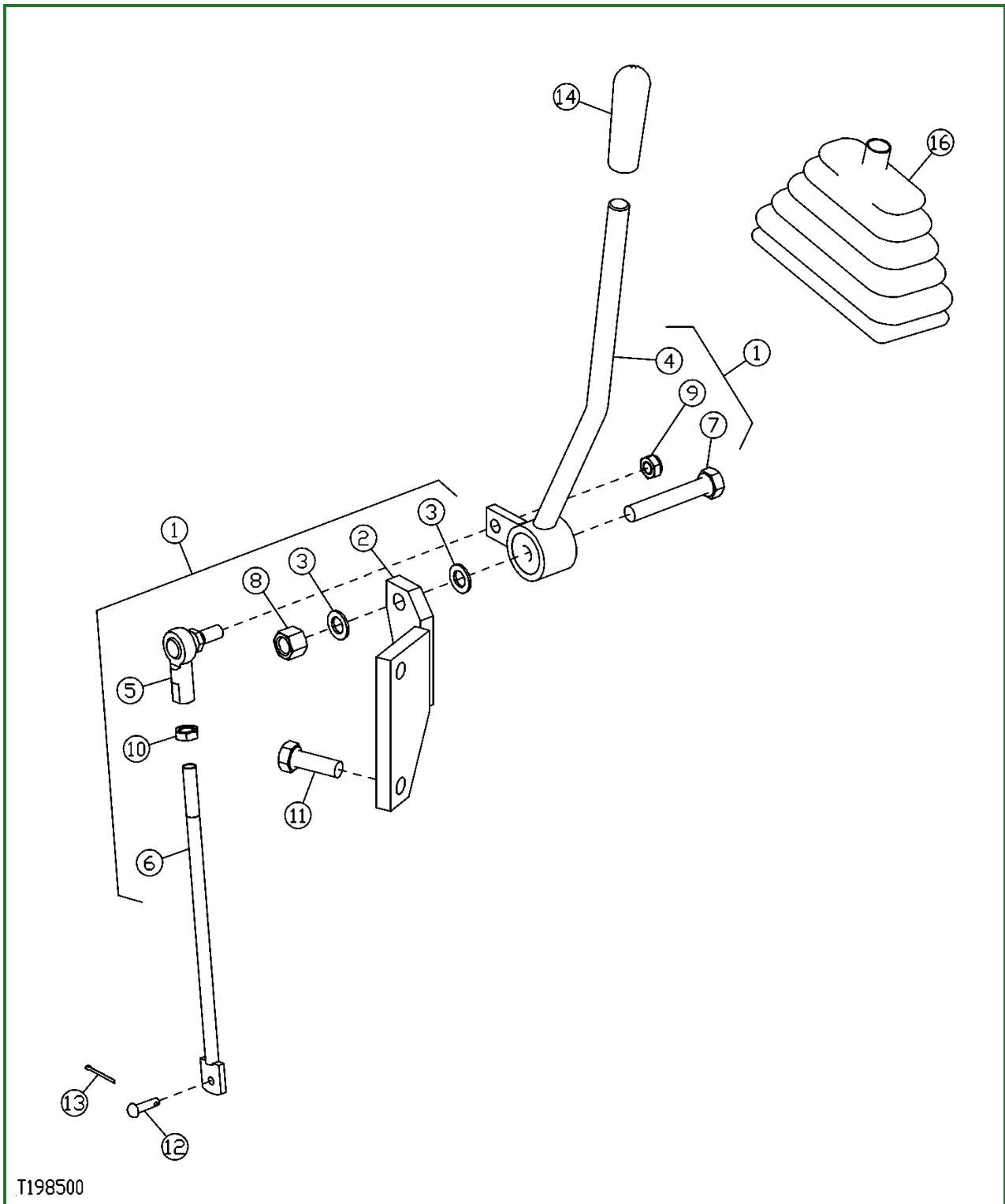

T198500-UN: Aux Valve

LEGEND:

- 1 - Control Valve Linkage Assembly
- 2 - Bracket
- 3 - Washer
- 4 - Lever
- 5 - Ball Joint
- 6 - Rod-to-Auxiliary Valve
- 7 - Cap Screw
- 8 - Lock Nut

- 9 - Lock Nut
- 10 - Nut
- 11 - Cap Screw (2 used)
- 12 - Pin
- 13 - Cotter Pin
- 14 - Grip
- 15 - Grommet (Not Shown)
- 16 - Boot

1. Open access cover to control valve.
2. Remove pin (12).
3. Remove cap screw (7).
4. Remove boot (16).
5. Remove auxiliary linkage assembly.
6. Disassemble and assemble parts as required.
7. Install cap screw (7), pin (12), and boot (16). Tighten cap screw (7) to specification.

Item	Measurement	Specification
Auxiliary Linkage		
Lever-to-Bracket Cap Screw	Torque	50 N·m 37 lb-ft

8. Adjust auxiliary control linkage. [See Auxiliary Lever Linkage Adjustment](#) . (Group 9025-20.)

Go to [Section_32:Group_3215](#)

CED,OUTX547,195-19-19990409

C-Frame Remove and Install

1. **NOTE:**
C-Frame can be removed with blade attached.

Lower all equipment to the ground.

2. Stop engine. Operate all controllers to relieve hydraulic system pressure.
3. Remove blade if necessary. [See Blade Remove and Install](#) . (Group 3201.)

4. **NOTE:**
If equipped with heavy duty grille, remove upper hose guard.

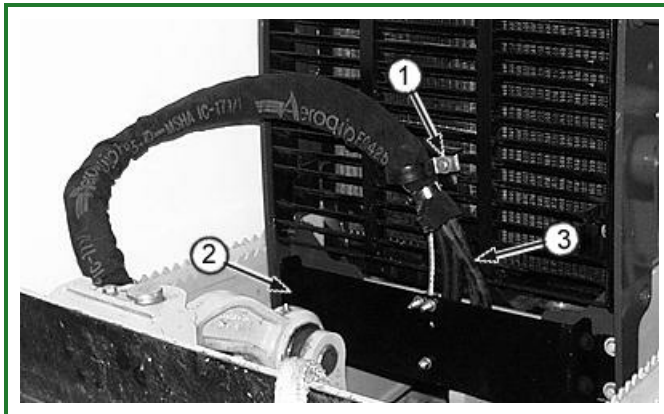

T119392B-UN: Cylinder hoses

LEGEND:

- 1 - Hose Clamp
- 2 - Hose Guard
- 3 - Cylinder Hose (4 used)

Remove clamp (1).

5. Remove hose guard (2).

6. **⚠ CAUTION:**



X9811-UN: Fluid Caution

Escaping fluid under pressure can penetrate the skin causing serious injury. Avoid the hazard by relieving pressure before disconnecting hydraulic or other lines. Tighten all connections before applying pressure. Search for leaks with a piece of cardboard. Protect hands and body from high pressure fluids.

If an accident occurs, see a doctor immediately. Any fluid injected into the skin must be surgically removed within a few hours or gangrene may result. Doctors unfamiliar with this type of injury should reference a knowledgeable medical source. Such information is available from Deere & Company Medical Department in Moline, Illinois, U.S.A.

Disconnect four hoses (3). Cap and plug all openings.

7.

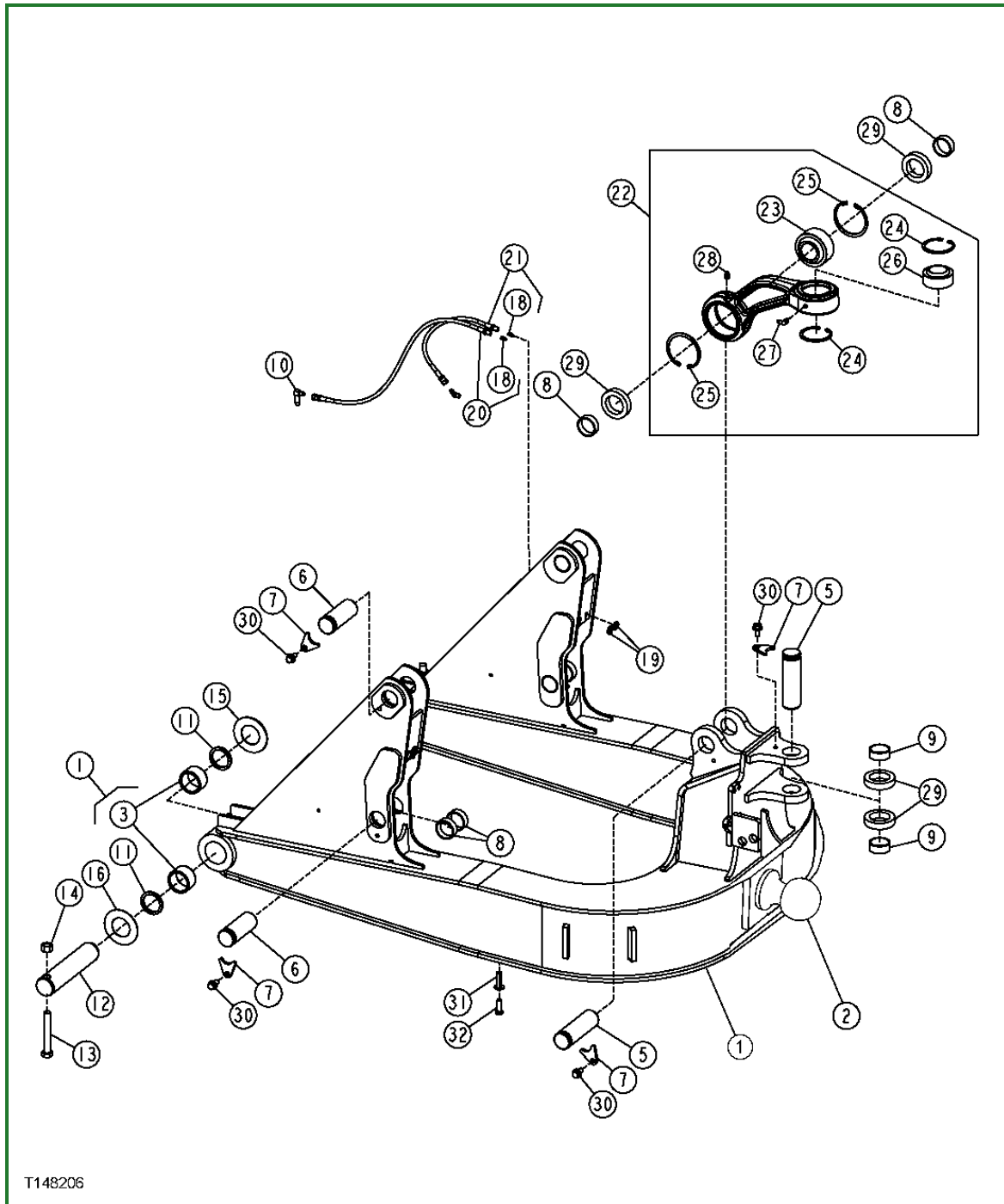

T148206

T148206-UN: Converted C-Frame**LEGEND:**

- 1 - C-Frame
- 2 - Pivot Ball
- 3 - Bushing (4 used)
- 4 - Not Used
- 5 - Pin (2 used)
- 6 - Lift Cylinder Pin (4 used)
- 7 - Pin Retainer (6 used)
- 8 - Bushing (6 used)
- 9 - Bushing (2 used)
- 10 - Elbow Fitting (2 used)
- 11 - Seal (4 used)
- 12 - Pin (2 used)
- 13 - Cap Screw (2 used)

- 14 - Lock Nut (2 used)
- 15 - Washer (2 used)
- 16 - Washer (2 used)
- 17 - Not Used
- 18 - Lubrication Fitting (4 used)
- 19 - Nut (4 used)
- 20 - Lubrication Hose
- 21 - Lubrication Hose
- 22 - Strut Support
- 23 - Bushing
- 24 - Snap Ring (2 used)
- 25 - Snap Ring (2 used)
- 26 - Bushing
- 27 - Lubrication Fitting
- 28 - Lubrication Fitting
- 29 - Bushing (4 used)
- 30 - Cap Screw (6 used)
- 31 - Nut (3 used)
- 32 - Cap Screw (3 used)

Remove lift cylinder pins (6) from rod end of lift cylinders.

8.

⚠ CAUTION:

Prevent possible crushing injury from removing blade. Use proper lifting equipment and safety precautions.

Item	Measurement	Specification
C-Frame		
C-Frame with Blade	Weight	1040 kg 2294 lb
C-Frame	Weight	375 kg 826 lb

Place chains around C-frame or C-frame and blade. Attach a hoist.

- 9. Remove pins (12) and remove C-frame or C-frame and blade.
- 10. Inspect all parts and replace if necessary.
- 11. Install C-frame, C-frame pins, and lifting cylinder rod end pins.
- 12. If cylinder hoses were removed, [see Hydraulic Component Location](#) . (Group 9025-15.)

Go to [Section_32:Group_3240](#)

BT40170,000001C-19-20020617

C-Frame Remove and Install

1.

NOTE:

C-Frame can be removed with blade attached.

Lower all equipment to the ground.

2. Stop engine. Operate all controllers to relieve hydraulic system pressure.
3. Remove blade if necessary. [See Blade Remove and Install](#) . (Group 3201.)

4.

NOTE:

If equipped with heavy duty grille, remove upper hose guard.

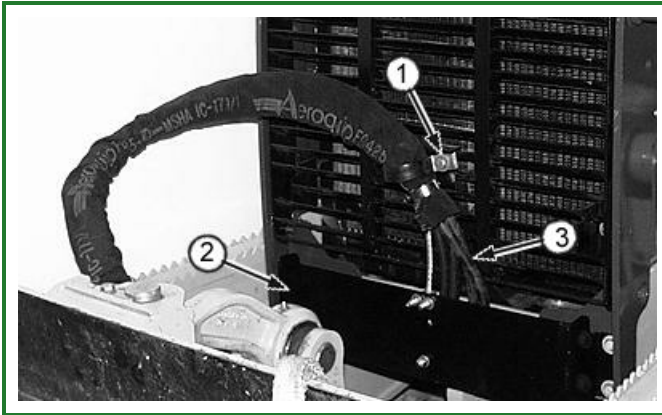

T119392B-UN: Cylinder hoses

LEGEND:

- 1 - Hose Clamp
- 2 - Hose Guard
- 3 - Cylinder Hose (4 used)

Remove clamp (1).

5. Remove hose guard (2).

6.

⚠ CAUTION:



X9811-UN: Fluid Caution

Escaping fluid under pressure can penetrate the skin causing serious injury. Avoid the hazard by relieving pressure before disconnecting hydraulic or other lines. Tighten all connections before applying pressure. Search for leaks with a piece of cardboard. Protect hands and body from high pressure fluids.

If an accident occurs, see a doctor immediately. Any fluid injected into the skin must be surgically removed within a few hours or gangrene may result. Doctors unfamiliar with this type of injury should reference a knowledgeable medical source. Such information is available from Deere & Company Medical Department in Moline, Illinois, U.S.A.

Disconnect four hoses (3). Cap and plug all openings.

7.

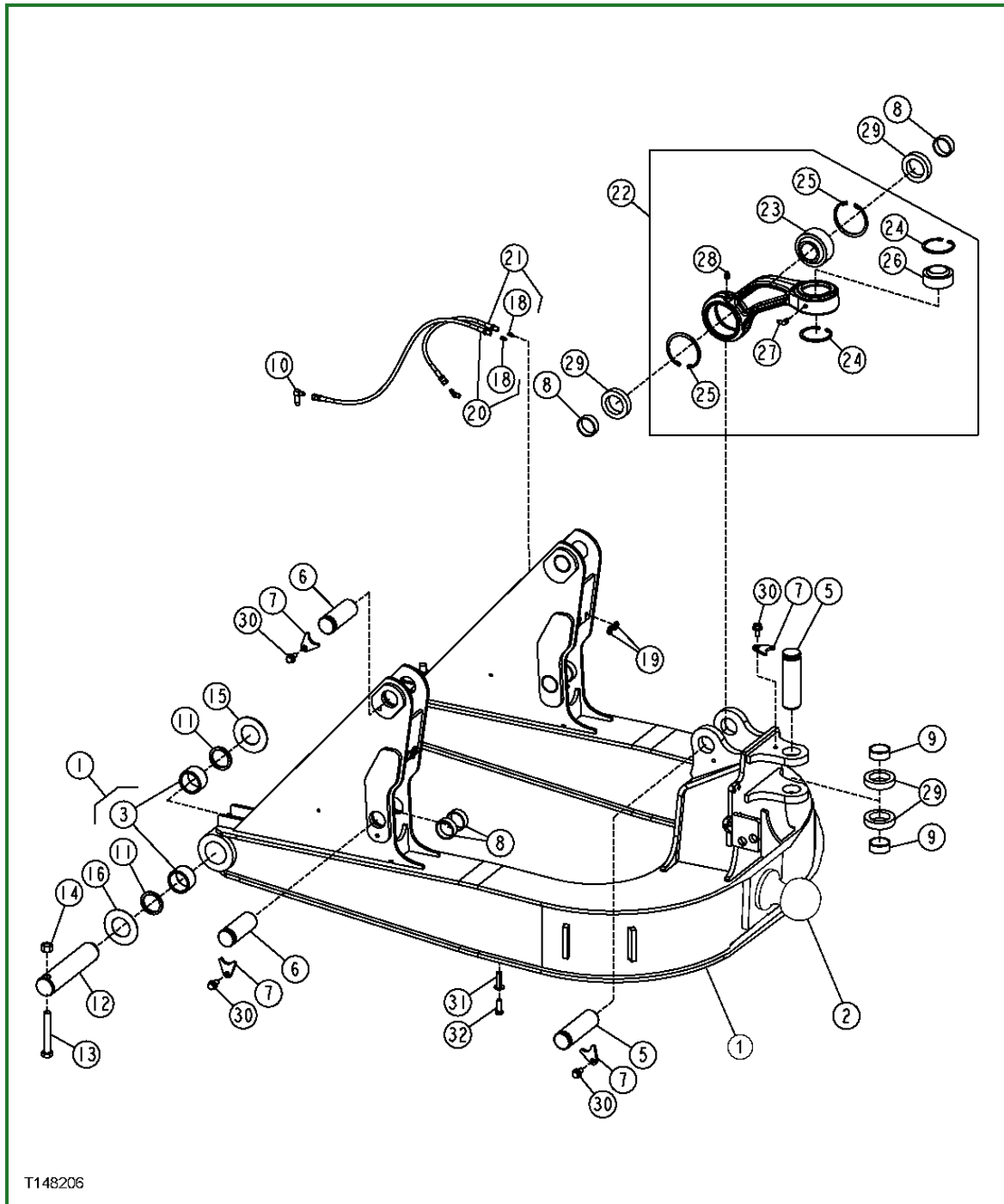

T148206

T148206-UN: Converted C-Frame**LEGEND:**

- 1 - C-Frame
- 2 - Pivot Ball
- 3 - Bushing (4 used)
- 4 - Not Used
- 5 - Pin (2 used)
- 6 - Lift Cylinder Pin (4 used)
- 7 - Pin Retainer (6 used)
- 8 - Bushing (6 used)
- 9 - Bushing (2 used)
- 10 - Elbow Fitting (2 used)
- 11 - Seal (4 used)
- 12 - Pin (2 used)
- 13 - Cap Screw (2 used)

- 14 - Lock Nut (2 used)
- 15 - Washer (2 used)
- 16 - Washer (2 used)
- 17 - Not Used
- 18 - Lubrication Fitting (4 used)
- 19 - Nut (4 used)
- 20 - Lubrication Hose
- 21 - Lubrication Hose
- 22 - Strut Support
- 23 - Bushing
- 24 - Snap Ring (2 used)
- 25 - Snap Ring (2 used)
- 26 - Bushing
- 27 - Lubrication Fitting
- 28 - Lubrication Fitting
- 29 - Bushing (4 used)
- 30 - Cap Screw (6 used)
- 31 - Nut (3 used)
- 32 - Cap Screw (3 used)

Remove lift cylinder pins (6) from rod end of lift cylinders.

8.

⚠ CAUTION:

Prevent possible crushing injury from removing blade. Use proper lifting equipment and safety precautions.

Item	Measurement	Specification
C-Frame		
C-Frame with Blade	Weight	1040 kg 2294 lb
C-Frame	Weight	375 kg 826 lb

Place chains around C-frame or C-frame and blade. Attach a hoist.

- 9. Remove pins (12) and remove C-frame or C-frame and blade.
- 10. Inspect all parts and replace if necessary.
- 11. Install C-frame, C-frame pins, and lifting cylinder rod end pins.
- 12. If cylinder hoses were removed, see [Hydraulic Component Location](#) . (Group 9025-15.)

Go to [Section_32:Group_3240](#)

BT40170,000001C-19-20020617

Hydraulic Control Valve Remove and Install

1.

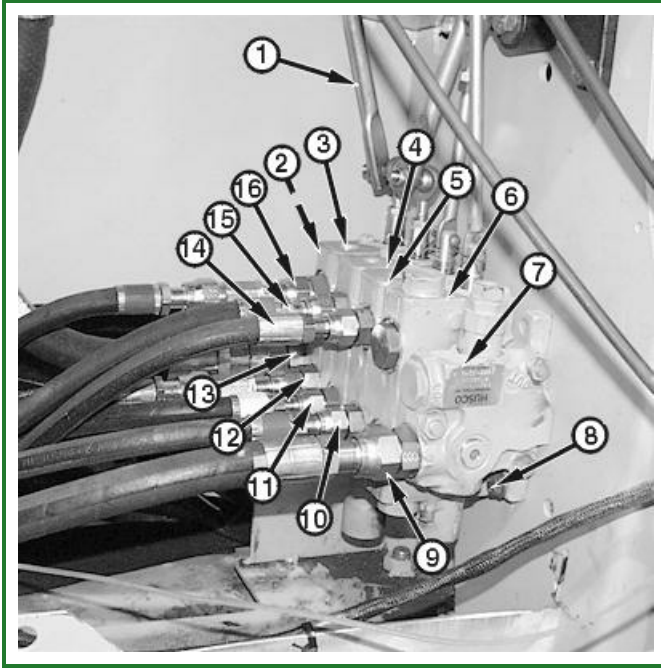

T118949B-UN: Remove Control Valve

LEGEND:

- 1 - Linkage Rods (4 used)
- 2 - Outlet Section
- 3 - Lift Section
- 4 - Tilt Section
- 5 - Angle Section
- 6 - Auxiliary Section
- 7 - Inlet Section
- 8 - Cap Screw (3 used)
- 9 - Inlet Valve-to-Hydraulic Pump Hose
- 10 - Angle Valve-to-Right Angle Cylinder Rod End and Left Cylinder Head End Hose
- 11 - Tilt Valve-to-Tilt Cylinder Head End Hose
- 12 - Lift Valve-to-Lift Cylinders Head End Hose
- 13 - Outlet Valve-to-Hydraulic Filter Hose
- 14 - Angle Valve-to-Left Angle Cylinder Rod End and Right Cylinder Head End Hose
- 15 - Tilt Valve-to-Tilt Cylinder Rod End Hose
- 16 - Lift Valve-to-Lift Cylinders Rod End Hose

Lower all equipment to ground and stop engine.

2. Relieve hydraulic system pressure.
3. Turn battery disconnect switch to OFF.
4. Apply a vacuum to hydraulic reservoir.
5. Disconnect linkage rods (1).
6. Mark and disconnect hoses (9—16). Cap and plug all openings.
7. Remove cap screws (8) and remove control valve.

8. Install control valve using cap screws (8).
9. Connect hoses (9—16).
10. Connect linkage rods (1).
11. Remove vacuum from reservoir.
12. Check and fill hydraulic reservoir as needed.
13. Turn battery disconnect switch to ON.
14. Start machine and check for leaks.

Go to [Section_32:Group_3260](#)

CED, TX03768,2532-19-19990409

Hydraulic Control Valve Remove and Install

1.

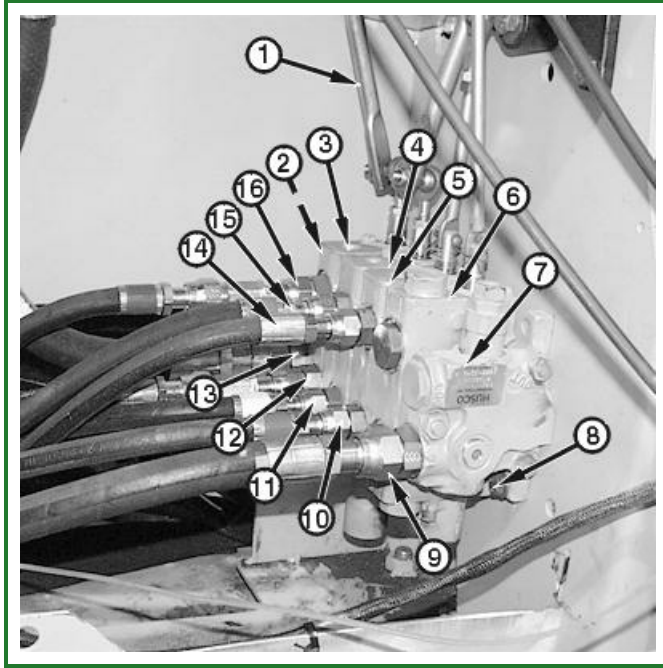

T118949B-UN: Remove Control Valve

LEGEND:

- 1 - Linkage Rods (4 used)
- 2 - Outlet Section
- 3 - Lift Section
- 4 - Tilt Section
- 5 - Angle Section
- 6 - Auxiliary Section
- 7 - Inlet Section
- 8 - Cap Screw (3 used)
- 9 - Inlet Valve-to-Hydraulic Pump Hose
- 10 - Angle Valve-to-Right Angle Cylinder Rod End and Left Cylinder Head End Hose
- 11 - Tilt Valve-to-Tilt Cylinder Head End Hose
- 12 - Lift Valve-to-Lift Cylinders Head End Hose
- 13 - Outlet Valve-to-Hydraulic Filter Hose
- 14 - Angle Valve-to-Left Angle Cylinder Rod End and Right Cylinder Head End Hose
- 15 - Tilt Valve-to-Tilt Cylinder Rod End Hose
- 16 - Lift Valve-to-Lift Cylinders Rod End Hose

Lower all equipment to ground and stop engine.

2. Relieve hydraulic system pressure.
3. Turn battery disconnect switch to OFF.
4. Apply a vacuum to hydraulic reservoir.
5. Disconnect linkage rods (1).
6. Mark and disconnect hoses (9—16). Cap and plug all openings.
7. Remove cap screws (8) and remove control valve.

8. Install control valve using cap screws (8).
9. Connect hoses (9—16).
10. Connect linkage rods (1).
11. Remove vacuum from reservoir.
12. Check and fill hydraulic reservoir as needed.
13. Turn battery disconnect switch to ON.
14. Start machine and check for leaks.

Go to [Section_32:Group_3260](#)

CED, TX03768,2532-19-19990409

Hydraulic Control Valve Disassemble and Assemble

1. IMPORTANT:

Keep all components for each valve section together as a set.

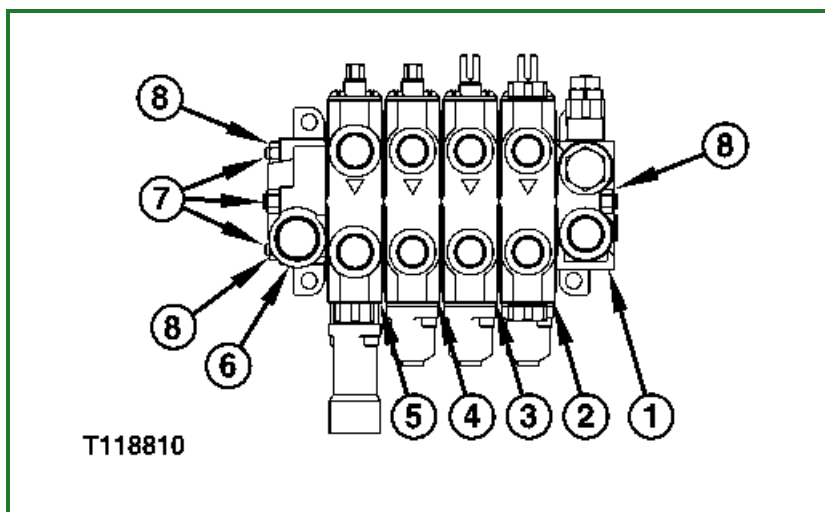

T118810-UN: Control Valve

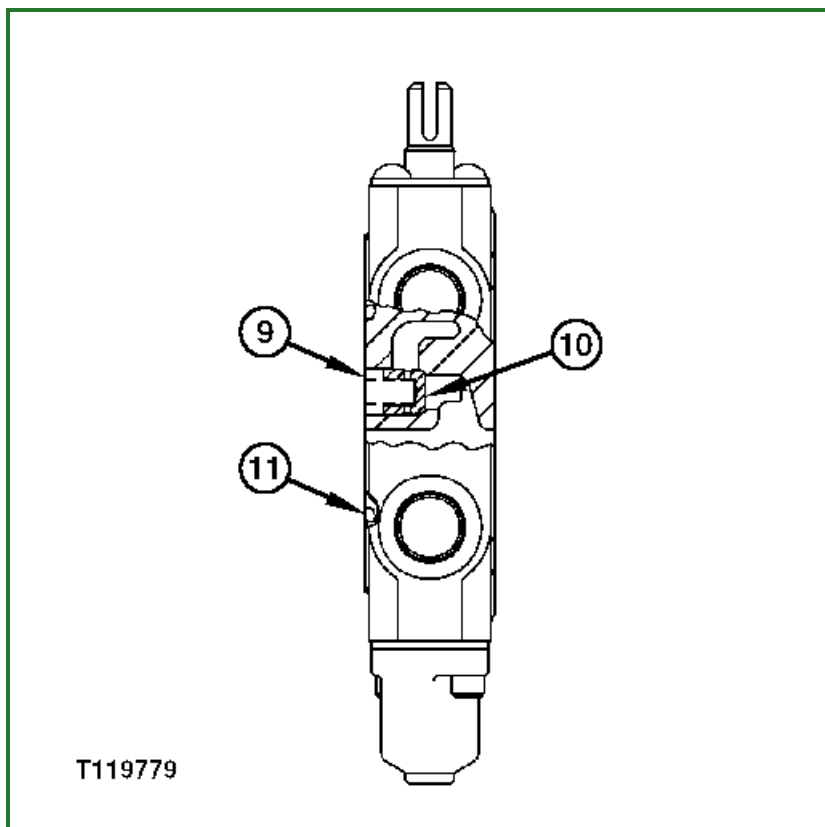

T119779-UN: Control Valve Section

LEGEND:

- 1 - Inlet Section
- 2 - Auxiliary Section
- 3 - Angle Section
- 4 - Tilt Section
- 5 - Lift Section
- 6 - Outlet Section
- 7 - Tie Rod (3 used)

- 8 - Nut (6 used)
- 9 - Spring (1 in each spool section)
- 10 - Load Check (1 in each spool section)
- 11 - O-Ring (1 between each section)

To aid in assembly, identify each section with a mark.

2. Place valve in a vertical position having the inlet section down and supported by wood blocks.
3. Remove nuts (8) and tie rods (7).
4. Carefully remove sections (1—6). Do not lose or damage O-rings (11), load checks (10), and springs (9). Keep load checks and valve sections together as a set.
5. **IMPORTANT:**
Use care not to damage or score mating surfaces of valve sections.
Inspect O-rings between each section for wear or damage. Replace as necessary.
6. Inspect springs and load checks for scoring, wear, or damage. Replace as necessary.
7. Apply clean hydraulic oil to all internal parts.
8. Install load check (10), spring (9), and O-ring (11) into each spool section.
9. Assemble sections (1—6), making sure load checks (10), springs (9), and O-rings (11) remain in position.
10. **IMPORTANT:**
Tighten tie rod and nuts evenly to prevent valve spool binding or leakage between sections.
Evenly tighten tie rod nuts (8) to specifications.

Item	Measurement	Specification
Hydraulic Control Valve		
Control Valve Assembly (5/16 in.) Tie Rod Nuts	Torque	24.4 N·m 216 lb-in
Control Valve Assembly (3/8 in.) Tie Rod Nuts	Torque	45 N·m 33 lb-ft
Control Valve Assembly (7/16 in.) Tie Rod Nuts	Torque	65 N·m 48 lb-ft
Control Valve Assembly (1/2 in.) Tie Rod Nuts	Torque	100.0 N·m 74 lb-ft

Go to [Section_32:Group_3260](#)

CED, TX03768, 2527-19-20150610

Wiper Seals and Lip Seals on Hydraulic Control Valve Remove and Install

1.

NOTE:

Replace cap end seals first and tang end seals second. On cap ends, hold tang ends together by placing a screwdriver through tang ends linkage holes.

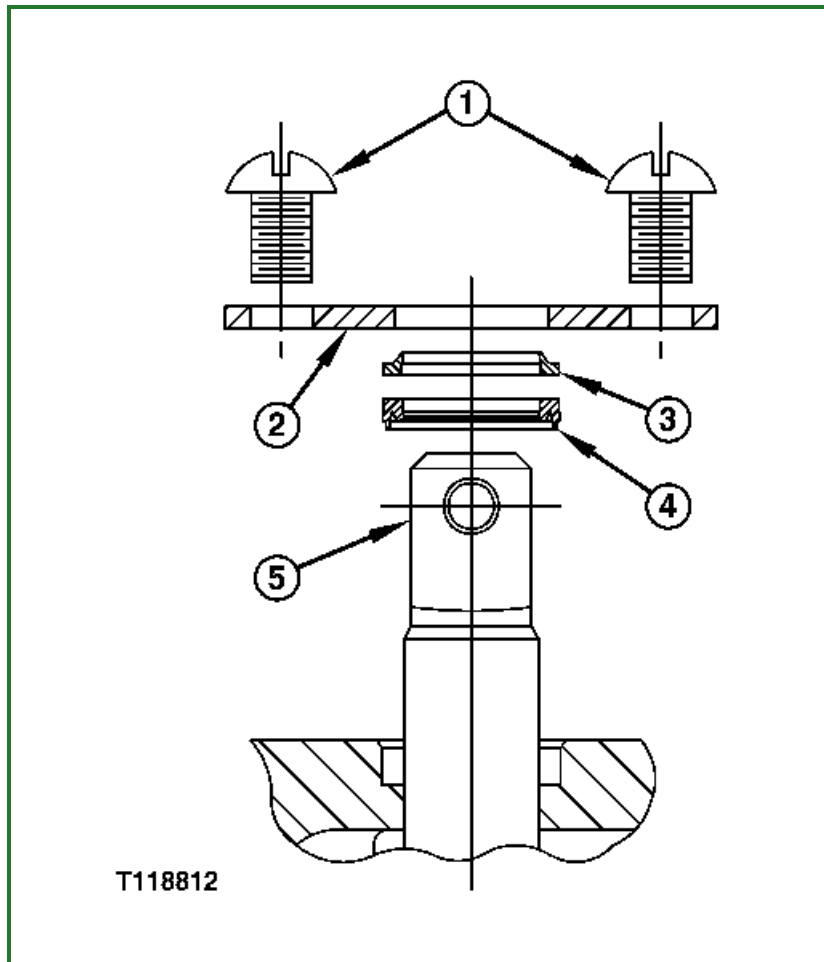

T118812-UN: Wiper and Lip Seal Assembly

LEGEND:

- 1 - Screw (2 used)
- 2 - Retainer Plate
- 3 - Wiper Seal
- 4 - Lip Seal
- 5 - Spool

Remove screws (1) and retainer plate (2) from valve section.

2. Use an O-ring pick to remove wiper seal (3) and lip seal (4).

3.

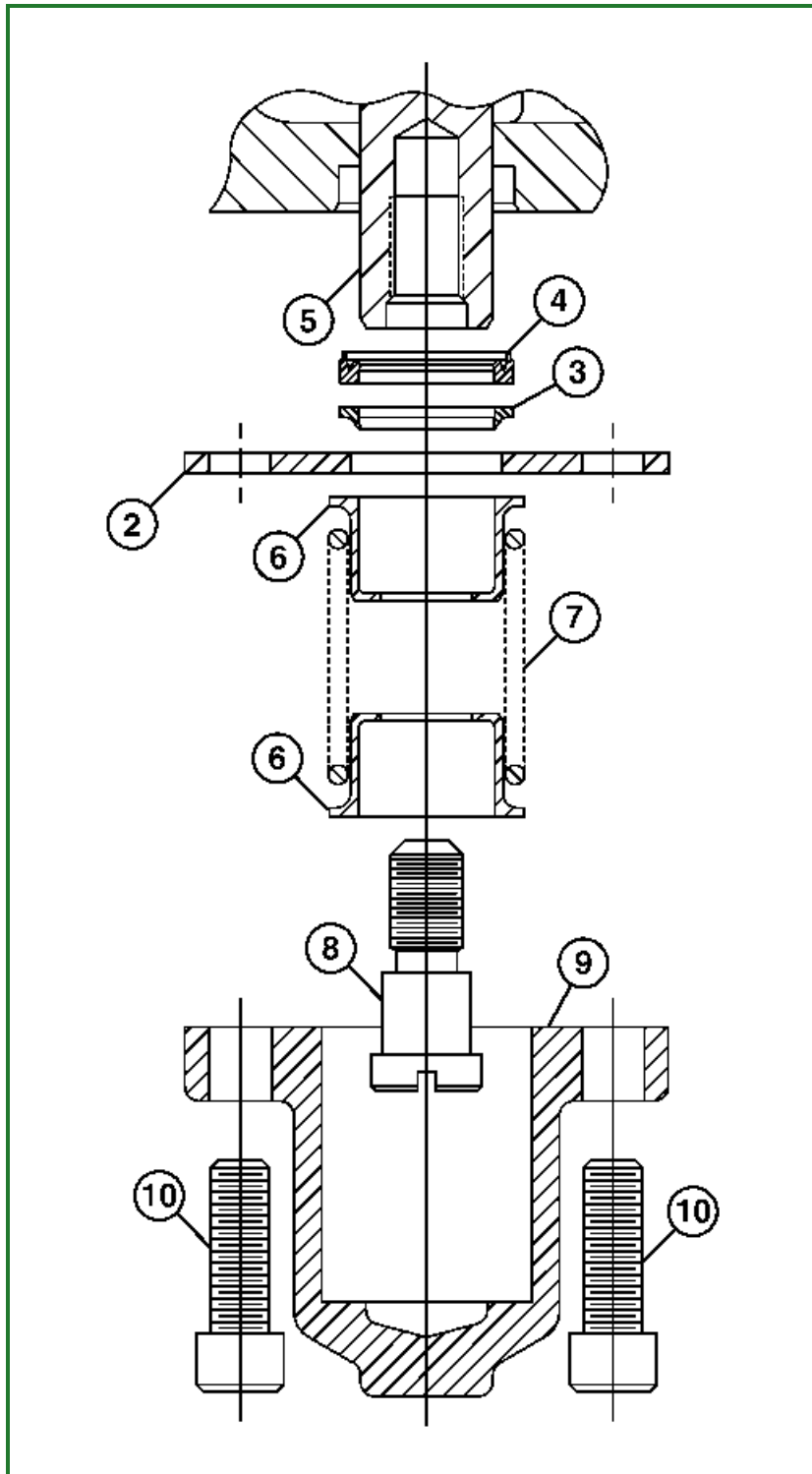

TX1060104-UN: Wiper, Lip Seal and Spool Assembly

LEGEND:

- 2 - Retainer Plate
- 3 - Wiper Seal
- 4 - Lip Seal
- 5 - Spool
- 6 - Spring Seat (2 used)
- 7 - Centering Spring
- 8 - Spool End Screw
- 9 - Cap
- 10 - Socket Head Cap Screw (2 used)

Remove socket head cap screws (10) and cap (9) from valve section.

4. Remove spool end screw (8), spring seats (6), centering spring (7), and retainer plate (2).

4. Remove spool end screw (8), spring seats (6), centering spring (7) and retainer plate (2).
5. Use an O-ring pick to remove wiper seal (3) and lip seal (4).
6. IMPORTANT:

Avoid damage to OD or ID of new lip seal during installation. JDG10583 Seal Installation Tool MUST be used to install lip seal and wiper seal.

NOTE:

Tang (12) of JDG10583 Seal Installation Tool compresses the seal to prevent air from being trapped under it during installation.

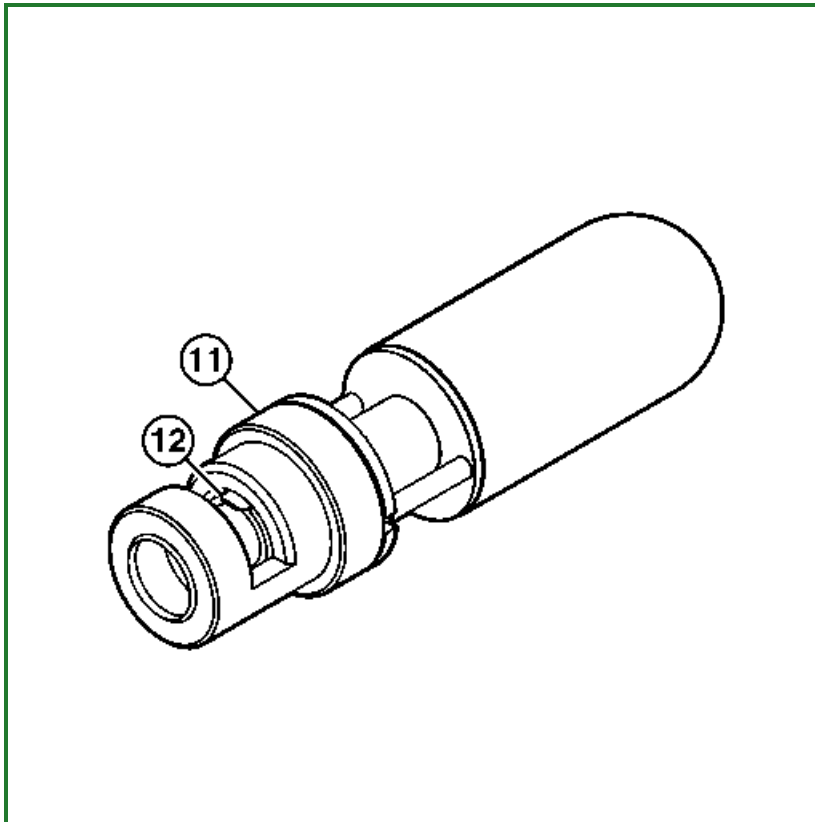

TX1060098-UN: JDG10583 Seal Installation Tool



TX1060099A-UN: JDG10583 Seal Installation Tool

LEGEND:

4 - Lip Seal

11 - JDG10583 Seal Installation Tool

12 - Tang

Lube lip seal (4) and place lip seal into JDG10583 Seal Installation Tool (11) with open side of seal away from tool.

7. Place seal installation tool over end of spool.

8.

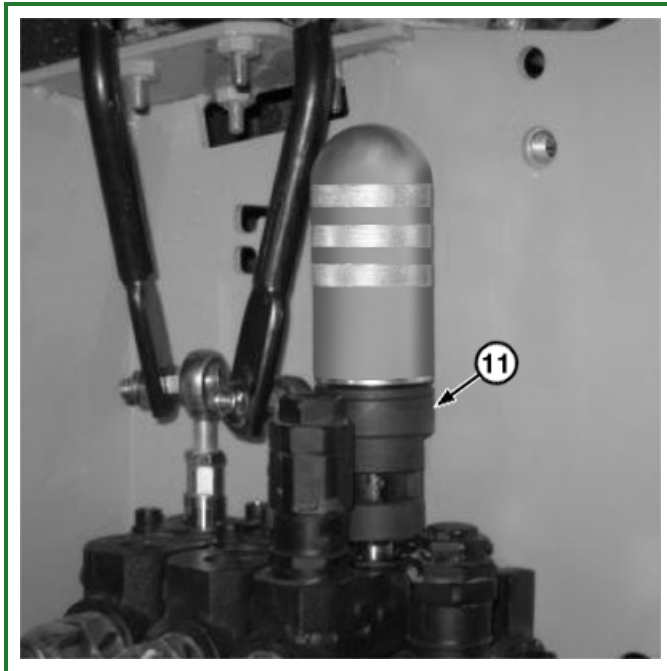

TX1060101A-UN: JDG10583 Seal Installation Tool

LEGEND:

11 - JDG10583 Seal Installation Tool

Push seal installation tool (11) to install lip seal into counterbore of valve housing.

9. Lube wiper seal and place wiper seal into seal installation tool with smaller OD of wiper seal into tool.

10. Place seal installation tool over end of spool.

11. IMPORTANT:

Avoid damage to the wiper seal during assembly. The wiper seal must sit flush just below the surface of the valve housing

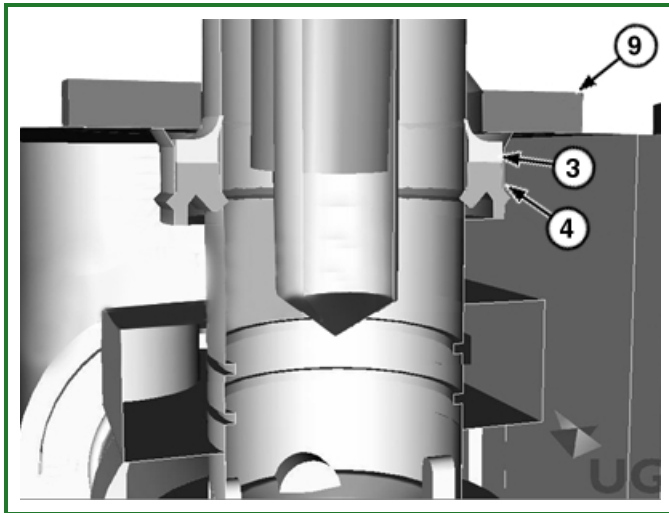

TX1060103A-UN: Seal Installation

LEGEND:

3 - Wiper Seal

4 - Lip Seal

9 - Cap

Push seal installation tool to install wiper seal (3) into counterbore just below surface of valve housing.

12.

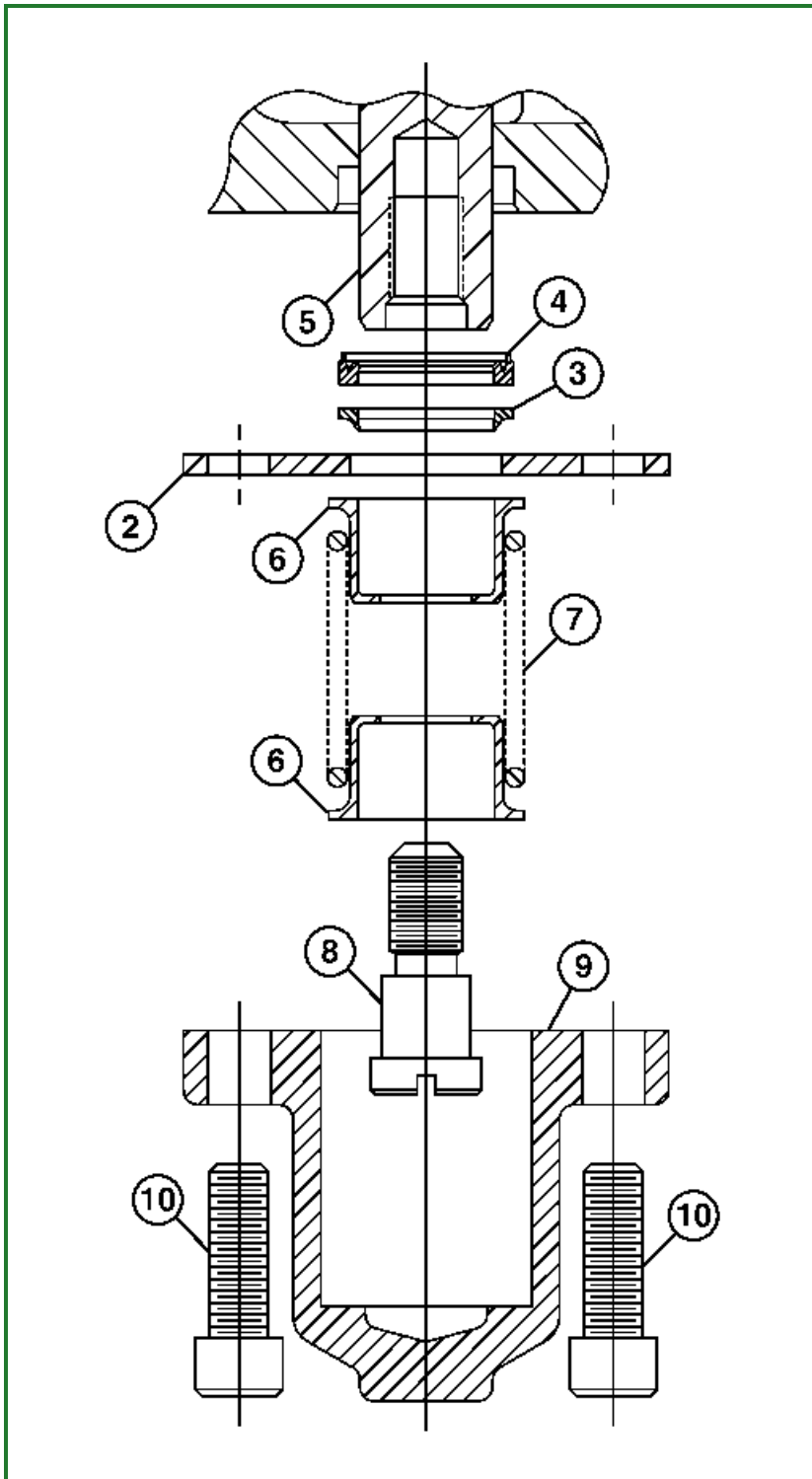

TX1060104-UN: Wiper, Lip Seal and Spool Assembly

LEGEND:

- 2 - Retainer Plate
- 3 - Wiper Seal
- 4 - Lip Seal
- 5 - Spool
- 6 - Spring Seat (2 used)
- 7 - Centering Spring
- 8 - Spool End Screw
- 9 - Cap
- 10 - Socket Head Cap Screw (2 used)

Install retainer plate (2), spring seats (6) and centering spring (7).

13. Clean threads of spool (5) and spool end screw (8). Apply DM37500 Grease. Drive to threads.

13. Clean threads of spool (5) and spool end screw (8). Apply PM3/509 Cure Primer to threads.

14. Apply PM37421 Thread Lock and Sealer (high strength) to threads of spool end screw (8). Install and tighten spool end screw to specification.

Item	Measurement	Specification
Hydraulic Control Valve		
Valve Spool End Screw Torque		9.5 N·m 84 lb.-in.

15. Install cap (9) and socket head cap screws (10). Tighten to specification.

Item	Measurement	Specification
Hydraulic Control Valve		
Valve Spool Cap Socket Head Screws Torque		9.5 N·m 84 lb.-in.

16.

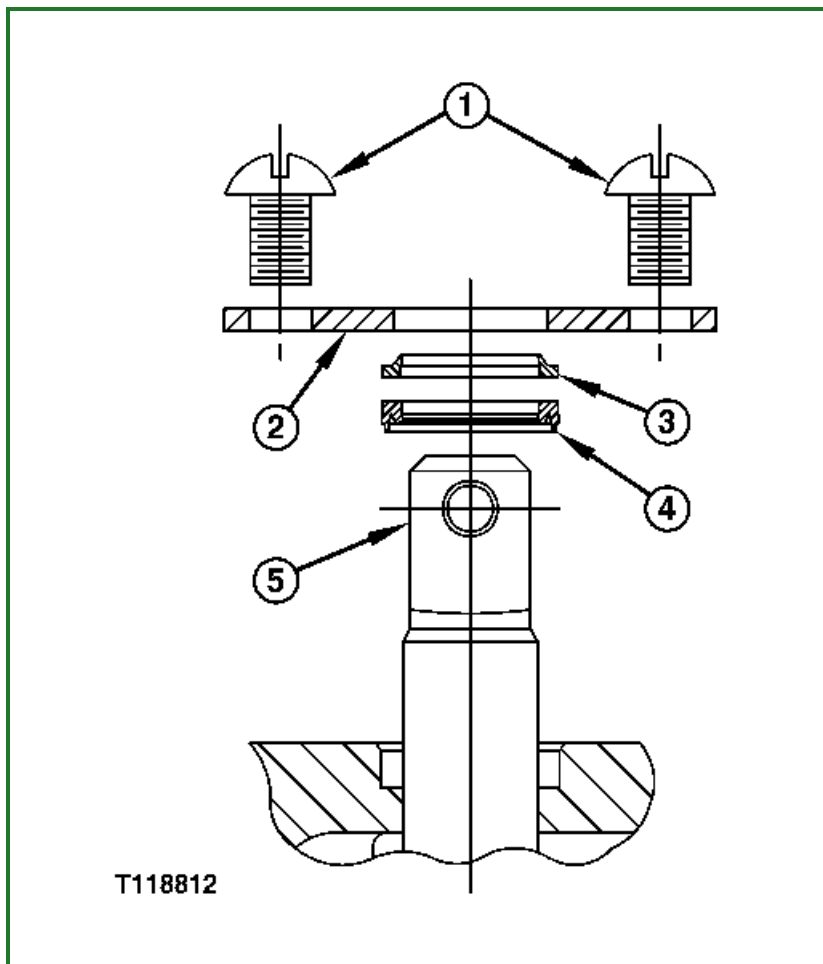

T118812-UN: Wiper and Lip Seal Assembly

LEGEND:

- 1 - Screw (2 used)
- 2 - Retainer Plate
- 3 - Wiper Seal
- 4 - Lip Seal
- 5 - Spool

Install retainer plate (2) and screws (1). Tighten to specification.

Item	Measurement	Specification
Hydraulic Control Valve		
Valve Spool Retainer Plate Screws	Torque	5.5 N·m 48 lb.-in.

17. Check for correct installation of seals by pushing down on spool (5). Spool must return to neutral position.

Go to [Section_32:Group_3260](#)

CED, TX03768, 2528-19-20090710

Auxiliary Control Valve Section Disassemble and Assemble

1. IMPORTANT:

Spool must be installed into the valve housing the same way it was removed for proper operation of the hydraulic function.

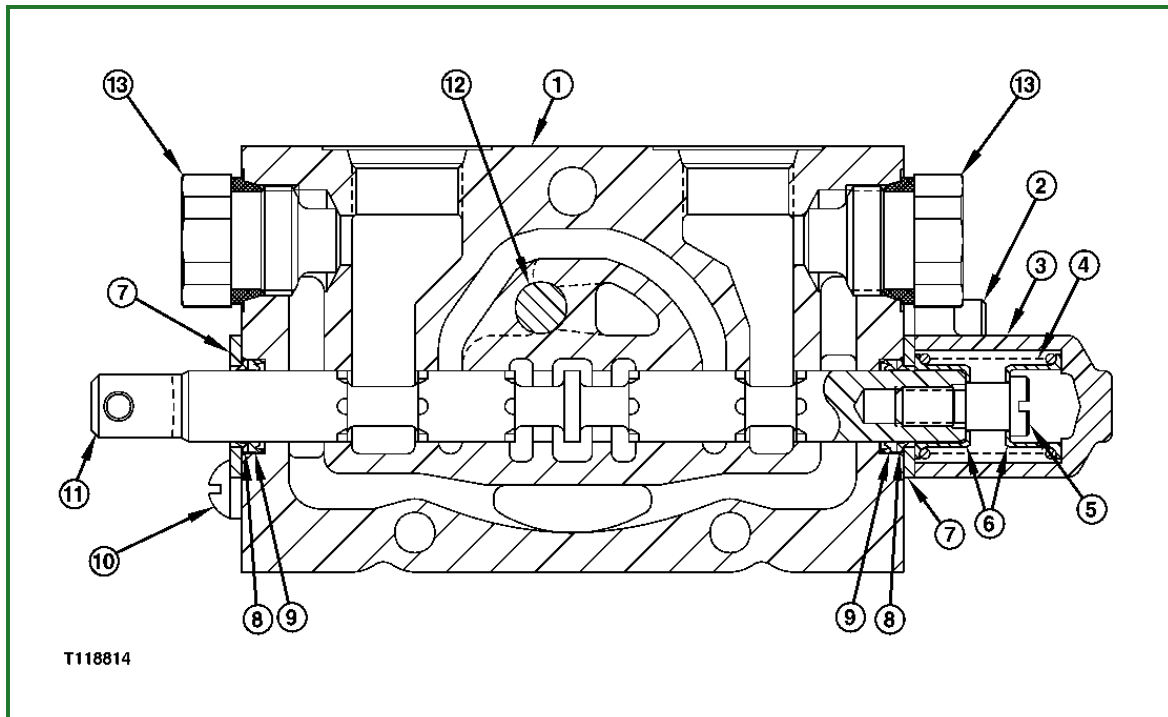

T118814-UN: Control Valve Auxiliary Section

LEGEND:

- 1 - Valve Housing
- 2 - Cap Screw (2 used)
- 3 - Cap
- 4 - Centering Spring
- 5 - Spool End Screw
- 6 - Spring Seat (2 used)
- 7 - Retaining Plate (2 used)
- 8 - Wiper Seal (2 used)
- 9 - Lip Seal (2 used)
- 10 - Screw (2 used)
- 11 - Spool
- 12 - Load Check and Spring
- 13 - Shutoff Plug (2 used)

Remove parts (2, 3, 7, 10 and 11) from valve housing (1).

2. Using a protective cover or wooden blocks, put spool in vise. Remove spool end screw (5), centering spring (4) and spring seats (6).
3. Inspect parts for wear or damage. Replace all O-rings and seals.
4. Put clean hydraulic oil on spool and install spool into valve housing. Install lip seals (9) and wiper seals (8) using JDG10583Seal Installation Tool. [See Wiper Seals and Lip Seals on Hydraulic Control Valve Remove and Install](#) . (Group 3260.)

5. Install parts (4—7) on spool. Clean threads of spool and spool end screw. Apply PM37509 Cure Primer to threads. Apply PM37421 Thread Lock and Sealer (high strength) on spool end screw. Install and tighten screw to specification.

Item	Measurement	Specification
Hydraulic Control Valve		
Auxiliary Valve Spool End Screw	Torque	9.5 N·m 84 lb.-in.

6. Apply grease on centering spring (4).
7. Assemble remaining parts. Tighten cap screws (2), screws (10) and shutoff plugs (13) to specifications.

Item	Measurement	Specification
Hydraulic Control Valve		
Auxiliary Valve Spool Cap Socket Head Screws	Torque	9.5 N·m 84 lb.-in.
Auxiliary Valve Retainer Plate Screws	Torque	5.5 N·m 48 lb.-in.
Auxiliary Valve Shutoff Plugs	Torque	45 N·m 33 lb.-ft.

Go to [Section_32:Group_3260](#)

CED,OUTX547,200-19-20090729

Angle Control Valve Section Disassemble and Assemble

1. IMPORTANT:

Spool must be installed into the valve housing the same way it was removed for proper operation of the hydraulic function.

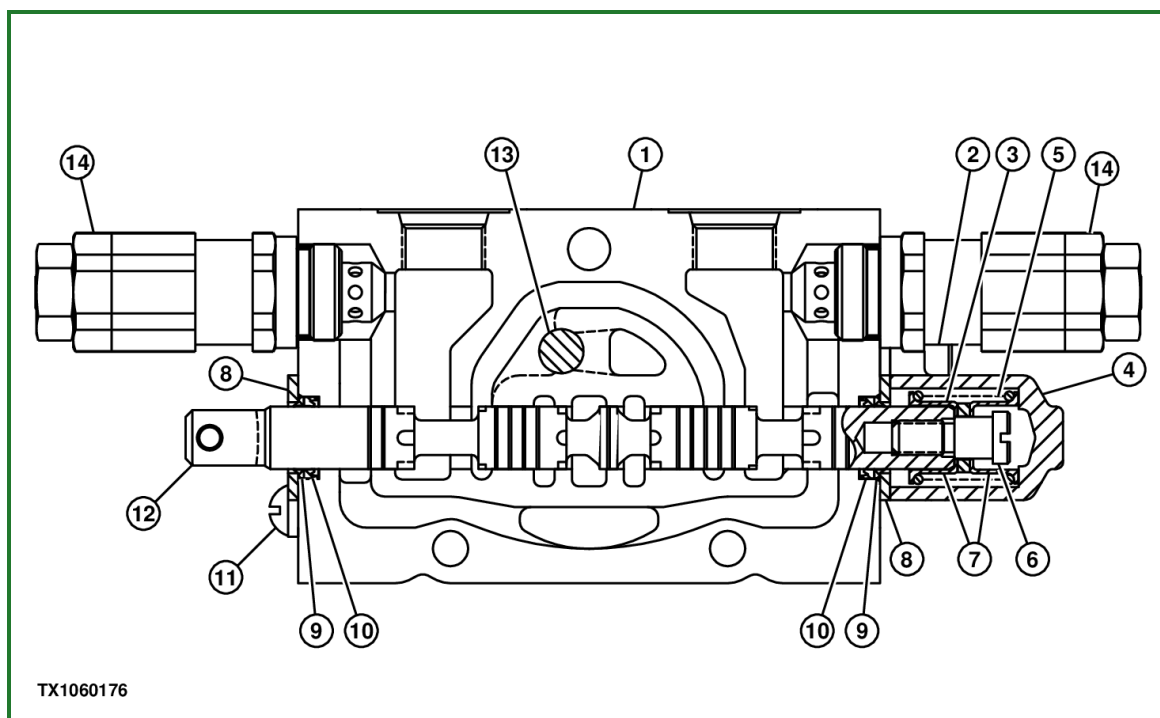

TX1060176-UN: Control Valve Angle Section

LEGEND:

- 1 - Valve Housing
- 2 - Cap Screw (2 used)
- 3 - Spacer
- 4 - Cap
- 5 - Centering Spring
- 6 - Spool End Screw
- 7 - Spring Seat (2 used)
- 8 - Retaining Plate (2 used)
- 9 - Wiper Seal (2 used)
- 10 - Lip Seal (2 used)
- 11 - Screw (2 used)
- 12 - Spool
- 13 - Load Check and Spring
- 14 - Work Port Relief Valve (2 used)

Remove parts (2, 4, 8, and 11) and spool (12) from valve housing (1).

2. IMPORTANT:

To avoid changing adjustment, do not loosen adjustment screw on end of relief.

Remove work port relief valves (14).

3. Using a protective cover or wooden blocks, place spool in vise. Remove spool end screw (6), spacer (3), centering spring (5) and spring seats (7).

4. Inspect parts for wear or damage. Replace all O-rings and seals.
5. Put clean hydraulic oil on spool and install spool into valve housing (1). Install lip seals (10) and wiper seals (9) using JDG10583Seal Installation Tool. [See Wiper Seals and Lip Seals on Hydraulic Control Valve Remove and Install](#) . (Group 3260.)
6. Install parts (3 and 5—8) on spool. Clean threads of spool and spool end screw. Apply PM37509 Cure Primer to threads. Apply PM37421 Thread Lock and Sealer (high strength) on spool end screw. Install and tighten spool end screw to specification.

Item	Measurement	Specification
Hydraulic Control Valve		
Angle Valve Spool End Screw Torque		9.5 N·m 84 lb.-in.

7. Apply grease to centering spring (5).
8. Assemble remaining parts. Tighten cap screws (2) and screws (11) to specifications.

Item	Measurement	Specification
Hydraulic Control Valve		
Angle Valve Spool Cap Socket Head Screws	Torque	9.5 N·m 84 lb.-in.
Angle Valve Retainer Plate Screws	Torque	5.5 N·m 48 lb.-in.

9. IMPORTANT:

Tightening work ports relief using jam nut on end of relief will cause damage to work ports relief. Do not tighten work ports relief using jam nut on end of relief.

Assemble work ports reliefs (14) into housing (1). Tighten reliefs to specification.

Item	Measurement	Specification
Hydraulic Control Valve		
Angle Valve Circuit Relief Torque		41—49 N·m 30—36 lb.-ft.

Go to [Section_32:Group_3260](#)

CED,OUO1004,533-19-20090714

Tilt Control Valve Section Disassemble and Assemble

1. IMPORTANT:

Spool must be installed into the valve housing the same way it was removed for proper operation of the hydraulic function.

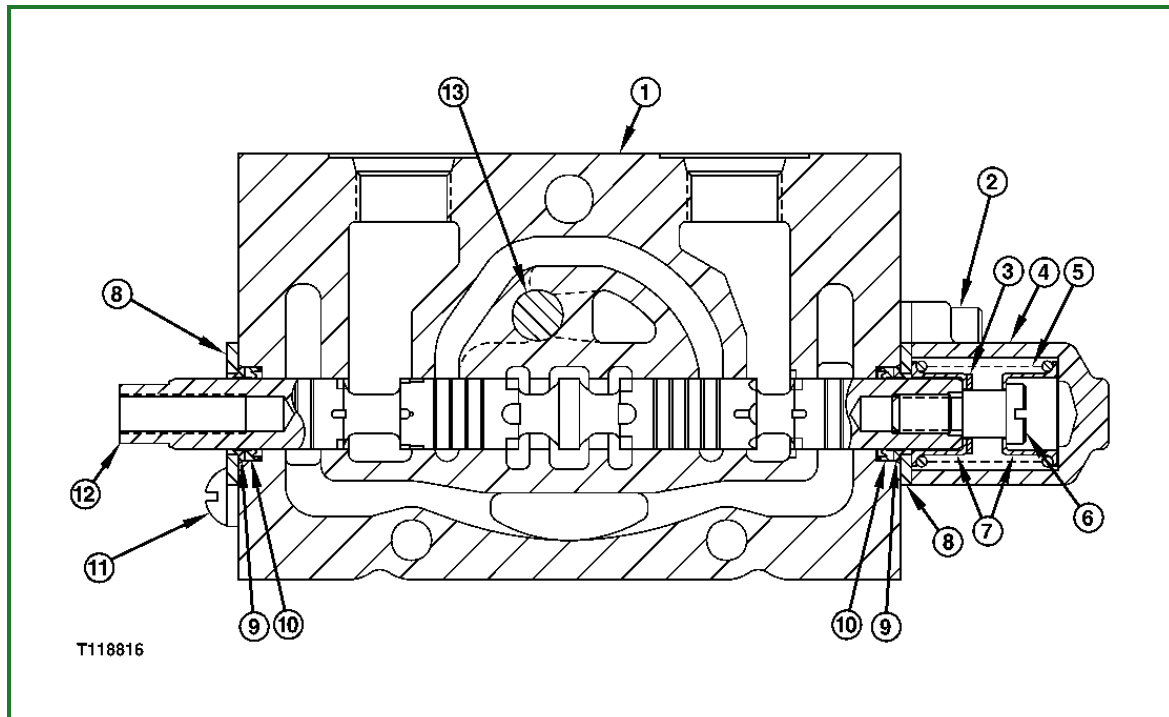

T118816-UN: Control Valve Tilt Section

LEGEND:

- 1 - Valve Housing
- 2 - Cap Screw (2 used)
- 3 - Spacer
- 4 - Cap
- 5 - Centering Spring
- 6 - Spool End Screw
- 7 - Spring Seat (2 used)
- 8 - Retaining Plate (2 used)
- 9 - Wiper Seal (2 used)
- 10 - Lip Seal (2 used)
- 11 - Screw (2 used)
- 12 - Spool
- 13 - Load Check and Spring

Remove parts (2, 4, 8, 11 and 12) from valve housing (1).

2. Using a protective cover or wooden blocks, place spool in vise. Remove spool end screw (6), spacer (3), centering spring (5) and spring seats (7).
3. Inspect parts for wear or damage. Replace all O-rings and seals.
4. Put clean hydraulic oil on spool and install spool into valve housing. Install lip seals (10) and wiper seals (9) using JDG10583Seal Installation Tool. [See Wiper Seals and Lip Seals on Hydraulic Control Valve Remove and Install](#) . (Group 3260.)

5. Install parts (3 and 5—8) on spool. Clean threads of spool and spool end screw. Apply PM37509 Cure Primer to threads. Apply PM37421 Thread Lock and Sealer (high strength) on spool end screw (6). Install and tighten tilt valve spool end screw to specification.

Item	Measurement	Specification
Hydraulic Control Valve		
Tilt Valve Spool End Screw	Torque	9.5 N·m 84 lb.-in.

6. Apply grease to centering spring (5).
7. Assemble remaining parts. Tighten cap screws (2) and screws (11) to specifications.

Item	Measurement	Specification
Hydraulic Control Valve		
Tilt Valve Spool Cap Socket Head Screws	Torque	9.5 N·m 84 lb.-in.
Tilt Valve Retainer Plate Screws	Torque	5.5 N·m 48 lb.-in.

Go to [Section_32:Group_3260](#)

CED,OUO1004,534-19-20090729

Lift Control Valve Section Disassemble and Assemble

1. IMPORTANT:

For proper valve disassembly, spool should be in center (neutral) position, not the detent position. Spool must be installed into the valve housing the same way it was removed for proper operation of the hydraulic function.

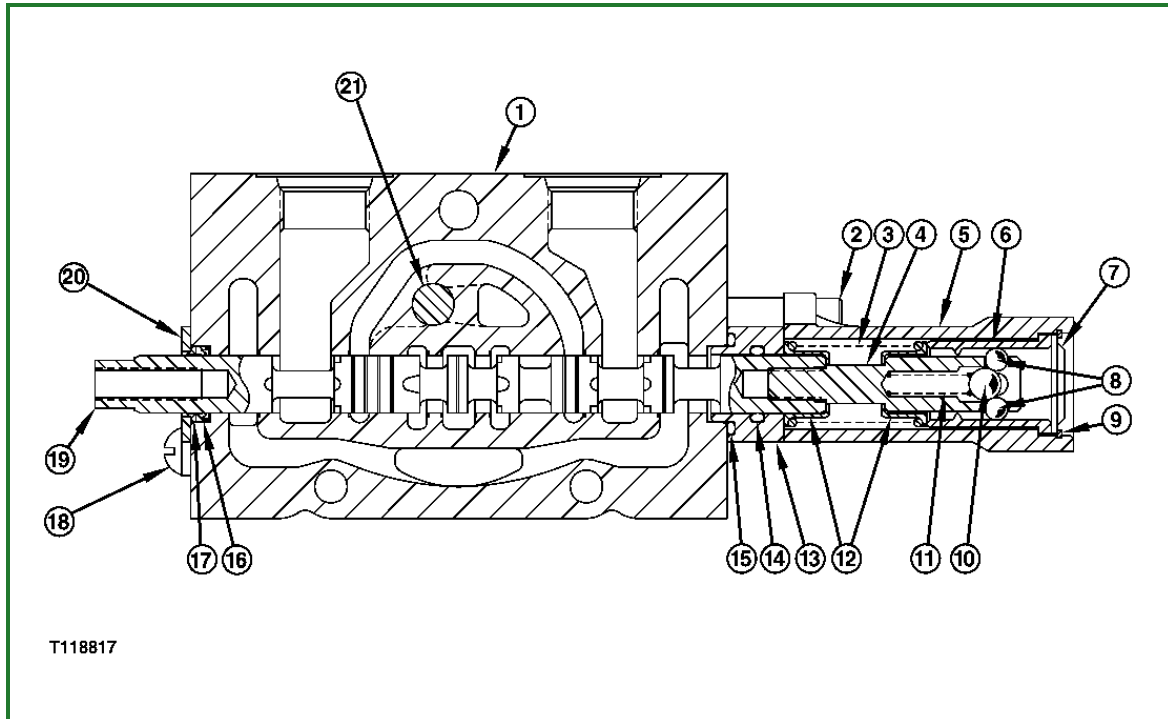

T118817-UN: Control Valve Lift Section

LEGEND:

- 1 - Valve Housing
- 2 - Cap Screw (2 used)
- 3 - Centering Spring
- 4 - Detent Spool End Screw
- 5 - Cap
- 6 - Detent Sleeve
- 7 - Spacer
- 8 - Small Detent Ball (4 used)
- 9 - Retainer Ring
- 10 - Large Detent Ball
- 11 - Detent Spring
- 12 - Spring Seat (2 used)
- 13 - Cap Spacer
- 14 - O-Ring
- 15 - O-Ring
- 16 - Lip Seal
- 17 - Wiper Seal
- 18 - Screw (2 used)
- 19 - Spool
- 20 - Retainer Plate
- 21 - Check Valve and Spring

Remove retainer ring (9) with a screwdriver and spacer (7). Remove parts (2, 18, and 20). The spool (19) and whole end assembly (3—6, 8 and 10—15) can now be removed from the valve housing (1).

2.

NOTE:

Use a catch pan under valve spool assembly for catching four small detent balls (8) during procedure.

Using a protective cover or wooden blocks, put spool in vise. Slide detent spool cap (5) and detent sleeve (6) off of detent spool end screw (4) until detent sleeve is stopped by detent balls (8). Push a 3.8 mm (0.125 in.) punch through detent sleeve into detent spool end screw (4) and depress large detent ball (10) against detent spring (11). This will retract the four small detent balls (8) to allow full removal of parts (5 and 6). Remove detent sleeve from cap (5).

3. Remove parts (3, 4, 8 and 10—12). Remove detent balls (8 and 10) and detent spring (11) from detent spool end screw (4). Remove parts (13—15) from spool (19) and seals (16 and 17) from valve housing (1).

4. Inspect parts for wear or damage. Replace all O-rings and seals.

5. Put clean hydraulic oil on spool (19) and install spool into valve housing (1). On the spool tang (handle) end, install lip seal (16) and wiper seal (17) using JDG10583 Seal Installation Tool. [See Wiper Seals and Lip Seals on Hydraulic Control Valve Remove and Install](#) . (Group 3260.)

6.

NOTE:

Lubricate O-ring (14) prior to installation to prevent O-ring damage.

On cap end, install cap spacer (13) and O-rings (14 and 15).

7. Clean threads of spool and spool end screw. Apply PM37509 Cure Primer to threads. Apply PM37421 Thread Lock and Sealer (high strength) on threads and assemble spring seats (12), centering spring (3) and detent spool end screw end screw (4) onto end of spool. Tighten spool end screw to specification.

Item	Measurement	Specification
Hydraulic Control Valve		
Lift Valve Spool End Screw	Torque	9.5 N·m 84 lb.-in.

8. Apply grease to centering spring (3).

9. Install detent spring (11) and detent balls (8 and 10) into detent spool end screw (4). Hold small detent balls (8) in place with grease.

10. Slide cap (5) onto spool end. Slide detent sleeve (6) into cap (5), until it touches detent balls (8). Push a 3.18 mm (0.125 in.) punch through detent sleeve (6) into detent spool end screw (4) and depress large detent ball (10) against detent spring (11). This will retract the four detent balls (8) to allow full installation of the detent sleeve (6) over the spool end and inside the cap.

Check to make sure that all four detent balls (8) are in place.

11. Install spacer (7) and retainer ring (9). Install cap screws (2) and tighten to specification.

Item	Measurement	Specification
Hydraulic Control Valve		
Lift Valve Cap Socket Head Cap Screws	Torque	9.5 N·m 84 lb.-in.

12. Install retainer plate (20) and tighten screws (18) to specification.

Item	Measurement	Specification
Hydraulic Control Valve		
Lift Valve Spool Retaining Plate Screws	Torque	5.5 N·m 48 lb.-in.

Go to [Section_32:Group_3260](#)

CED,TX03768,2533-19-20090714

Integrated Grade Control (IGC) Lever Remove and Install (S.N. 130886—)

1.

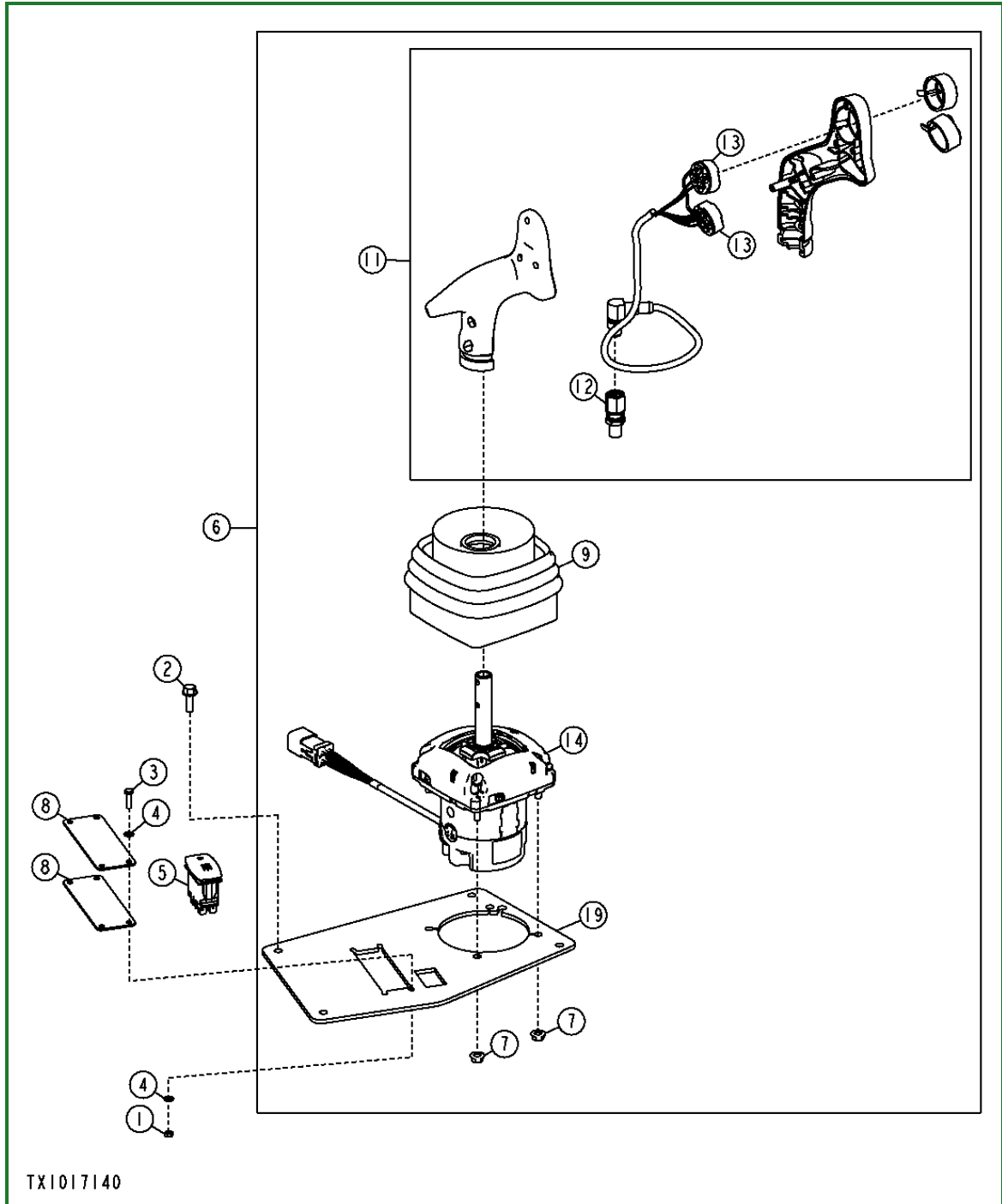

TX1017140-UN: Integrated Grade Control (IGC) Lever Assembly (Joystick) (S.N. 130886-)

LEGEND:

- 1 - Nut (4 Used)
- 2 - Cap Screw (4 Used)
- 3 - Cap Screw (4 Used)
- 4 - Washer (8 Used)
- 5 - STC Adapter Fitting
- 6 - IGC Lever (Joystick) (Complete)
- 7 - Nut (4 Used)
- 8 - Plate
- 9 - Boot
- 10 - Not Used

- 11 - Handle Assembly
- 12 - Electrical Connector
- 13 - Cover
- 14 - Multi-function Controller
- 15 - Not Used
- 16 - Not Used
- 17 - Not Used
- 18 - Not Used
- 19 - Plate

Turn battery disconnect switch to OFF position.

2.

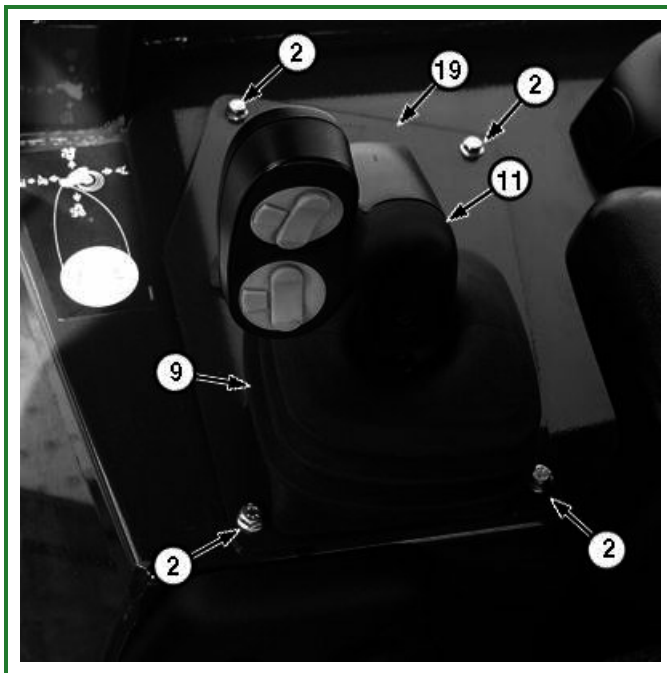

TX1023038A-UN: Integrated Grade Control (IGC) Lever (S.N. 130886-)

Remove four cap screws (2).

3. Lift plate (19) to expose electrical connections.

4.

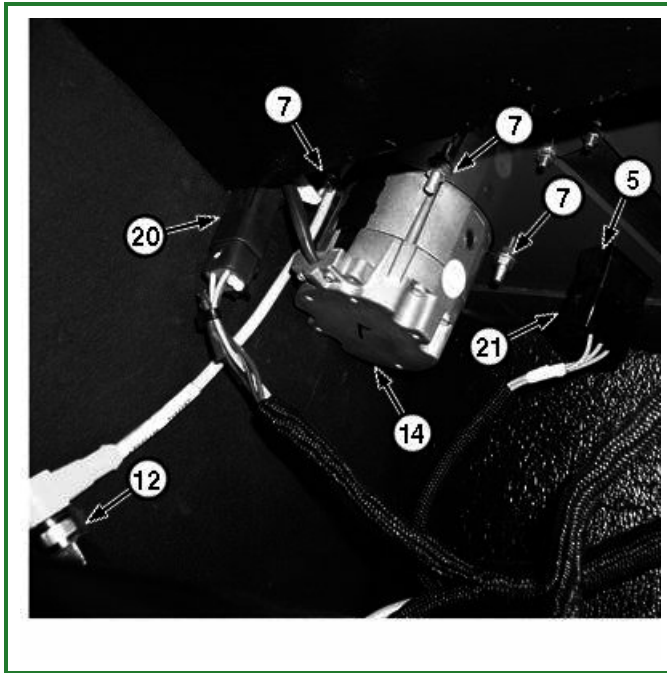

TX1023043A-UN: Integrated Grade Control (IGC) Lever (S.N. 130886-) (from inside right side panel)

Disconnect electrical connections (12, 20, 21) from assembly.

5. Remove complete lever assembly from machine.
6. Remove four nuts (7) from bottom of IGC lever (6) and remove IGC lever from plate.
7. Repair or replace parts as required
8. Install IGC lever (6) in plate (19) using four nuts (7)
9. Connect electrical connections (12, 20, 21)
10. Install IGC lever assembly using four cap screws (2).
11. Turn battery disconnect switch to ON position.
12. Operate machine and verify all functions work correctly.

Go to [Section_32:Group_3260](#)

KV70328,00001E7-19-20070524

Integrated Grade Control (IGC) Lever Disassemble and Assemble (S.N. 130886—)

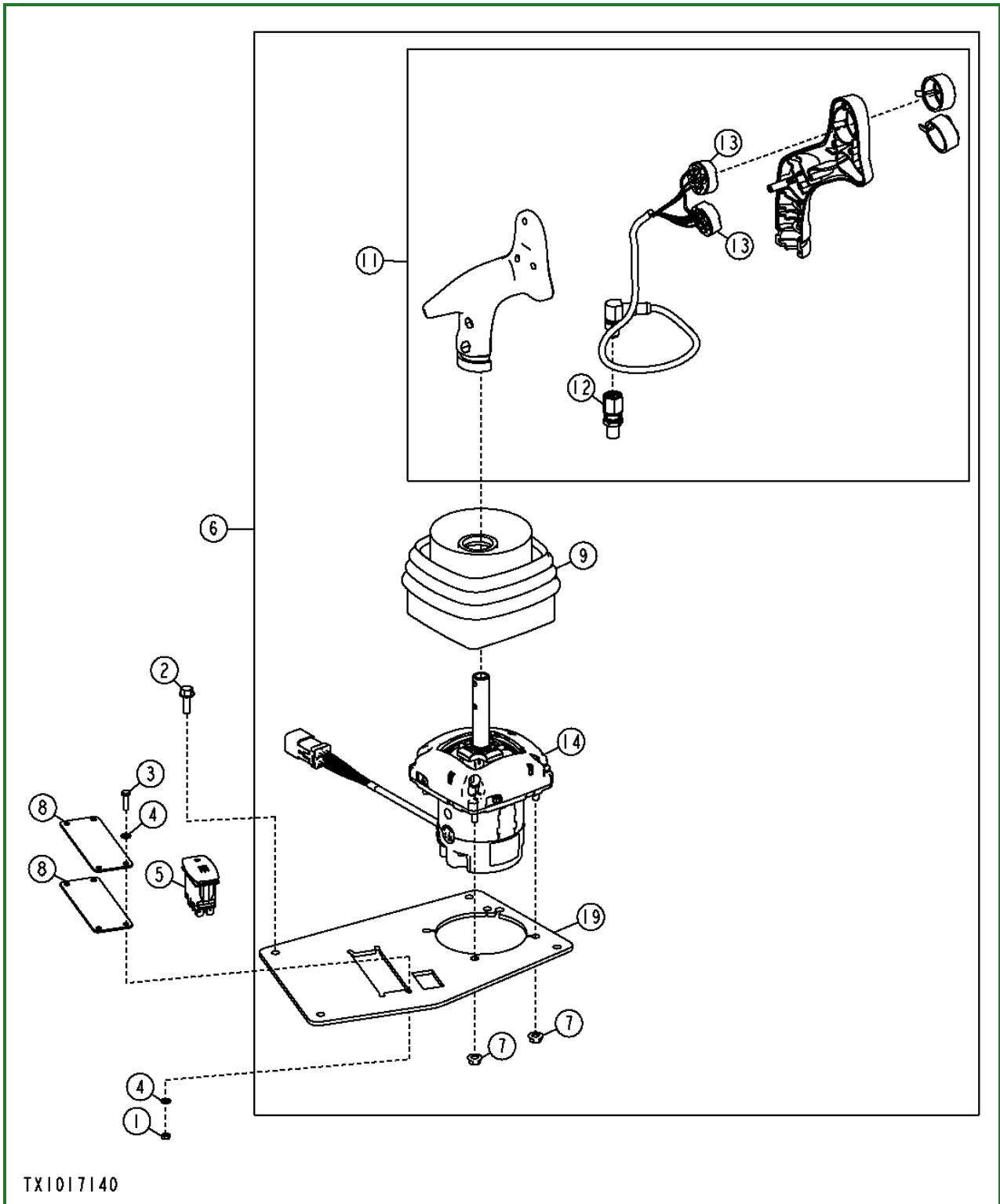

TX1017140-UN: Integrated Grade Control (IGC) Lever Assembly (Joystick) (S.N. 130886-)

LEGEND:

- 1 - Nut (4 Used)
- 2 - Cap Screw (4 Used)
- 3 - Cap Screw (4 Used)
- 4 - Washer (8 Used)
- 5 - STC Adapter Fitting
- 6 - IGC Lever (Joystick) (Complete)
- 7 - Nut (4 Used)

- 8 - Plate
- 9 - Boot
- 10 - Not Used
- 11 - Handle Assembly
- 12 - Electrical Connector
- 13 - Cover
- 14 - Multi-function Controller
- 15 - Not Used
- 16 - Not Used
- 17 - Not Used
- 18 - Not Used
- 19 - Plate

Disassemble and assemble parts as shown.

[Go to Section_32:Group_3260](#)

KV70328,00001E8-19-20070524

System and Angle Circuit Relief Valve Disassemble and Assemble

1.

NOTE:

Only O-rings and backup rings are serviceable as a kit. If other parts are damaged, replace relief valve assembly.

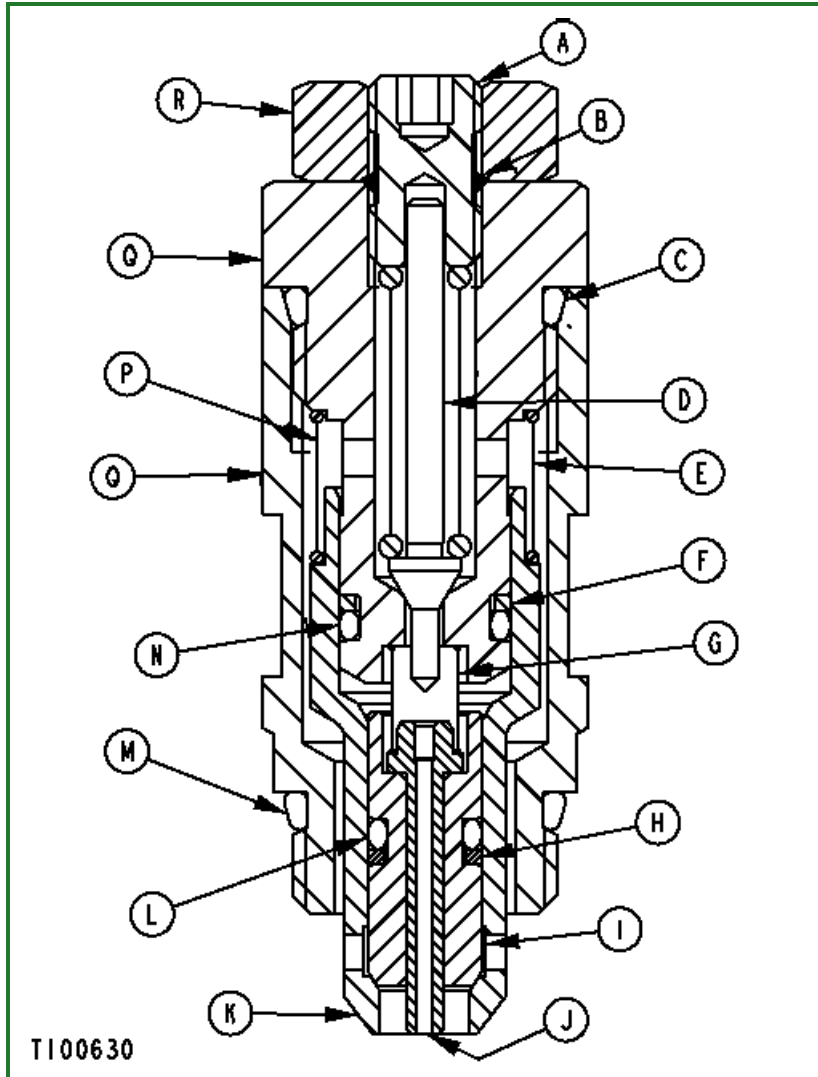

TI00630-UN: System Relief Valve—Cross Section

LEGEND:

- A - Adjusting Screw
- B - O-Ring (2 used)
- C - O-Ring
- D - Pilot Poppet
- E - Spring
- F - Backup Ring
- G - Spring
- H - Backup Ring
- I - Poppet
- J - Piston
- K - Poppet
- L - O-Ring
- M - O-Ring

N - O-Ring

O - Valve Body

P - Spring

Q - Valve Body Plug

R - Nut

Disassemble and inspect parts for wear and damage.

2. Put clean hydraulic oil on all parts before assembly.

3. Adjust system relief valve. [See Hydraulic System Relief Valve Test](#) . (Group 9025-25.)

Go to [Section_32:Group_3260](#)

CED,OUTX547,201-19-20011207

Tilt Cylinder Remove and Install

1. Lower all equipment to the ground.
2. Stop engine. Operate all hydraulic controls to release pressure in hydraulic system.

3.

⚠ CAUTION:

To avoid injury from escaping fluid under pressure, stop engine and relieve the pressure in the system before disconnecting or connecting hydraulic lines. Tighten all connections before applying pressure.



X9811-UN: Fluid Symbol

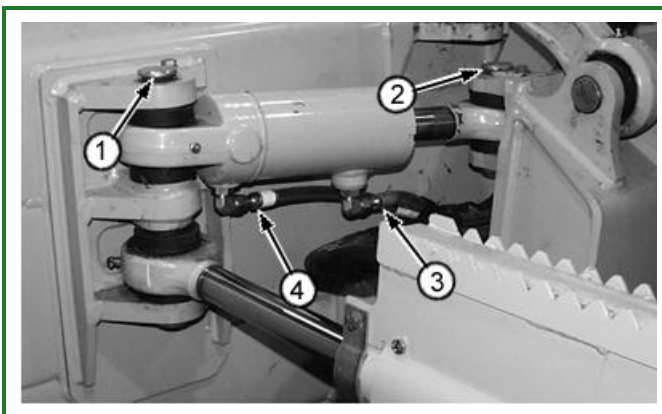

T119484B-UN: Tilt Cylinder

LEGEND:

- 1 - Pin Head End
- 2 - Pin Rod End
- 3 - Cylinder Rod End Hose
- 4 - Cylinder Head End Hose

Tag and mark cylinder hoses (3 and 4).

4. Disconnect cylinder hoses (3 and 4). Cap and plug all openings.
5. Attach cylinder to hoist using lift strap.

6. Remove cap screw, retainer, and pin (2). Remove cap screws and retainers on tilt cylinder head end and angle cylinder rod end. Drive tilt cylinder pin (1) and angle pin out.
7. Remove cylinder.
8. Inspect rubber bushings, replace if necessary. [See Angle, Lift, and Tilt Cylinders Disassemble and Assemble \(John Deere 120 Series Cylinders\)](#) . (Group 3260.)
9. Install cylinder and pins. Connect hoses.

Go to [Section_32:Group_3260](#)

CED,TX03768,2529-19-20090205

Angle Cylinder Remove and Install

1. Lower all equipment to the ground.
2. Stop engine. Operate all hydraulic controls to relieve system pressure.

3.

⚠ CAUTION:

To avoid injury from escaping fluid under pressure, stop engine and relieve the pressure in the system before disconnecting or connecting hydraulic or other lines. Tighten all connections before applying pressure.



X9811-UN: Fluid Symbol

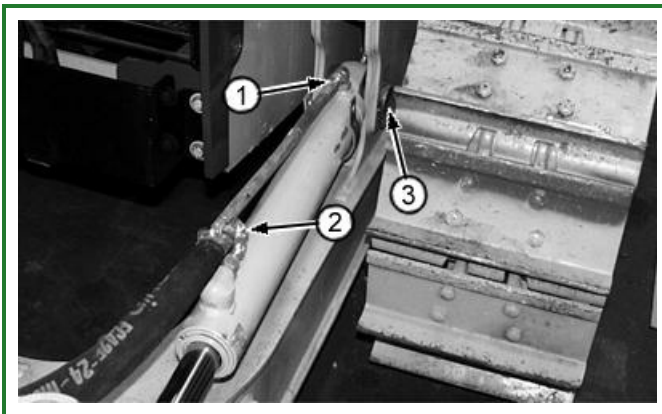

T119486B-UN: Angle Cylinder

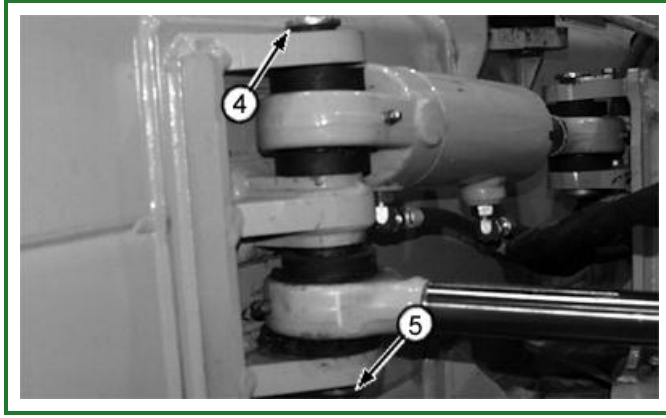

T119487B-UN: Angle Cylinder Pin

LEGEND:

- 1 - Angle Cylinder Head End Hose
- 2 - Angle Cylinder Rod End Hose
- 3 - Angle Cylinder Head End Pin
- 4 - Tilt Cylinder Head End Pin
- 5 - Angle Rod End Pin

Tag and disconnect cylinder hoses (1 and 2) and grease lines. Cap and plug all openings.

4. Attach cylinder to hoist using lift strap.
5. Remove cap screw, retainer, and pin (3). Remove cap screws and retainers on tilt cylinder head end and angle cylinder rod end. Drive tilt cylinder head end pin (4) and angle rod end pin (5) out.
6. Remove angle cylinder.
7. Inspect rubber bushings. Replace if necessary. [See Angle, Lift, and Tilt Cylinders Disassemble and Assemble \(John Deere 120 Series Cylinders\)](#) . (Group 3260.)
8. Install cylinder and pins. Connect hoses and grease lines.

Go to [Section_32:Group_3260](#)

CED,TX03768,2530-19-20090205

Lift Cylinder Remove and Install

1. Lower all equipment to the ground.
2. Stop engine. Operate all hydraulic controls to relieve system pressure.

3.

⚠ CAUTION:

To avoid injury from escaping fluid under pressure, stop engine and relieve the pressure in the system before disconnecting or connecting hydraulic or other lines. Tighten all connections before applying pressure.



X9811-UN: Fluid Symbol

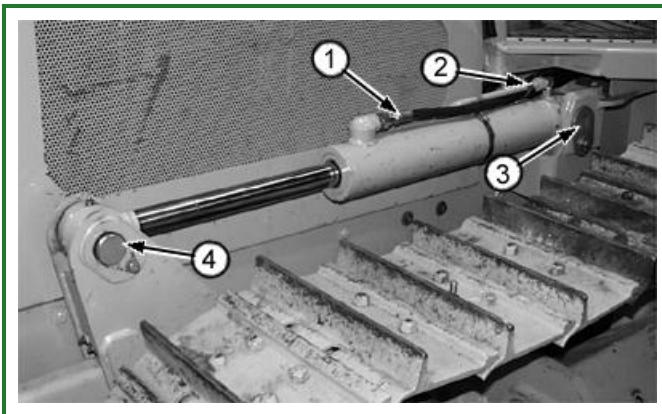

T119485B-UN: Lift Cylinder

LEGEND:

- 1 - Cylinder Rod End Hose
- 2 - Cylinder Head End Line
- 3 - Head End Pin
- 4 - Rod End Pin

Tag and disconnect cylinder rod end hose (1) and cylinder head end line (2). Cap and plug all openings.

4. Attach cylinder to hoist using lift strap.
5. Remove cap screws and retainers. Remove pins (3 and 4).

6. Remove lift cylinder. See [Angle, Lift, and Tilt Cylinders Disassemble and Assemble \(John Deere 120 Series Cylinders\)](#) . (Group 3260.)
7. Install cylinder and pins. Connect cylinder rod end hose (1) and cylinder head end line (2).

Go to [Section_32:Group_3260](#)

CED,OUTX547,207-19-20090205

Angle, Lift, and Tilt Cylinders Disassemble and Assemble (John Deere 120 Series Cylinders)

For repair information on 120 Series Hydraulic Cylinders [see Cylinder Identification](#) . (CTM120519.)

Go to [Section_32:Group_3260](#)

RG80575,0000007-19-20150729

Section 9900: Dealer Fabricated Tools

Group 0999: Dealer Fabricated Tools

DF1041 Track Nut Removal Tool

DF1063 Final Drive Lift Bracket

DFT1087 Track Recoil Spring Disassembly and Assembly Guard Tool

DFT1119 Pump Support

DFT1130 Adapter

DFT1132 Hydrostatic Motor Removal and Installation Tool

DFT1137 Hydrostatic Motor Removal and Installation Tool

DFT1165 Left Hand Hydrostatic Motor Lifting Bracket

DFT1166 Final Drive Lifting Bracket Adapter

DFT1167 Final Drive Lifting Bracket Adapter Spacer

DFT1168 Right Hand Hydrostatic Motor Lifting Bracket

DFT1211 Final Drive Lifting Bracket Adapter

DFRW20 Compressor Holding Fixture

ST4920 Track Recoil Spring Disassembly and Assembly Tool

DF1041 Track Nut Removal Tool

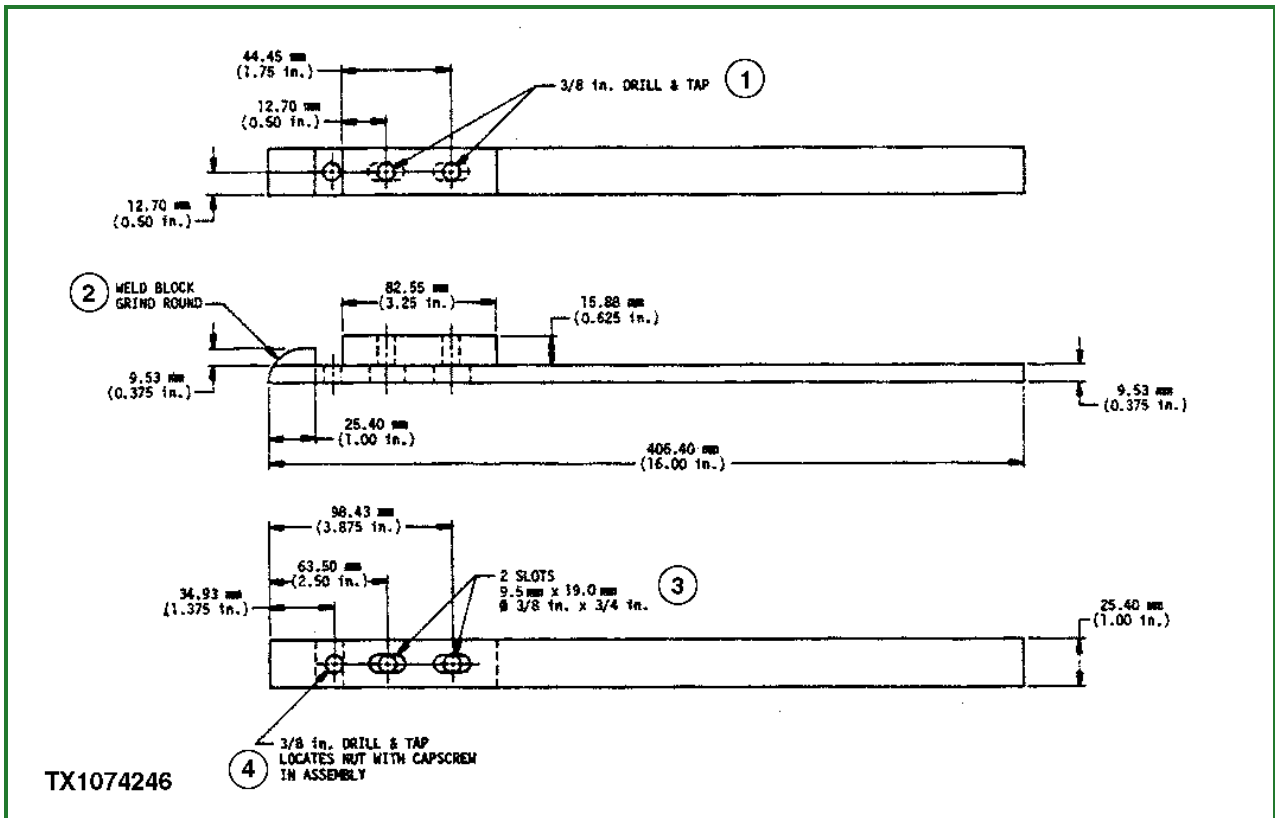

TX1074246-UN: DF1041 Track Nut Removal Tool

LEGEND:

- 1 - 3/8 in. Drill and Tap
- 2 - Weld Block; Grind Round
- 3 - 2 Slots 9.5 mm x 19.0 mm (3/8 in. x 3.4 in.)
- 4 - 3/8 in. Drill and Tap; Locates Nut with Cap Screw in Assembly

Tool can be made in dealer's shop. Used to remove and install track shoe nuts.

Material: 1020 Flat Stock

Go to Section_9900:Group_0999

9900,WW11-19-20100322

DF1041 Track Nut Removal Tool

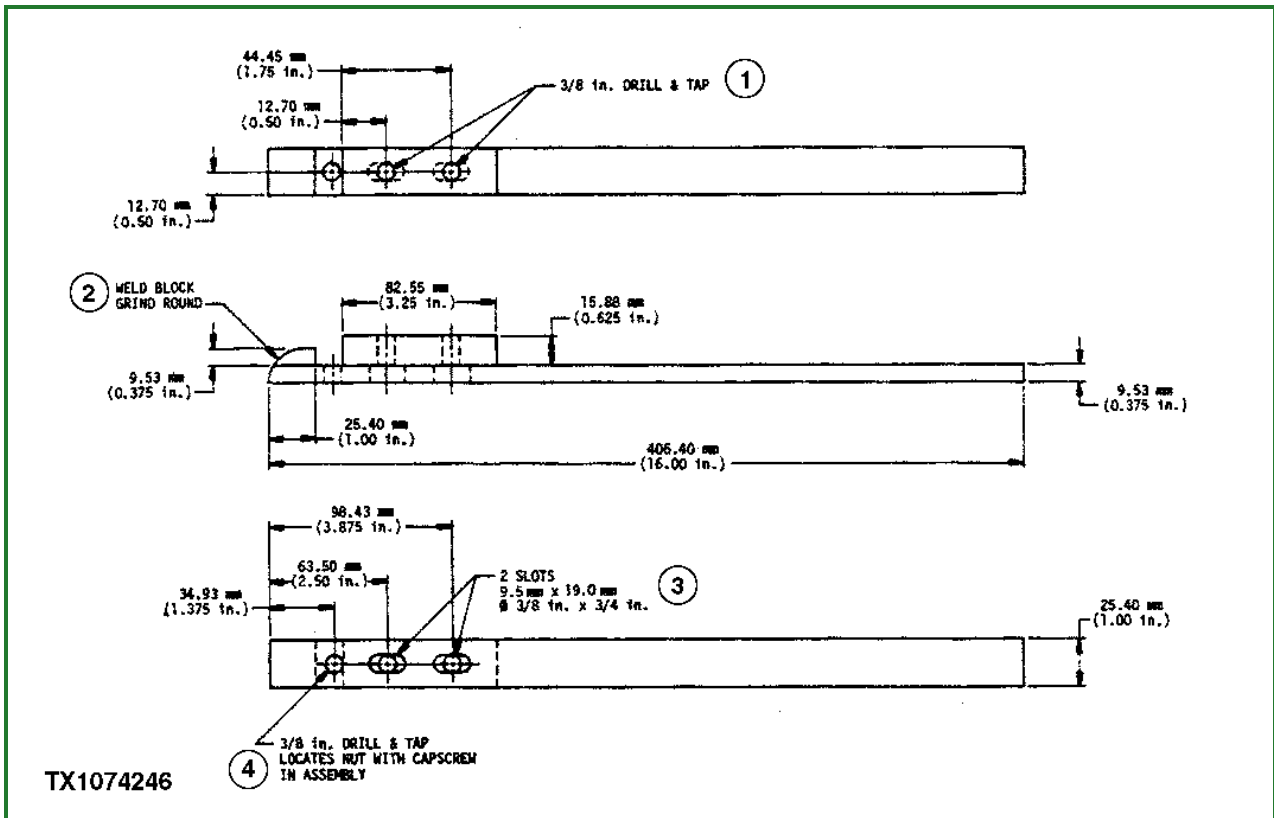

TX1074246-UN: DF1041 Track Nut Removal Tool

LEGEND:

- 1 - 3/8 in. Drill and Tap
- 2 - Weld Block; Grind Round
- 3 - 2 Slots 9.5 mm x 19.0 mm (3/8 in. x 3.4 in.)
- 4 - 3/8 in. Drill and Tap; Locates Nut with Cap Screw in Assembly

Tool can be made in dealer's shop. Used to remove and install track shoe nuts.

Material: 1020 Flat Stock

Go to Section_9900:Group_0999

9900,WW11-19-20100322

DF1063 Final Drive Lift Bracket

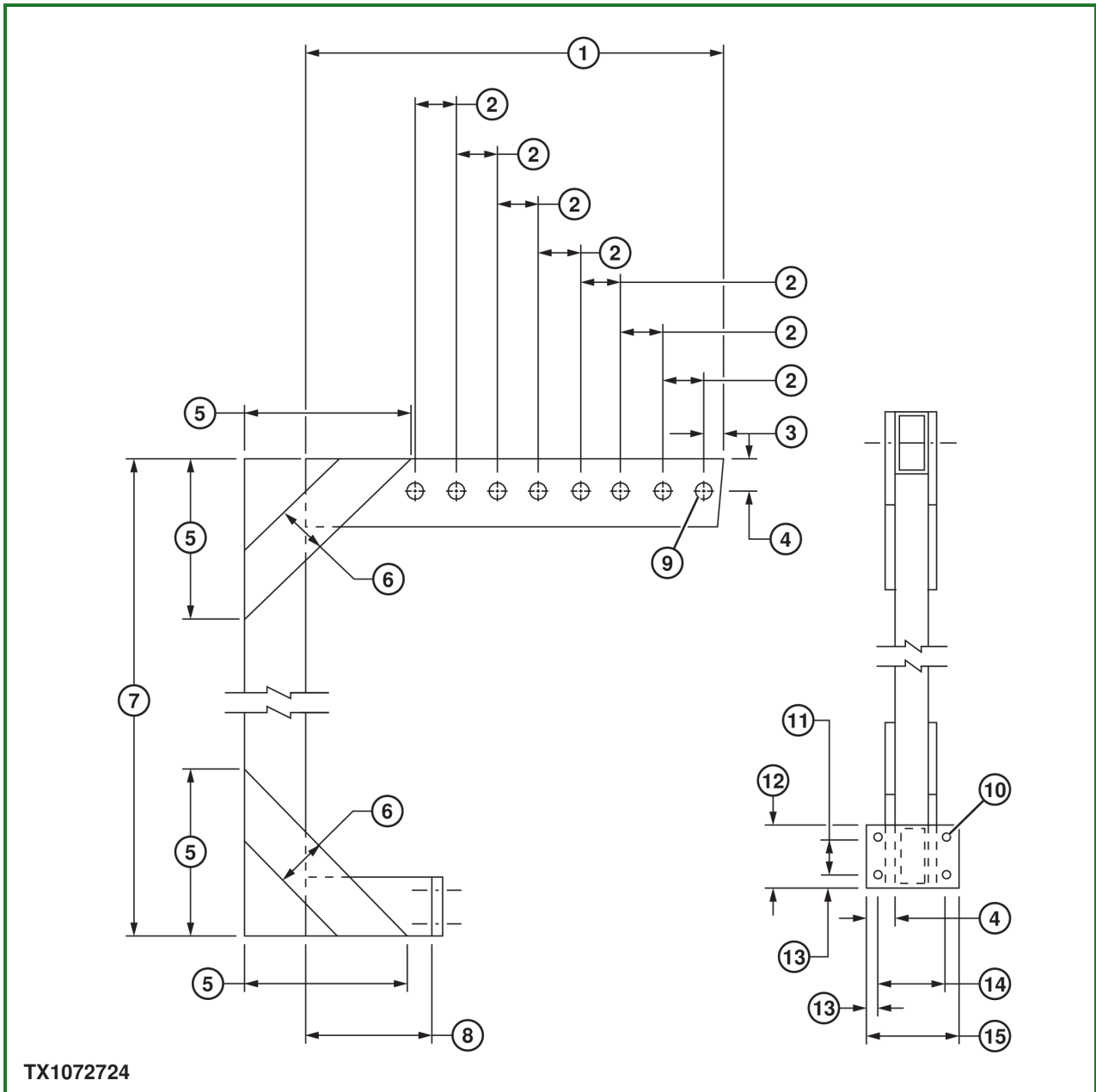

TX1072724-UN: DF1063 Final Drive Lift Bracket

LEGEND:

- 1 - 508 mm (20.0 in.)
- 2 - 50.8 mm (2.00 in.)
- 3 - 25.4 mm (1.00 in.)
- 4 - 38.1 mm (1.50 in.)
- 5 - 203.2 mm (8.00 in.)
- 6 - 63.5 mm (2.50 in.)
- 7 - 2286 mm (90.00 in.)
- 8 - 152.4 mm (6.00 in.)
- 9 - 3/4 in. Drill Through Both Sides (8 holes)
- 10 - 3/8 in. Drill Through (4 holes)
- 11 - 44.5 mm (1.75 in.)
- 12 - 76.2 mm (3.00 in.)
- 13 - 15.9 mm (0.625 in.)
- 14 - 82.6 mm (3.25 in.)

15 - 114.3 mm (4.50 in.)

Tool used to remove and install final drives.

Material required:

- 1.5 in. x 3.0 in. Square Tube
- 1/2 in. 1020 Steel
- 3/8 in. x 1.5 in. Cap Screw with Nut (4 used)

Go to [Section_9900:Group_0999](#)

CED,TX03399,5076-19-19981124

DFT1087 Track Recoil Spring Disassembly and Assembly Guard Tool

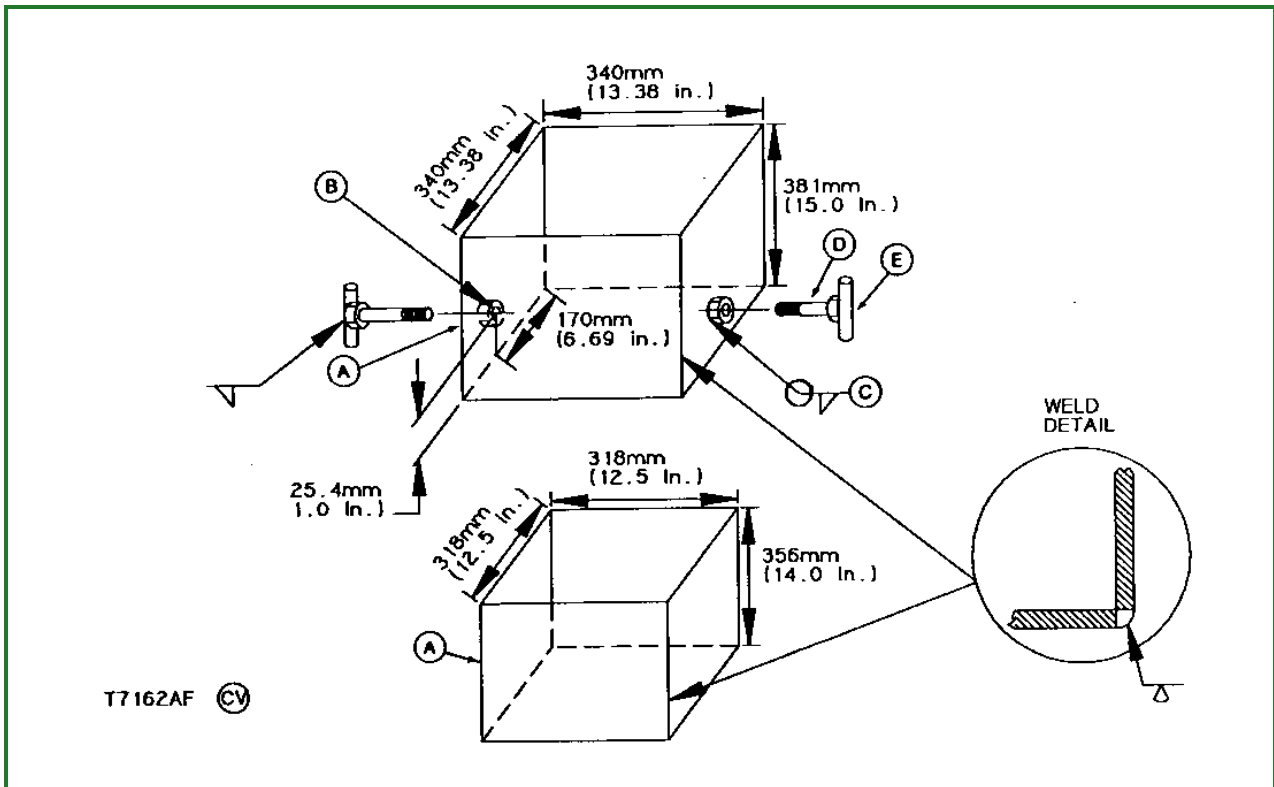
**T7162AF-UN: Track Recoil Spring Guard Tool****LEGEND:**

- A - 3/16 in. 1020 CR Steel Plate
- B - 9/16 in. Hole (2 places)
- C - 1/2 in. Nut (2 used)
- D - 1/2 x 2 in. Cap Screw (2 used)
- E - 1/2 x 3 in. Steel Round Stock (2 used)

Track Disassembly and Assembly Guard Tool is used with ST4920 Track Recoil Spring Disassembly and Assembly Tool.

Material required:

- 3/16 in. 1020 CR Steel Plate (A)
- 1/2 in. Nut (C) (2 used)
- 1/2 x 2 in. Cap Screw (D) (2 used)
- 1/2 x 3 in. Steel Round Stock (E) (2 used)

Go to [Section_9900:Group_0999](#)

TX,01,RB432-19-20060419

DFT1119 Pump Support

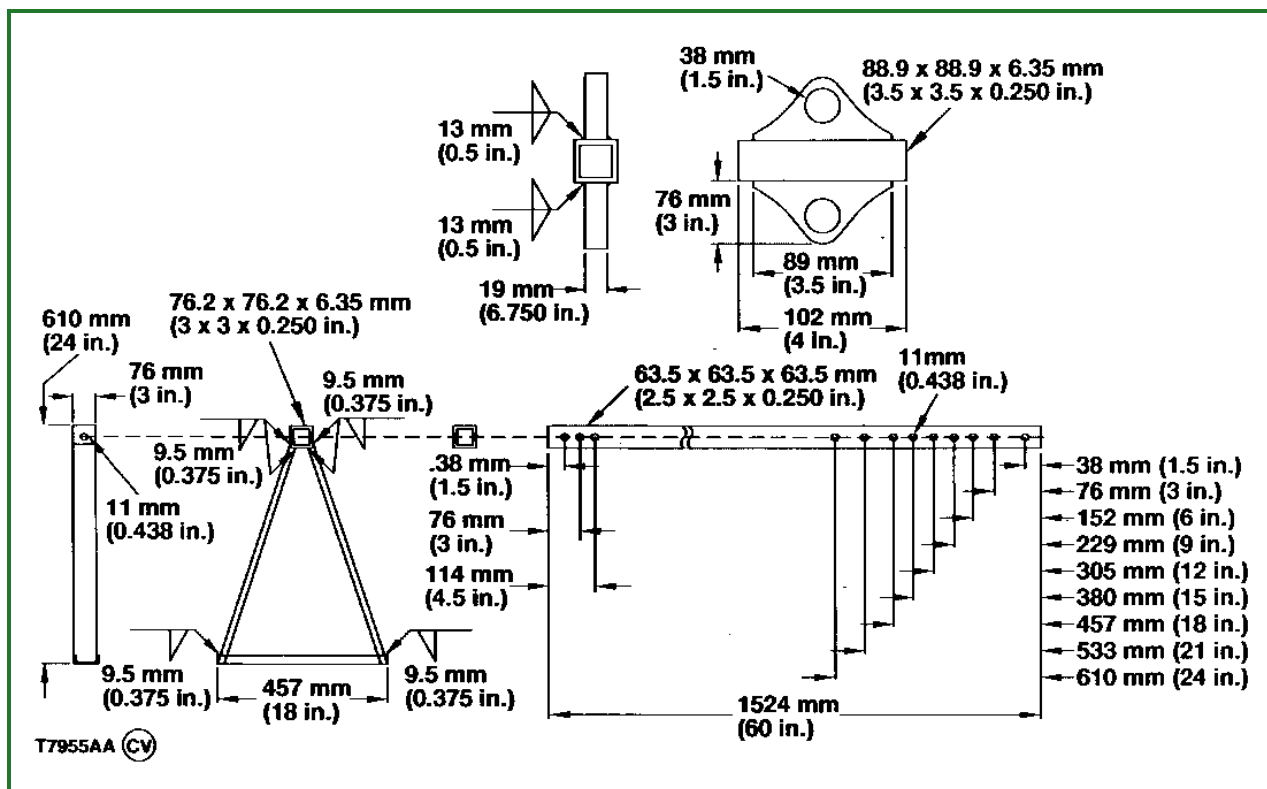

T7955AA-UN: Pump Support

Pump support is used with a small winch hoist to support the hydrostatic pumps when an engine is removed.

Two end stands are needed.

Drill the holes through the square steel tubing so they are centered.

Material required:

- C3 x 5 Steel Channel
- 88.9 x 88.9 x 6.35 mm (3.5 x 3.5 x 0.250 in.) Square Steel Tubing
- 76.2 x 76.2 x 6.35 mm (3 x 3 x 0.250 in.) Square Steel Tubing
- 63.5 x 63.5 x 6.35 mm (2.5 x 2.5 x 0.250 in.) Square Steel Tubing
- 19 mm (3/4 in.) flat bar stock
- M10 x 89 mm or 3/8 x 3 1/2 in. D Grade (SAE Grade 5) Cap Screw (2 used)
- M10 or 3/8 in. D Grade (SAE Grade 5) Nut (2 used)

Go to [Section_9900:Group_0999](#)

CED, TX03399, 2297-19-20060419

DFT1130 Adapter

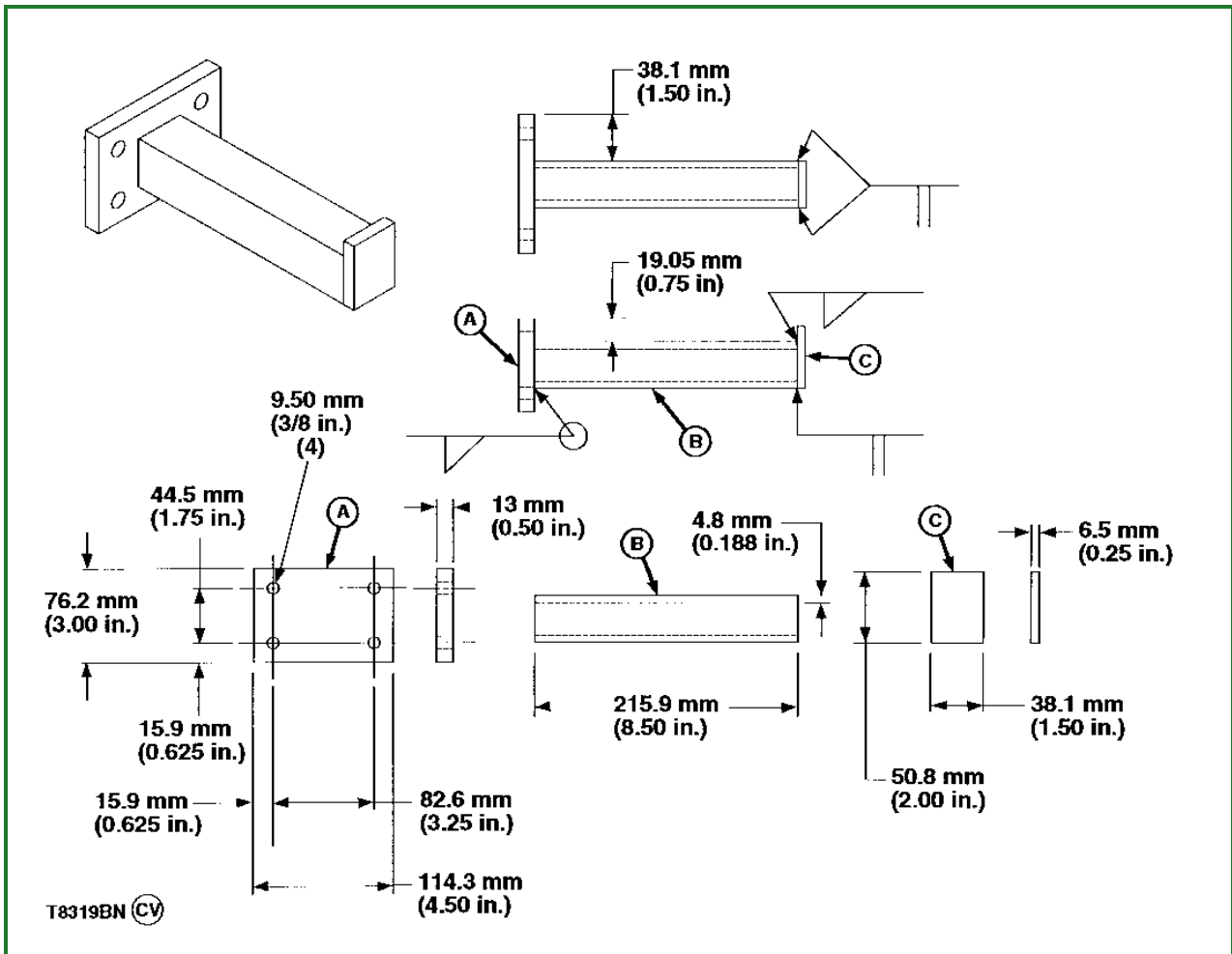

T8319BN-UN: Adapter

LEGEND:

A - Adapter Plate

B - Tube

C - Stop Plate

Adapter is used with DFT1063 Pump Lifting Bracket to remove and install hydrostatic pumps.

Material required:

- 1/2 in. 1020 Steel Plate (A)
- 1-1/2 in. x 1-1/2 in. x 3/16 in. Square Tube (B)
- 1/4 in. 1020 Steel Plate (C)

Go to [Section_9900:Group_0999](#)

TX,9900,YY1199-19-19990413

DFT1132 Hydrostatic Motor Removal and Installation Tool

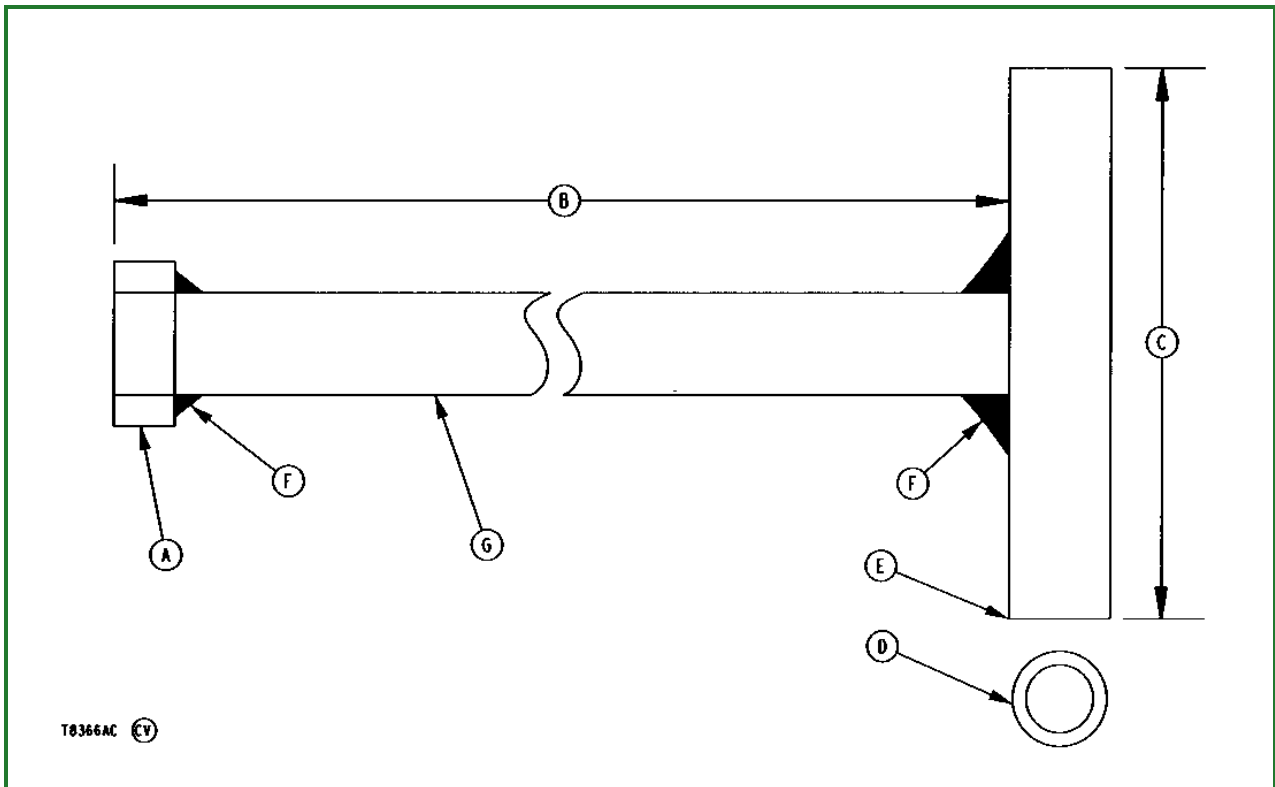
**T8366AC-UN: Bracket****LEGEND:**

A - 1 in. Nut

B - Pipe 2134 mm (7 ft) Long

C - Pipe 457 mm (18 in.) Long

D - 1 in. ID Heavy Wall Steel Pipe

E - Pipe

F - Weld

G - Pipe

This tool is used to remove and install hydrostatic motors from rear of machine.

Material required:

- 1 in. piece heavy wall steel pipe 8 ft. x 6 in. long
- Weld (E) to (G)

Go to [Section_9900:Group_0999](#)

CED, TX03399, 5070-19-20091201

DFT1137 Hydrostatic Motor Removal and Installation Tool

IMPORTANT:

Modification to tool as shown must be made for right side motor removal.

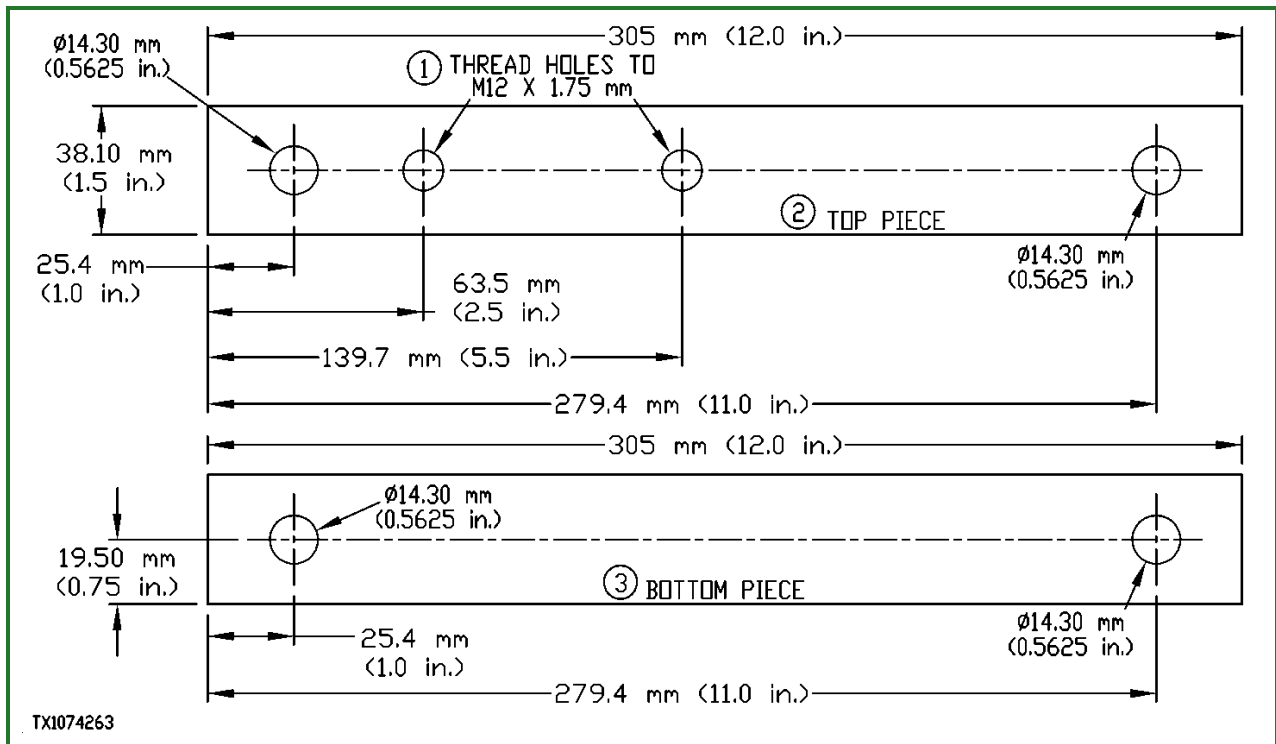

TX1074263-UN: DFT1137 Hydrostatic Motor Removal and Installation Tool

LEGEND:

- 1 - Thread Holes to M12 x 1.75 mm
- 2 - Top Piece
- 3 - Bottom Piece

This tool will need to be modified with second threaded hole to allow right side hydrostatic motor to attain correct index position. This tool is to be used with DFT1132 to remove and install hydrostatic motors from rear access hole in frame.

Material required:

- 1-1/2 in. x 3/4 in. x 12 in. long steel bars (2 used)
- M12 x 1.75 eyebolt
- 1/2 in. x 9 in. cap screws with nuts and washers

Install and tighten eyebolt in bracket. Trim any excess eyebolt material so it is even with bottom surface of bracket.

Go to [Section_9900:Group_0999](#)

CED,OUO1065,1021-19-20100322

DFT1165 Left Hand Hydrostatic Motor Lifting Bracket

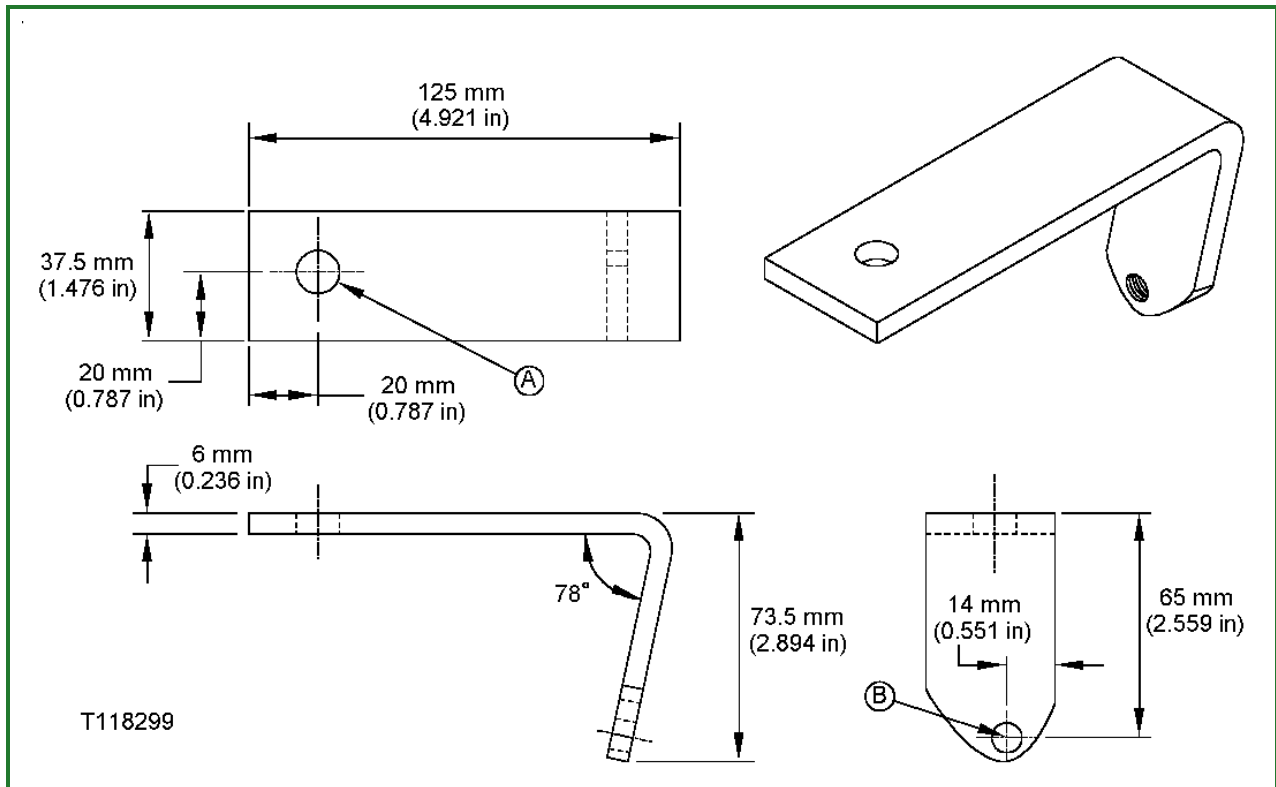
**T118299-UN: L.H. Hydrostatic Motor Lifting Bracket****LEGEND:**

A - 12 mm (0.472 in.) hole

B - M10 x 1.5 drill and tap hole

Used with DFT1132 Hydrostatic Motor Removal and Installation Tool to remove and install hydrostatic left hand motor.

Material: 1020 Flat Stock 7-7/8 in. long, 1/4 x 1-1/2 in.

Go to [Section_9900:Group_0999](#)

CED, TX03399,5068-19-19990413

DFT1166 Final Drive Lifting Bracket Adapter

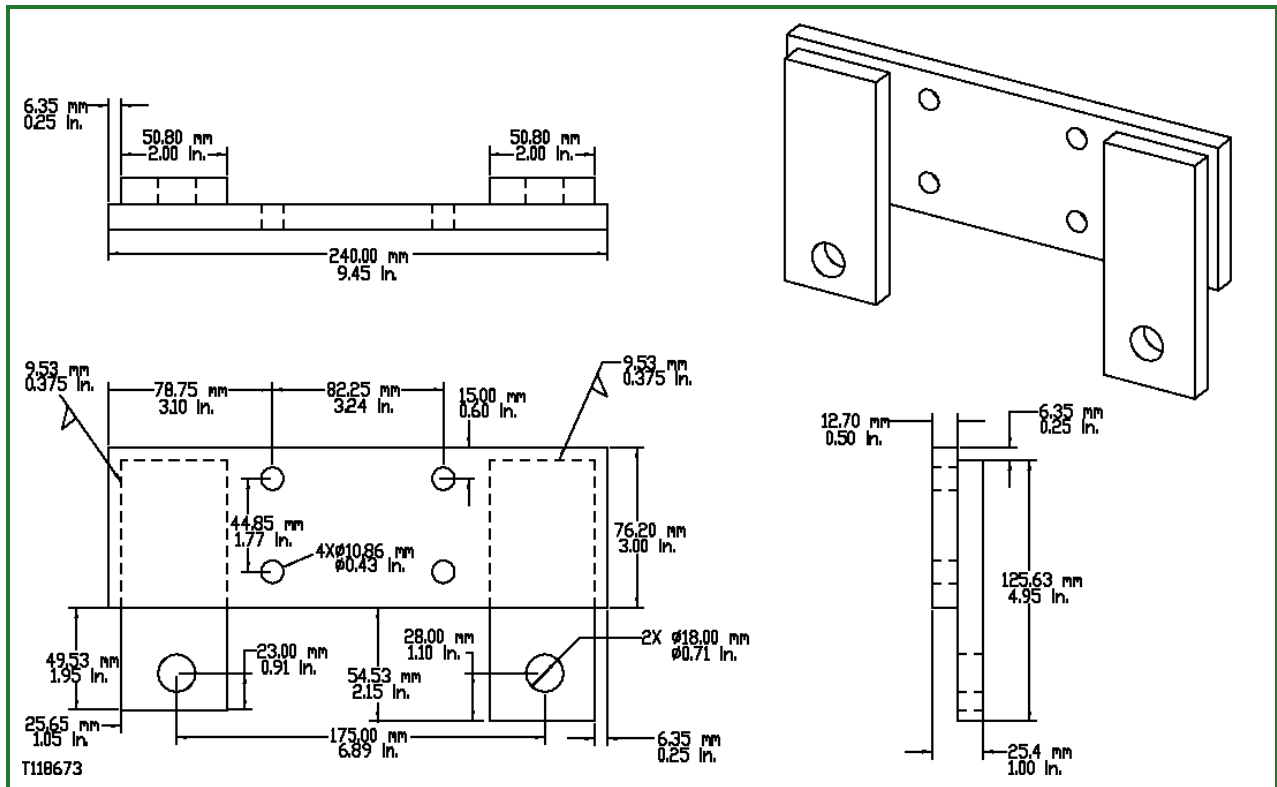

T118673-UN: Final Drive Lifting Bracket Adapter

To be used with DFT1063 Final Drive Lifting Bracket and DFT1167 Final Drive Lifting Bracket Adapter Spacer.

Material: 1/2 in. 1020 Steel

Go to [Section_9900:Group_0999](#)

CED, TX03399, 5084-19-19981130

DFT1167 Final Drive Lifting Bracket Adapter Spacer

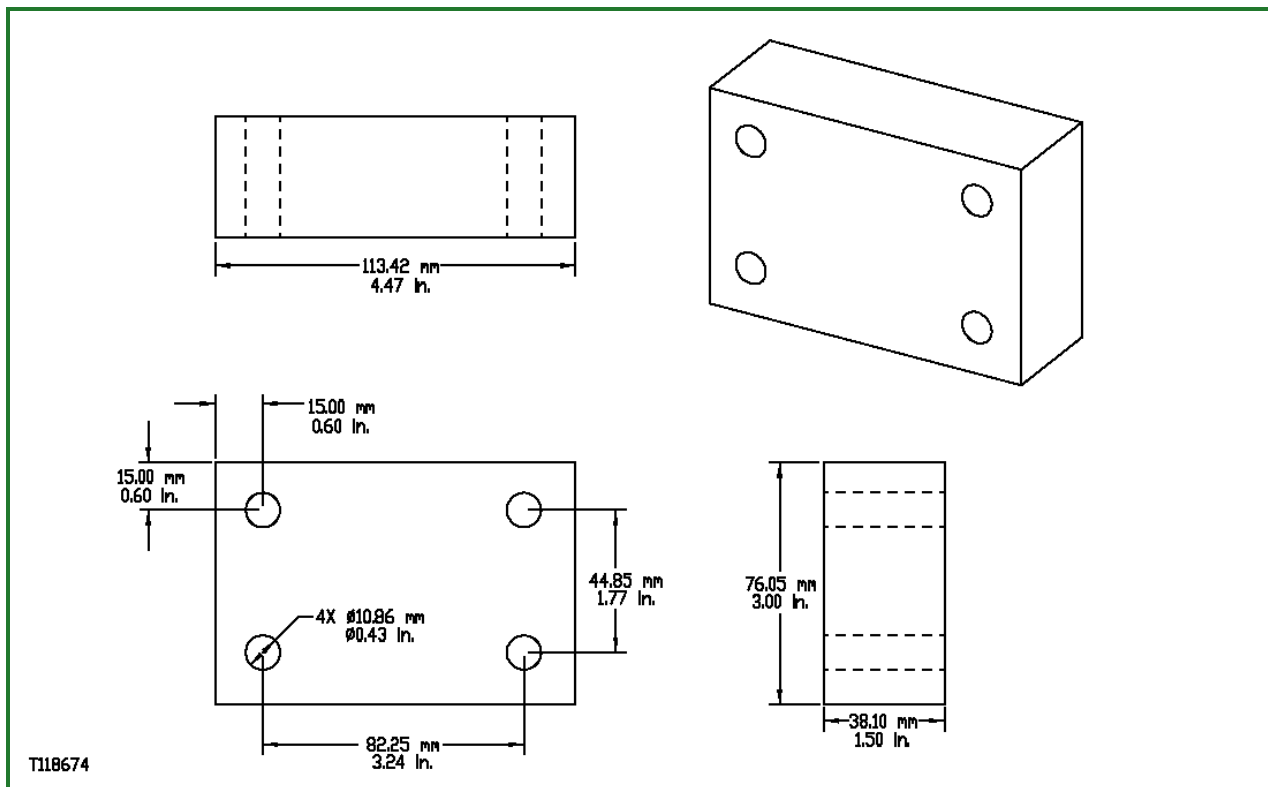

T118674-UN: Final Drive Lifting Bracket Adapter Spacer

To be used with DFT1166 Final Drive Lifting Bracket Adapter when installing DFT1063 Final Drive lifting Bracket.

Material: 1/2 in. 1020 Steel Plate

Go to [Section_9900:Group_0999](#)

CED, TX03399, 5085-19-20060419

DFT1168 Right Hand Hydrostatic Motor Lifting Bracket

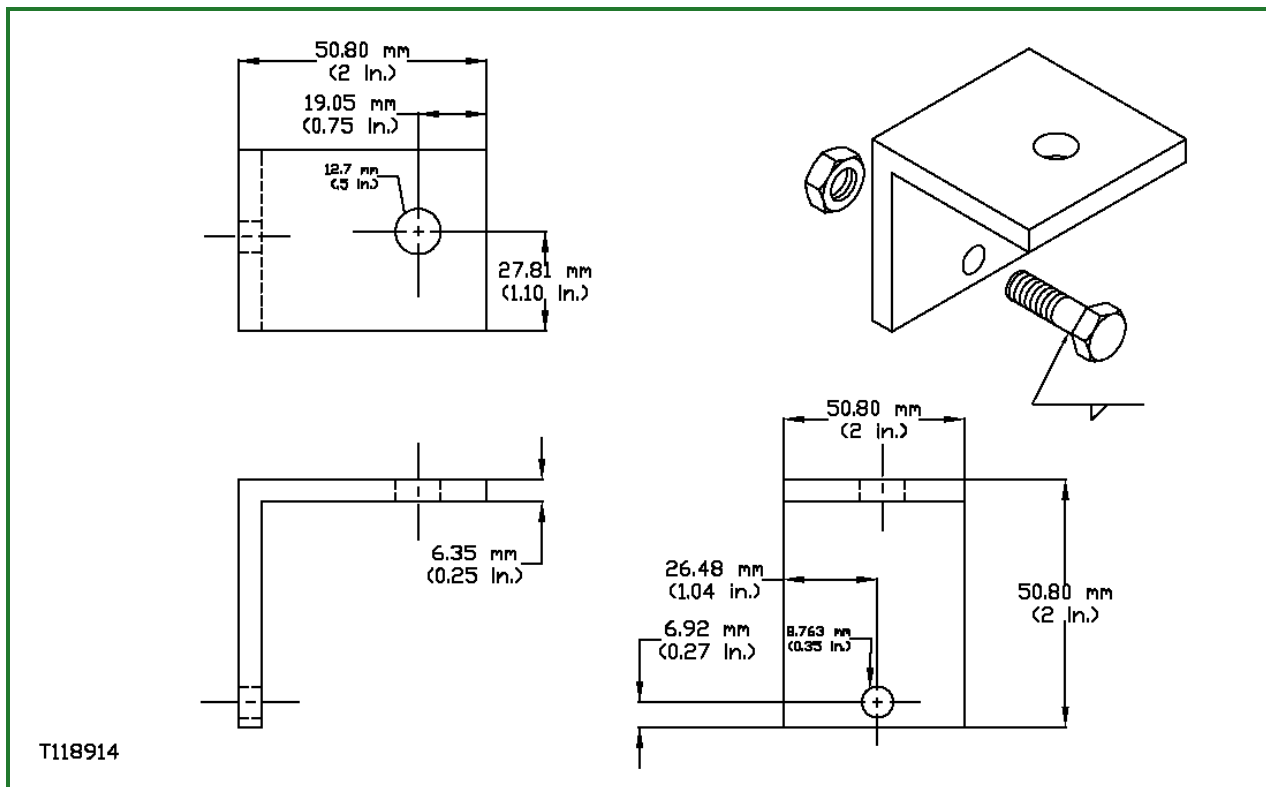

T118914-UN: R.H. Hydrostatic Motor Lifting Bracket

LEGEND:

- A - 12 mm (0.472 in.) hole
 B - M10 x 1.5 drill and tap hole

Used with DFT1132 Hydrostatic Motor Removal and Installation Tool to remove and install hydrostatic right hand motor (without winch option).

Material required:

- 2 in. x 2 in. x 1/4 in. angle iron
- 5/16 x 1-1/2 in. cap screw

Cap screw must be welded to angle iron.

Go to [Section_9900:Group_0999](#)

CED,OUO1008,160-19-19990413

DFT1211 Final Drive Lifting Bracket Adapter

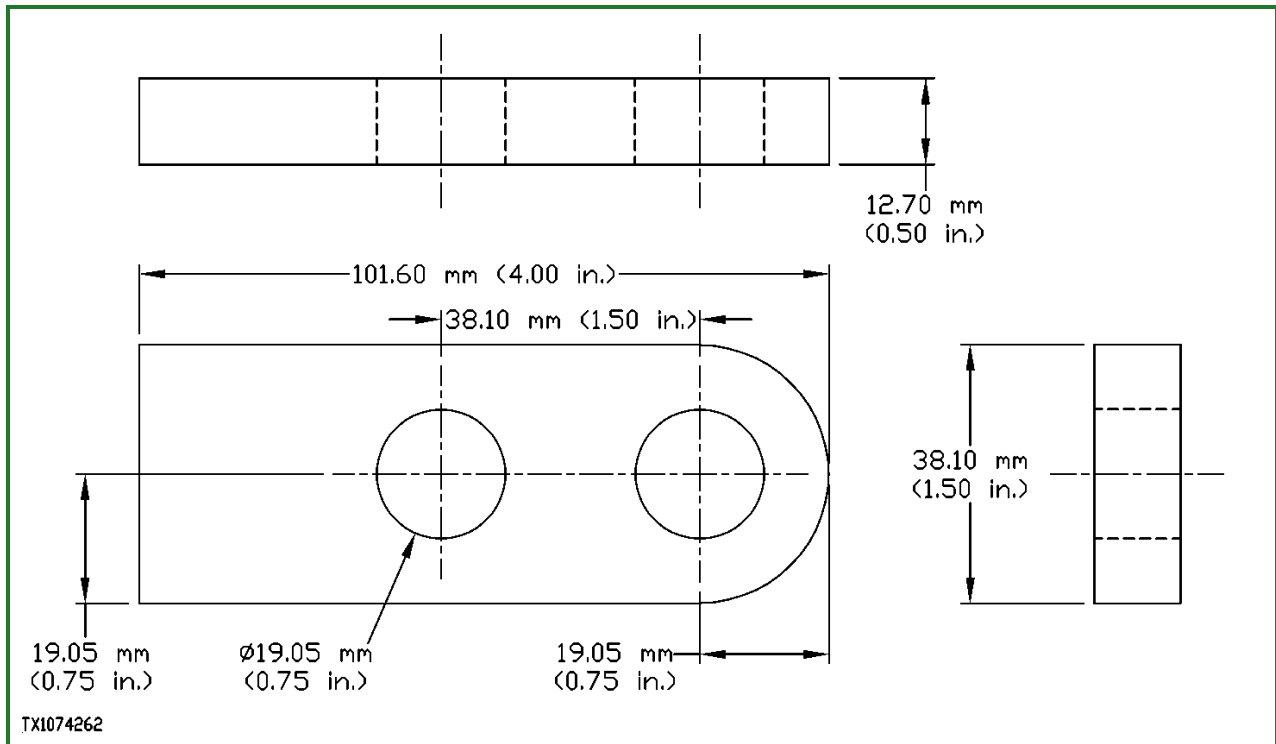
**TX1074262-UN: Lifting Bracket Adapter**

Adapter used with JT01748 Lifting Bracket to remove and install final drive.

Material required:

- 1/2 in. 1020 steel plate 1.5 x 4 in.

Go to [Section_9900:Group_0999](#)

CED,OUO1065,1020-19-20100322

DFRW20 Compressor Holding Fixture

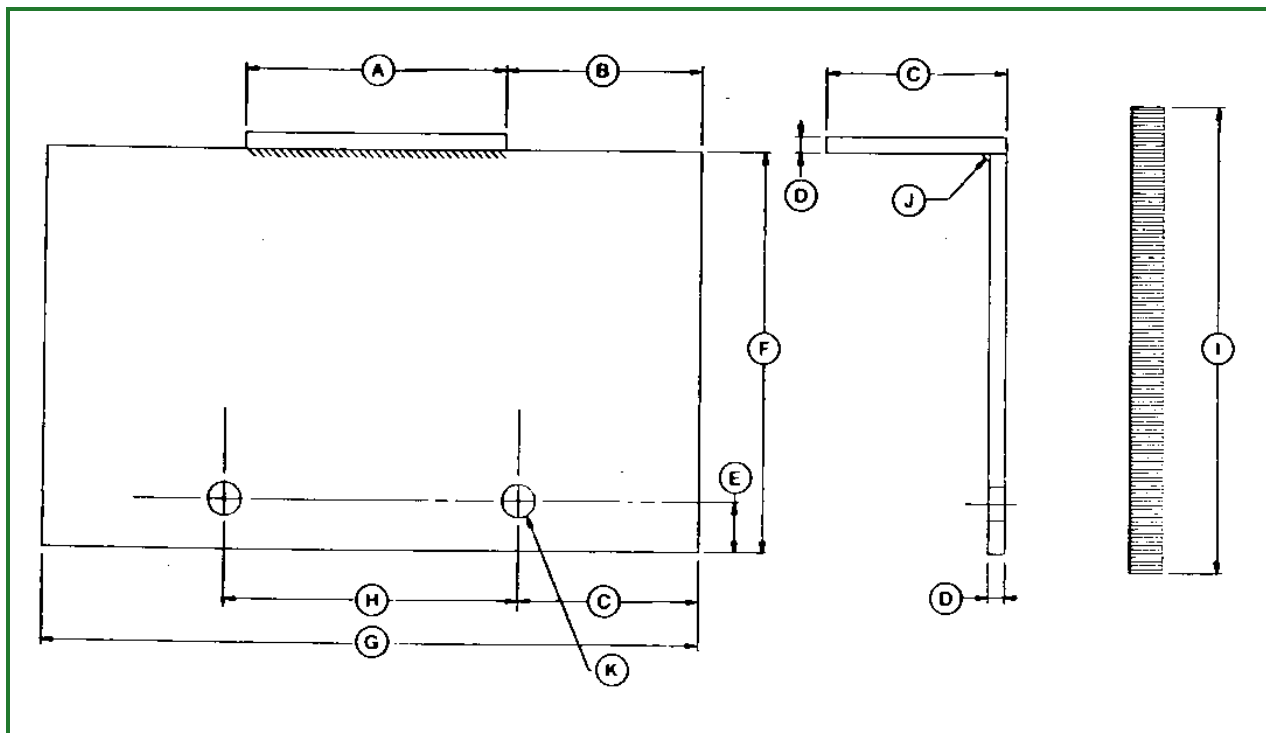

RW13619-UN: Cross Section of DFRW20 Holding Fixture

LEGEND:

- A - 102 mm (4 in.)
- B - 76 mm (3 in.)
- C - 70 mm (2.75 in.)
- D - 6.4 mm (0.25 in.)
- E - 19 mm (0.75 in.)
- F - 152 mm (6 in.)
- G - 254 mm (10 in.)
- H - 114 mm (4.5 in.)
- I - 178 mm (7 in.)
- J - Fillet Weld
- K - Two Holes

Material required:

- 2—Steel Plates (4 x 2.75 in.) and (10 x 6 in.)
- 2—Threaded Steel Rods (0.5 x 7 in.)
- 4—Matching Lock Washers and Nuts

Tool is used to hold air conditioning compressor during assembly and disassembly.

Go to [Section_9900:Group_0999](#)

TX,18,RB766-19-20060419

ST4920 Track Recoil Spring Disassembly and Assembly Tool

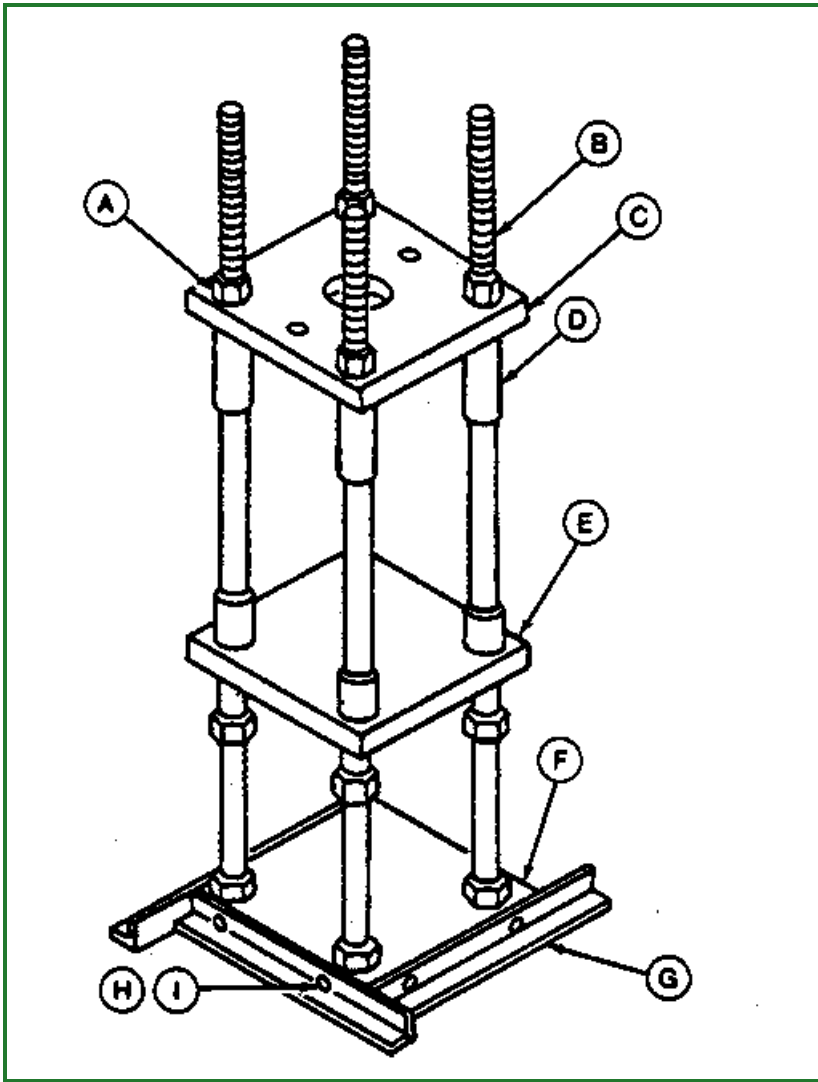
**T6585UY-UN: Track Recoil Spring Tool****LEGEND:**

- A - Nut (12 used)
- B - Stud (4 used)
- C - Holder
- D - Eyebolt (2 used)
- E - Supporting Plate
- F - Base Plate
- G - Base (4 used)
- H - Cap Screw (8 used)
- I - Lock Washer (8 used)

NOTE:

It is recommended that DFT1087 Track Recoil Spring Disassembly and Assembly Guard Tool be used with track recoil spring disassembly and assembly tool.

Dimensions given are metric.

Tool is the same as used on other machines except the holder (C). For each track adjuster use the holder with the correct size hole for the nut on that track adjuster.

Track Recoil Spring Disassembly and Assembly Tool (compression tool) is used with hydraulic jack to compress recoil spring in track adjuster repair.

Material required:

- 1020 HR Steel for Holder (C), Supporting Plate (E), Base Plate (F), and Base (G).
- "D" Grade (SAE Grade 5) for Eyebolts (D), Nuts (A), and Cap Screws (H).
- "F" Grade (SAE Grade 8) for Studs (B).

Print Numbers:

- A—ST4050 Nut
- B—ST4045 Bolt
- C—ST4035 Holder (Plate)
 - ST4036 Holder (Plate)
 - ST4037 Holder (Plate)
- D—ST4047 Eyebolt
- E—ST4040 Supporting Base
- F—ST4042 Base Plate
- G—ST4041 Base
- H—ST4046 Cap Screw
- I—ST4049 Lock Washer

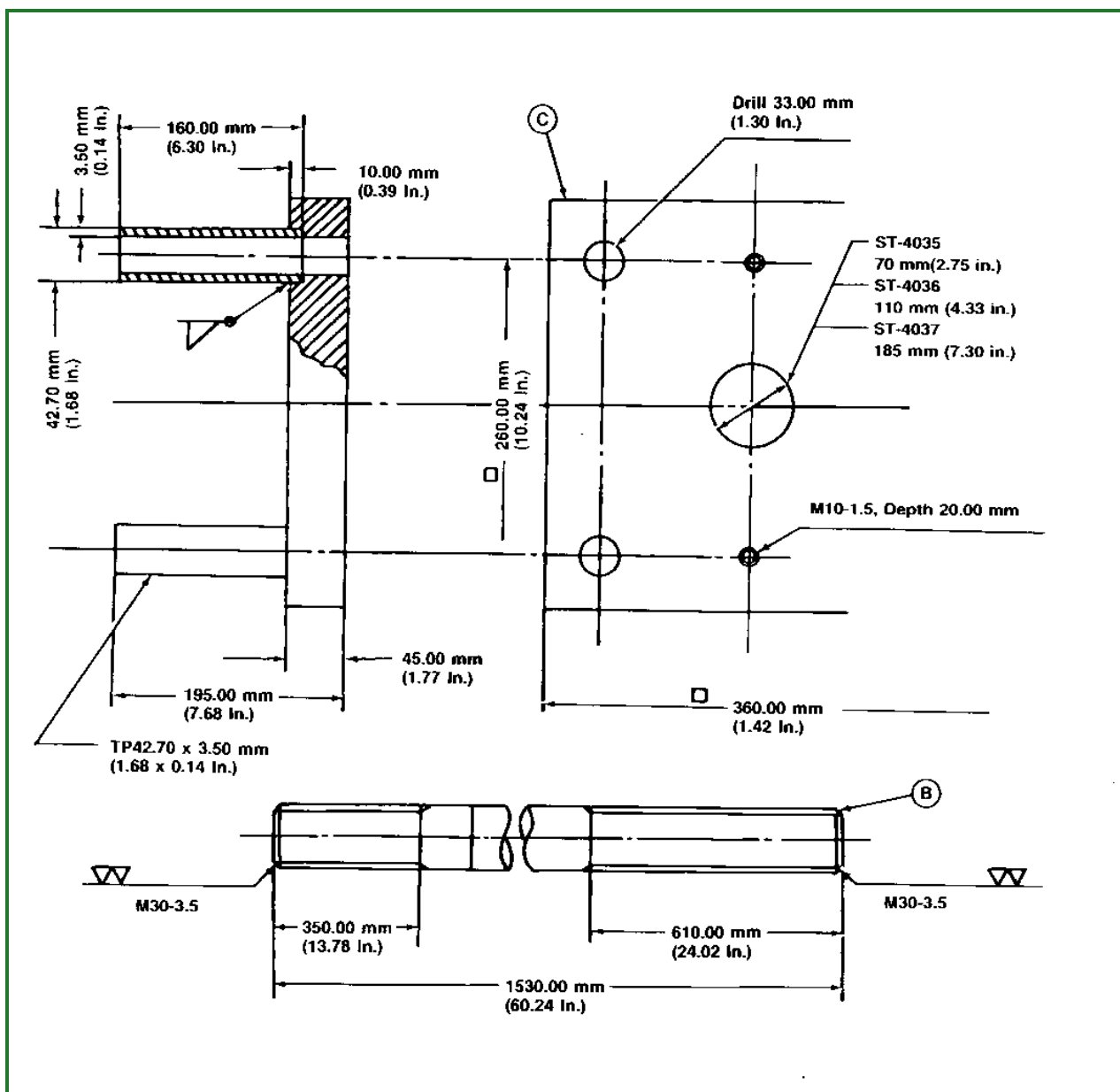

T7029CI-UN: Track Recoil Spring Tool

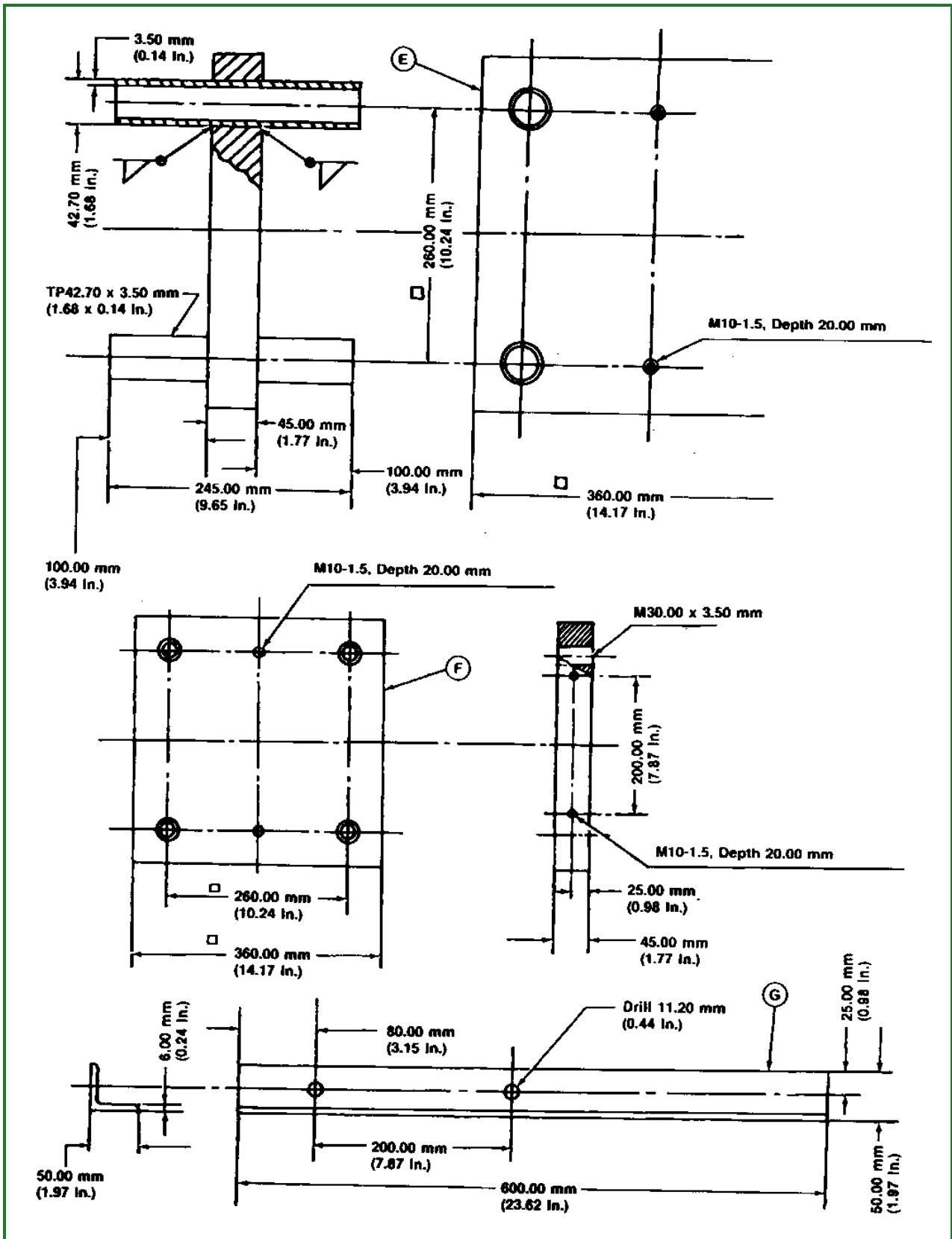

T7029CH-UN: Track Recoil Spring Tool

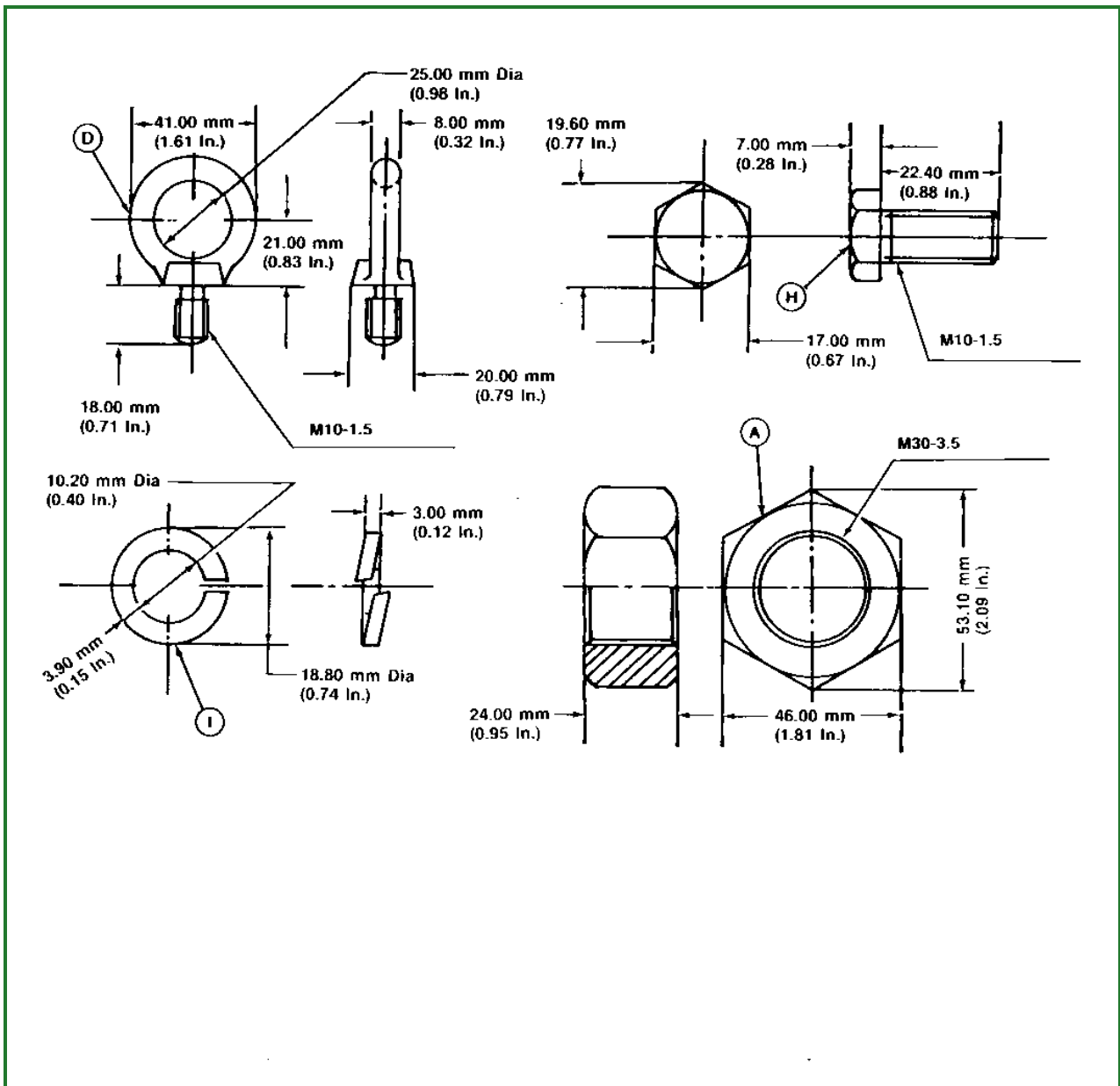

T7029CG-UN: Track Recoil Spring Tool

LEGEND:

- A - Nut (12 used)
- B - Stud (4 used)
- C - Holder
- D - Eyebolt (2 used)
- E - Supporting Plate
- F - Base Plate
- G - Base (4 used)
- H - Cap Screw (8 used)
- I - Lock Washer (8 used)

Go to [Section_9900:Group_0999](#)

TX,01,RB519-19-20060419

tm2258 - 450J, 550J, 650J Crawler Dozer (S.N. —141666) Technical Manual

MAIN SECTIONNS

Foreword

HELP!! HELP!! HELP!! HELP!!

General Information

Safety

Torque Values

Tracks

Track System

Axles and Suspension Systems

Drive Axle Housing and Support

Axle Shaft, Bearings, and Reduction Gear

Transmission

Removal and Installation

Controls Linkage

Hydrostatic System

Engine

Removal and Installation

Engine Auxiliary Systems

Cold Weather Starting Aids

Radiator and Fan Shroud

Engine Speed Control

Intake System

External Exhaust System

Mounting Frame

External Fuel Supply System

Dampener Drive

Elements

Park Brake

Removal and Installation

Control Linkage

Hydraulic System

Operator's Station

Removal and Installation

Operator's Enclosure

Seat and Seat Belt

Heating and Air Conditioning

Sheet Metal and Styling

Hood and Engine Enclosure

Grille and Grille Housing

Main Hydraulic System

Hydraulic System

Bulldozer

Blades

Control Linkage

Frames

Hydraulic System

Dealer Fabricated Tools

Dealer Fabricated Tools