

# 450J, 550J, 650J Crawler Dozer Repair

(Serial No. - 141666)

## TECHNICAL MANUAL

### 450J, 550J, 650J Crawler Dozer Repair (S.N. —141666)

TM2258 29APR10 (ENGLISH)

For complete service information also see:

450J, 550J and 650J Crawler Dozer Operation and Test (S.N. —141666) .....	TM2257
450J, 550J and 650J Crawler Dozer Operator's Manual .....	OMT204685
Alternators and Starting Motors .....	CTM77
POWERTECH® 4.5L & 6.8L Diesel Engines Base Engine .....	CTM104
4000S Winches .....	CTM166
Super Caddy Oil Cleanup Procedure.....	CTM310
POWERTECH®4.5L & 6.8L Diesel Engines Level 12 Electronic Fuel System With Stanadyne DE10 Pump .....	CTM331
120 Series Hydraulic Cylinders .....	TM-H120A
Undercarriage Appraisal Manual .....	SP326
SERVICE ADVISOR™ System Computer Connection.....	T133991

**Worldwide Construction  
And Forestry Division**

LITHO IN U.S.A.

# Introduction

## Foreword

This manual is written for an experienced technician. Essential tools required in performing certain service work are identified in this manual and are recommended for use.

Live with safety: Read the safety messages in the introduction of this manual and the cautions presented throughout the text of the manual.



This is the safety-alert symbol. When you see this symbol on the machine or in this manual, be alert to the potential for personal injury.

Technical manuals are divided in two parts: repair and operation and tests. Repair sections tell how to repair the components. Operation and tests sections help you identify the majority of routine failures quickly.

Information is organized in groups for the various components requiring service instruction. At the beginning of each group are summary listings of all applicable essential tools, service equipment and tools, other materials needed to do the job, service parts kits, specifications, wear tolerances, and torque values.

Technical Manuals are concise guides for specific machines. They are on-the-job guides containing only the vital information needed for diagnosis, analysis, testing, and repair.

Fundamental service information is available from other sources covering basic theory of operation, fundamentals of troubleshooting, general maintenance, and basic type of failures and their causes.

TE14778,000003E -19-19MAY04-1/1

Introduction

**HELP!! HELP!! HELP!! HELP!!**

We need your help to continually improve our technical publications. Please FAX or mail your comments, ideas and improvements.

**SEND TO:** John Deere Dubuque Works  
P.O. Box 538  
Attn: Publications Supervisor, Dept. 303  
Dubuque, Iowa 52004-0538

**FAX NUMBER: 319-589-5800**

Ideas, Comments (Please State Page Number): \_\_\_\_\_  
\_\_\_\_\_  
\_\_\_\_\_  
\_\_\_\_\_  
\_\_\_\_\_  
\_\_\_\_\_  
\_\_\_\_\_  
\_\_\_\_\_  
\_\_\_\_\_  
\_\_\_\_\_  
\_\_\_\_\_  
\_\_\_\_\_

OVERALL, how would you rate the quality of "ALL" Manuals of this type provided to you? (Check one.)

	Poor		Fair		Good		Very Good		Excellent	
1	2	3	4	5	6	7	8	9	10	

\_\_\_\_\_

Company Name \_\_\_\_\_

**THANK YOU!**

Address \_\_\_\_\_

Phone \_\_\_\_\_

FAX No. \_\_\_\_\_

Dealer Acct. No. \_\_\_\_\_

TE14778,000003F -19-19MAY04-1/1

*Introduction*

# Contents

## Section 00—General Information

- Group 01—Safety
- Group 03—Torque Values

## Section 01—Tracks

- Group 0130—Track System

## Section 02—Axles and Suspension Systems

- Group 0201—Drive Axle Housing and Support
- Group 0250—Axle Shaft, Bearings, and Reduction Gear

## Section 03—Transmission

- Group 0300—Removal and Installation
- Group 0315—Controls Linkage
- Group 0360—Hydrostatic System

## Section 04—Engine

- Group 0400—Removal and Installation

## Section 05—Engine Auxiliary Systems

- Group 0505—Cold Weather Starting Aids
- Group 0510—Radiator and Fan Shroud
- Group 0515—Engine Speed Control
- Group 0520—Intake System
- Group 0530—External Exhaust System
- Group 0540—Mounting Frame
- Group 0560—External Fuel Supply System

## Section 07—Dampener Drive

- Group 0752—Elements

## Section 11—Park Brake

- Group 1100—Removal and Installation
- Group 1115—Control Linkage
- Group 1160—Hydraulic System

## Section 18—Operator's Station

- Group 1800—Removal and Installation
- Group 1810—Operator's Enclosure
- Group 1821—Seat and Seat Belt
- Group 1830—Heating and Air Conditioning

## Section 19—Sheet Metal and Styling

- Group 1910—Hood and Engine Enclosure
- Group 1921—Grille and Grille Housing

## Section 21—Main Hydraulic System

- Group 2160—Hydraulic System

## Section 32—Bulldozer

- Group 3201—Blades
- Group 3215—Control Linkage
- Group 3240—Frames
- Group 3260—Hydraulic System

## Section 9900—Dealer Fabricated Tools

- Group 0999—Dealer Fabricated Tools

*Original Instructions. All information, illustrations and specifications in this manual are based on the latest information available at the time of publication. The right is reserved to make changes at any time without notice.*

COPYRIGHT © 2010  
DEERE & COMPANY  
Moline, Illinois  
All rights reserved.  
A John Deere ILLUSTRATION © Manual  
Previous Editions  
Copyright © 2004, 2006, 2008, 2009

*Contents*

## Section 00 General Information

### Contents

	Page
<b>Group 01—Safety .....</b>	<b>00-01-1</b>
<b>Group 03—Torque Values</b>	
Torque Value	
Metric Bolt and Cap Screw.....	00-03-1
Additional Metric Cap Screw	
Torque Values .....	00-03-2
Unified Inch Bolt and Cap Screw .....	00-03-3
Service Recommendations for	
37° Flare and 30° Cone Seat	
Connectors .....	00-03-4
Service Recommendations for	
O-Ring Boss Fittings.....	00-03-4
Service Recommendation	
O-Ring Boss Fittings In Aluminum HousingExcavators.....	00-03-6
Service Recommendations For	
Flared Connections—Straight or	
Tapered Threads .....	00-03-7
Service Recommendations For	
Flat Face O-Ring Seal Fittings .....	00-03-8
O-Ring Face Seal Fittings with SAE Inch Hex Nut and	
Stud End for High Pressure.....	00-03-9
O-Ring Face Seal Fittings with Metric Hex Nut and	
Stud End for Standard Pressure.....	00-03-11
O-Ring Face Seal Fittings with Metric Hex Nut and	
Stud End for High Pressure.....	00-03-13
Service Recommendations for	
Metric Series Four Bolt Flange	
Fitting.....	00-03-15
Service Recommendations For	
Inch Series Four Bolt Flange	
Fittings .....	00-03-16
Inch Series Four Bolt Flange Fitting	
For High Pressure Service	
Recommendations.....	00-03-17
Service Recommendations	
For Non-Restricted Banjo	
(Adjustable) Fittings.....	00-03-18
Service Recommendations For	
O-Ring Boss Fittings With	
Shoulder .....	00-03-19
Metric 24 O-Ring Seal DIN 20078.....	00-03-21

*Contents*

## Recognize Safety Information

**This is the safety alert symbol. When you see this symbol on your machine or in this manual, be alert for the potential of personal injury.**

Follow the precautions and safe operating practices highlighted by this symbol.

A signal word — DANGER, WARNING, or CAUTION — is used with the safety alert symbol. DANGER identifies the most serious hazards.

On your machine, DANGER signs are red in color, WARNING signs are orange, and CAUTION signs are yellow. DANGER and WARNING signs are located near specific hazards. General precautions are on CAUTION labels.



T133555 —UN—28AUG00

T133568 —19—28AUG00

TX03679,00016CC -19-05FEB10-1/1

## Follow Safety Instructions

Read the safety messages in this manual and on the machine. Follow these warnings and instructions carefully. Review them frequently. Keep safety signs in good condition. Replace missing or damaged safety signs. Be sure new equipment components and repair parts include the current safety signs. Replacement safety signs are available from your John Deere dealer.

Be sure all operators of this machine understand every safety message. Replace operator's manual and safety labels immediately if missing or damaged.



T133556 —UN—24AUG00

TX03679,00016F9 -19-14JAN08-1/1

## Operate Only If Qualified

Do not operate this machine unless the operator's manual has been read carefully, and you have been qualified by supervised training and instruction.

Operator should be familiar with the job site and surroundings before operating. Try all controls and

machine functions with the machine in an open area before starting to work.

Know and observe all safety rules that may apply to every work situation and work site.

TX03679,00016FA -19-03JAN07-1/1

### Wear Protective Equipment

Guard against injury from flying pieces of metal or debris; wear goggles or safety glasses.

Wear close fitting clothing and safety equipment appropriate to the job.

Prolonged exposure to loud noise can cause impairment or loss of hearing. Wear suitable hearing protection such as earmuffs or earplugs to protect against objectionable or uncomfortable loud noises.

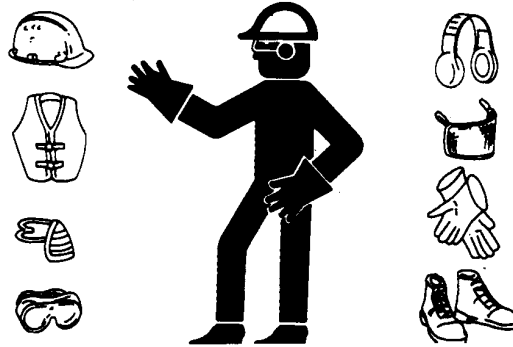

TS206—UN—23AUG88

TX03679,00016D0 -19-08JAN08-1/1

### Avoid Unauthorized Machine Modifications

Modifications of this machine, or addition of unapproved products or attachments, may affect machine stability or reliability, and may create a hazard for the operator or others near the machine. The installer of any modification which may affect the electronic controls of this machine is

responsible for establishing that the modification does not adversely affect the machine or its performance.

Always contact an authorized dealer before making machine modifications that change the intended use, weight or balance of the machine, or that alter machine controls, performance or reliability.

TX03679,00016B7 -19-12AUG03-1/1

### Inspect Machine

Inspect machine carefully each day by walking around it before starting.

Keep all guards and shields in good condition and properly installed. Fix damage and replace worn or broken parts immediately. Pay special attention to hydraulic hoses and electrical wiring.



T6607AQ—UN—18OCT88

TX03679,0001734 -19-08JAN08-1/1

### Stay Clear of Moving Parts

Entanglements in moving parts can cause serious injury.

Stop engine before examining, adjusting or maintaining any part of machine with moving parts.

Keep guards and shields in place. Replace any guard or shield that has been removed for access as soon as service or repair is complete.

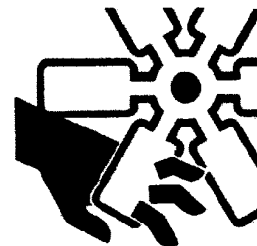

T133592—UN—12SEP01

TX03679,00016D2 -19-08JAN08-1/1

### Avoid High-Pressure Fluids

This machine uses a high-pressure hydraulic system. Escaping fluid under pressure can penetrate the skin causing serious injury.

**Never search for leaks with your hands.** Protect hands. Use a piece of cardboard to find location of escaping fluid. Stop engine and relieve pressure before disconnecting lines or working on hydraulic system.

**If hydraulic fluid penetrates your skin, see a doctor immediately. Injected fluid must be removed surgically within hours or gangrene may result.** Contact a knowledgeable medical source or the Deere & Company Medical Department in Moline, Illinois, U.S.A.

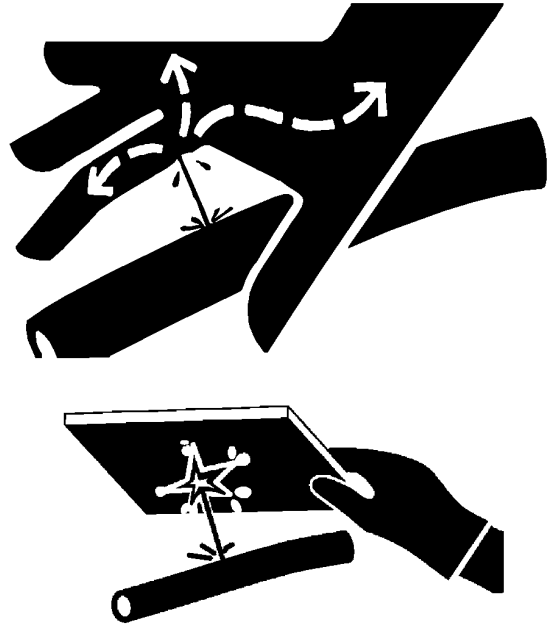

T133509—UN—17MAR06

T133840—UN—20SEP00

TX03679,00016D3 -19-07SEP06-1/1

### Beware of Exhaust Fumes

Prevent asphyxiation. Engine exhaust fumes can cause sickness or death.

If you must operate in an enclosed space, provide adequate ventilation. Use an exhaust pipe extension to remove the exhaust fumes or open doors and windows to bring outside air into the area.



T133546—UN—24AUG00

TX03679,00016D4 -19-23JUN08-1/1

## Prevent Fires

**Handle Fuel Safely:** Store flammable fluids away from fire hazards. Never refuel machine while smoking or when near sparks or flame.

**Clean Machine Regularly:** Keep trash, debris, grease and oil from accumulating in engine compartment, around fuel lines, hydraulic lines, exhaust components and electrical wiring. Never store oily rags or flammable materials inside a machine compartment.

**Maintain Hoses and Wiring:** Replace hydraulic hoses immediately if they begin to leak, and clean up any oil spills. Examine electrical wiring and connectors frequently for damage.

**Keep A Fire Extinguisher Available:** Always keep a multi-purpose fire extinguisher on or near the machine. Know how to use extinguisher properly.



T133553 —UN—07SEP00



T133554 —UN—07SEP00



T133552 —UN—14SEP00

TX03679,00016F5 -19-26JUN09-1/1

## Prevent Battery Explosions

Battery gas can explode. Keep sparks, lighted matches, and open flame away from the top of battery.

Never check battery charge by placing a metal object across the posts. Use a voltmeter or hydrometer.

Do not charge a frozen battery; it may explode. Warm battery to 16°C (60°F).



TS204 —UN—23AUG88

TX03679,000174A -19-08JAN08-1/1

## Handle Chemical Products Safely

Exposure to hazardous chemicals can cause serious injury. Under certain conditions, lubricants, coolants, paints and adhesives used with this machine may be hazardous.

If uncertain about safe handling or use of these chemical products, contact your authorized dealer for a Material Safety Data Sheet (MSDS) or go to internet website <http://www.jdmsds.com>. The MSDS describes physical and health hazards, safe use procedures, and emergency response techniques for chemical substances. Follow



MSDS recommendations to handle chemical products safely.

T133580 —UN—25AUG00

TX03679,00016D7 -19-03JAN07-1/1

### Dispose of Waste Properly

Improper disposal of waste can threaten the environment. Fuel, oils, coolants, filters and batteries used with this machine may be harmful if not disposed of properly.

Never pour waste onto the ground, down a drain, or into any water source.

Air conditioning refrigerants can damage the atmosphere. Government regulations may require using a certified service center to recover and recycle used refrigerants.

If uncertain about the safe disposal of waste, contact your local environmental or recycling center or your authorized dealer for more information.

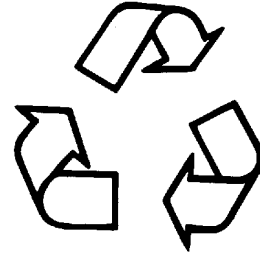

T133567 —UN—25AUG00

TX03679,0001733 -19-08JAN08-1/1

### Prepare for Emergencies

Be prepared if an emergency occurs or a fire starts.

Keep a first aid kit and fire extinguisher handy.

Keep emergency numbers for doctors, ambulance service, hospital, and fire department near your telephone.

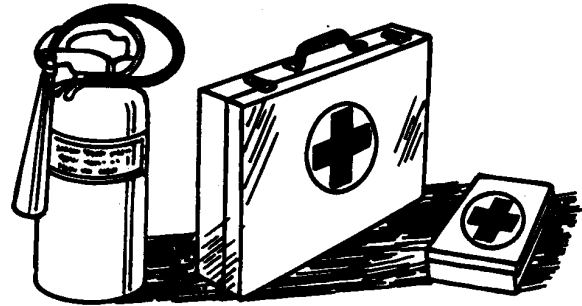

TS291 —UN—23AUG88

TX03679,000174B -19-08JAN08-1/1

### Add Cab Guarding For Special Uses

Special work situations or machine attachments may expose the operator to intruding or flying objects. Using this machine in a forestry application or woods environment, or with attachments such as a winch, requires added guarding to protect the operator.

Forestry protection packages or special screens should be installed when working in areas where logs or branches may strike the operator. A rear screen should always be used with a winch to protect against a snapping cable. Contact your authorized dealer for information on protective guarding before operating in any hazardous environment.

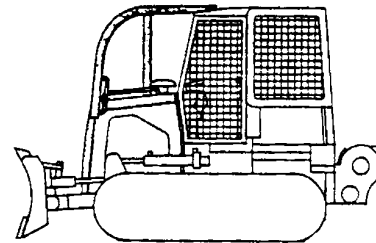

T139005 —UN—05MAR01

TX03768,0000B77 -19-14JAN08-1/1

### Start Only From Operator's Seat

Avoid unexpected machine movement. Before starting engine, sit in operator's seat. Ensure park lock lever is in "lock" position.

Never attempt to start engine from the ground or tracks. Do not attempt to start engine by shorting across the starter solenoid terminals.



T133715 —UN—07SEP00

TX03768,0000B71 -19-23FEB01-1/1

### Prevent Unintended Machine Movement

**Always move the park lock lever to the “lock” position before leaving the operator’s seat for any reason.**

Be careful not to accidentally actuate controls when co-workers are present. Engage park lock and lower work equipment to the ground during work interruptions. Stop the engine before allowing anyone to approach the machine. Follow these same precautions before standing up, leaving the operator’s seat, or exiting the machine.

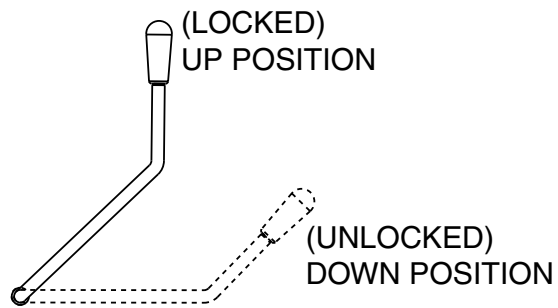

T159027 -19-30AUG02

TX03768,0000B72 -19-01MAY01-1/1

### Avoid Work Site Hazards

**Avoid contact with gas lines, buried cables and water lines.** Call utility line location services to identify all underground utilities before working below ground level.

**Avoid or correct hazardous work situations.** Avoid operating near structures or objects that could fall onto the machine. Clear away debris that could move unexpectedly if run over.

**Keep bystanders clear at all times.** Use barricades or a signal person to keep vehicles and pedestrians away. Always keep signal person in view. Instruct co-workers and bystanders not to approach the machine while it is operating.

**Operate only on solid footing** Use extra care when operating on stockpiles or near banks or excavations that may cave in and cause machine to tip or fall. Never allow the machine on a floor or structure until you are sure it will support the weight.

**Avoid contact with overhead electrical wires.** Stay clear of electrical lines. Never move any part of machine or load closer than 3 m (10 ft.) plus twice the line insulator length to overhead wires.

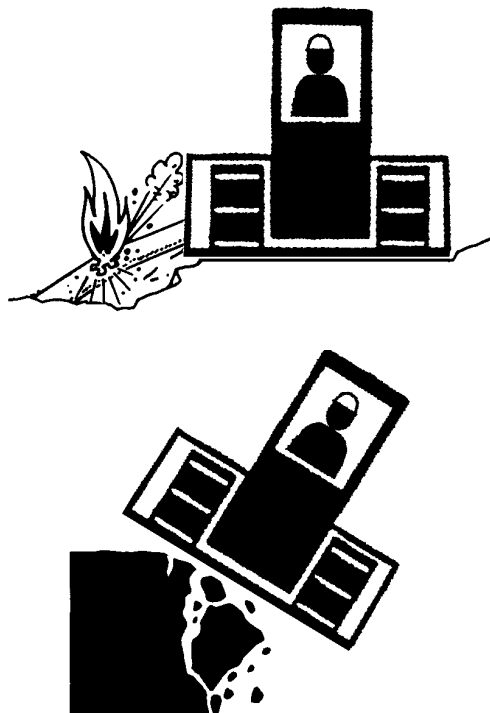

T139002 -UN-05MAR01

T139003 -UN-05MAR01

TX03768,0000B76 -19-06MAR01-1/1

### Keep Riders Off Machine

Only allow operator on machine.

Riders are subject to injury. They may fall from machine, be caught between machine parts, or be struck by foreign objects.

Riders may obstruct operator’s view or impair his ability to operate machine safely.

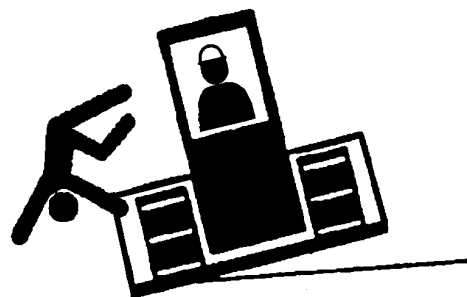

T137580 -UN-22FEB01

TX03768,0000B73 -19-03NOV08-1/1

### Avoid Backover Accidents

**Before moving machine, be sure all persons are clear of the machine path.** Turn around and look directly for best visibility. Use mirror to assist in checking behind the machine. Keep windows and mirror clean and in good repair.

**Be certain backup warning alarm is working properly.**

**Use a signal person when backing if view is obstructed or when in close quarters.** Keep signal person in view at all times. Use prearranged hand signals to communicate.

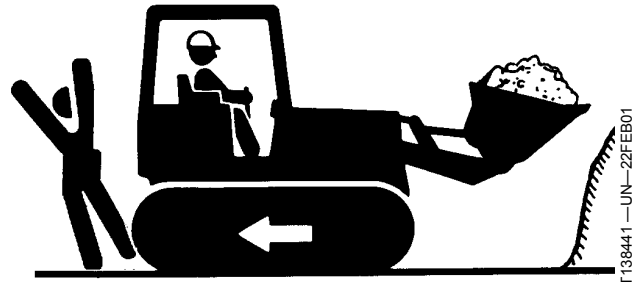

T138441 —UN—22FEB01

TX03768,0000B69 -19-14JAN08-1/1

### Avoid Machine Tip Over

**Use seat belt at all times.**

**Do not jump if the machine tips.** You will be unlikely to jump clear and the machine may crush you.

**Load and unload from trucks or trailers carefully.** Be sure truck is wide enough and secured on a firm level surface. Use loading ramps and attach them properly to truck bed. Avoid trucks with steel beds because tracks slip more easily on steel.

**Be careful on slopes.** Use extra care on soft, rocky or frozen ground because machine may slip sideways in these conditions. When traveling up or down steep slopes, keep the bucket or blade on uphill side and just above ground level.

**Ensure solid footing.** Use extra care when operating on stockpile materials, or near banks or excavations that may cave-in and cause machine to tip or fall.



**USE  
SEAT  
BELT**

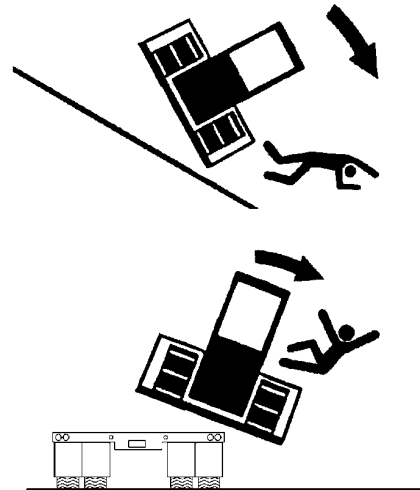

T133716 —19—14SEP00

T138416 —UN—22FEB01

T138415 —UN—22FEB01

TX03768,0000B6B -19-03NOV08-1/1

### Park And Prepare For Service Safely

**Warn others of service work.** Always park and prepare your machine for service or repair properly.

- Park machine on a level surface and lower blade/bucket and attachments to the ground.
- Place park lock lever in “lock” position. Stop engine and remove key.
- Attach a “Do Not Operate” tag in an obvious place in the operator’s station.

Securely support machine or attachment before working under it.

- Do not support machine with blade/bucket or attachments.
- Do not support machine with cinder blocks or wooden pieces that may crumble or crush.
- Do not support machine with a single jack or other devices that may slip out of place.

Understand service procedures before beginning repairs. Keep service area clean and dry. Use two people whenever the engine must be running for service work.

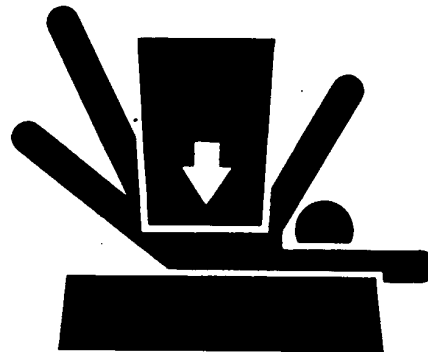

T133332 —19—14DEC01

TS229 —UN—23AUG88

TX03768,0000B6A -19-19OCT09-1/1

### Service Cooling System Safely

Explosive release of fluids from pressurized cooling system can cause serious burns.

Shut off engine. Only remove filler cap when cool enough to touch with bare hands. Slowly loosen cap to first stop to relieve pressure before removing completely.



TS281 —UN—23AUG88

DX,RCAP -19-04JUN90-1/1

### Remove Paint Before Welding or Heating

Avoid potentially toxic fumes and dust.

Hazardous fumes can be generated when paint is heated by welding, soldering, or using a torch.

Remove paint before heating:

- Remove paint a minimum of 100 mm (4 in.) from area to be affected by heating. If paint cannot be removed, wear an approved respirator before heating or welding.
- If you sand or grind paint, avoid breathing the dust. Wear an approved respirator.
- If you use solvent or paint stripper, remove stripper with soap and water before welding. Remove solvent or paint stripper containers and other flammable material from area. Allow fumes to disperse at least 15 minutes before welding or heating.

Do not use a chlorinated solvent in areas where welding will take place.

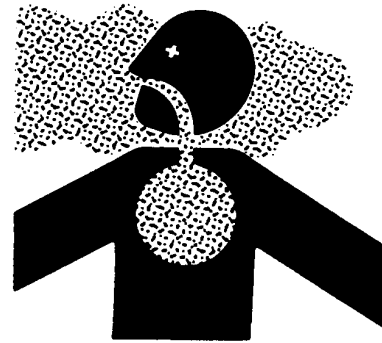

Do all work in an area that is well ventilated to carry toxic fumes and dust away.

Dispose of paint and solvent properly.

DX,PAINT -19-24JUL02-1/1

TS220—UN—23AUG88

### Make Welding Repairs Safely

**IMPORTANT: Disable electrical power before welding. Turn off main battery switch or disconnect positive battery cable. Separate harness connectors to engine and vehicle microprocessors.**

Avoid welding or heating near pressurized fluid lines. Flammable spray may result and cause severe burns if pressurized lines fail as a result of heating. Do not let heat go beyond work area to nearby pressurized lines.

Remove paint properly. Do not inhale paint dust or fumes. Use a qualified welding technician for structural repairs.



Make sure there is good ventilation. Wear eye protection and protective equipment when welding.

TX03679,00016D5 -19-11SEP09-1/1

T133547—UN—31AUG00

### Drive Metal Pins Safely

Always wear protective goggles or safety glasses and other protective equipment before striking hardened parts. Hammering hardened metal parts such as pins and bucket teeth may dislodge chips at high velocity.

Use a soft hammer or a brass bar between hammer and object to prevent chipping.

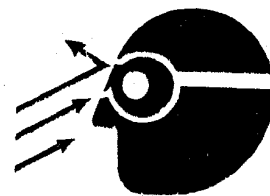

OOU1065,0000090 -19-03NOV08-1/1

T133738—UN—14SEP00



## Metric Bolt and Cap Screw Torque Values

METRIC BOLT AND CAP SCREW TORQUE VALUES—Tolerance is  $\pm 10\%$  unless otherwise specified

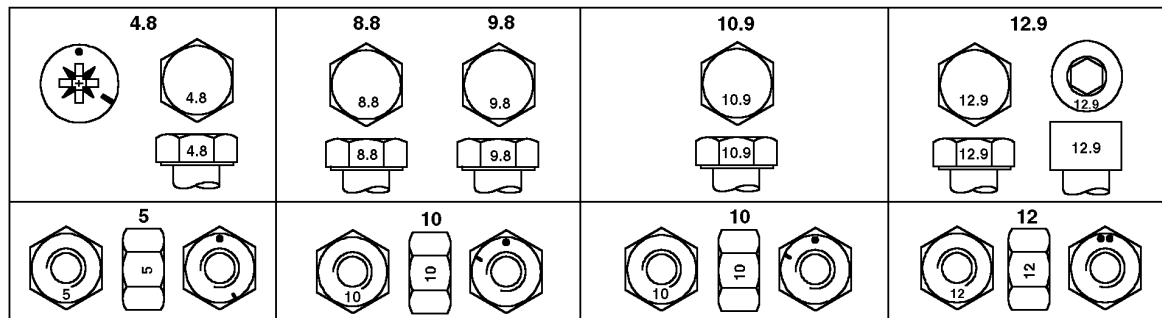

Top—Property Class and Head Markings; Bottom—Property Class and Nut Markings

Thread Size	Class 4.8		Class 8.8 or 9.8		Class 10.9		Class 12.9	
	Lubricated <sup>a</sup> Nm (lb-ft)	Dry <sup>b</sup> Nm (lb-ft)	Lubricated <sup>a</sup> Nm (lb-ft)	Dry <sup>b</sup> Nm (lb-ft)	Lubricated <sup>a</sup> Nm (lb-ft)	Dry <sup>b</sup> Nm (lb-ft)	Lubricated <sup>a</sup> Nm (lb-ft)	Dry <sup>b</sup> Nm (lb-ft)
M6	4.7 (3.5)	6 (4.4)	9 (6.6)	11.5 (8.5)	13 (9.5)	16.5 (12.2)	15.5 (11.5)	19.5 (14.5)
M8	11.5 (8.5)	14.5 (10.7)	22 (16)	28 (20.5)	32 (23.5)	40 (29.5)	37 (27.5)	47 (35)
M10	23 (17)	29 (21)	43 (32)	55 (40)	63 (46)	80 (59)	75 (55)	95 (70)
M12	40 (29.5)	50 (37)	75 (55)	95 (70)	110 (80)	140 (105)	130 (95)	165 (120)
M14	63 (46)	80 (59)	120 (88)	150 (110)	175 (130)	220 (165)	205 (150)	260 (190)
M16	100 (74)	125 (92)	190 (140)	240 (175)	275 (200)	350 (255)	320 (235)	400 (300)
M18	135 (100)	170 (125)	265 (195)	330 (245)	375 (275)	475 (350)	440 (325)	560 (410)
M20	190 (140)	245 (180)	375 (275)	475 (350)	530 (390)	675 (500)	625 (460)	790 (580)
M22	265 (195)	330 (245)	510 (375)	650 (480)	725 (535)	920 (680)	850 (625)	1080 (800)
M24	330 (245)	425 (315)	650 (480)	820 (600)	920 (680)	1150 (850)	1080 (800)	1350 (1000)
M27	490 (360)	625 (460)	950 (700)	1200 (885)	1350 (1000)	1700 (1250)	1580 (1160)	2000 (1475)
M30	660 (490)	850 (625)	1290 (950)	1630 (1200)	1850 (1350)	2300 (1700)	2140 (1580)	2700 (2000)
M33	900 (665)	1150 (850)	1750 (1300)	2200 (1625)	2500 (1850)	3150 (2325)	2900 (2150)	3700 (2730)
M36	1150 (850)	1450 (1075)	2250 (1650)	2850 (2100)	3200 (2350)	4050 (3000)	3750 (2770)	4750 (3500)

<sup>a</sup> "Lubricated" means coated with a lubricant such as engine oil, or fasteners with phosphate and oil coatings.

<sup>b</sup> "Dry" means plain or zinc plated without any lubrication.

**CAUTION:** Use only metric tools on metric hardware. Other tools may not fit properly. Tool may slip and cause injury.

DO NOT use these values if a different torque value or tightening procedure is given for a specific application. Torque values listed are for general use only. Check tightness of fasteners periodically.

Shear bolts are designed to fail under predetermined loads. Always replace shear bolts with identical property class.

Fasteners should be replaced with the same or higher property class. If higher property class fasteners are used, these should only be tightened to the strength of the original.

Make sure fastener threads are clean and that you properly start thread engagement. This will prevent them from failing when tightening.

Tighten plastic insert or crimped steel-type lock nuts to approximately 50 percent of the dry torque shown in the chart, applied to the nut, not to the bolt head. Tighten toothed or serrated-type lock nuts to the full torque value.

OUT3035,TORQUE2 -19-22MAR04-1/1

TORQ2—UN—07SEP99

### Additional Metric Cap Screw Torque Values

**⚠ CAUTION: Use only metric tools on metric hardware. Other tools may not fit properly. They may slip and cause injury.**

Check tightness of cap screws periodically. Torque values listed are for general use only. Do not use these values if a different torque value or tightening procedure is listed for a specific application.

Shear bolts are designed to fail under predetermined loads. Always replace shear bolts with identical grade.

Fasteners should be replaced with the same or higher grade. If higher grade fasteners are used, these should only be tightened to the strength of the original.

Make sure fastener threads are clean and you properly start thread engagement. This will prevent them from failing when tightening.

Tighten cap screws having lock nuts to approximately 50 percent of amount shown in chart.



T6873AA

T6873AA —UN—18OCT88



T6873AB

T6873AB —UN—18OCT88



T6873AC

T6873AC —UN—18OCT88

aMETRIC CAP SCREW TORQUE VALUES						
Nominal Dia	T-Bolt		H-Bolt		M-Bolt	
	N·m	lb-ft	N·m	lb-ft	N·m	lb-ft
8	29	21	20	15	10	7
10	63	46	45	33	20	15
12	108	80	88	65	34	25
14	176	130	137	101	54	40
16	265	195	206	152	78	58
18	392	289	294	217	118	87
20	539	398	392	289	167	125
22	735	542	539	398	216	159
24	931	687	686	506	274	202
27	1372	1012	1029	759	392	289
30	1911	1410	1421	1049	539	398
33	2548	1890	1911	1410	735	542
36	3136	2314	2401	1772	931	687

<sup>a</sup>Torque tolerance is ±10%.

Torque Values

**Unified Inch Bolt and Cap Screw Torque Values**

UNIFIED INCH BOLT AND CAP SCREW TORQUE VALUES—Tolerance is ±10% unless otherwise specified

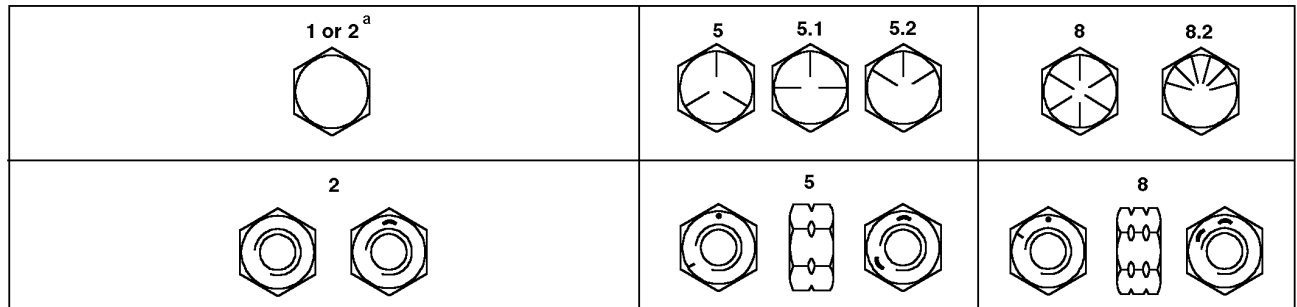

Top—SAE Grade and Head Markings; Bottom—SAE Grade and Nut Markings

Thread Size	Grade 1 (No Mark)		Grade 2 <sup>a</sup> (No Mark)		Grade 5, 5.1 or 5.2		Grade 8 or 8.2	
	Lubricated <sup>b</sup> N·m (lb-ft)	Dry <sup>c</sup> N·m (lb-ft)	Lubricated <sup>b</sup> N·m (lb-ft)	Dry <sup>c</sup> N·m (lb-ft)	Lubricated <sup>b</sup> N·m (lb-ft)	Dry <sup>c</sup> N·m (lb-ft)	Lubricated <sup>b</sup> N·m (lb-ft)	Dry <sup>c</sup> N·m (lb-ft)
1/4	3.8 (2.8)	4.7 (3.5)	6 (4.4)	7.5 (5.5)	9.5 (7)	12 (9)	13.5 (10)	17 (12.5)
5/16	7.7 (5.7)	9.8 (7.2)	12 (9)	15.5 (11.5)	19.5 (14.5)	25 (18.5)	28 (20.5)	35 (26)
3/8	13.5 (10)	17.5 (13)	22 (16)	27.5 (20)	35 (26)	44 (32.5)	49 (36)	63 (46)
7/16	22 (16)	28 (20.5)	35 (26)	44 (32.5)	56 (41)	70 (52)	80 (59)	100 (74)
1/2	34 (25)	42 (31)	53 (39)	67 (49)	85 (63)	110 (80)	120 (88)	155 (115)
9/16	48 (35.5)	60 (45)	76 (56)	95 (70)	125 (92)	155 (115)	175 (130)	220 (165)
5/8	67 (49)	85 (63)	105 (77)	135 (100)	170 (125)	215 (160)	240 (175)	305 (225)
3/4	120 (88)	150 (110)	190 (140)	240 (175)	300 (220)	380 (280)	425 (315)	540 (400)
7/8	190 (140)	240 (175)	190 (140)	240 (175)	490 (360)	615 (455)	690 (510)	870 (640)
1	285 (210)	360 (265)	285 (210)	360 (265)	730 (540)	920 (680)	1030 (760)	1300 (960)
1-1/8	400 (300)	510 (375)	400 (300)	510 (375)	910 (670)	1150 (850)	1450 (1075)	1850 (1350)
1-1/4	570 (420)	725 (535)	570 (420)	725 (535)	1280 (945)	1630 (1200)	2050 (1500)	2600 (1920)
1-3/8	750 (550)	950 (700)	750 (550)	950 (700)	1700 (1250)	2140 (1580)	2700 (2000)	3400 (2500)
1-1/2	990 (730)	1250 (930)	990 (730)	1250 (930)	2250 (1650)	2850 (2100)	3600 (2650)	4550 (3350)

<sup>a</sup> Grade 2 applies for hex cap screws (not hex bolts) up to 6 in. (152 mm) long. Grade 1 applies for hex cap screws over 6 in. (152 mm) long, and for all other types of bolts and screws of any length.

<sup>b</sup> "Lubricated" means coated with a lubricant such as engine oil, or fasteners with phosphate and oil coatings.

<sup>c</sup> "Dry" means plain or zinc plated without any lubrication.

DO NOT use these values if a different torque value or tightening procedure is given for a specific application. Torque values listed are for general use only. Check tightness of fasteners periodically.

Shear bolts are designed to fail under predetermined loads. Always replace shear bolts with identical grade.

Fasteners should be replaced with the same or higher grade. If higher grade fasteners are used, these should only be tightened to the strength of the original.

Make sure fastener threads are clean and that you properly start thread engagement. This will prevent them from failing when tightening.

Tighten plastic insert or crimped steel-type lock nuts to approximately 50 percent of the dry torque shown in the chart, applied to the nut, not to the bolt head. Tighten toothed or serrated-type lock nuts to the full torque value.

OUT3035,TORQUE1 -19-14JAN04-1/1

TORQ1A—UN—27SEP99

### Service Recommendations for 37° Flare and 30° Cone Seat Connectors

1. Inspect flare and flare seat. They must be free of dirt or obvious defects.
2. Defects in tube flare cannot be repaired. Overtightening a defective flared fitting will not stop leaks.
3. Align tube with fitting before attempting to start nut.
4. Lubricate male threads with hydraulic fluid or petroleum jelly.
5. Index angle fittings and tighten by hand.
6. Tighten fitting or nut to torque value shown on torque chart. Do not allow hoses to twist when tightening fittings.

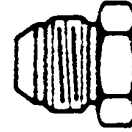

T6234AC —UN—18OCT88

STRAIGHT FITTING OR SPECIAL NUT TORQUE CHART		
Thread Size	N·m	lb·ft
3/8 - 24 UNF	8	6
7/16 - 20 UNF	12	9
1/2 - 20 UNF	16	12
9/16 - 18 UNF	24	18
3/4 - 16 UNF	46	34
7/8 - 14 UNF	62	46
1-1/16 - 12 UN	102	75
1-3/16 - 12 UN	122	90
1-5/16 - 12 UN	142	105
1-5/8 - 12	190	140
1-7/8 - 12 UN	217	160

NOTE: Torque tolerance is  $\pm 10\%$ .

T82,BHMA,EL -19-29SEP99-1/1

### Service Recommendations for O-Ring Boss Fittings

#### Straight Fitting

1. Inspect O-ring boss seat for dirt or defects.
2. Lubricate O-ring with petroleum jelly. Place electrical tape over threads to protect O-ring. Slide O-ring over tape and into O-ring groove of fitting. Remove tape.
3. Tighten fitting to torque value shown on chart.

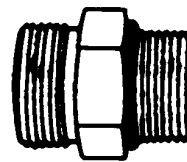

T6243AE —UN—18OCT88

Continued on next page

04T,90,K66 -19-29SEP99-1/2

**Angle Fitting**

1. Back-off lock nut (A) and back-up washer (B) completely to head-end (C) of fitting.
2. Turn fitting into threaded boss until back-up washer contacts face of boss.
3. Turn fitting head-end counterclockwise to proper index (maximum of one turn).

*NOTE: Do not allow hoses to twist when tightening fittings.*

4. Hold fitting head-end with a wrench and tighten locknut and back-up washer to proper torque value.

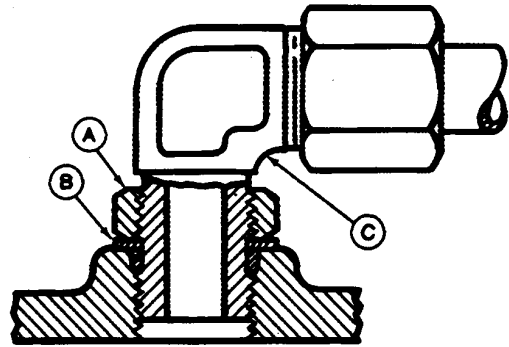

T6520AB —UN—18OCT88

**STRAIGHT FITTING OR SPECIAL NUT TORQUE CHART**

Thread Size	N-m	lb-ft
3/8-24 UNF	8	6
7/16-20 UNF	12	9
1/2-20 UNF	16	12
9/16-18 UNF	24	18
3/4-16 UNF	46	34
7/8-14 UNF	62	46
1-1/16-12 UN	102	75
1-3/16-12 UN	122	90
1-5/16-12 UN	142	105
1-5/8-12 UN	190	140
1-7/8-12 UN	217	160

*NOTE: Torque tolerance is ± 10%.*

04T,90,K66 -19-29SEP99-2/2

### O-Ring Boss Fittings In Aluminum Housing Service Recommendations—Excavators

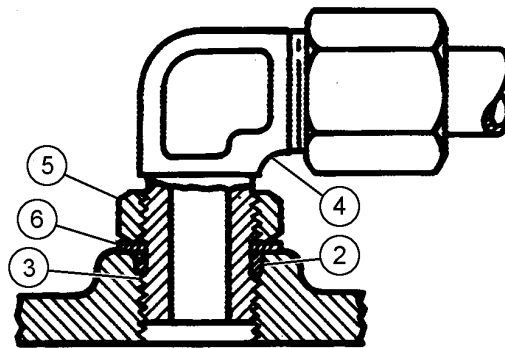
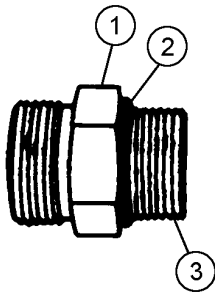

T196315

O-Ring Boss Straight and Adjustable Fittings

1— Straight Fitting  
2— O-Ring

3— Stud End  
4— Adjustable Fitting

5— Hex Nut  
6— Backup Washer

T196315—UN—17NOV03

O-RING BOSS STRAIGHT OR ADJUSTABLE FITTING STUD END NUT WITH METRIC THREAD IN ALUMINUM HOUSING TORQUE VALUES—Tolerance is $\pm 10\%$ unless otherwise specified		
Thread Size mm	Hex Nut Size mm	Nm (lb-ft)
M12 x 1.5	17	39 (29)
M14 x 1.5	19	39 (29)
M16 x 1.5	22	55 (41)
M22 x 1.5	27	75 (55)
M27 x 2	32	110 (81)
M30 x 2	36	141 (104)
M33 x 2	41	165 (122)
M38 x 2	46	165 (122)
M42 x 2	50	275 (203)

O-RING BOSS PLUG STUD END WITH INCH THREAD IN ALUMINUM HOUSING TORQUE VALUES—Tolerance is $\pm 10\%$ unless otherwise specified		
Thread Size in.	Nm (lb-ft)	
1/8	7.8	(5.80)
1/4	11.8	(8.70)
3/8	23	(17)
1/2	39	(29)
3/4	55	(41)
1	86	(64)
1-1/4	126	(93)
1-1/2	157	(116)
2	204	(150)

O-RING BOSS STRAIGHT OR ADJUSTABLE FITTING STUD END NUT WITH INCH THREAD IN ALUMINUM HOUSING TORQUE VALUES—Tolerance is $\pm 10\%$ unless otherwise specified	
Thread Size in.	Nm (lb-ft)
1/8	—
1/4	28 (20)
3/8	39 (29)
1/2	75 (55)
3/4	126 (93)
1	165 (122)
1-1/8	—
1-1/4	259 (191)
1-3/8	—
1-1/2	330 (243)
1-3/4	—
2	—

1. Inspect fitting and O-ring boss sealing surfaces and the O-ring. They must be free of dirt, scratches, nicks, or burrs. O-ring must be free of dirt, cuts, cracks, swelling or flatten condition.
2. Back the stud end hex nut (5) off as far as possible. Push backup washer (6) towards the nut to fully expose the turn down section of stud end. Washer must fit turned down section and not be too loose
3. Wrap electrical tape over threads to protect O-ring. Slide O-ring over the tape into turned down section. Remove tape. Apply hydraulic oil to the threads of stud end, turned down section, and O-ring.
4. Turn fitting into the boss by hand until face of nut or backup washer squeezes O-ring into the seat and contacts face of boss. Loosen an adjustable fitting no more than one turn for alignment.
5. Tighten straight fitting or hex nut to the torque value given. Hold body of adjustable fitting using a second wrench when tightening hex nut.

OUT3035,0000353 -19-28MAY09-1/1

**Service Recommendations For Flared Connections—Straight or Tapered Threads**

1. Inspect flare and flare seat. They must be free of dirt or obvious defects.
2. Defects in the tube flare cannot be repaired. Overtightening a defective flared fitting will not stop leaks.
3. Align the tube with the fitting before attempting to start the nut.
4. Lubricate the male threads with hydraulic fluid or petroleum jelly.
5. Index angle fittings and tighten by hand.
6. Tighten fitting or nut to torque value shown on the chart. Do not allow hoses to twist when tightening fittings.

TORQUE CHART <sup>a</sup>				
Thread Size	Straight Thread <sup>b</sup>		Tapered Thread	
	N·m	lb-ft	N·m	lb-ft
1/8	15	11		
1/4	20	15	45	33
3/8	29	21	69	51
1/2	49	36	93	69
3/4	69	51	176	130
1	157	116	343	253
1-1/2	196	145	539	398
2	255	188	588	434

<sup>a</sup>Torque tolerance is ±10%.

<sup>b</sup>With seat face.

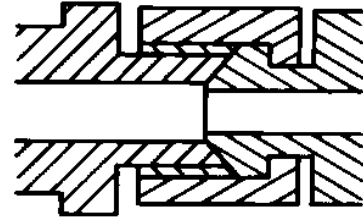

T6873AE

Straight Thread

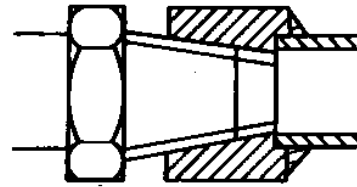

T6873AD

Tapered Thread

**NOTE:** If female thread is cast iron (control valves, brake valves motors, etc.), torque must be reduced approximately 10%.

T6873AE —UN—18OCT88

T6873AD —UN—18OCT88

### Service Recommendations For Flat Face O-Ring Seal Fittings

1. Inspect the fitting sealing surfaces and O-ring. They must be free of dirt or defects.
2. Lubricate O-rings and install into groove using petroleum jelly to hold in place.
3. Index angle fittings and tighten by hand pressing joint together to insure O-ring remains in place.
4. Tighten fitting or nut to torque value shown on the chart. Do not allow hoses to twist when tightening fittings, use backup wrench on straight hose couplings.

**IMPORTANT: Tighten fittings to 150% of listed torque value if indexing is necessary or if fitting is attached to an actuating device.**

**Tighten fittings to 50% of listed torque value if used in aluminum housing.**

FLAT FACE O-RING SEAL FITTING TORQUE*						
Nomial Tube O.D.		Thread Size	Swivel Nut		Bulkhead Nut	
mm	in.	in.	N-m	lb-ft	N-m	lb-ft
6.35	0.250	9/16-18	16	12	12	9
9.52	0.375	11/16-16	24	18	24	18
12.70	0.500	13/16-16	50	37	46	34
15.88	0.625	1-14	69	51	62	46
19.05	0.750	1 3/16-12	102	75	102	75
22.22	0.875	1 3/16-12	102	75	102	75
25.40	1.000	1 7/16-12	142	105	142	105
31.75	1.250	1 11/16-12	190	140	190	140
38.10	1.500	2-12	217	160	217	160

\*Torque tolerance is +15 -20% unless otherwise specified.

Stud End O-ring Seal Torque for Straight and Adjustable Fittings*				
Thread Size	Straight Hex Size	Locknut Hex Size	Straight Fitting or Locknut Toque	
Inch	Inch	Inch	N-m	lb-ft
3/8-24	5/8	9/16	12	9
7/16-20	5/8	5/8	21	15
1/2-20	3/4	11/16	26	19
9/16-18	3/4	3/4	34	25
3/4-16	7/8	15/16	73	55
7/8-14	1 1/16	1 1/16	104	76
1 1/16-12	1 1/4	1 3/8	176	130
1 3/16-12	1 3/8	1 1/2	230	170
1 5/16-12	1 1/2	1 5/8	285	210

\*Torque tolerance is +15 -20% unless otherwise specified.

04T,90,K67 -19-02MAR00-1/1

### O-Ring Face Seal Fittings With SAE Inch Hex Nut And Stud End For High Pressure Service Recommendations

O-RING FACE SEAL FITTINGS WITH SAE INCH HEX NUT AND STUD END FOR HIGH PRESSURE, ABOVE 27 600 kPa (276 bar) (4000 psi), TORQUE VALUES—Tolerance is +15 -20% unless otherwise specified

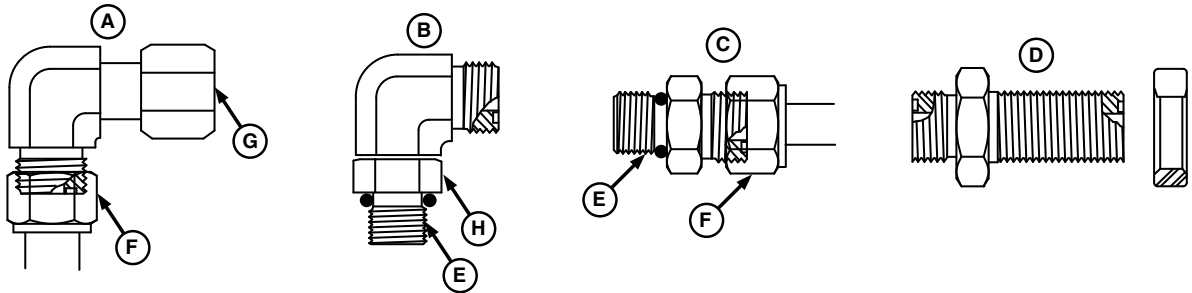

A—90° Swivel Elbow and Tube Nut  
 B—90° Adjustable Stud Elbow  
 C—Stud Straight and Tube Nut  
 D—Bulkhead Union and Nut  
 E—Stud End  
 F—Tube Nut  
 G—Swivel Nut  
 H—Hex Nut

Nominal Tube OD or Hose ID			O-Ring Face Seal Hose or Tube Swivel Nut			Bulkhead Nut	
Metric Tube OD	Inch Tube OD or Hose ID		Thread Size	Hex Size	Torque	Hex Size	Torque
mm	Dash Size	mm (in.)	in.	in.	Nm (lb-ft)	in.	Nm (lb-ft)
5	-3	4.78 (0.188)	—	—	—	—	—
6	-4	6.35 (0.250)	9/16-18	11/16	24 (18)	13/16	32 (24)
8	-5	7.92 (0.312)	—	—	—	—	—
10	-6	9.53 (0.375)	11/16-16	13/16	37 (27)	1	42 (31)
12	-8	12.70 (0.500)	13/16-16	15/16	75 (55)	1-1/8	93 (69)
16	-10	15.88 (0.625)	1-14	1-1/8	103 (76)	1-5/16	118 (87)
20	-12	19.05 (0.750)	1-3/16-12	1-3/8	152 (112)	1-1/2	175 (129)
22	-14	22.23 (0.875)	1-3/16-12	—	152 (112)	—	175 (129)
25	-16	25.40 (1.000)	1-7/16-12	1-5/8	214 (158)	1-3/4	247 (182)
32	-20	31.75 (1.250)	1-11/16-12	1-7/8	286 (211)	2	328 (242)
38	-24	38.10 (1.500)	2-12	2-1/4	326 (240)	2-3/8	374 (276)

O-RING STRAIGHT, ADJUSTABLE, AND EXTERNAL HEX PLUG WITH SAE INCH STUD END FOR HIGH PRESSURE, ABOVE 27 600 kPa (276 bar) (4000 psi), TORQUE VALUES—Tolerance is +15 -20% unless otherwise specified

Thread Size	Straight Hex Size <sup>a</sup>	Adjustable Nut Hex Size	Steel or Gray Iron Torque
in.	in.	in.	Nm (lb-ft)
3/8-24	5/8	9/16	18 (13)
7/16-20	5/8	5/8	24 (18)
1/2-20	3/4	11/16	30 (22)
9/16-18	3/4	3/4	37 (27)
3/4-16	7/8	15/16	75 (55)
7/8-14	1-1/16	1-1/16	103 (76)
1-1/16-12	1-1/4	1-3/8	177 (131)
1-3/16-12	1-3/8	1-1/2	231 (170)
1-5/16-12	1-1/2	1-5/8	270 (199)
1-5/8-12	1-3/4	1-7/8	286 (211)
1-7/8-12	2-1/8	2-1/8	326 (240)

<sup>a</sup> Straight hex size applies to fittings only and may not be the same as the corresponding plug of the same thread size.

1. Inspect fitting and connector sealing surfaces and the O-rings. They must be free of dirt, scratches, nicks, and burrs. O-ring must be free of dirt, cuts, cracks, swelling or flatten condition.
2. Back the stud end hex nut off as far as possible. Push backup washer towards the nut to fully expose the turn down section. Washer must fit turned down section and not be too loose

Continued on next page

OUT3035.0000420 -19-04MAY09-1/2

H70406—UN—12DEC01

## Torque Values

3. Lubricate O-rings using a thin film of clean hydraulic oil or as needed, petroleum jelly to hold O-ring in place.

Install O-ring into groove making sure it is seated at the bottom. Excess petroleum jelly will prevent seating of O-ring and cause it to pop out.

To protect an O-ring from threads, wrap electrical tape over the threads. Slide O-ring over the tape into the turned down section. Remove the tape.

4. Turn fitting into the boss by hand until face of nut or washer squeezes the O-ring into the seat and contacts

face of boss. Loosen adjustable fittings no more than one turn for alignment.

Hold connections together while tightening nut to ensure O-ring remains in place.

5. Tighten fitting or nut to torque value shown. Use a second wrench to hold the fitting in position or to keep hose from twisting while tightening nut.

OUT3035,0000420 -19-04MAY09-2/2

### O-Ring Face Seal Fittings With Metric Hex Nut And Stud End For Standard Pressure Service Recommendations

O-RING FACE SEAL AND FITTINGS WITH METRIC HEX NUT AND STUD END FOR STANDARD PRESSURE, BELOW 27 600 kPa (275.8 bar) (4,000 psi), TORQUE VALUES—Tolerance is +15 -20% unless otherwise specified

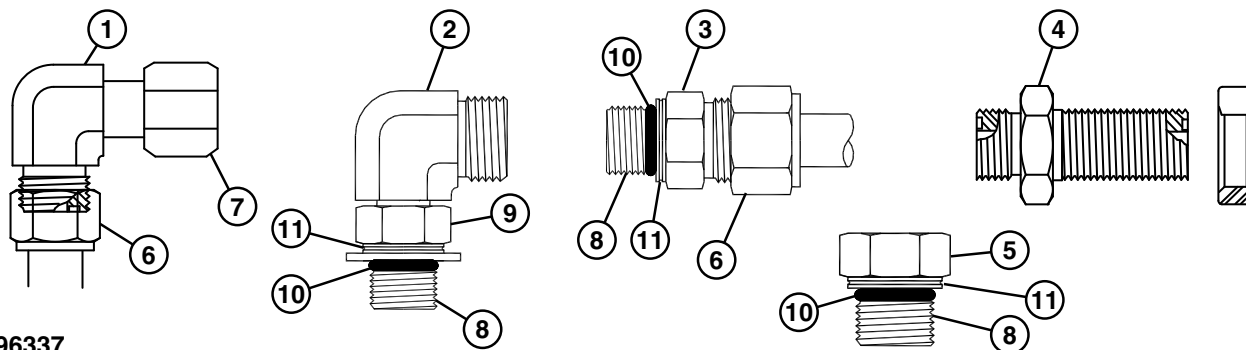

T196337

- 1— 90° Swivel Elbow
- 2— 90° Adjustable Stud Elbow
- 3— Stud Straight
- 4— Bulkhead Union and Nut
- 5— External Hex Stud End Plug
- 6— Tube Nut
- 7— Swivel Nut
- 8— Stud End
- 9— Hex Nut
- 10— O-Ring
- 11— Identification Groove

Nominal Tube OD or Hose ID			O-Ring Face Seal Hose or Tube Swivel Nut			Bulkhead Nut	
Metric Tube OD	Inch Tube OD or Hose ID		Thread Size	Hex Size	Torque	Hex Size	Torque
mm	Dash Size	mm (in.)	in.	mm	Nm (lb-ft)	mm	Nm (lb-ft)
4	-2	3.18 (0.125)	—	—	—	—	—
5	-3	4.78 (0.188)	—	—	—	—	—
6	-4	6.35 (0.250)	9/16-18	17	16 (12)	22	32 (24)
8	-5	7.92 (0.312)	—	—	—	—	—
10	-6	9.53 (0.375)	11/16-16	22	24 (18)	27	42 (31)
12	-8	12.70 (0.500)	13/16-16	24	50 (37)	30	93 (69)
16	-10	15.88 (0.625)	1-14	30	69 (51)	36	118 (87)
20	-12	19.05 (0.750)	1-3/16-12	36	102 (75)	41	175 (129)
22	-14	22.23 (0.875)	1-3/16-12	36	102 (75)	41	175 (129)
25	-16	25.40 (1.000)	1-7/16-12	41	142 (105)	46	247 (182)
28	—	—	—	—	—	—	—
32	-20	31.75 (1.250)	1-11/16-12	50	190 (140)	50	328 (242)
38	-24	38.10 (1.500)	2-12	60	217 (160)	60	374 (276)
50	-32	50.80 (2.000)	—	—	—	—	—

O-RING STRAIGHT, ADJUSTABLE, AND EXTERNAL HEX PLUG WITH METRIC STUD END FOR STANDARD PRESSURE, BELOW 27 600 kPa (275.8 bar) (4,000 psi), TORQUE VALUES—Tolerance is +15 -20% unless otherwise specified

Thread Size <sup>a</sup>	Straight Hex Size <sup>b</sup>	Adjustable Nut Hex Size	Steel or Gray Iron Torque	Aluminum or Brass Torque
mm.	mm	mm	Nm (lb-ft)	Nm (lb-ft)
M8 x 1	12	12	8 (6)	5 (4)
M10 x 1	14	14	15 (11)	10 (7)
M12 x 1.5	17	17	25 (18)	17 (12)
M14 x 1.5	19	19	40 (30)	27 (20)
M16 x 1.5	22	22	45 (33)	30 (22)
M18 x 1.5	24	24	50 (37)	33 (25)
M22 x 1.5	27	27	69 (51)	46 (34)
M27 x 2	32	32	100 (74)	67 (49)
M30 x 2	36	36	130 (96)	87 (64)
M33 x 2	41	41	160 (118)	107 (79)
M38 x 2	46	46	176 (130)	117 (87)
M42 x 2	50	50	210 (155)	140 (103)

Continued on next page

OUT3035.0000366 -19-28MAY09-1/2

T196337 —UN—18NOV03

## Torque Values

**O-RING STRAIGHT, ADJUSTABLE, AND EXTERNAL HEX PLUG WITH METRIC STUD END FOR STANDARD PRESSURE, BELOW 27 600 kPa (275.8 bar) (4,000 psi), TORQUE VALUES—Tolerance is +15 -20% unless otherwise specified**

Thread Size <sup>a</sup>	Straight Hex Size <sup>b</sup>	Adjustable Nut Hex Size	Steel or Gray Iron Torque	Aluminum or Brass Torque
mm.	mm	mm	Nm (lb-ft)	Nm (lb-ft)
M48 x 2	55	55	260 (192)	173 (128)
M60 x 2	65	65	315 (232)	210 (155)

<sup>a</sup> Stud end threads are identified as metric by an identification groove in the hex nut next to the O-ring.

<sup>b</sup> Straight hex size applies to fittings only and may not be the same as the corresponding plug of the same thread size.

1. Inspect fitting and connector sealing surfaces and the O-rings. They must be free of dirt, scratches, nicks, and burrs. O-ring must be free of dirt, cuts, cracks, swelling or flatten condition.
2. Back the stud end hex nut off as far as possible. Push backup washer towards the nut to fully expose the turn down section. Washer must fit turned down section and not be too loose
3. Lubricate O-rings using a thin film of clean hydraulic oil or as needed, petroleum jelly to hold O-ring in place.  
  
Install O-ring into groove making sure it is seated at the bottom. Excess petroleum jelly will prevent seating of O-ring and cause it to pop out.
4. Turn fitting into the boss by hand until face of nut or washer squeezes the O-ring into the seat and contacts face of boss. Loosen adjustable fittings no more than one turn for alignment.  
  
Hold connections together while tightening nut to ensure O-ring remains in place.
5. Tighten fitting or nut to torque value shown. Use a second wrench to hold the fitting in position or to keep hose from twisting while tightening nut.

OUT3035,0000366 -19-28MAY09-2/2

### O-Ring Face Seal Fittings With Metric Hex Nut And Stud End For High Pressure Service Recommendations

O-RING FACE SEAL FITTINGS WITH METRIC HEX NUT AND STUD END FOR HIGH PRESSURE, ABOVE 27 600 kPa (275.8 bar) (4,000 psi), TORQUE VALUES—Tolerance is +15 -20% unless otherwise specified

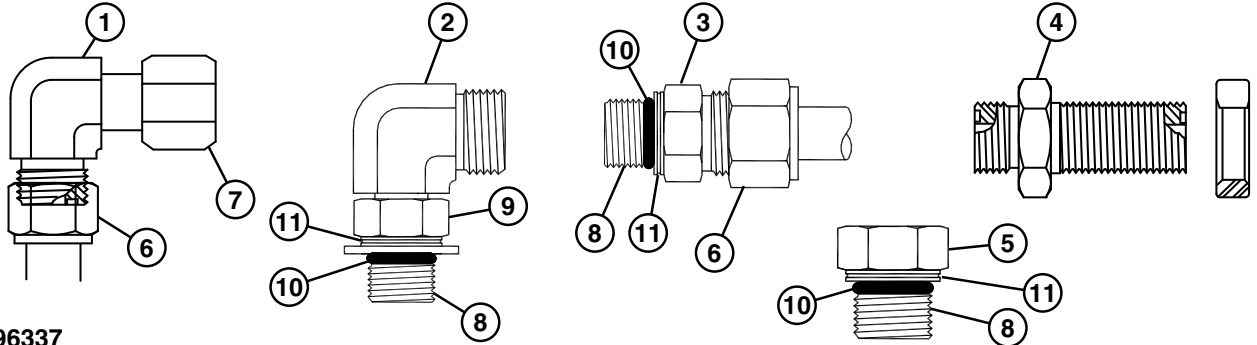

T196337

- 1— 90° Swivel Elbow
- 2— 90° Adjustable Stud Elbow
- 3— Stud Straight
- 4— Bulkhead Union and Nut
- 5— External Hex Stud End Plug
- 6— Tube Nut
- 7— Swivel Nut
- 8— Stud End
- 9— Hex Nut
- 10— O-Ring
- 11— Identification Groove

Nominal Tube OD or Hose ID			O-Ring Face Seal Hose or Tube Swivel Nut			Bulkhead Nut	
Metric Tube OD	Inch Tube OD or Hose ID		Thread Size	Hex Size	Torque	Hex Size	Torque
mm	Dash Size	mm (in.)	in.	mm	Nm (lb-ft)	mm	Nm (lb-ft)
4	-2	3.18 (0.125)	—	—	—	—	—
5	-3	4.78 (0.188)	—	—	—	—	—
6	-4	6.35 (0.250)	9/16-18	17	24 (18)	22	32 (24)
8	-5	7.92 (0.312)	—	—	—	—	—
10	-6	9.53 (0.375)	11/16-16	22	37 (27)	27	42 (31)
12	-8	12.70 (0.500)	13/16-16	24	75 (55)	30	93 (69)
16	-10	15.88 (0.625)	1-14	30	103 (76)	36	118 (87)
20	-12	19.05 (0.750)	1-3/16-12	36	152 (112)	41	175 (129)
22	-14	22.23 (0.875)	1-3/16-12	36	152 (112)	41	175 (129)
25	-16	25.40 (1.000)	1-7/16-12	41	214 (158)	46	247 (182)
28	—	—	—	—	—	—	—
32	-20	31.75 (1.250)	1-11/16-12	—	286 (211)	50	328 (242)
38	-24	38.10 (1.500)	2-12	—	326 (240)	60	374 (276)

O-RING STRAIGHT, ADJUSTABLE, AND EXTERNAL HEX PLUG WITH METRIC STUD END FOR HIGH PRESSURE, ABOVE 27 600 KPA (275.8 BAR) (4,000 PSI), TORQUE VALUES—Tolerance is +15 -20% unless otherwise specified

Thread Size <sup>a</sup>	Straight Hex Size <sup>b</sup>	Adjustable Nut Hex Size	Steel or Gray Iron Torque
mm.	mm	mm	Nm (lb-ft)
M8 x 1	12	12	8 (6)
M10 x 1	14	14	15 (11)
M12 x 1.5	17	17	35 (26)
M14 x 1.5	19	19	45 (33)
M16 x 1.5	22	22	55 (41)
M18 x 1.5	24	24	70 (52)
M22 x 1.5	27	27	100 (74)
M27 x 2	32	32	170 (125)
M30 x 2	36	36	215 (159)
M33 x 2	41	41	260 (192)
M38 x 2	46	46	320 (236)
M42 x 2	50	50	360 (266)
M48 x 2	55	55	420 (310)

Continued on next page

OUT3035.0000421 -19-28MAY09-1/2

T196337—UN—18NOV03

Torque Values

**O-RING STRAIGHT, ADJUSTABLE, AND EXTERNAL HEX PLUG WITH METRIC STUD END FOR HIGH PRESSURE, ABOVE 27 600 KPA (275.8 BAR) (4,000 PSI), TORQUE VALUES—Tolerance is +15 -20% unless otherwise specified**

Thread Size <sup>a</sup>	Straight Hex Size <sup>b</sup>	Adjustable Nut Hex Size	Steel or Gray Iron Torque
mm.	mm	mm	Nm (lb-ft)

<sup>a</sup> Stud end threads are identified as metric by an identification groove in the hex nut next to the O-ring.

<sup>b</sup> Straight hex size applies to fittings only and may not be the same as the corresponding plug of the same thread size.

- |  |   |
|--|---|
| <ol style="list-style-type: none"> <li>1. Inspect fitting and connector sealing surfaces and the O-rings. They must be free of dirt, scratches, nicks, and burrs. O-ring must be free of dirt, cuts, cracks, swelling or flatten condition.</li> <li>2. Back the stud end hex nut off as far as possible. Push backup washer towards the nut to fully expose the turn down section. Washer must fit turned down section and not be too loose</li> <li>3. Lubricate O-rings using a thin film of clean hydraulic oil or as needed, petroleum jelly to hold O-ring in place.</li> </ol> <p>Install O-ring into groove making sure it is seated at the bottom. Excess petroleum jelly will prevent seating of O-ring and cause it to pop out.</p> | <p>To protect an O-ring from threads, wrap electrical tape over the threads. Slide O-ring over the tape into the turned down section. Remove the tape.</p> <ol style="list-style-type: none"> <li>4. Turn fitting into the boss by hand until face of nut or washer squeezes the O-ring into the seat and contacts face of boss. Loosen adjustable fittings no more than one turn for alignment.</li> </ol> <p>Hold connections together while tightening nut to ensure O-ring remains in place.</p> <ol style="list-style-type: none"> <li>5. Tighten fitting or nut to torque value shown. Use a second wrench to hold the fitting in position or to keep hose from twisting while tightening nut.</li> </ol> |
|--|---|

OUT3035,0000421 -19-28MAY09-2/2

### Service Recommendations for Metric Series Four Bolt Flange Fitting

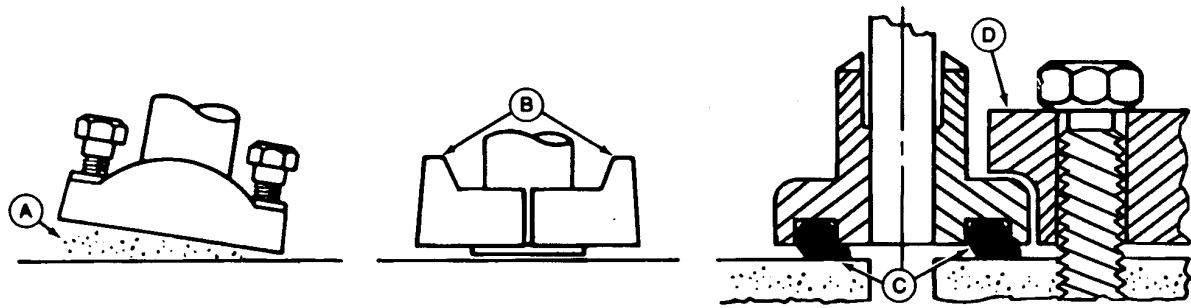

A—Sealing Surface

B—Split Flange

C—Pinched O-Ring

D—Single Piece Flange

1. Clean sealing surfaces (A). Inspect. Scratches cause leaks. Roughness causes seal wear. Out-of-flat causes seal extrusion. If defects cannot be polished out, replace component.
2. Install the correct O-ring (and backup washer if required) into groove using petroleum jelly to hold it in place.
3. Split flange: Loosely assemble split flange (B) halves. Make sure split is centrally located and perpendicular to the port. Hand tighten cap screws to hold parts in place. Do not pinch O-ring (C).
4. Single piece flange (D): Place hydraulic line in center of flange and install four cap screws. Flange must be centrally located on port. Hand tighten cap screws to hold flange in place. Do not pinch O-ring.
5. After components are properly positioned and cap screws are hand tightened, tighten one cap screw, then tighten the diagonally opposite cap screw. Tighten two remaining cap screws. Tighten all cap screws as specified in the chart below.

DO NOT use air wrenches. DO NOT tighten one cap screw fully before tightening the others. DO NOT over tighten.

<sup>a</sup> TORQUE CHART		
<sup>b</sup> Thread	N·m	lb·ft
M6	12	9
M8	30	22
M10	57	42
M12	95	70
M14	157	116
M16	217	160
M18	334	246
M20	421	318

<sup>a</sup>Tolerance  $\pm 10\%$ . The torques given are enough for the given size connection with the recommended working pressure. Increasing cap screw torque beyond these amounts will result in flange and cap screw bending and connection failures.

<sup>b</sup>Metric standard thread.

T6890BB—UN—01MAR90

04T,90,K175 -19-29SEP99-1/1

### Service Recommendations For Inch Series Four Bolt Flange Fittings

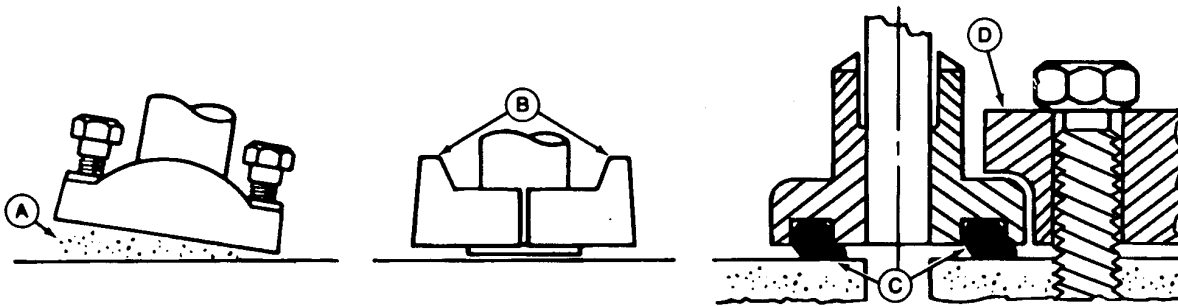

T6890BB—UN—01MAR90

**A—Sealing Surface**

**B—Split Flange**

**C—Pinched O-Ring**

**D—Single Piece Flange**

1. Clean sealing surfaces (A). Inspect. Scratches cause leaks. Roughness causes seal wear. Out-of-flat causes seal extrusion. If defects cannot be polished out, replace component.
2. Install O-ring (and backup washer if required) into groove using petroleum jelly to hold it in place.
3. Split flange: Loosely assemble split flange (B) halves. Make sure split is centrally located and perpendicular to port. Hand tighten cap screws to hold parts in place. Do not pinch O-ring (C).
4. Single piece flange (D): Place hydraulic line in center of flange and install cap screws. Flange must be centrally located on port. Hand tighten cap screws to hold flange in place. Do not pinch O-ring.
5. Tighten one cap screw, then tighten the diagonally opposite cap screw. Tighten two remaining cap screws. Tighten all cap screws as specified in the chart below.

DO NOT use air wrenches. DO NOT tighten one cap screw fully before tightening the others. DO NOT over tighten.

TORQUE CHART					
Nominal Flange Size	Cap Screw Size	N-m		lb-ft	
		Min	Max	Min	Max
1/2	5/16-18 UNC	20	31	15	23
3/4	3/8-16 UNC	28	54	21	40
1	3/8-16 UNC	37	54	27	40
1-1/4	7/16-14 UNC	47	85	35	63
1-1/2	1/2-13 UNC	62	131	46	97
2	1/2-13 UNC	73	131	54	97
2-1/2	1/2-13 UNC	107	131	79	97
3	5/8-11 UNC	158	264	117	195
3-1/2	5/8-11 UNC	158	264	117	195
4	5/8-11 UNC	158	264	117	195
5	5/8-11 UNC	158	264	117	195

04T,90,K174 -19-01AUG94-1/1

**Inch Series Four Bolt Flange Fitting For High Pressure Service Recommendations**

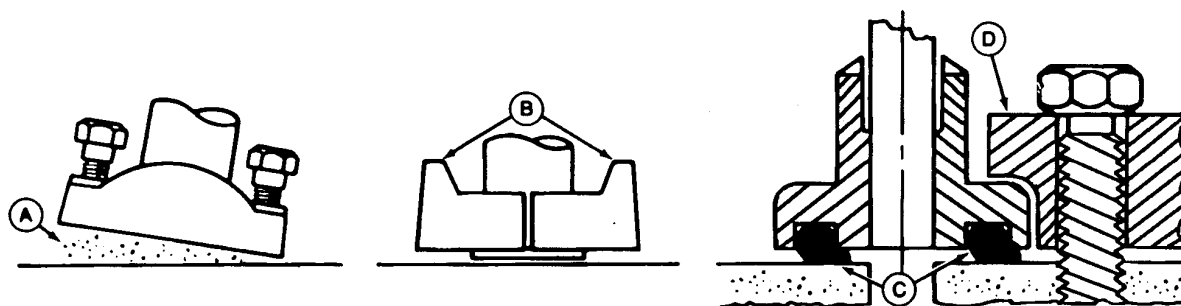

A—Sealing Surface

B—Split Flange

C—Pinched O-Ring

D—Single Piece Flange

**INCH SERIES FOUR BOLT FLANGE FITTING FOR 41 400 kPa (414 bar) (6000 psi) PRESSURE SERIES TORQUE VALUES—Tolerance is ± 10% unless otherwise specified**

Nominal Flange Size	Cap Screw Size <sup>a</sup>	Min—Max Torque
in.	in.	Nm (lb-ft) <sup>b</sup>
1/2	5/16-18 UNC	20—31 (15—23)
3/4	3/8-16 UNC	34—54 (25—40)
1	7/16-14 UNC	57—85 (42—63)
1-1/4	1/2-13 UNC	85—131 (63—97)
1-1/2	5/8-11 UNC	159—264 (117—195)
2	3/4-10 UNC	271—468 (200—345)

<sup>a</sup> JDM A17D, SAE Grade 5 or better cap screws with plated hardware. Lock washers are permissible but not recommended.

<sup>b</sup> Minimum torques given are enough for the given size connection with the recommended working pressure. Torques can be increased to the maximum shown for each cap screw size if desired. Increasing cap screw torque beyond the maximum will result in flange and cap screw bending and connection failures.

1. Clean sealing surfaces (A). Inspect. Scratches, nicks, and burrs cause leaks. Roughness causes O-ring wear. Out-of-flat causes O-ring extrusion.

If imperfection cannot be polished out, replace component.

2. Install the O-ring (and backup ring, if used) into groove. Use petroleum jelly to hold it in place.
- IMPORTANT: DO NOT use air wrenches. DO NOT tighten one cap screw fully before tightening the others. DO NOT over tighten.**
3. Split flange: Loosely assemble split flange (B) halves. Make sure split is centrally located and perpendicular to port. Hand tighten cap screws to hold flange halves and line in place. Do not pinch O-ring (C).
- Single piece flange (D): Make sure flange is centrally located on port and line is centered in flange. Install the cap screws. Hand tighten cap screws to hold flange and line in place. Do not pinch O-ring.
4. Tighten one cap screw and then the diagonally opposite cap screw. Tighten the two remaining cap screws. Tighten cap screws within the specified torque values.

T6890BB—UN—01MAR90

OUT3035,0000422 -19-05MAR09-1/1

### Service Recommendations For Non-Restricted Banjo (Adjustable) Fittings

1. Inspect all fitting sealing surfaces. They must be free of dirt and defects.
2. Inspect O-ring (A). It must be free of damage or defects.
3. Inspect sealing ring (B) for damage or defects.
4. Hold body in desired position while tightening stud by hand.
5. Tighten stud (C) to torque value shown on the chart. Do not allow body to twist when tightening stud.

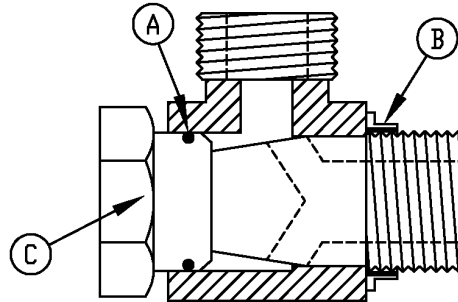

**NOTE:** The L in the Tube Fitting OD Size column indicates "light" designed fitting and the S indicates "heavy" designed fitting.

Tube Fitting O.D. Size	Metric Thread	Torque Value	
		N·m	lb-ft
6 L	M 10 x 1	30	22
8 L	M 12 x 1.5	40	30
10 L	M 14 x 1.5	60	44
12 L	M 16 x 1.5	100	74
15 L	M 18 x 1.5	130	96
18 L	M 22 x 1.5	160	118
22 L	M 26 x 1.5	250	184
28 L	M 33 x 2	400	295
35 L	M 42 x 2	600	443
42 L	M48 x 2	800	590
6 S	M 12 x 1.5	40	30
8 S	M 14 x 1.5	60	44
10 S	M 16 x 1.5	100	74
12 S	M 18 x 1.5	130	96
14 S	M 20 x 1.5	160	118
16 S	M 22 x 1.5	160	118
20 S	M 27 x 2	250	184
25 S	M 33 x 2	400	295
30 S	M 42 x 2	600	443
38 S	M 48 x 2	800	590

T113948

Tube Fitting O.D. Size	Inch Size	Torque Value	
		N·m	lb-ft
6 L	1/8	25	18
8 L	1/4	50	37
10 L	1/4	50	37
12 L	3/8	90	66
15 L	1/2	130	96
18 L	1/2	150	111
22 L	3/4	250	184
28 L	1	400	295
35 L	1-1/4	600	443
42 L	1-1/2	800	590
6 S	1/4	50	37
8 S	1/4	50	37
10 S	3/8	90	66
12 S	3/8	100	74
14 S	1/2	130	96
16 S	1/2	150	111
20 S	3/4	250	184
25 S	1	400	295
30 S	1-1/4	600	443
38 S	1-1/2	800	590

T113948—UN—06MAR98

CED,OUO1002,562 -19-09MAR98-1/1

### Service Recommendations For O-Ring Boss Fittings With Shoulder

1. Inspect component seal boss seat for dirt or defects.
2. Inspect EOlastic seal (A) for damage. Replace seal or fitting as necessary.  
  
To replace seal, put electrical tape over threads to protect seal. Slide seal over tape and into seal groove of fitting. Remove tape.
3. Tighten fitting to torque value shown on chart.

**IMPORTANT: Do not allow hoses to twist when tightening fittings.**

*NOTE: The L in the Tube Fitting OD Size column indicates "light" designed fitting and the S indicates "heavy" designed fitting.*

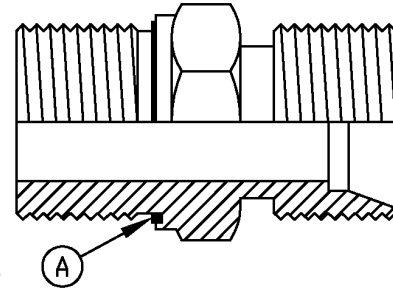

T113957

T113957—UN—06MAR98

Tube Fitting O.D. Size	Torque Value		
	Metric Thread	N·m	lb·ft
6 L	M 10 x 1	20	15
8 L	M 12 x 1.5	30	22
10 L	M 14 x 1.5	45	33
12 L	M 16 x 1.5	60	44
15 L	M 18 x 1.5	80	59
18 L	M 22 x 1.5	130	96
22 L	M 26 x 1.5	190	140
28 L	M 33 x 2	300	221
35 L	M 42 x 2	600	443
42 L	M48 x 2	800	590
6 S	M 12 x 1.5	40	30
8 S	M 14 x 1.5	60	44
10 S	M 16 x 1.5	80	59
12 S	M 18 x 1.5	110	81
14 S	M 20 x 1.5	140	103
16 S	M 22 x 1.5	170	125
20 S	M 27 x 2	250	184
25 S	M 33 x 2	450	332
30 S	M 42 x 2	600	443
38 S	M 48 x 2	800	590

Tube Fitting O.D. Size	Torque Value		
	Inch Size	N·m	lb·ft
6 L	1/8	20	15
8 L	1/4	40	30
10 L	1/4	40	30
12 L	3/8	80	59
15 L	1/2	140	103
18 L	1/2	100	74
22 L	3/4	180	133
28 L	1	300	221
35 L	1-1/4	600	443
42 L	1-1/2	800	590
6 S	1/4	50	37
8 S	1/4	50	37
10 S	3/8	90	66
12 S	3/8	90	66
14 S	1/2	160	118
16 S	1/2	140	103
20 S	3/4	250	184
25 S	1	400	295
30 S	1-1/4	650	479
38 S	1-1/2	800	590

*Torque Values*

<b>Hex Socket Head Plugs Only</b>		
<b>Torque Value</b>		
<b>Thread Size</b>	<b>N·m</b>	<b>lb-ft</b>
M 10 x 1	13	10
M 12 x 1.5	30	22
M 14 x 1.5	40	30
M 16 x 1.5	60	44
M 18 x 1.5	70	52
M 20 x 1.5	90	66
M 22 x 1.5	100	74
M 26 x 1.5	120	89
M 27 x 2	150	111
M 33 x 2	250	184
M 42 x 2	400	295
M 48 x 2	500	369
1/8	15	11
1/4	33	24
3/8	70	52
1/2	90	66
3/4	150	111
1	220	162
1-1/4	600	443
1-1/2	800	590

CED,OUO1002,563 -19-09MAR98-2/2

## Metric 24° O-Ring Seal DIN 20078 Service Recommendations

METRIC 24° O-RING SEAL DIN 20078 TORQUE VALUES			
Fitting Tube OD Size	Heavy Fitting Size	Light Fitting Size	Torque
mm	mm	mm	Turns
6	—	M12 x 1.5	Hand tighten so O-ring contacts seat plus an additional 1/4—1/3 turn using a wrench
8	M16 x 1.5	M14 x 1.5	
10	M18 x 1.5	M16 x 1.5	
12	M20 x 1.5	M18 x 1.5	
14	M22 x 1.5	—	
15	—	M22 x 1.5	
16	M24 x 1.5	—	
18	—	M26 x 1.5	
20	M30 x 2	—	
22	—	M30 x 2	
25	M36 x 2	—	
28	—	M36 x 2	
30	M42 x 2	—	
35	—	M45 x 2	
38	M52 x 2	—	

**NOTE:** These fittings are also referred to as EO and EO-2 Bite Type or Ermeto style fittings.

**IMPORTANT:** In this style of fittings, there are “heavy” and “light” designs. Usually “heavy” is used for pressure lines and “light” for return lines.

Some “heavy” and “light” sizes can be threaded together but do not seal properly. Be sure not to mix “heavy” and “light” fittings.

1. Inspect the fitting sealing surfaces. They must be free of dirt scratches, nicks, and burrs.
2. Inspect the O-ring. It must be free dirt, cuts, cracks, swelling or flatten condition.
3. Lubricate O-rings using a thin film of clean hydraulic oil.
4. Align an adjustable fitting with the tube.

5. Tighten nut (A) hand tight so O-ring contacts seat and then an additional 1/4—1/3 turn using a wrench.

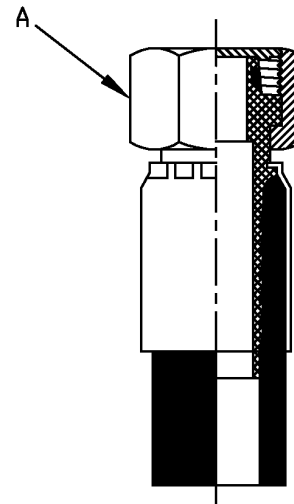
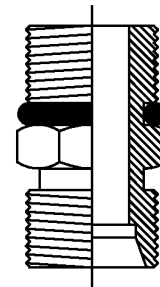

T113889

Hold connections together while tightening nut to ensure proper seal.

T113889 —UN—06MAR98

CED,OUO1002,517 -19-14JAN04-1/1

*Torque Values*

## Section 01 Tracks

### Contents

	Page
<b>Group 0130—Track System</b>	
Rock Guards and Chain Guides	
Remove and Install.....	01-0130-1
Carrier Roller Remove and Install.....	01-0130-2
Carrier Roller Disassemble and Assemble.....	01-0130-5
Metal Face Seals Inspection .....	01-0130-6
Track Roller Remove and Install .....	01-0130-7
Track Roller Disassemble and Assemble.....	01-0130-8
Track Roller Leakage Test.....	01-0130-9
Track Shoe Remove and Install .....	01-0130-9
Sealed Track Chain Removal.....	01-0130-11
Sealed Track Chain Disassemble and Assemble.....	01-0130-15
Sealed Track Chain Installation.....	01-0130-15
Lubricated Track Chain (Saw Tooth Master Split Link) Remove and Install .....	01-0130-17
Lubricated Track Chain Disassembly (Turn Bushings and Lubricate Chain).....	01-0130-20
Lubricated Track Chain Assembly (Turn Bushings and Lubricate Chain).....	01-0130-22
Lubricated Track Chain Disassemble and Assemble (Turn Pins and Not Lubricate).....	01-0130-29
Front Idler Remove and Install .....	01-0130-33
Front Idler Disassemble, Inspect, and Assemble.....	01-0130-34
Front Idler Adjustment .....	01-0130-36
Front Idler Oil Level Check.....	01-0130-37
Track Tension Adjuster Remove and Disassemble .....	01-0130-38
Track Tension Adjuster Assemble and Install .....	01-0130-40
Track Idler Recoil Spring Remove and Install .....	01-0130-41
Track Idler Recoil Spring Disassemble and Assemble .....	01-0130-42
Sprocket Remove and Install.....	01-0130-46
Track Frame Remove and Install .....	01-0130-47
Track Frame Disassemble and Assemble.....	01-0130-47
Frame Wear Strips Remove and Install .....	01-0130-50

*Contents*

**Rock Guards and Chain Guides Remove and Install**

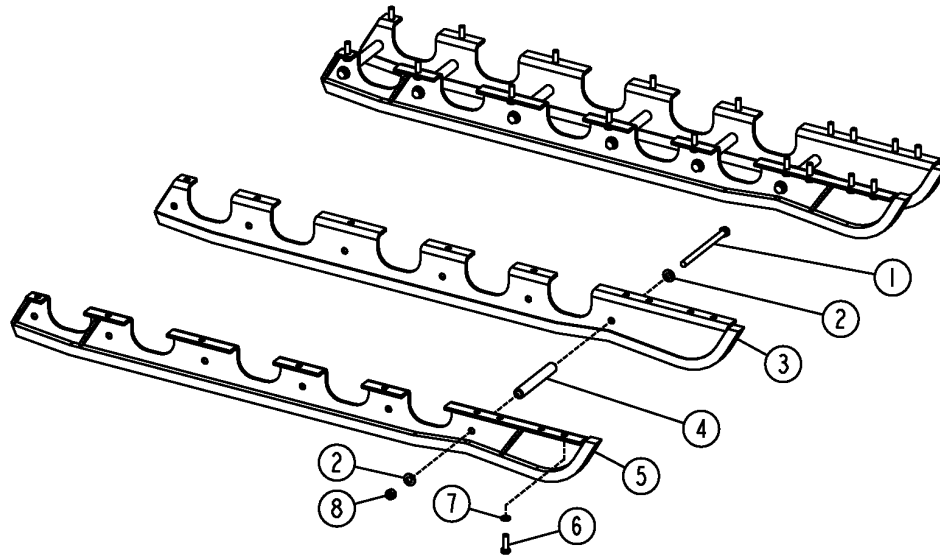

T118572

450J Standard Rock Guards Shown

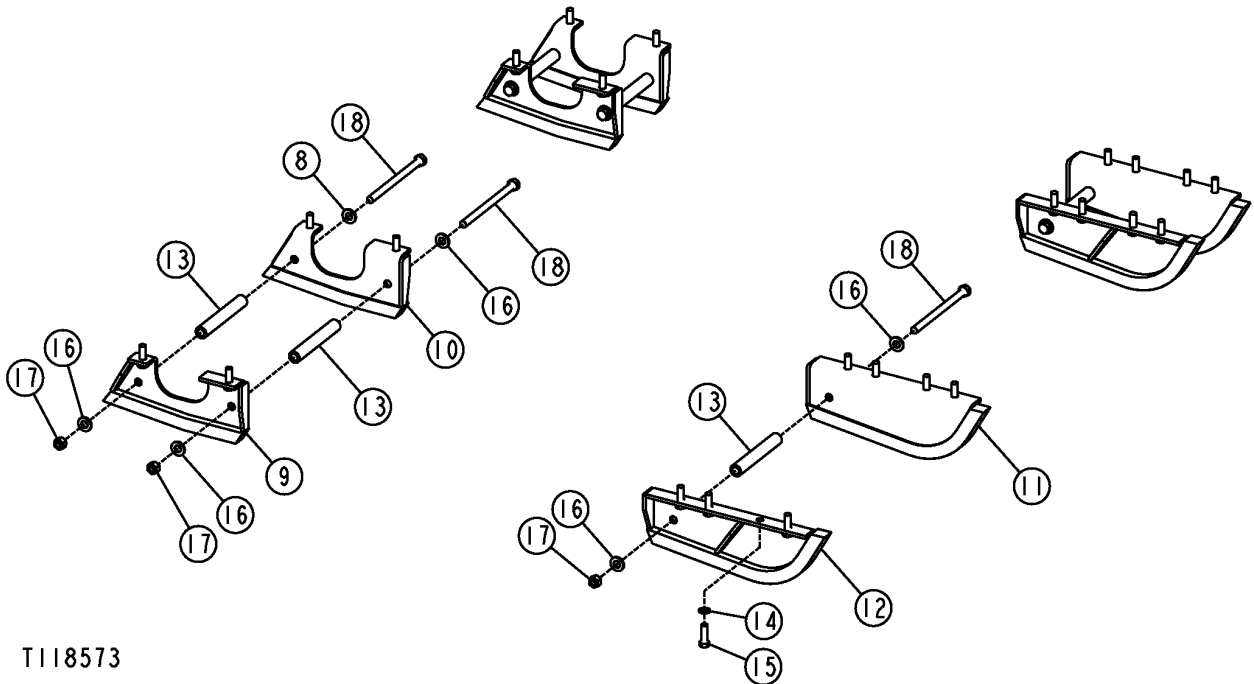

T118573

450J Standard Chain Guides Shown

- |  |   |                         |                        |
|--|---|-------------------------|------------------------|
| 1— Cap Screw—450J (6 used);<br>550J, 650J, and 605C (7 used)   | 6— Cap Screw—450J (18 used);<br>550J, 650J, and 605C (20<br>used) | 11— Guide               | 16— Washer (6 used)    |
| 2— Washer—450J (12 used);<br>550J, 650J, and 605C (14<br>used) | 7— Washer—450J (18 used);<br>550J, 650J, and 605C (20<br>used)    | 12— Guide               | 17— Nut (3 used)       |
| 3— Rock Guard Outside  | 8— Nut (6 used)   | 13— Spacer (3 used)     | 18— Cap Screw (3 used) |
| 4— Spacer—450J (6 used); 550J,<br>650J, and 605C (7 used)      | 9— Guide  | 14— Washer (12 used)    |                        |
| 5— Rock Guard Inside   | 10— Guide   | 15— Cap Screw (12 used) |                        |

Continued on next page

CED,OUTX547,66 -19-19JAN06-1/2

T118572 —UN—01DEC98

T118573 —UN—01DEC98

## Track System

**CAUTION:** Rock Guard is heavy and can cause injury if not moved properly. Use adequate lifting device to move rock guard.

### Rock Guard—Specification

Rock Guard—Approximate Weight.....	100 kg
	220 lb

1. Use a chain and hoist when removing rock guards. Inspect parts, replace if necessary.
2. Tighten rock guard cap screws.

### Rock Guard—Specification

Rock Guard-to-Track	
Frame Cap	
Screws—Torque.....	203 N·m
	150 lb·ft

Rock Guard-to-Spacer-to-Rock Guard Cap	
Screws—Torque.....	278 N·m
	205 lb·ft

3. Tighten chain guide cap screws.

### Chain Guides—Specification

Chain Guides-to-Track	
Frame Cap	
Screws—Torque.....	203 N·m
	150 lb·ft
Chain Guide-to-Spacer-to-Rock Guard Cap	
Screws—Torque.....	278 N·m
	205 lb·ft

CED,OUTX547,66 -19-19JAN06-2/2

## Carrier Roller Remove and Install

**CAUTION:** Grease for track adjuster cylinder is under high pressure. Never remove grease fitting to release the grease. If grease does not escape immediately from vent hole when fitting has been loosened, slowly drive unit in forward and reverse until grease escapes. **DO NOT** disassemble parts unless you know the correct procedure and have correct tools. (See your authorized dealer.)

If an accident occurs, see a doctor immediately. Any fluid injected into the skin must be surgically removed within a few hours or gangrene may result. Doctors unfamiliar with this type of injury may call the Deere & Company Medical Department in Moline, Illinois, or other knowledgeable medical source.

1. Remove access plug (A).

**A**—Access Plug

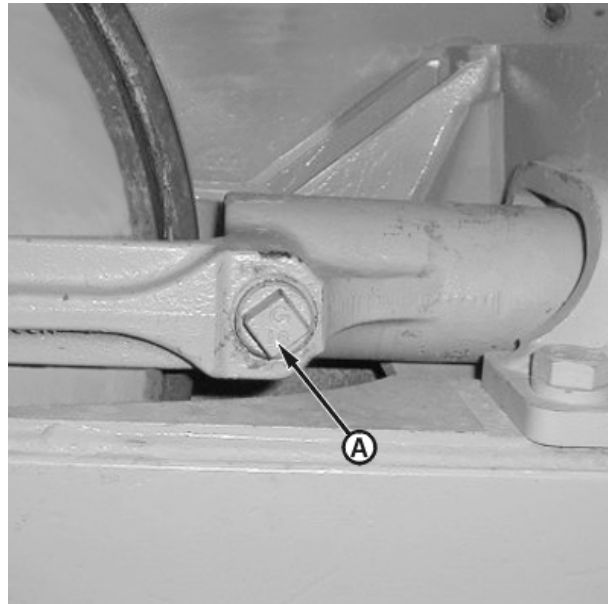

T118011B—UN—11NOV98

Continued on next page

TE14778,0000043 -19-04MAY06-1/3

## Track System

2. To increase track sag:
  - a. Loosen fitting (C) (not the grease fitting), one to two turns counterclockwise to release grease through vent hole (D).
  - b. Tighten fitting.
  - c. Move machine forward and reverse to allow track adjuster cylinder to fully adjust.
3. Install plug.

**⚠ CAUTION: Securely support track before attempting service procedure to prevent accidental lowering of track.**

4. Use a jack to raise track link enough to permit carrier roller removal. Secure track.

B—Grease Fitting  
C—Fitting

D—Vent Hole

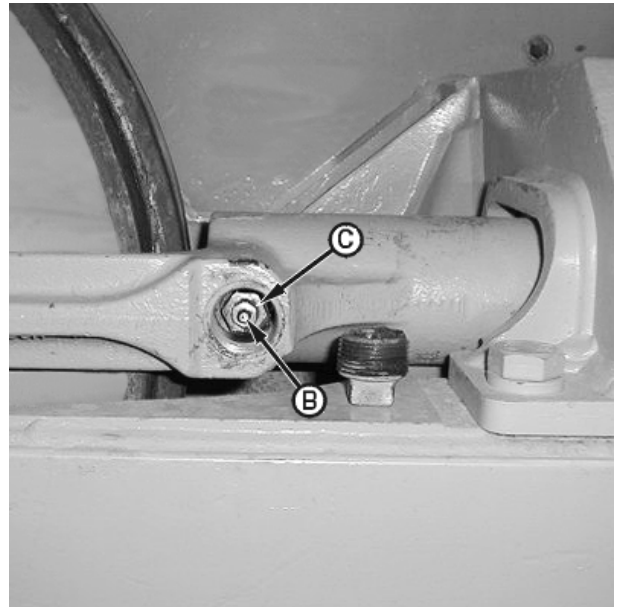

T118012B—UN—01DEC98

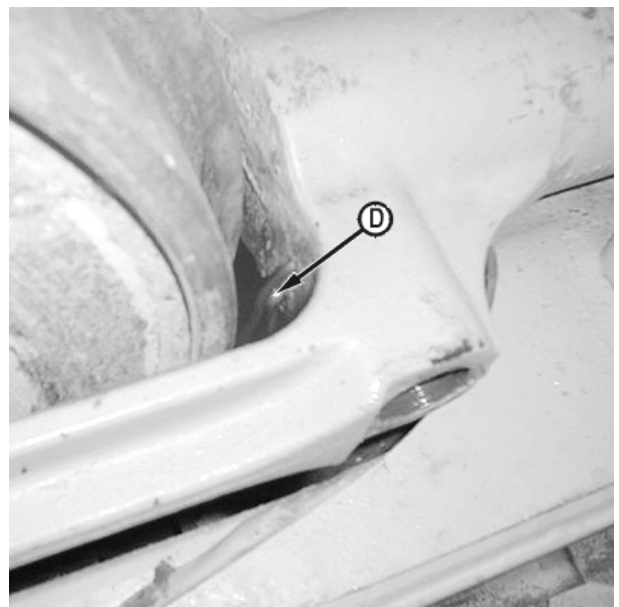

T118013B—UN—11NOV98

Continued on next page

TE14778,0000043 -19-04MAY06-2/3

## Track System

5. Remove cap screws (1) and carrier roller assembly.
6. Measure carrier roller tread diameter. See 450D, 450E, 450G, 450H, 450J, 455D, 455E, 455G, 550A, 550B, 550G, 550H, 550J, 555A, and 555B Carrier Roller Tread Diameter—Clamp-On Design. (SP326 Undercarriage Appraisal Manual.)  
  
Also see 555G, 605C, 650G, 650H, and 650J Carrier Roller Tread Diameter—Clamp-On Design. (SP326 Undercarriage Appraisal Manual.)
7. Repair or replace parts as necessary. See Carrier Roller Disassemble and Assemble. (Group 0130.)
8. Install carrier roller and tighten cap screws (1) to specification.

### Carrier Roller—Specification

Bracket-to-Frame Cap  
Screw—Torque.....620 N·m  
(460 lb-ft)

9. Adjust track sag. See Adjust Track Sag. (Operators Manual.)

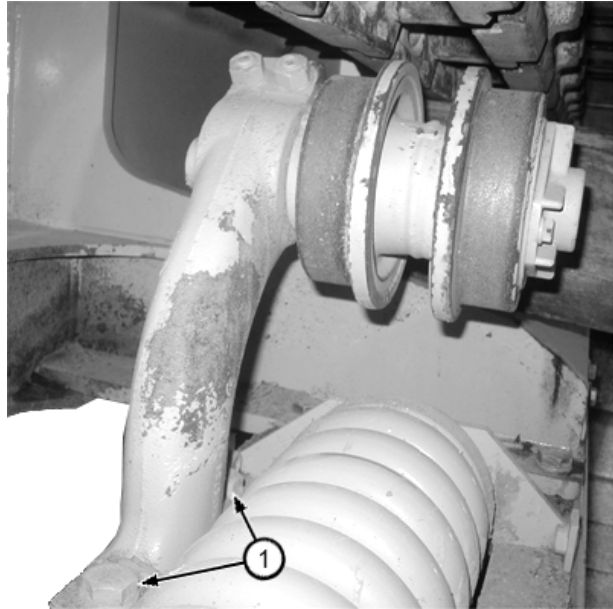

1— Cap Screw (2 used)

T198433A —UN—12MAR04

TE14778,0000043 -19-04MAY06-3/3

**Carrier Roller Disassemble and Assemble**

1. Remove bracket from carrier roller (if not removed).
2. Remove cap screws (8) and cover (9).
3. Drain oil from housing.
4. Remove cap screws (10) and retainer plate (7) from shaft (11).
5. Press outer bearing cone (F) and shaft (11) out of roller shell (2) using a press.
6. Press inner bearing cone (12) from shaft (11). Bearing is a press fit.

**IMPORTANT: Metal face seals can be reused if they are not worn or damaged. A used seal must be kept together as a set because of wear patterns on seal ring face.**

7. Remove snap ring (4), seal retainer (3) and metal face seals (5). Keep seal rings together as a matched set with faces together to protect lapped surfaces. Inspect metal face seal. See Metal Face Seals Inspection. (Group 0130.)
8. Remove bearing cups (1). Inspect roller shell for grooved, burred or galled condition.
9. Replace parts as necessary.
10. Install bearing cups (1) into roller shell, install tight against shoulders.
11. Install inner bearing cone (12) tight against shoulder on shaft. Bearing is a press fit.
12. Install shaft (11) in roller shell.
13. Press outer bearing cone (6) on shaft so bearing is even with end of the shaft.
14. Install retainer plate (7) and cap screws (10). Tighten cap screws to specification.

**Carrier Roller—Specification**

Carrier Roller	
Retainer Plate Cap	
Screws—Torque.....	47 N·m (35 lb·ft)

**IMPORTANT: O-ring and seat surfaces must be clean, dry and oil free so O-rings do not slip when roller is turning.**

15. Thoroughly clean the O-rings and seat surfaces in roller, seal retainer and seal rings using a volatile, non-petroleum base solvent and lint-free tissues.
16. Install one half of metal face seal (5) into seal retainer (3). Install other half of seal into roller shell (2).



Disassembled Carrier Roller

- |                         |                        |
|-------------------------|------------------------|
| 1— Bearing Cup (2 used) | 8— Cap Screw (3 used)  |
| 2— Roller Shell         | 9— Cover               |
| 3— Seal Retainer        | 10— Cap Screw (2 used) |
| 4— Snap Ring            | 11— Shaft              |
| 5— Metal Face Seal      | 12— Bearing Cone       |
| 6— Bearing Cone         | 13— O-Ring             |
| 7— Retainer Plate       |                        |

17. Apply equal pressure with the fingers at four equally spaced points on seal ring face. O-ring and seal ring should seat squarely in bore.

*NOTE: A volatile, non-petroleum base solvent or talcum powder may be used as a lubricant.*

18. Wipe both metal seal ring faces dry with a lint-free tissue.
19. Apply a thin film of oil, as used in the roller, to the shiny sealing area on both metal seal rings.
20. Install seal retainer (3) and snap ring (4) on roller shaft.
21. Fill roller with clean oil. See Adding Oil To The Roller. (Operator's Manual.)
22. Install cover (9) and cap screws (8). Tighten cap screws to specification.

**Carrier Roller—Specification**

Carrier Roller Cover Cap	
Screws—Torque.....	47 N·m (35 lb·ft)

CED, TX03399, 5938 -19-16DEC09-1/1

T198436A—UN—12MAR04

### Metal Face Seals Inspection

- Inspect for the following conditions to determine if seals can be reused:
  - The narrow, highly polished sealing area (E) must be in the outer half of seal ring face (D).
  - Sealing area must be uniform and concentric with the ID and OD of seal ring (A).
  - Sealing area must not be chipped, nicked, or scratched.

A—Seal Ring  
 B—Worn Area (shaded area)  
 C—Seal Ring Face  
 D—Outer Half of Seal Ring Face  
 E—Sealing Area (dark line)

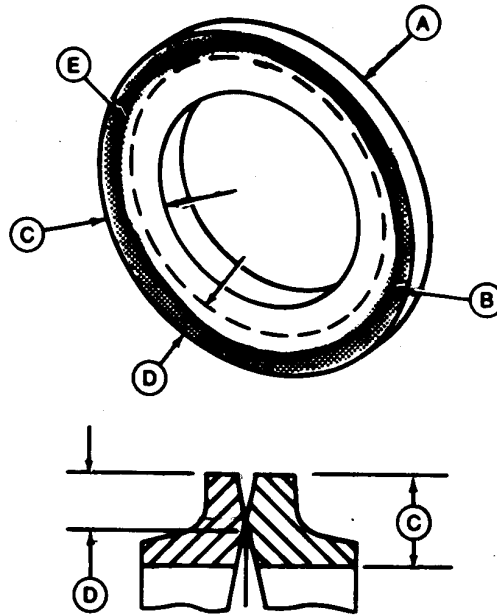

T85079—UN—24AUG93

CED,TX03399,5062 -19-24MAR08-1/3

- Illustration shows examples of worn seal rings (A).
  - I—Sealing area (D) is in inner half of seal ring face (C).
  - II—Sealing area (D) not concentric with ID and OD of seal ring.

A—Seal Ring  
 B—Worn Area (shaded area)  
 C—Inner Half of Seal Ring Face  
 D—Sealing Area (dark line)

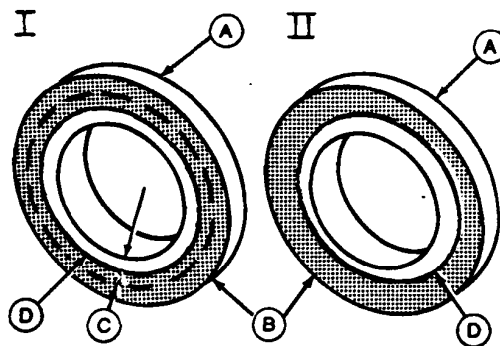

T85080—UN—05DEC96

CED,TX03399,5062 -19-24MAR08-2/3

- Clean reusable seals by removing all foreign material from seal rings, except seal face (A), using a scraper or a stiff bristled fiber brush.
- Wash seal rings and O-rings using a volatile, non-petroleum base solvent to remove all oil. Thoroughly dry parts using a lint-free tissue. Apply a thin film of oil to seal ring face. Put face of seal rings together and hold using tape.

A—Seal Face

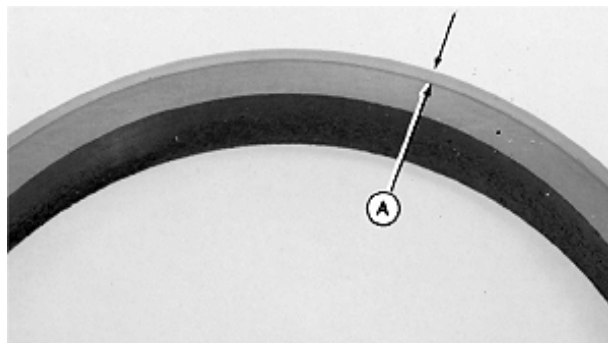

T82840—UN—23FEB89

CED,TX03399,5062 -19-24MAR08-3/3

### Track Roller Remove and Install

1. Track rollers can be removed without disconnecting track. Release track tension to provide sufficient clearance. See Adjust Track Sag. (Operator's Manual.)
2. If machine is equipped with rock guards, remove outer rock guard and loosen inner rock guard cap screws.  
  
If machine is equipped with chain guides, remove rear chain guide.

**⚠ CAUTION: Prevent possible injury from unexpected machine movement. Put shop stands under frame to support machine while removing lower track roller.**

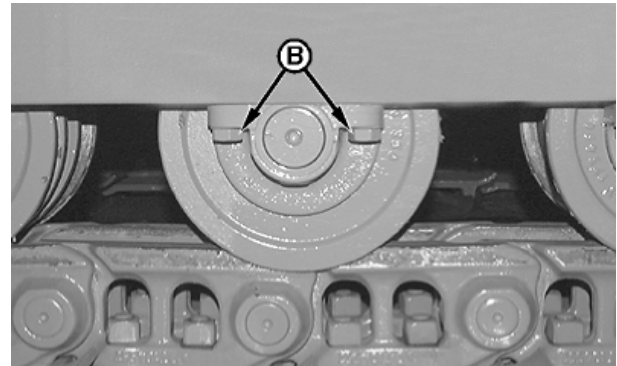

T113330—UN—12FEB98

**B—Cap Screw**

#### Specification

Machine—Weight	
(approximate).....	8391 kg 18 500 lb

Also see 555G, 605C, 650G, 650H, and 650J Track Roller Tread Diameter. (SP326 Undercarriage Appraisal Manual.)

3. Raise crawler to provide a clearance for roller removal. Put shop stands under machine.
4. Remove four roller bracket cap screws (B) to remove roller assembly.
5. Measure track roller tread diameter. See 450D, 450E, 450G, 450H, 450J, 455D, 455E, 455G, 550A, 550B, 550G, 550H, 550J, 555A, and 555B Track Roller Tread Diameter. (SP326 Undercarriage Appraisal Manual.)
6. Repair or replace parts as necessary. See Track Roller Disassemble and Assemble. (Group 0130.)
7. Install roller assembly and tighten cap screws (B).

#### Track Roller—Specification

Roller Bracket-to-Track	
Frame Cap	
Screw—Torque.....	203 N·m 150 lb-ft

CED.OUTX547,73 -19-24MAR08-1/1

## Track Roller Disassemble and Assemble

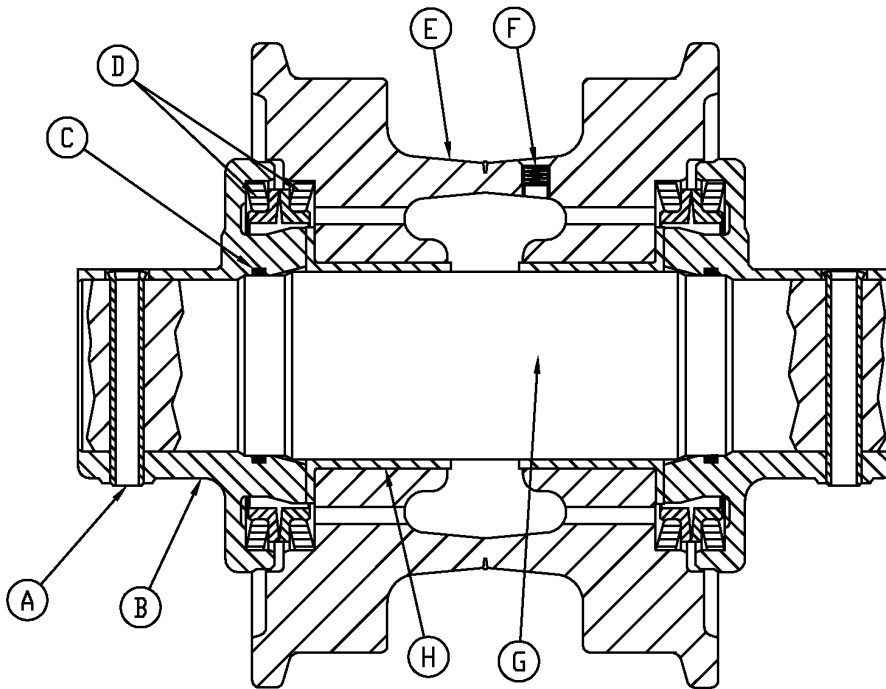

T113331 —UN—10FEB98

T113331

A—Spring Pin (2 used)  
B—Bracket (2 used)

C—O-Ring (2 used)  
D—Metal Face Seal (2 used)

E—Roller  
F—Plug

G—Shaft  
H—Bushing (2 used)

*NOTE: Spring pins (A) are tapered on top (flat of bracket). Drive pin out from the bottom.*

1. Remove parts (A—D) from both ends of roller.

*NOTE: Bracket, shaft, bushings and roller are serviced as an assembly only.*

*Avoid damage to metal face seals. Metal face seals can be reused if they are not worn or damaged. A used seal must be kept together as a set because of wear patterns on seal ring face.*

2. Remove shaft (G).

3. Inspect shaft bushings, brackets and roller for wear or damage. Replace as an assembly.

4. Lubricate both bushings with oil and install shaft (G).

5. Remove grease from sealing surfaces in roller and roller brackets.

6. Install new metal face seals (D) (if necessary). See Metal Face Seals Inspection. (Group 0130.)  
Install half of seal into roller and other half into bracket.

7. Install O-rings (C) in both brackets.

8. Install brackets (B).

9. Install new spring pins (A) in through top (flat of bracket). Tapered end of pin should be flush with top of bracket.

10. Fill roller with clean oil. See Adding Oil To The Roller. (Operator's Manual.)

CED,OUTX547,74 -19-24MAR08-1/1

### Track Roller Leakage Test

1. Remove plug from track roller.
2. Fill roller with clean oil. See Adding Oil To The Roller. (Operators Manual.)
3. Turn roller several times to seal metal face seals.
4. Assemble parts (1—6) as shown.
5. Pressurize roller using air to specification and close valve (5).

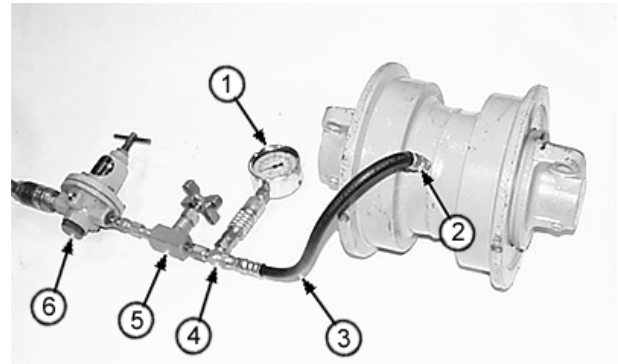

T118645B —UN—30NOV98

#### Track Roller—Specification

Track Roller Leakage  
 Test—Pressure..... 97—138 kPa  
 (0.97—1.38 bar)  
 (14—20 psi)

6. Track roller must maintain air pressure for two minutes. Oil must not leak past metal seals or O-ring. If oil leaks past seals, repair as necessary.
7. Apply pipe sealant to threads of plug.
8. Install and tighten plug.

- 1— Pressure Gauge 689 kPa (6.89 bar) (0—100 psi)
- 2— JT05487 Fitting (1/8 M NPT x 7/16 -20 M 37°)
- 3— Pressure Hose (7/16 -20 F 37° x 7/16 -20 F 37°)+
- 4— JT03001 Tee Fitting (7/16 -20 M 37° x 7/16 -20 F 37°)
- 5— JT03087 Snubber Valve
- 6— Regulator

CED.OUTX547.76 -19-01JUN04-1/1

### Track Shoe Remove and Install

**CAUTION:** Swamp shoe is heavy and can cause injury if not moved properly. Use adequate lifting device to move swamp shoe.

#### Track Shoe—Specification

Swamp Shoe—Approximate Weight..... 25 kg  
 54 lb

*NOTE: For lubricated chain, cap screws hold a shoe and split master link together.*

1. Measure grouser height of several track shoes to find an average using a depth gauge such as the JT05521 200 mm Ruler, JT05534 Right Angle Attachment and D05231ST 300 mm Ruler from JT05518 or JT05523 Undercarriage Inspection Service Tool Kit.  
 See 450D, 450E, 450G, 450H, 450J, 455D, 455E, 455G, 550A, 550B, 550G, 550H, 550J, 555A, and 555B Single Bar Grouser Height. (SP326 Undercarriage Appraisal Manual.)  
 See 450D, 450E, 450G, 450H, 450J, 455D, 455E, 455G, 550A, 550B, 550G, 550H, 550J, 555A, and 555B Two Bar Grouser Height. (SP326 Undercarriage Appraisal Manual.)

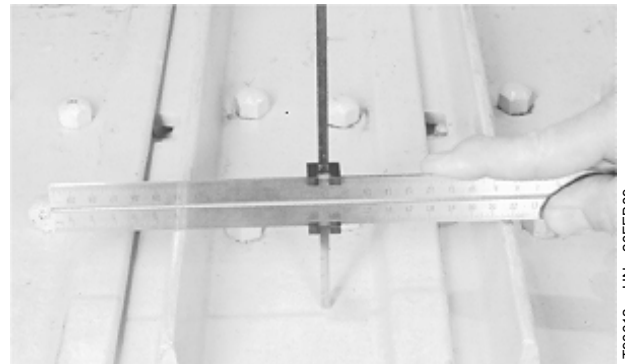

T93612 —UN—23FEB89

See 450D, 450E, 450G, 450H, 450J, 455D, 455E, 455G, 550A, 550B, 550G, 550H, 550J, 555A, and 555B Three Bar Grouser Height. (SP326 Undercarriage Appraisal Manual.)

See 555G, 605C, 650G, 650H, and 650J Single Bar Grouser Height. (SP326 Undercarriage Appraisal Manual.)

See 555G, 605C, 650G, 650H, and 650J Two Bar Grouser Height. (SP326 Undercarriage Appraisal Manual.)

Continued on next page

CED.OUTX547.78 -19-04DEC07-1/3



### Sealed Track Chain Removal

1. Rotate track to position, the master pin on the front idler at approximately a twelve o'clock position to clear C-frame.

*NOTE: Master pin is identified by drill point in end of pin.*

**CAUTION:** Make sure track is off floor before rotating.

2. Remove track shoes on each side of master pin. See Track Shoe Remove and Install. (Group 0130.)

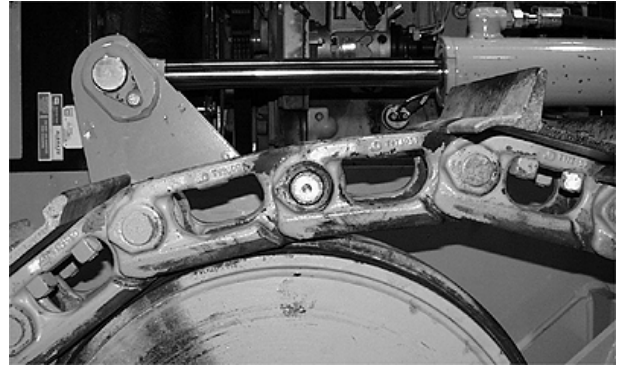

T118662B —UN—30NOV98

CED.OUTX547,83 -19-16DEC09-1/6

**CAUTION:** Grease for track adjuster cylinder is under high pressure. Never remove special high pressure fitting (2) to release the grease.

If grease does not escape immediately from vent hole when relief or check valve is open, slowly drive machine forward and reverse until grease escapes; then close relief or check valve.

3. Release track tension:
  - a. Turn check valve (1) one to three turns counterclockwise to release grease through vent hole.
  - b. DO NOT loosen special grease fitting (2).
  - c. Tighten valve.

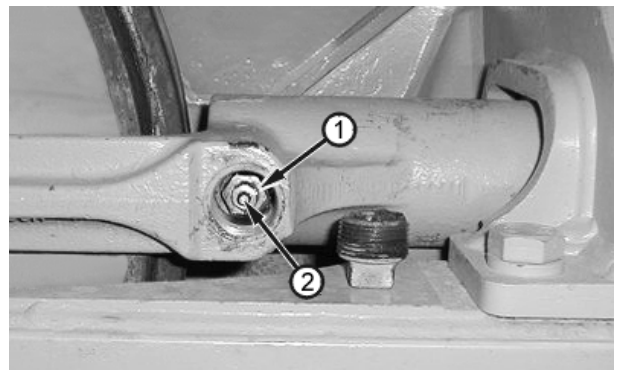

T118012C —UN—23NOV98

1— Check Valve

2— Grease Fitting

CED.OUTX547,83 -19-16DEC09-2/6

**IMPORTANT:** Do not remove the track master pin with a hammer. This will enlarge the link pin bore requiring installation of a new track link.

4. Remove master pin from track link using master pin pusher. Install aligning adapter (A) into master pin pusher C-frame securing with holding screw (B). Put aligning bushings (C) over forcing pin (D) and install adapter (E) in C-frame.

A—Aligning Adapter  
B—Holding Screw  
C—Aligning Bushing

D—Forcing Pin  
E—Pin Adapter

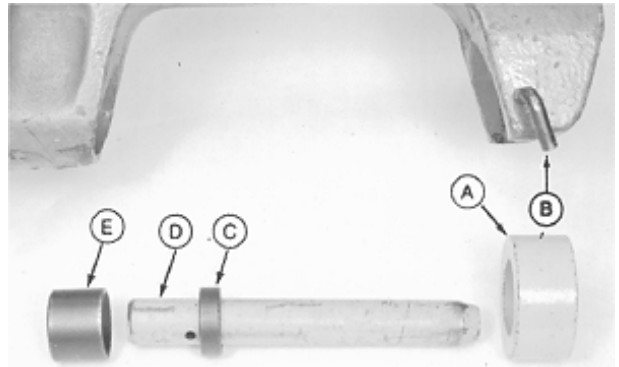

T93556 —UN—01NOV88

Continued on next page

CED.OUTX547,83 -19-16DEC09-3/6

## Track System

5. Position master pin pusher and forcing pin in alignment with master pin using load positioning sling and hoist.
6. Turn ram adjusting screw (2) clockwise with crank until forcing pin (1) contacts master pin.
7. Connect hand pump to pin pusher. Activate pump to remove master pin.
8. Remove forcing pin to separate track.

1—Forcing Pin

2—Ram Adjusting Screw

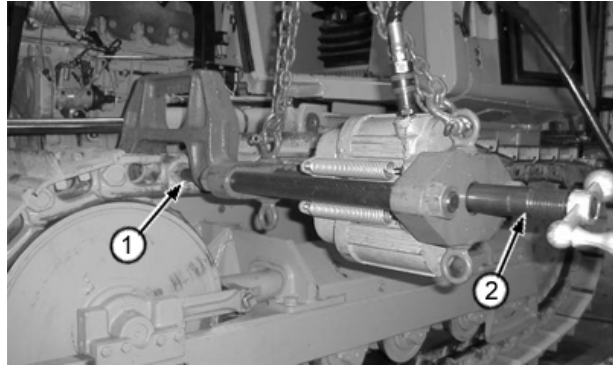

T118576B —UN—23NOV98

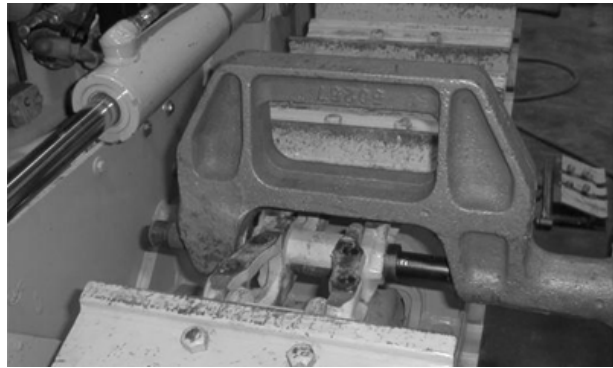

T118577B —UN—23NOV98

Continued on next page

CED,OUTX547,83 -19-16DEC09-4/6

- Pull track chain apart. Remove spacers (B) and washers (A) from between left and right track links.

**⚠ CAUTION: Prevent possible injury from unexpected machine movement. Put shop stands under frame to support machine while removing lower track roller.**

**Specification**

Machine—Approximate  
 Weight..... 8391 kg  
 18 500 lb



T93558 —UN—01NOV88

- Place a jack under both crossbars and raise crawler to provide clearance. Put shop stands under machine.
- Operate crawler and rotate track in the reverse direction. Slowly, unwrap track off drive sprocket.
- Measure track link height. See 450D, 450E, 450G, 450H, 450J, 455D, 455E, 455G, 550A, 550B, 550G, 550H, 550J, 555A, and 555B Link Height. (SP326 Undercarriage Appraisal Manual.)
- Measure track chain pitch.  
 See 450D, 450E, 450G, 450H, 450J, 455D, 455E, 455G, 550A, 550B, 550G, 550H, 550J, 555A, and 555B Chain Pitch—160.0 mm (6.29 in.). (SP326 Undercarriage Appraisal Manual.)  
  
 See 555G, 650G, 650H, 650J, and 605C Chain Pitch—171.05 mm (6.73 in.). (SP326 Undercarriage Appraisal Manual.)
- Measure track bushing outer diameter.  
 See 450D, 450E, 450G, 450H, 450J, 455D, 455E, 455G, 550A, 550B, 550G, 550H, 550J, 555A, and

**A—Washer (4 used)**

**B—Spacer (2 used)**

555B Bushing Outer Diameter—Normal Impact, Sealed Chain (Caliper). (SP326 Undercarriage Appraisal Manual.)

See 450D, 450E, 450G, 450H, 450J, 455D, 455E, 455G, 550A, 550B, 550G, 550H, 550J, 555A, and 555B Bushing Outer Diameter—High Impact, Sealed Chain (Caliper). (SP326 Undercarriage Appraisal Manual.)

See 555G, 605C, 650G, 650H, and 650J Bushing Outer Diameter—Normal Impact, Sealed Chain (Caliper). (SP326 Undercarriage Appraisal Manual.)

See 555G, 605C, 650G, 650H, and 650J Bushing Outer Diameter—High Impact, Sealed Chain (Caliper). (SP326 Undercarriage Appraisal Manual.)

Continued on next page

CED,OUTX547,83 -19-16DEC09-5/6

# Track System

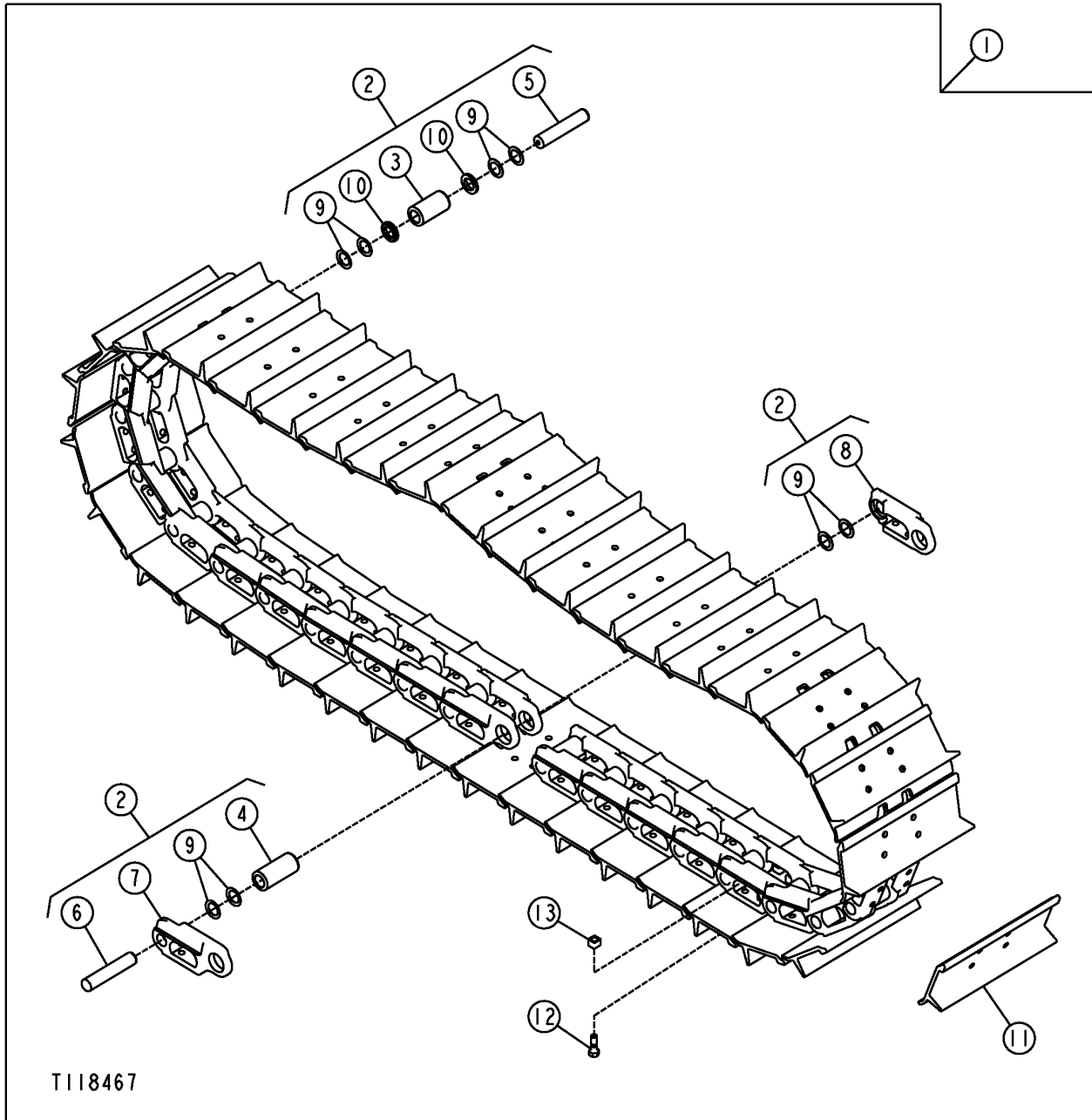

T118467

T118467—UN—23NOV/88

1— Track Chain Assembly  
 2— Track Link Assembly  
 3— Master Bushing  
 4— Bushing

5— Master Pin (Drilled Point on  
 Ends)  
 6— Pin  
 7— Track Link  
 8— Track Link

9— Washers  
 10— Spacers  
 11— Shoes  
 12— Cap Screws

13— Nuts

15. Repair or replace parts as necessary.

CED,OUTX547,83 -19-16DEC09-6/6

### Sealed Track Chain Disassemble and Assemble

1. Sealed track must be removed and disassembled to turn pins and bushings. See Sealed Track Chain Removal. (Group 0130.)
2. See your track press manufacturers operator's manual to disassemble and assemble sealed track chain.

Use the following tooling:

- 450H, 450J, 550H, and 550J:
- Tooling Set A2656-139
  - Saddle 40989

<sup>1</sup>For stepped bushing design, use 052657-001 saddle.

650H, 650J, and 605C:

- Tooling Set A2656-139
- <sup>1</sup>Saddle 42101

*NOTE: Wear on pins and bushings does not extend over the entire surface. Turning pins and bushings is determined by the amount of wear.*

3. Turn pins and bushings as required. See Turning Pins and Bushings on Sealed Track Chain. (SP326 Undercarriage Appraisal Manual.)
4. Assemble track chain and install on machine. See Sealed Track Chain Installation. (Group 0130.)

CED,TX03399,5073 -19-08SEP06-1/1

### Sealed Track Chain Installation

**IMPORTANT: Track chain MUST be installed under track frame with wide end of links toward rear of machine or accelerated wear to track chain will occur.**

1. Position track chain under crawler with wide part of links (A) toward rear of crawler.

A—Link



Drive Sprocket End Shown

T118611—UN—23NOV98

Continued on next page

CED,OUTX547,85 -19-01JUN04-1/3

## Track System

2. Put end of chain on sprocket then slowly turn sprocket in forward direction to pull chain across top of frame to front idler.
3. Put two seals (5) into counterbore of end link with seal inside diameters touching.
4. Install master bushing spacers (3) with flat side against seal and push end links together.
5. Install forcing pin to align links (1 and 6), bushing (4), seals (5), and spacers (3).

- |                         |                   |
|-------------------------|-------------------|
| 1—Right Track Link      | 4—Master Bushing  |
| 2—Forcing Pin           | 5—Seals           |
| 3—Master Bushing Spacer | 6—Left Track Link |

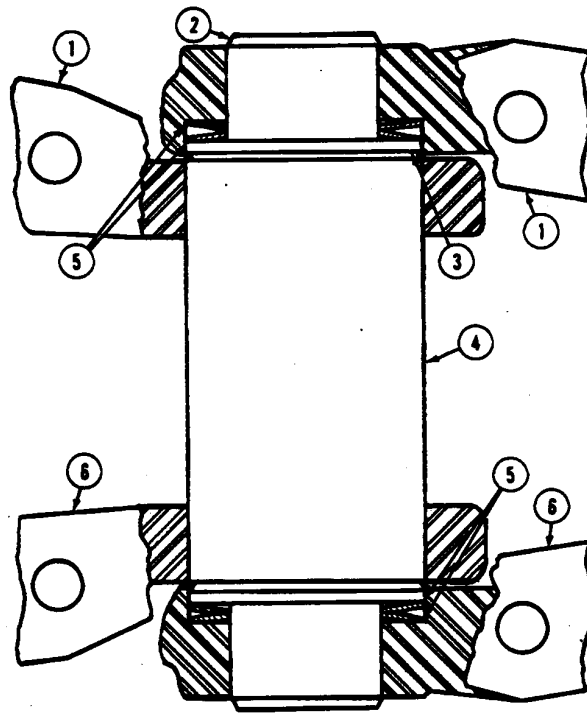

T6043AR — JUN—01NOV88

CED,OUTX547.85 -19-01JUN04-2/3

6. Apply oil to master pin (5).
  7. Position master pin pusher (1) on track.
  8. Press master pin (5) into end links.
- NOTE: If master pin does not fit securely into links, an oversize master pin is recommended.*
9. Install track shoes. See Track Shoe Remove and Install. (Group 0130.)
  10. Adjust track sag. See Adjust Track Sag. (Operators Manual.)

- |                             |                     |
|-----------------------------|---------------------|
| 1—100 Ton Master Pin Pusher | 4—Aligning Bushings |
| 2—Guide Pin                 | 5—Master Pin        |
| 3—Aligning Adapter          | 6—Rear Forcing Pin  |

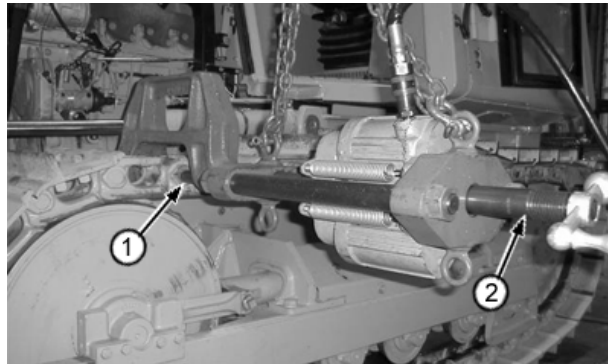

T118576B — JUN—23NOV98

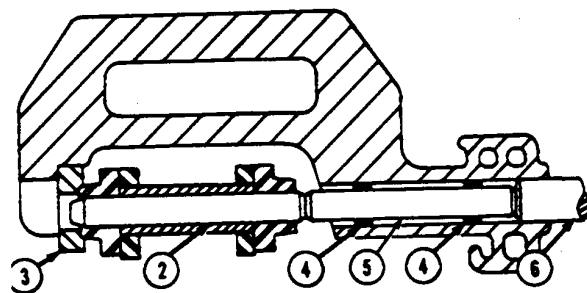

T6043AQ — JUN—01NOV88

CED,OUTX547.85 -19-01JUN04-3/3

### Lubricated Track Chain (Saw Tooth Master Split Link) Remove and Install

1. Rotate track until split link pin is at the top of front idler.
2. Block track at front idler.
3. Put a block on top of recoil spring cover, near front idler to keep chain supported.

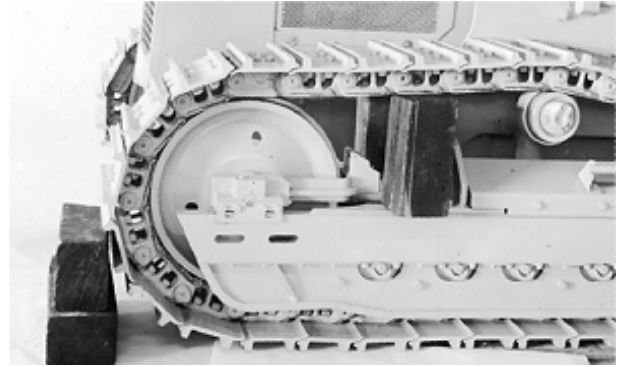

T8058BG—UN—29JUL93

Continued on next page

CED,OUTX547,87 -19-04DEC07-1/4

**CAUTION:** Grease for track adjuster cylinder is under high pressure. Never remove special high pressure grease fitting (2) to release the grease.

If grease does not escape immediately from vent hole (3), the check valve is open. Slowly drive machine forward and reverse until grease escapes; then close check valve.

4. Release track tension:
  - a. Check valve (1) one to three turns counterclockwise to release grease through vent hole (3). DO NOT loosen special grease fitting (2).
  - b. Tighten valve.

**CAUTION:** Track chain will fall to the ground when removing cap screws from shoe to separate master link. DO NOT stand at end of track.

5. Remove track shoe at master split link. See Track Shoe Remove and Install. Group 0130.)

**CAUTION:** Prevent possible injury from unexpected machine movement. Put shop stands under frame to support machine while removing lower track roller.

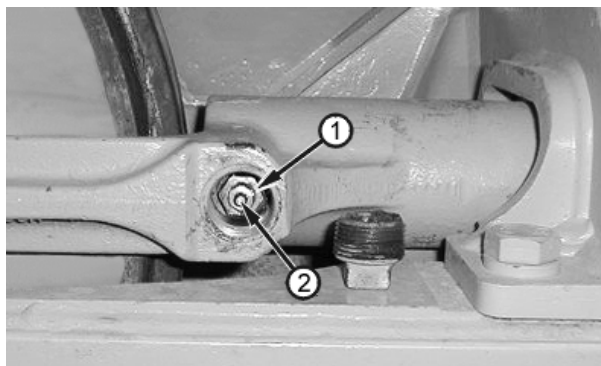

T118012C—UN—23NOV98

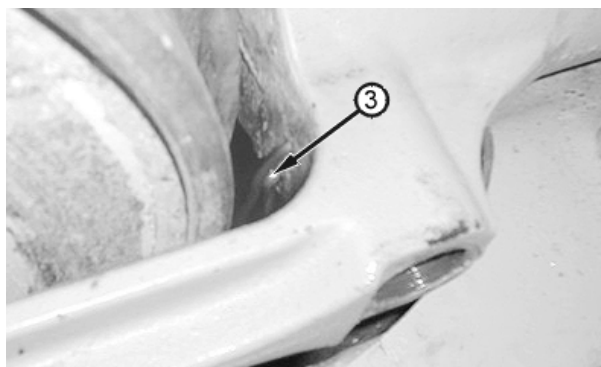

T118013C—UN—23NOV98

1— Check Valve  
2— Grease Fitting  
3— Vent Hole

Machine—Approximate	Specification
Weight.....	8391 kg 18 500 lb

6. Place a jack under both crossbars and raise crawler to provide clearance. Put shop stands under machine.
7. Operate crawler and rotate track in the reverse direction. Slowly, unwrap track off drive sprocket.
8. Measure track link height. See 450D, 450E, 450G, 450H, 450J, 455D, 455E, 455G, 550A, 550B, 550G, 550H, 550J, 555A, and 555B Link Height. (SP326 Undercarriage Appraisal Manual.)
9. Measure track chain pitch.  
See 450D, 450E, 450G, 450H, 450J, 455D, 455E, 455G, 550A, 550B, 550G, 550H, 550J, 555A, and 555B Chain Pitch—160.0 mm (6.29 in.). (SP326 Undercarriage Appraisal Manual.)  
See 555G, 650G, 650H, 650J, and 605C Chain Pitch—171.05 mm (6.73 in.). (SP326 Undercarriage Appraisal Manual.)
10. Measure track bushing outer diameter.  
See 450D, 450E, 450G, 450H, 450J, 455D, 455E, 455G, 550A, 550B, 550G, 550H, 550J, 555A, and 555B Bushing Outer Diameter—Normal Impact, Sealed and Lubricated Chain (Caliper). (SP326 Undercarriage Appraisal Manual.)  
See 450D, 450E, 450G, 450H, 450J, 455D, 455E, 455G, 550A, 550B, 550G, 550H, 550J, 555A, and

555B Bushing Outer Diameter—High Impact, Sealed and Lubricated Chain (Caliper). (SP326 Undercarriage Appraisal Manual.)  
See 450G, 450H, 450J, 455G, 550G, 550H, and 550J Step Bushing Outer Diameter—Normal Impact, Sealed and Lubricated Chain (Caliper). (SP326 Undercarriage Appraisal Manual.)  
See 450G, 450H, 450J, 455G, 550G, 550H, and 550J Step Bushing Outer Diameter—High Impact, Sealed and Lubricated Chain (Caliper). (SP326 Undercarriage Appraisal Manual.)  
See 555G, 650G, 650H, 650J, and 605C Bushing Outer Diameter—Normal Impact, Sealed and Lubricated Chain (Caliper). (SP326 Undercarriage Appraisal Manual.)  
See 555G, 650G, 650H, 650J, and 605C Bushing Outer Diameter—High Impact, Sealed and Lubricated Chain (Caliper). (SP326 Undercarriage Appraisal Manual.)  
See 555G, 650G, 650H, 650J, and 605C Step Bushing Outer Diameter—Normal Impact, Sealed and Lubricated Chain (Caliper). (SP326 Undercarriage Appraisal Manual.)  
See 555G, 650G, 650H, 650J, and 605C Step Bushing Outer Diameter—High Impact, Sealed and Lubricated Chain (Caliper). (SP326 Undercarriage Appraisal Manual.)

Continued on next page

CED,OUTX547.87 -19-04DEC07-2/4

**IMPORTANT: Track chain MUST be installed under track frame with wide end of links (A) toward rear of machine or accelerated wear to track chain will occur.**

11. To join master link, locate master link pin end at the top of the front idler. Put a block at the front of the idler.
12. Apply PM37566 Loctite Silver Anti-Seize Lubricant **LOCTITE®** to mating surfaces of master link.
13. Use a come-along device to bring master link halves together.
14. Install shoe and new caps screws. Apply PM37566 Loctite Silver Anti-Seize Lubricant **LOCTITE®** (or equivalent) to threads and surface under head. Start cap screws by hand to avoid cross-threading.



Drive Sprocket End Shown

T118611 —UN—23NOV98

*LOCTITE is a trademark of Henkel Corporation*

CED.OUTX547,87 -19-04DEC07-3/4

**IMPORTANT: Tighten cap screws to the initial torque using a criss-cross pattern. Repeat pattern for a second time. Finally, turn each cap screw the additional turn using the same pattern.**

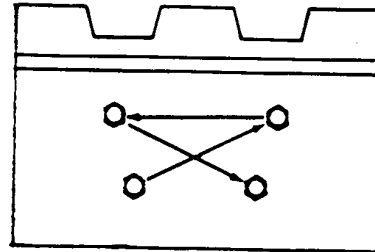

T6352AH —UN—23FEB89

Item	Measurement	Specification
Track Shoe		
450J and 550J Track Shoe Cap Screw (9/16 in.)	Torque	88 N·m Second Pass—Additional 1/3 (120°) turn
650J and 605C Track Shoe Cap Screw (5/8 in.)	Torque	190 N·m Second Pass—Additional 1/3 (120°) turn
450J and 550J Master Split Link Cap Screw (9/16 in.)	Torque	88 N·m Second Pass—Additional 1/2 (180°) turn
650J and 605C Master Split Link Cap Screw (5/8 in.)	Torque	190 N·m Second Pass—Additional 1/2 (180°) turn

CED.OUTX547,87 -19-04DEC07-4/4

### Lubricated Track Chain Disassembly (Turn Bushings and Lubricate Chain)

**NOTE:** The following procedure is for disassembly of track chain to inspect, clean, replace damaged or worn parts, turn bushings, and re-lubricate chain.

If track chain is disassembled only to turn pins and bushings and no parts will be replaced, see Lubricated Track Chain Disassemble and Assemble (Turn Pins and Not Lubricate). (Group 0130.)

1. Remove track shoes and track chain. See Track Shoe Remove and Install. (Group 0130.)  
See Lubricated Track Chain (Saw Tooth Master Split Link) Remove and Install. (Group 0130.)

**NOTE:** A clean track is necessary for proper disassembly.

2. Wash chain with high pressure water. It will not be necessary to wash links before reassembly if chain is thoroughly cleaned.
3. Use the following track press tool sets:

450J and 550J:

- Tooling Set A2656-213
- Saddle 40989

650J:

- Tooling Set A2656-217
- <sup>1</sup>Saddle 42101

**IMPORTANT:** Track press disassembly tools must be in proper alignment with links to prevent broaching of pin and bushing. Damaged link bores cannot be reused.

4. Start disassembly at pen-end half of split link. Check for proper alignment of tools with pin and bushing.

<sup>1</sup>For stepped bushing desing, use saddle 052657-001.

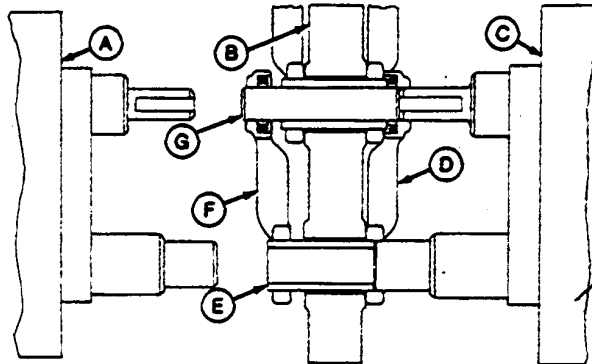

T96266—UN—27OCT88

- |              |             |
|--------------|-------------|
| A—Left Ram   | E—Bushing   |
| B—Saddle     | F—Left Link |
| C—Right Ram  | G—Pin       |
| D—Right Link |             |

5. Make an index mark on bushings to aid in reassembly, when turning bushings 1/2 turn (180°) to expose a new wear surface.

**⚠ CAUTION:** Always wear safety glasses when operating the press. Parts may break or chip, which could create a risk of personal injury.

6. Extend right ram (C) to push pin (G) and bushing (E) from the right link (D). The right link is forced against the side of saddle (B) as pin and bushing are pushed out.
7. Retract right ram. The right link, with seals and thrust ring, will stay on the ram tools.

CED.OUTX547,88 -19-08SEP06-1/4

8. Extend left ram (A) to push the pin (C) and bushing (F) from left link (G). The left link is forced against the side of saddle (B) as pin and bushing are pushed out.
9. Retract left ram. The left link, with seal and thrust ring, will remain on the ram tools.
10. Remove links, bushing, and thrust rings from press.

- |             |              |
|-------------|--------------|
| A—Left Ram  | E—Right Link |
| B—Saddle    | F—Bushing    |
| C—Pin       | G—Left Link  |
| D—Right Ram |              |

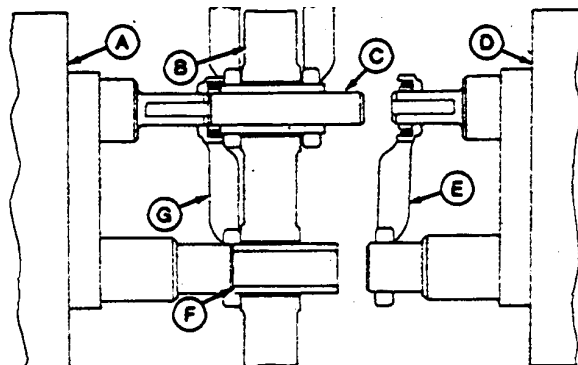

T96267—UN—27OCT88

Continued on next page

CED.OUTX547,88 -19-08SEP06-2/4

## Track System

11. Inspect parts as they are disassembled to determine which ones can be reused.

If there is internal wear at any joint, replace seal ring, pin, bushing, thrust ring, and load ring. These parts must be replaced to successfully re-lubricate chain.

12. If pin and bushing contains oil when disassembled, new pins, seal rings, bushings, thrust ring and load rings are not necessary. Do not remove usable seals from link counterbore. Do not remove any dirt from around seals.
13. Repeat steps to disassemble rest of chain.
14. Remove rubber stopper (F) from pins using a drill.

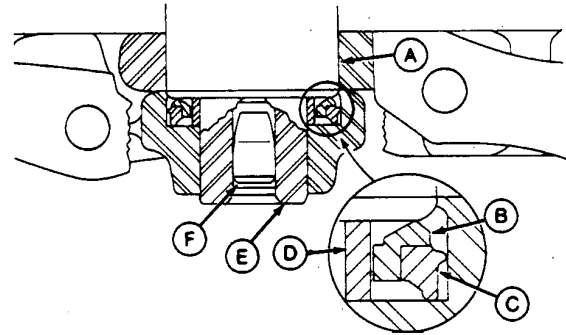

A—Bushing  
B—Seal Ring  
C—Load Ring  
D—Thrust Ring  
E—Pin  
F—Stopper

T6682AJ —UN—01NOV88

CED,OUTX547,88 -19-08SEP06-3/4

15. Inspect pin ends. If the chamfer is missing due to wear, grind a 3 mm (0.12 in.) x 10° chamfer on pin. If chamfer is missing in stopper hole, add new 4 mm (0.16 in.) x 30° chamfer.

### Lubricated Track—Specification

Pin—Chamfer.....	3 mm x 10°
	(0.12 in.) x 10°
Pin—Chamfer.....	4 mm x 30°
	(0.16 in.) x 30°

16. Clean pins, bushings, and thrust rings in solvent.

A—4 mm (0.16 in.)  
B—30°  
C—10°  
D—3 mm (0.12 in.)

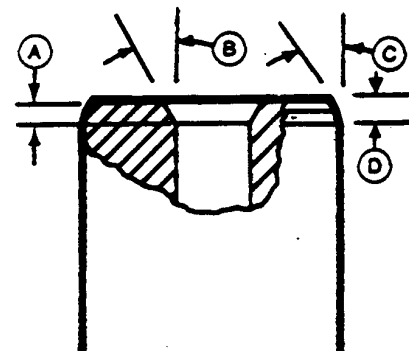

T96269 —UN—27OCT88

CED,OUTX547,88 -19-08SEP06-4/4

### Lubricated Track Chain Assembly (Turn Bushings and Lubricate Chain)

**CAUTION:** Prevent possible injury from unexpected machine movement. Make sure all control levers of press are in the NEUTRAL position.

1. Assemble track using following track press tool sets.

450J and 550J:

- Tooling Set A2656-213
- Saddle 40989

650J:

- Tooling Set A2656-217
- <sup>1</sup>Saddle 42101

2. Apply a mixture of 50% alcohol and 50% water to stopper (A) and install using JDG589 Stopper Installer (B).

<sup>1</sup>For stepped bushing design, use 052657-001 saddle.

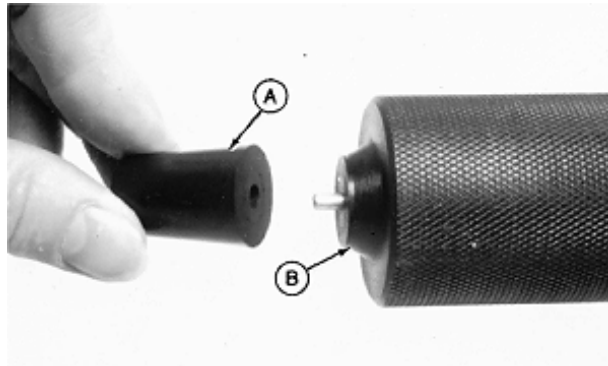

A—Stopper

B—Stopper Installer

T96272 —UN—27OCT88

CED.OUTX547,89 -19-08SEP06-1/14

**NOTE:** The pin end halves of master split link must be temporarily assembled to bushing end halves of link for proper positioning on plungers. Pin end halves will have to be separated later for installation at end of chain. Split links are a matched set and must be assembled as a set.

3. Assemble master split link halves using master shoe bolts and washers (as required). Tighten bolts just enough to hold links together.
4. Install assembled split links on ram plungers.
5. Install bushing (A) in front seat of saddle (B) so the mark is 180° opposite original location to expose a new wear surface.

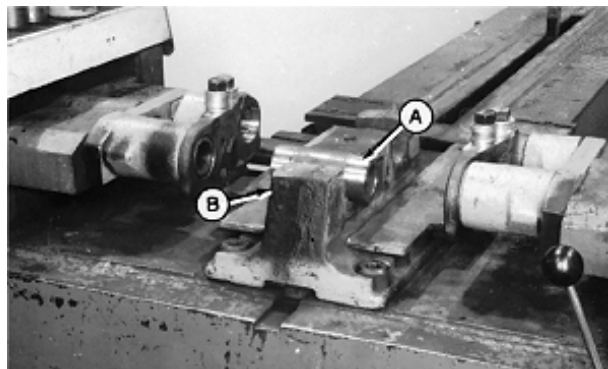

A—Bushing

B—Saddle

T96273 —UN—27OCT88

Continued on next page

CED.OUTX547,89 -19-08SEP06-2/14

6. Adjust track press pressure relief valve setting.

**Lubricated Track—Specification**

450J and 550J	
Pressure Relief	
Valve Setting—Force	
(Maximum).....	284 088 N
	(63 840 lb force)
650J Pressure Relief	
Valve Setting—Force	
(Maximum).....	355 110 N
	(79 800 lb force)

7. Advance left ram until left split link contacts saddle.  
Advance right ram until it stops to press split link and bushing assembly together.

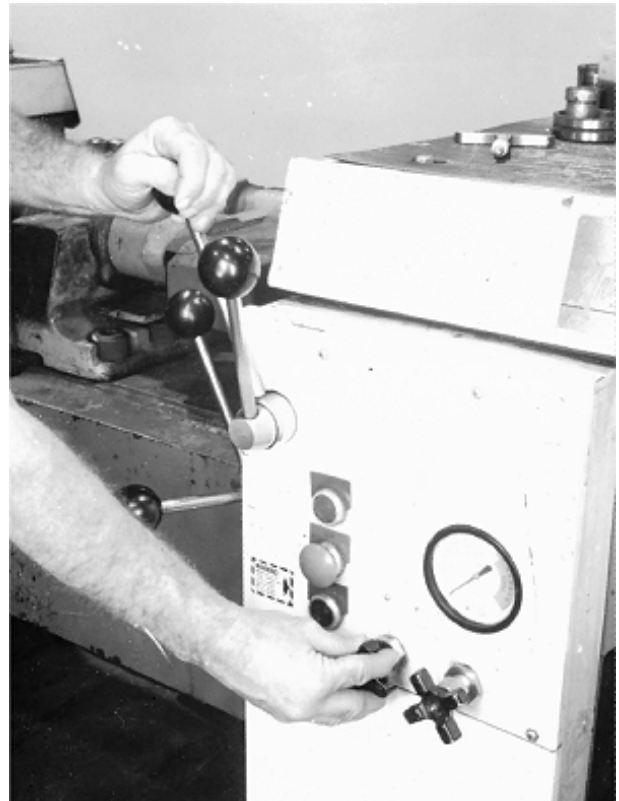

T96274 —UN—27OCT88

CED,OUTX547,89 -19-08SEP06-3/14

8. Measure bushing projection from shoulder of link using a depth micrometer. Bushing projection determines clearance between overlapping links and proper spacing of link bolt holes.

**Lubricated Track—Specification**

450J and 550J Bushing	
Protection—Distance.....	1.63—2.13 mm
	(0.064—0.084 in.)
650J Bushing	
Protection—Distance.....	1.45—1.96 mm
	(0.057—0.077 in.)

9. If bushing projection does not meet specification, check pressure setting or adjust shim packs behind plungers. Only first two joints must be checked for proper bushing projection.



T96275 —UN—27OCT88

Continued on next page

CED,OUTX547,89 -19-08SEP06-4/14

## Track System

10. Apply track chain lubricant to bushing ends before next set of links are installed.



T96276 —UN—27OCT88

CED.OUTX547,89 -19-08SEP06-5/14

**IMPORTANT: Pins must be installed so cross-drilled hole is toward link wear surface or they may break when chain is used. To make assembly easier, install all pins so holes in end are toward same side of chain.**

11. Install pin in bushing so cross-drilled hole (B) is toward link wear surface. Install all pins so hole (A) in end is toward same side of chain, either left or right.

A—Cross-Drilled Hole

B—Cross-Drilled Hole

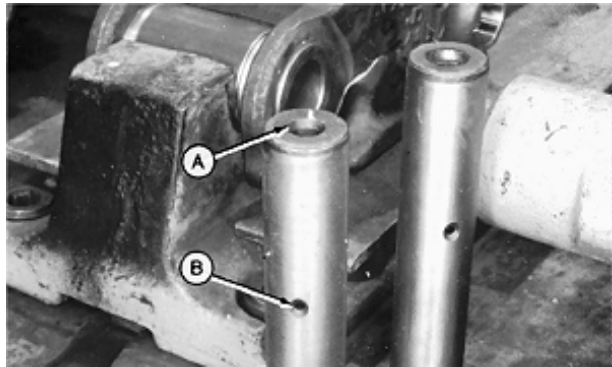

T96277 —UN—27OCT88

CED.OUTX547,89 -19-08SEP06-6/14

12. Install a thrust ring on each end of pin.  
13. Move completed split link assembly to rear seat of saddle.



T96278 —UN—27OCT88

Continued on next page

CED.OUTX547,89 -19-08SEP06-7/14

## Track System

14. Apply LOCTITE ® plastic gasket to link bore. The sealant prevents loss of vacuum or lubricant leakage through pin to link joint.



T96279 —UN—27OCT88

LOCTITE is a registered trademark of Loctite Corp.

CED,OUTX547,89 -19-08SEP06-8/14

15. Install bushing (D) in front saddle seat. Install left link (A) and right link on ram plungers.

Assemble load ring (C) and seal ring (B). Install assembly into link (A) counterbore so pointed lip of seal ring is toward bushing (D).

A—Link Counterbore  
B—Seal Ring

C—Load Ring  
D—Bushing

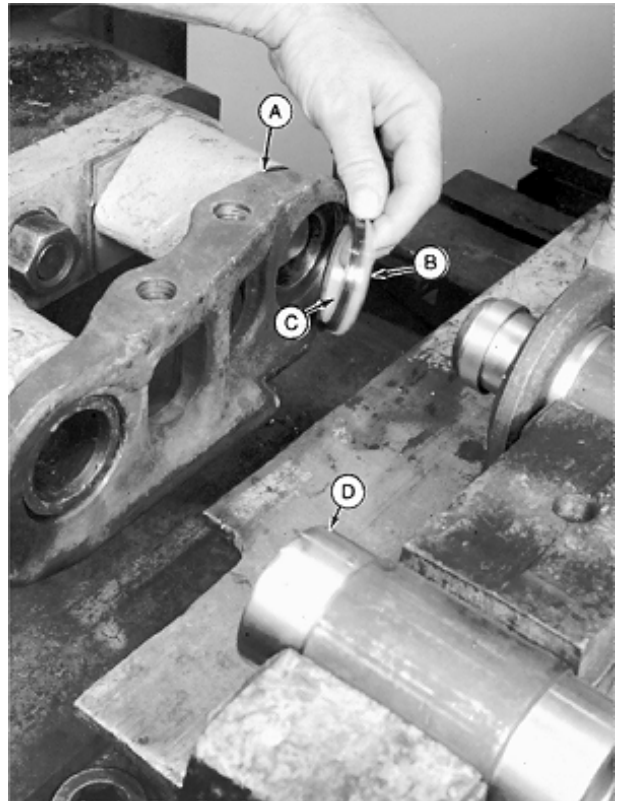

T7158AU —UN—12APR90

Continued on next page

CED,OUTX547,89 -19-08SEP06-9/14

## Track System

16. Advance left ram until left link contacts saddle.  
Advance right ram until it stops (plungers in both rams against shim pack).

A—Left Ram  
B—Saddle  
C—Pin  
D—Plunger  
E—Right Ram

F—Right Link  
G—Bushing  
H—Shims  
I—Left Link

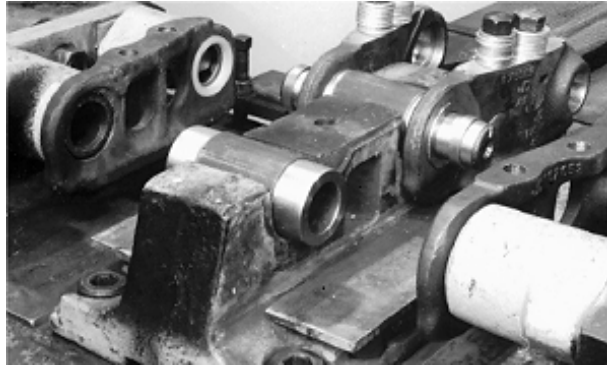

T96282 —UN—27OCT88

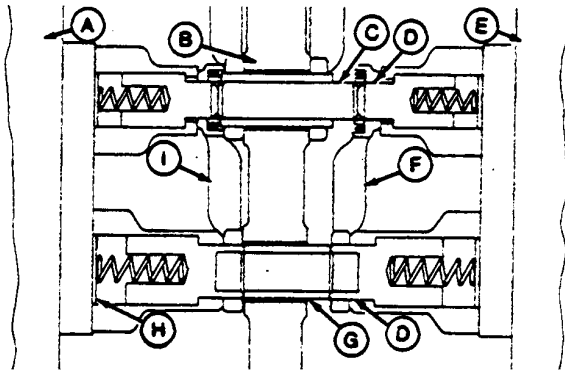

T96283 —UN—27OCT88

CED,OUTX547,89 -19-08SEP06-10/14

*NOTE: To ensure zero end play in joint, special spacers must be fabricated using a section of bushing.*

17. Retract left ram. Install special spacer (A) between the joint in rear seat of saddle and ram.

**IMPORTANT: Too much pressure will crush the thrust rings.**

18. Advance left ram using only minimum force required to push joint tight. Pressure must be approximately one-half the relief valve setting.

A—Special Spacer

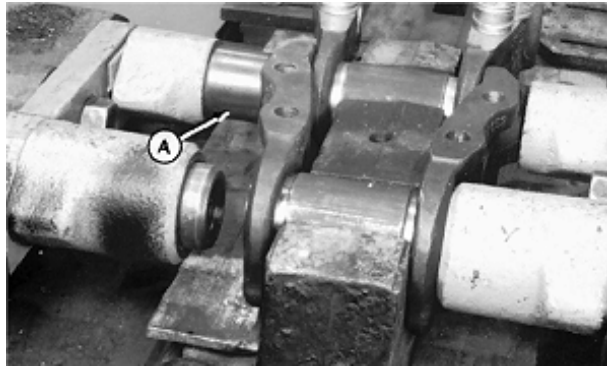

T96284 —UN—27OCT88

Continued on next page

CED,OUTX547,89 -19-08SEP06-11/14

19. After one complete joint has been assembled, check end play of track links to make sure bushing, thrust rings, and link counterbore faces are pressed solid against each other. Position base of dial indicator on one link assembly and pointer against the other link assembly.
20. Pry link assemblies in one direction then in opposite direction to measure the amount of end play. End play must be zero.
21. As track chain is being further assembled, end play may be checked by flexing each joint after each link assembly is pressed together. End play is correct if links cannot be rotated by hand.

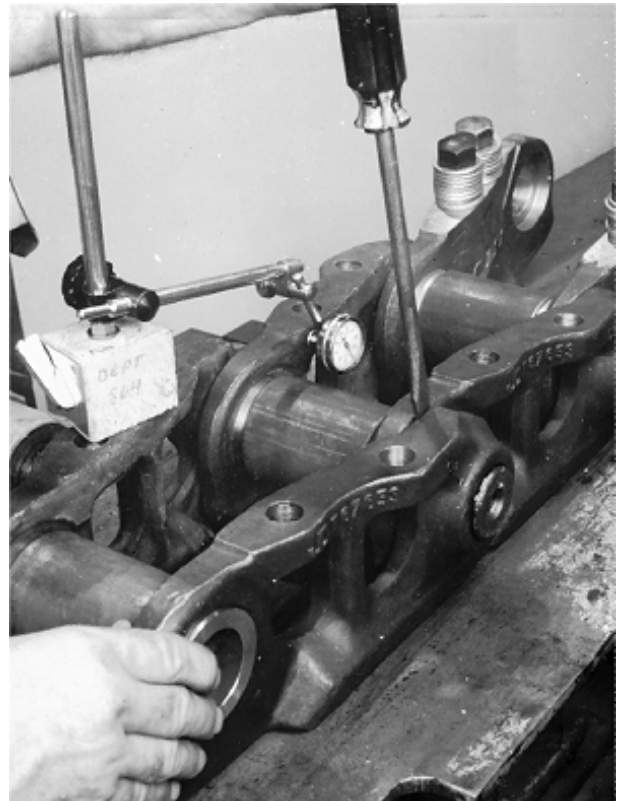

T96285 —UN—27OCT88

CED,OUTX547,89 -19-08SEP06-12/14

22. As chain is being assembled, check to make sure there is some clearance between the overlapping face of links, using a feeler gauge. If links contact each other, check bushing projection.

**Lubricated Track—Specification**

450J and 550J Bushing	
Protection—Distance.....	1.63—2.13 mm (0.064—0.084 in.)
650J Bushing	
Protection—Distance.....	1.45—1.96 mm (0.057—0.077 in.)

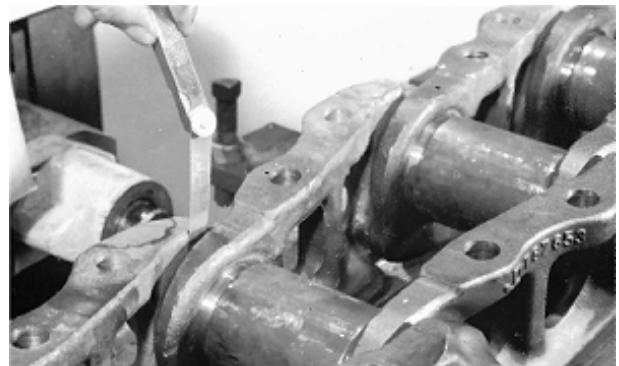

T96286 —UN—27OCT88

Continued on next page

CED,OUTX547,89 -19-08SEP06-13/14

## Track System

23. Add oil (SAE 80W 90) using a D0890 Seal Tester and Lubricator and A2679 Nozzle (C). Push nozzle through stopper all the way into pin. Depress control lever on the handle enough to draw a vacuum of 68—102 kPa (20—30 in. Hg) as indicated on the gauge.

**Lubricated Track—Specification**

Gauge—Vacuum..... 68—102 kPa  
(20—30 in. Hg)

24. Release lever. If there is no decrease in vacuum for a minimum of five seconds, the joints are sealed. If there is a vacuum decrease, seals are not sealing and the joint must be taken apart and repaired.

25. Add oil by depressing the second lever. Oil pressure (read on the same gauge) must be 140—205 kPa (1.4—2.0 bar) (20—30 psi) after both levers are released.

**Lubricated Track—Specification**

Oil—Pressure..... 140—205 kPa  
(1.4—2.0 bar)  
(20—30 psi)

26. Slowly pull nozzle out to allow any compressed air to escape through nozzle from first hole (A) to second hole (B).

27. Repeat Steps 10—25 for all joints.

28. Install assembled split links on ram plungers, and advance rams to press split links together.

29. Install lubricated track chain. See Lubricated Track Chain (Saw Tooth Master Split Link) Remove and Install. (Group 0130.)

30. Install track shoes. See Track Shoe Remove and Install. (Group 0130.)

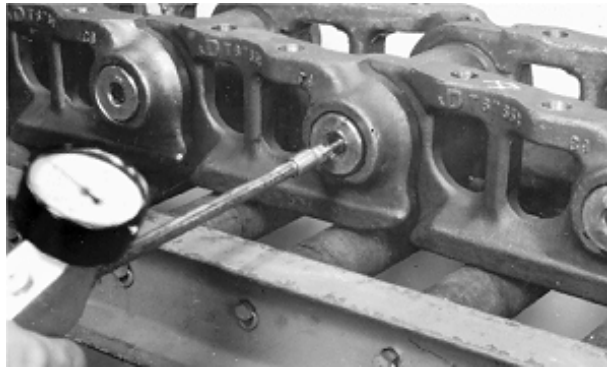

T96287 —UN—01NOV88

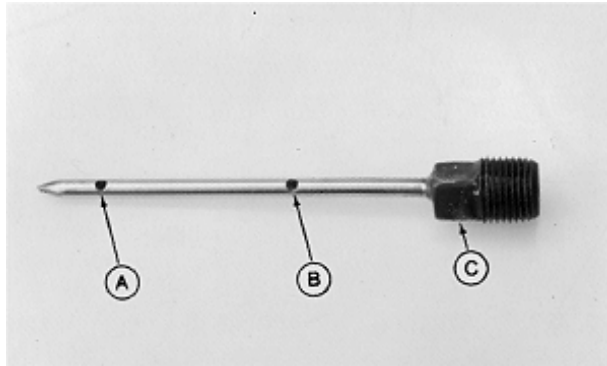

T6465AY —UN—01NOV88

**A—Nozzle First Hole**  
**B—Nozzle Second Hole**

**C—Nozzle**

CED.OUTX547.89 -19-08SEP06-14/14

### Lubricated Track Chain Disassemble and Assemble (Turn Pins and Not Lubricate)

**NOTE:** The following procedure is for disassembly of track chain only to turn pins and bushings. (Chain is not re-lubricated after assembly.)

If this procedure does not apply to repair job, see Lubricated Track Chain Assembly (Turn Bushings and Lubricate Chain). (Group 0130.)

1. Remove track shoes. See Track Shoe Remove and Install. (Group 0130.)
2. Use the following track press tool sets:  
 450J and 550J:
  - Tooling Set A2656-213
  - Saddle 40989
 650J:
  - Tooling Set A2656-217
  - <sup>1</sup>Saddle 42101

**IMPORTANT:** Track press disassembly tools must be in proper alignment with links to prevent broaching of pin and bushing. Damaged links cannot be reused.

3. Check for proper alignment of tools with pin and bushing.
4. Make an index mark on bushings and pins to aid in assembly, when turning bushings 1/2 turn (180°) to expose a new wear surface.

<sup>1</sup>For stepped bushing design, use 052657-001 saddle.

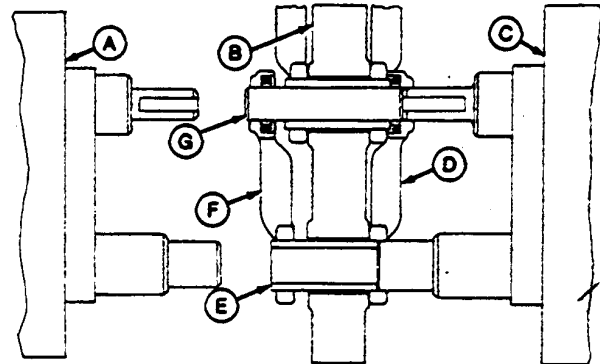

A—Left Ram  
 B—Saddle  
 C—Right Ram  
 D—Right Link  
 E—Bushing  
 F—Left Link  
 G—Pin

**CAUTION:** Always wear safety glasses when operating the press. Parts may break or chip, which could create a risk of personal injury.

5. Extend right ram (C) to push pin (G) and bushing (E) from the right link (D). The right link is forced against the side of saddle (B) as the pin and bushing are pushed out.
6. Track right ram again. The right link, with seals and thrust ring, will stay on the ram tools.

CED,OUTX547,90 -19-08SEP06-1/10

T96266—UN—27OCT88

7. Extend left ram (A) to push the pin (C) and bushing (F) from the left link (G). The left link is forced against the side of saddle (B) as pin and bushing are pushed out.
8. Retract left ram. The left link, with seal and thrust ring, will remain on the ram tools.
9. Remove links and bushing from press.
10. Repeat Steps 4—9 to disassemble rest of chain.
11. All pins, bushings, seals, and thrust rings are used for reassembly, because chain is not re-lubricated. Do not remove stopper and plug from pins. Do not remove seals from track links.

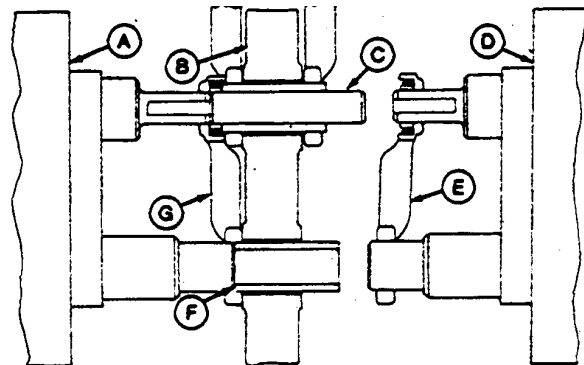

A—Left Ram  
 B—Saddle  
 C—Pin  
 D—Right Ram  
 E—Right Link  
 F—Bushing  
 G—Left Link

Continued on next page

CED,OUTX547,90 -19-08SEP06-2/10

T96267—UN—27OCT88

12. Inspect pin ends for wear. If there is no chamfer, grind a new 3 mm (0.12 in.) x 10° chamfer.

**Lubricated Track—Specification**

Pin—Chamfer..... 3 mm x 10°  
(0.12 in.) x 10°

A—10°

B—3 mm (0.12 in.)

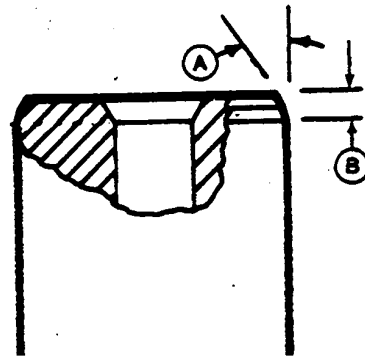

T5798AJ—UN—26OCT88

CED.OUTX547,90 -19-08SEP06-3/10

13. Smooth area of track link wear (A) using a grinder, if necessary.

A—Track Link Wear

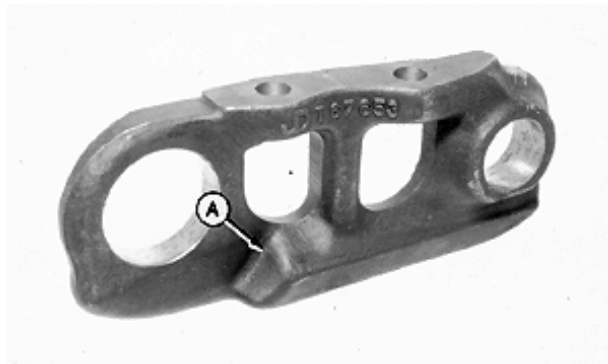

T96289—UN—27OCT88

CED.OUTX547,90 -19-08SEP06-4/10

14. Assemble track links using the following track press tool sets:

450J and 550J:

- Tooling Set A2656-213
- Saddle 40989

650J:

- Tooling Set A2656-217
- <sup>1</sup>Saddle 42101

**NOTE:** Pin end halves of master split link must be temporarily assembled to bushing end halves of link for proper positioning on plungers. Pin end halves will later have to be separated for installation at end of chain. Split links are a matched set and must be assembled as a set.

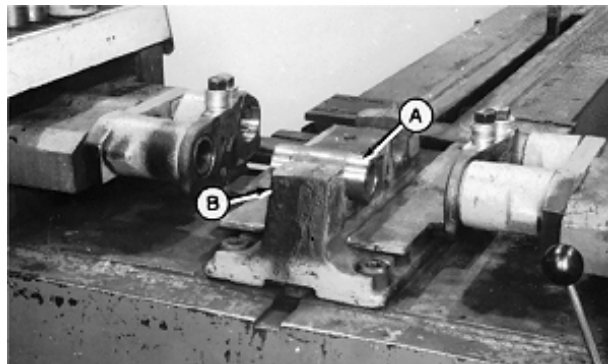

T96273—UN—27OCT88

A—Bushing

B—Saddle

15. Assemble master split link halves using master shoe bolts and washers (as required). Tighten bolts just enough to hold link together.

16. Install assembled split links on ram plungers.

<sup>1</sup>For stepped bushing design, use 052657-001 saddle.

17. Install bushing (A) in front seat of saddle (B) so the mark is 180° opposite original location to expose a new wear surface.

Continued on next page

CED.OUTX547,90 -19-08SEP06-5/10

18. Adjust track press pressure relief valve setting.

**Lubricated Track—Specification**

450J and 550J	
Pressure Relief	
Valve Setting—Force	
(Maximum).....	284 088 N
	(63 840 lb force)
650J Pressure Relief	
Valve Setting—Force	
(Maximum).....	355 110 N
	(79 800 lb force)

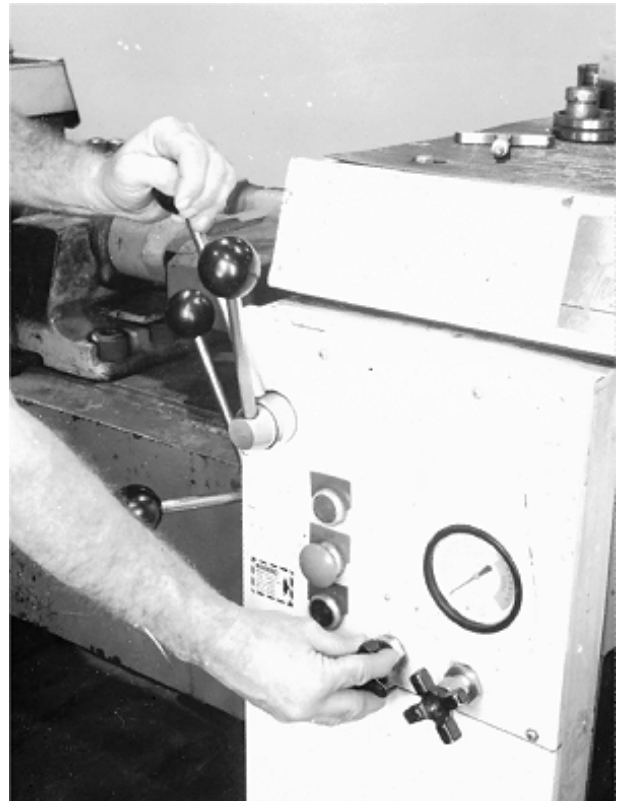

T96274 —UN—27OCT88

CED,OUTX547,90 -19-08SEP06-6/10

**IMPORTANT: Pins must be installed so cross-drilled hole is toward link wear surface or they may break when chain is used.**

19. Turn pin end-for-end to get a new wear surface, then install it into bushing so cross-drilled hole (B) is toward link wear surface. Install all pins so hole (A) in end of pin is toward the same side of chain, either left or right side.

**A—Hole in End of Pin**

**B—Cross-Drilled Hole**

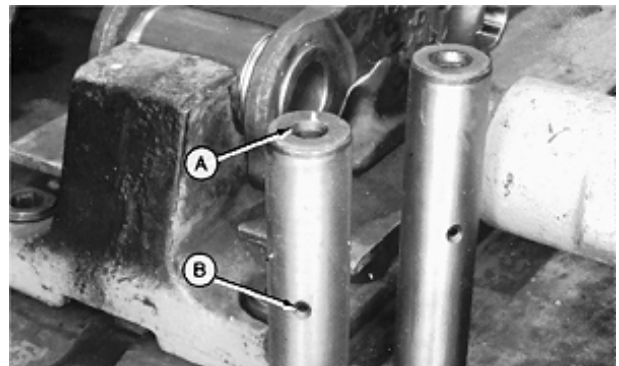

T96277 —UN—27OCT88

Continued on next page

CED,OUTX547,90 -19-08SEP06-7/10

## Track System

20. Install a thrust ring on each end of pin.
21. Move completed link assemble to rear seat of saddle.

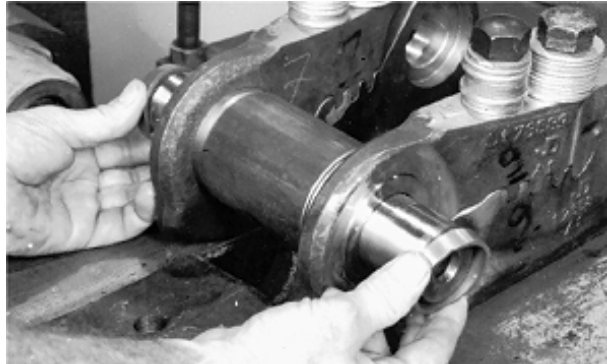

T96278 —UN—27OCT88

CED.OUTX547,90 -19-08SEP06-8/10

22. Install bushing (G) on front saddle seat. Install left and right links on ram plungers.
23. Advance left ram until left link contacts the saddle. Advance right ram until link is pressed together and bolts can be installed.

A—Left Ram  
B—Saddle  
C—Pin  
D—Plunger  
E—Right Ram

F—Right Link  
G—Bushing  
H—Plunger Shims  
I—Left Link

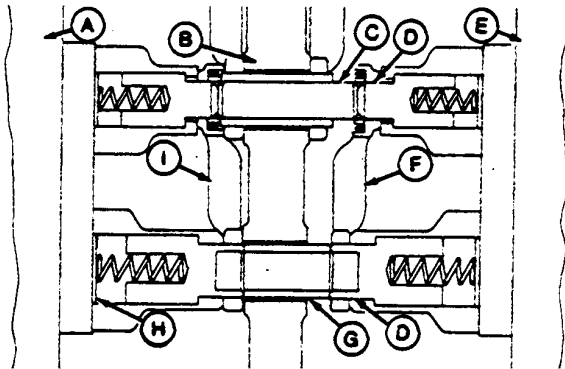

T96283 —UN—27OCT88

CED.OUTX547,90 -19-08SEP06-9/10

24. As chain is being assembled, check to make sure there is some clearance between the overlapping face of links using a feeler gauge. If links contact each other, check bushing projection.

### Lubricated Track—Specification

450J and 550J Bushing	
Protection—Distance.....	1.63—2.13 mm (0.064—0.084 in.)
650J Bushing	
Protection—Distance.....	1.45—1.96 mm (0.057—0.077 in.)

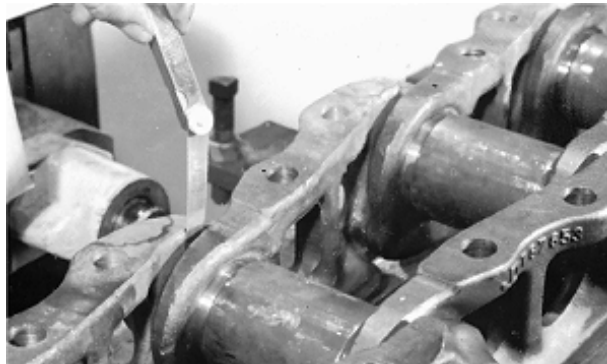

T96286 —UN—27OCT88

25. Repeat Steps 14—25 to assemble rest of chain.
26. Install assembled split link on ram plungers and advance rams to press split links together.
27. Install assembled split links on ram plungers.
28. Advance ram to press split links together until the joint is tight. Protect split link ends from damage during handling.

29. For procedure to install shoes and tighten cap screws see Track Shoe Remove and Install. (Group 0130.). For procedure to assemble split link and shoe see Lubricated Track Chain (Saw Tooth Master Split Link) Remove and Install. (Group 0130.)

CED.OUTX547,90 -19-08SEP06-10/10

### Front Idler Remove and Install

1. Disconnect track chain. See Sealed Track Chain Removal. (Group 0130.)  
See Lubricated Track Chain (Saw Tooth Master Split Link) Remove and Install. (Group 0130.)
2. Remove cap screws (1) from both sides.

**⚠ CAUTION: The approximate weight of idler is 82 kg (181 lb).**

#### Front Idler—Specification

Front Idler—Weight..... 82 kg Approximate  
(181 lb) Approximate

3. Attach hoist and slide front idler forward off track frame.
4. Install idler on track frame. Install and tighten four cap screws and washers (1).

#### Front Idler—Specification

Adjusting Cylinder  
Yoke-to-Idler Bracket  
Cap Screws—Torque.....163 N·m  
(120 lb-ft)

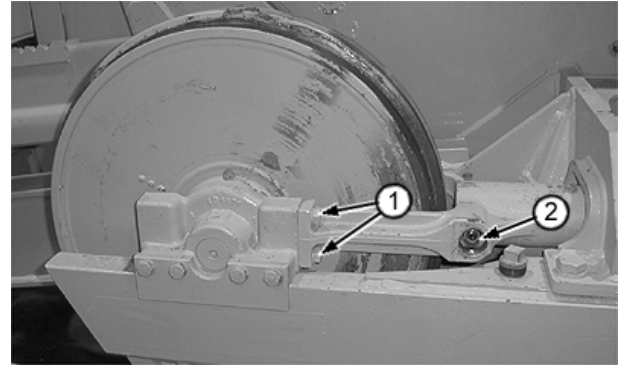

T118526B —UN—17NOV98

1— Cap Screw

2— Check Valve (Not used)

5. Connect track chain. See Sealed Track Chain Installation. (Group 0130.)  
See Lubricated Track Chain (Saw Tooth Master Split Link) Remove and Install. (Group 0130.)
6. Adjust idler. See Front Idler Adjustment. (Group 0130.)

CED,OUTX547,92 -19-01JUN04-1/1

### Front Idler Disassemble, Inspect, and Assemble

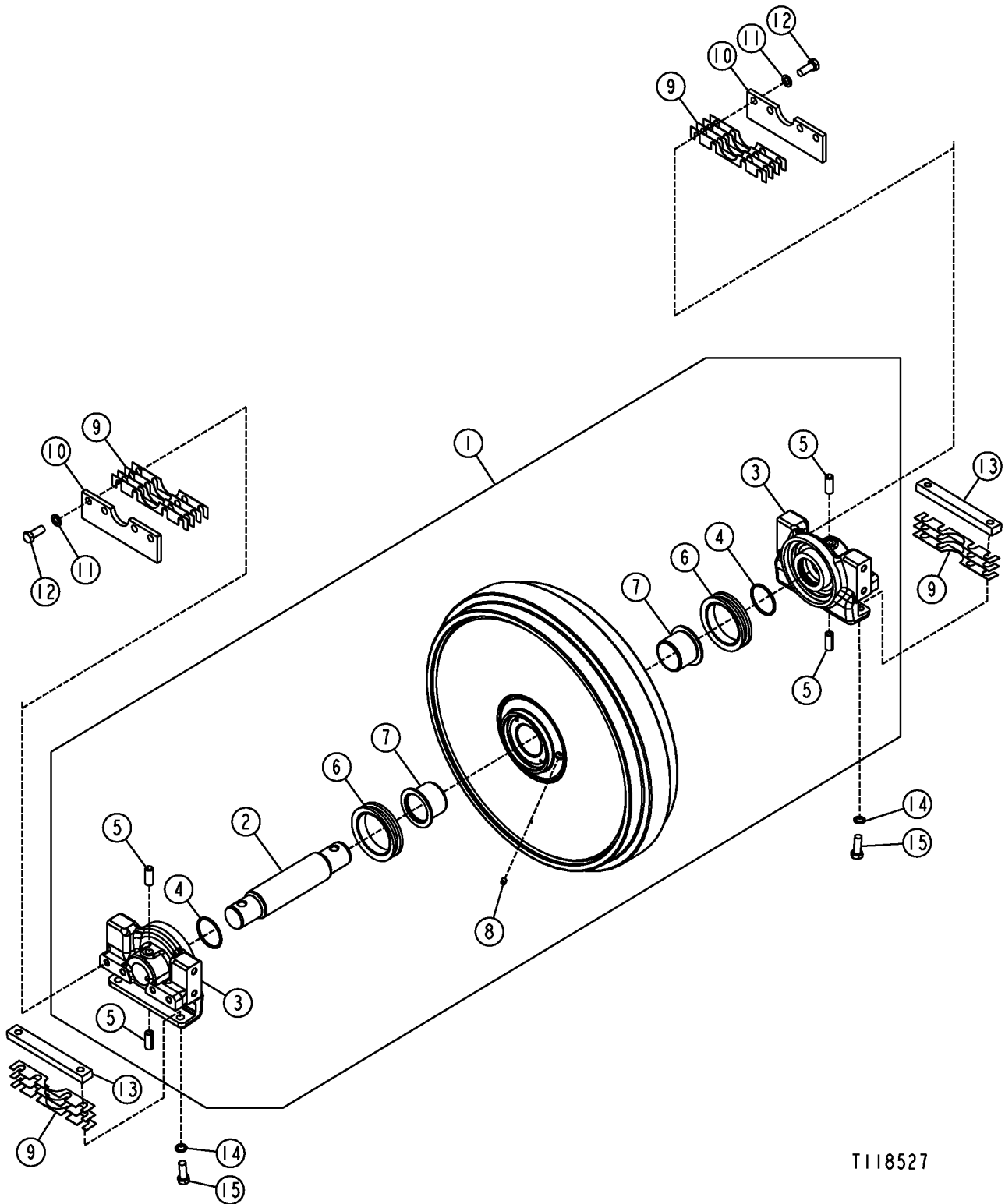

T118527

T118527—UN—11DEC98

Continued on next page

CED.OUTX547,93-19-23JAN06-1/3

## Track System

- 1— Idler Assembly
- 2— Shaft
- 3— Bracket (2 used)
- 4— O-Ring (2 used)

- 5— Spring Pin (4 used)
- 6— Metal Face Seal (2 used)
- 7— Bushing (2 used)
- 8— Pipe Plug

- 9— Shim (as required)
- 10— Guide (2 used)
- 11— Washer (8 used)
- 12— Cap Screw (8 used)

- 13— Wear Plate (2 used)
- 14— Washer (4 used)
- 15— Cap Screw (4 used)

1. Remove cap screws and washers to remove wear strips and shims.
2. Drive pins (5) out.

3. Remove brackets (3), O-rings (4) and metal face seals (6).
4. Remove shaft (2) and inspect bushings (7). Replace if necessary.

**IMPORTANT: Keep metal face seals (6) lubricated and together at all times while disassembled.**

CED,OUTX547,93 -19-23JAN06-2/3

5. Measure front idler wear. See 450H, 450J, 550H, and 550J Front Idler Flange Height. (SP326 Undercarriage Appraisal Manual.)  
See 650H, 650J, and 605C Front Idler Flange Height. (SP326 Undercarriage Appraisal Manual.)

*NOTE: 100% worn is the maximum allowable height of flange for rebuilding wear surface.*

Measure height of flange using a depth gauge such as JT05521 200 mm Ruler, JT05534 Right Angle Attachment, and D05231ST 300 mm Ruler from JT05518 or JT05523 Undercarriage Inspection Service Tool Kit.

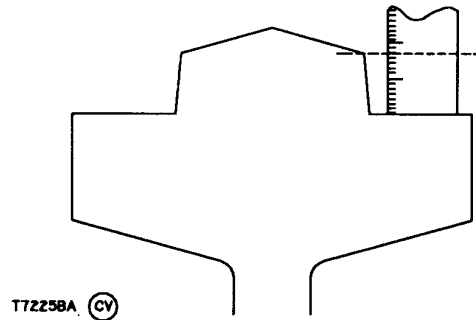

T72258A — UN—21FEB90

6. Install new bushings. Drive in bushings until bottomed.

**IMPORTANT: Lubricate idler bushings with oil before installing shaft.**

7. Apply clean hydraulic oil to bushings (7).
8. Inspect metal face seals. See Metal Face Seals Inspection. (Group 0130.)
9. Install new metal face seals, if necessary.

10. Install shaft (2), O-rings (4), and brackets (3).
11. Drive in spring pins (5).
12. Install guides, wear plates and shims. Adjust idler. See Front Idler Adjustment. (Group 0130.)
13. Fill idler with oil. See Front Idler Oil Level Check. (Group 0130.)

CED,OUTX547,93 -19-23JAN06-3/3

**Front Idler Adjustment**

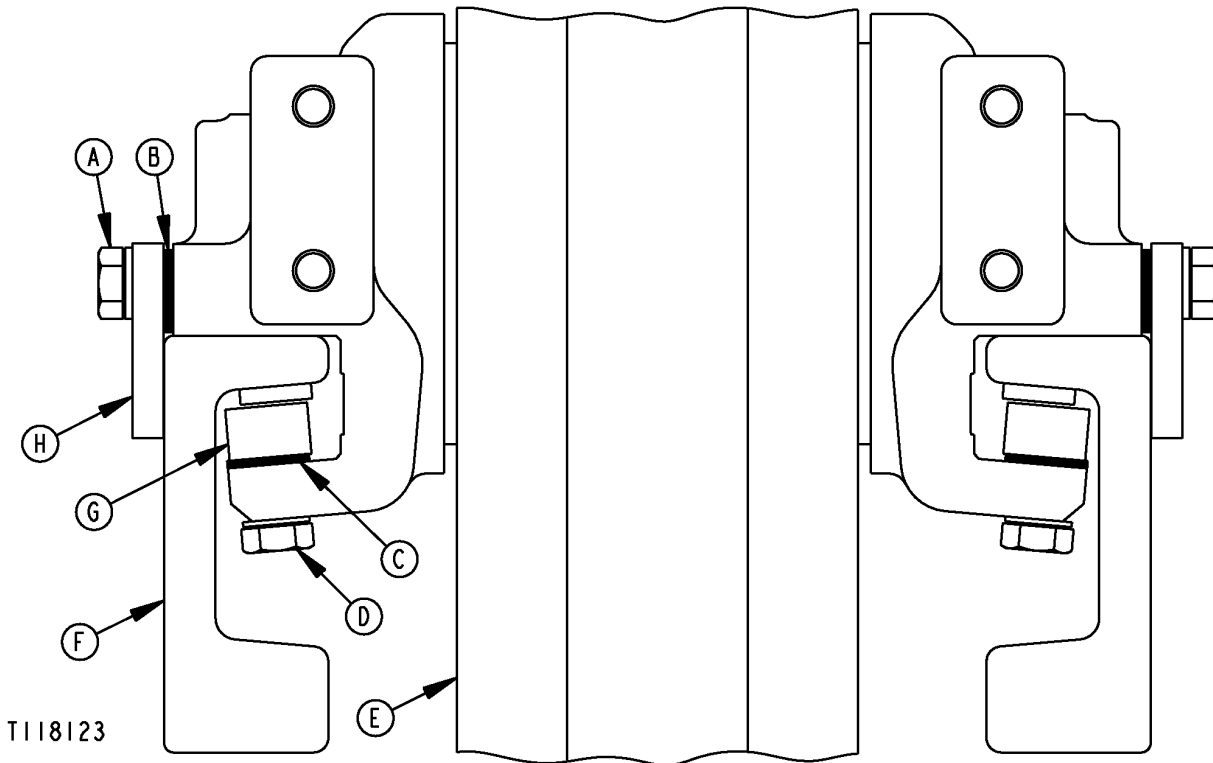

T118123

T118123—UN—02NOV98

**A—Cap Screw (8 used)**  
**B—Shim (as required)**

**C—Shim (as required)**  
**D—Cap Screw (4 used)**

**E—Idler**  
**F—Track Frame**

**G—Wear Strip (2 used)**  
**H—Guide Plate (2 used)**

**NOTE:** Idler is to be removed for shimming the bottom wear strips only.

1. Remove front idler. See Front Idler Remove and Install. (Group 0130.).
2. Install bottom wear strip (G). Add or remove shims (C) under wear strip to obtain 0.8 mm (0.030 in.) or less clearance.

**Front Idler—Specification**

Bottom Wear Strip	
Shimming—Clearance.....	0.8 mm or less (0.030 in.) or less

3. Tighten cap screws (A).

**Front Idler—Specification**

Idler Bracket-to- Wear Strip Cap	
Screws—Torque.....	163 N·m (120 lb·ft)

4. Install front idler. See Front Idler Remove and Install. (Group 0130.)
5. Check guide plate (H) clearance. Add or remove shims (B) to obtain 0.8 mm (0.030 in.) clearance.

**Front Idler—Specification**

Guide Plate	
Shimming—Clearance.....	0.8 mm (0.030 in.)

6. Tighten cap screws (D).

**Front Idler—Specification**

Guide Plate-to-Idler Bracket Cap	
Screws—Torque.....	163 N·m (120 lb·ft)

CED.OUTX547.95 -19-01JUN04-1/1

## Front Idler Oil Level Check

**NOTE:** *Idlers and rollers are typically sealed for life and the plug in the side is used by the factory to fill the oil cavity initially. Opening this plug to check the oil level introduces the potential to allow contamination entry or leakage from the plug. The plug should only be removed after a seal repair, etc.*

Removing the idler oil level plug (1) does not always indicate oil level. Possible vacuum in the oil cavity can keep oil from flowing out. Idlers that appear low or out of oil may have sufficient oil. Applying a small amount of low volume forced air into the idler will overcome the vacuum and allow a small amount of oil to flow from idler.

**NOTE:** *The oil fill hole should be on outside of idler on the right side of machine. The oil fill hole should be on the inside of idler on the left hand side of the machine.*

1. Rotate plug opening (A) to a 45° angle.
2. Remove the oil level fill plug (A).

If oil flows out, oil level is correct.

If oil does not flow, insert the nozzle of a plastic bottle into the hole and squeeze air pressure into idler. A

*TEFLON is a registered trademark of Du Pont Co.*

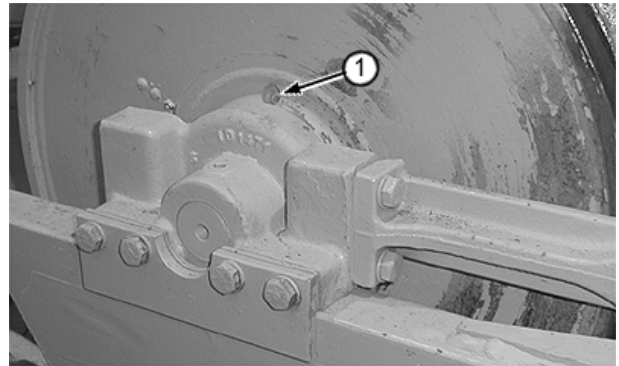

T118598B —UN—23NOV98

slight amount of pressure inside the idler will relieve any vacuum and allow oil to flow from fill hole.

3. Add proper oil slowly using oil can.
4. Add oil until oil flows from oil level hole.
5. Apply pipe sealant or TEFLON® tape to new plug. Install and tighten oil level plug.

### Front Idler—Specification

Oil Level Plug—Torque.....	41 ± 4 N·m (30 ± 3 lb·ft)
----------------------------	------------------------------

LW86157,000017D -19-09MAY07-1/1

### Track Tension Adjuster Remove and Disassemble

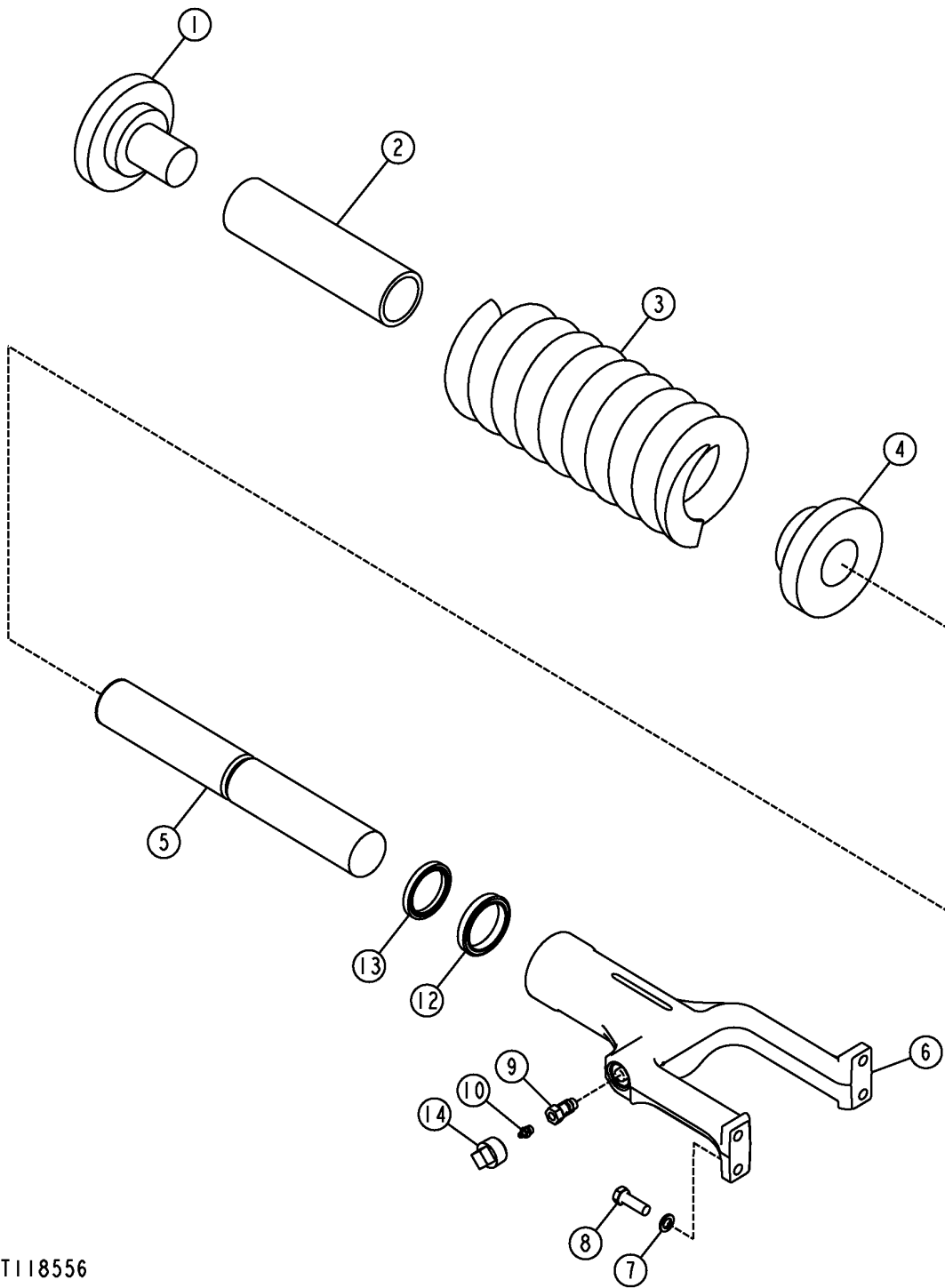

T118556

T118556—UN—23NOV98

Continued on next page

LW86157,000017E -19-09MAY07-1/2

## Track System

- 1— Cap
- 2— Tube
- 3— Compression Spring
- 4— Cap (Front End)

- 5— Piston
- 6— Yoke
- 7— Washer (4 used)
- 8— Cap Screw (4 used)

- 9— Check Valve
- 10— Grease Fitting
- 11— Not used
- 12— Seal

- 13— Seal
- 14— Plug

**⚠ CAUTION: Grease for track adjuster cylinder is under high pressure. Never remove special grease fitting to release the grease. If grease does not escape immediately from vent hole with relief valve open, slowly drive machine in forward and reverse until grease escapes. DO NOT disassemble parts unless you follow the correct procedure and have correct tools.**

**If an accident occurs, see a doctor immediately. Any fluid injected into the skin must be surgically removed within a few hours or gangrene may result. Doctors unfamiliar with this type of injury may call the Deere & Company Medical Department in Moline, Illinois, or other knowledgeable medical source.**

1. Remove front idler. See Front Idler Remove and Install. (Group 0130.)

2. Remove adjuster assembly from track frame.

**IMPORTANT: Do not pull piston from track adjusting yoke unless seal and piston seal are to be replaced or seals will be damaged.**

3. To aid disassembly, remove grease fitting (10) to prevent suction.
4. Pull track adjusting piston (5) from yoke (6).
5. Remove and discard scraper seal (13) and yoke seal (12).
6. Inspect and clean all parts.

LW86157,000017E -19-09MAY07-2/2

### Track Tension Adjuster Assemble and Install

1. Fold seal (B) as shown and install into yoke (A) with seal lip into bore first.
2. Install scraper seal (C) using 57 mm and 73 mm disks.
3. Install piston.

A—Track Adjuster Yoke  
B—Seal

C—Scraper Seal

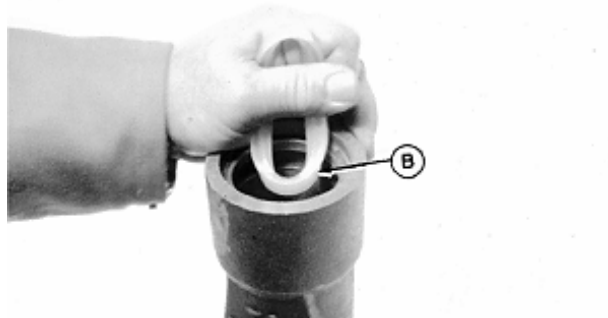

T7247BP —UN—09APR90

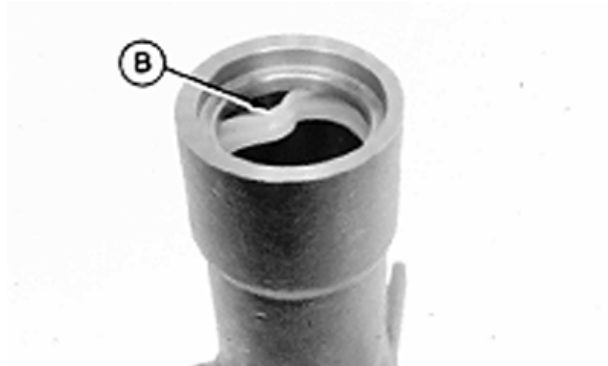

T118646 —UN—30NOV98

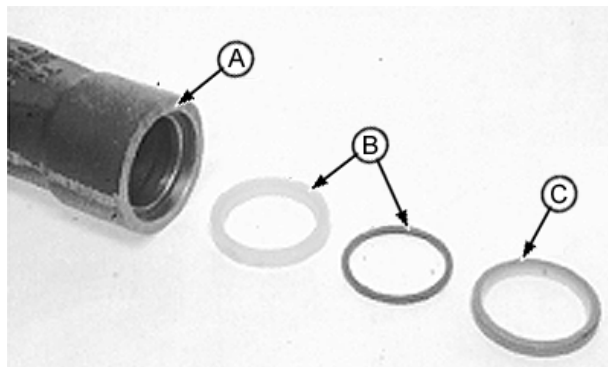

T118647 —UN—30NOV98

LW86157,0000181 -19-09MAY07-1/2

4. Install track adjuster in track frame.
5. Install grease fitting and plug (2).
6. Install idler and tighten cap screws (1).

#### Hydraulic Track Tension Adjuster—Specification

Adjusting Cylinder  
Yoke-to-Idler Bracket  
Cap Screws—Torque.....163 N·m  
(120 lb-ft)

1— Cap Screw (4 used)

2— Grease Fitting and Plug

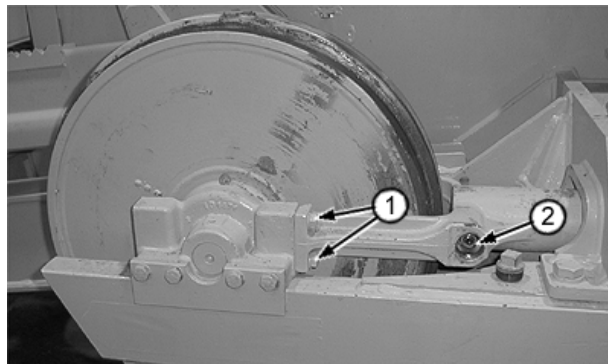

T118626B —UN—17NOV98

LW86157,0000181 -19-09MAY07-2/2

### Track Idler Recoil Spring Remove and Install

**IMPORTANT:** When sliding idler assemble forward, do not pull track adjusting piston from yoke as scraper seal may damage piston seal.

1. Slide front idler with hydraulic track tension adjuster assembly forward.
2. Remove cover.
3. Thoroughly clean threads of rear cap.

**CAUTION:** Always use the special bolt to prevent accidental release of idler recoil spring.

4. Apply John Deere NEVER-SEEZ ® Lubricant and insert a T16678 Special Bolt and a 51 mm (2.0 in.) spacer through track spring retainer plate and into rear cap..

**Track Recoil Spring—Specification**

Spacer—Width..... 51 mm  
(2.0 in.)

Tighten bolt until spring compresses to 404 mm (15.9 in.) between outer end of front cap and rear cap.

**Track Recoil Spring—Specification**

Spring—Length..... 404 mm  
(15.9 in.)

**CAUTION:** Spring or rod may break if dropped while handling, transporting or disassembling. Nicks or weld craters in spring and rod assembly can cause stress concentration

*NEVER-SEEZ is a registered trademark of Emhart Chemical Group.*

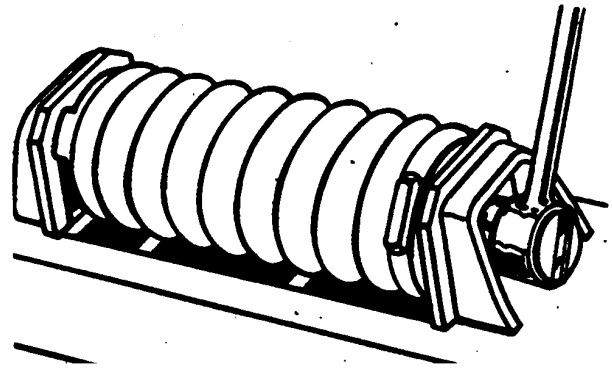

T6555DH—UN—01JUN89

resulting in a weak spot that may result in immediate or eventual failure creating a risk of personal injury. Put a heavy protective covering around spring assembly when handling, transporting or disassembling.

**A compression tool must be used for disassembly and assembly because of the extreme preload on spring.**

5. Remove spring.
6. Release compression on track spring immediately after removal. See Track Idler Recoil Spring Disassemble and Assemble. (Group 0130.)
7. Install spring and cover.
8. Slide front idler with hydraulic track tension adjuster back, aligning spring nut with piston.

LW86157,000017F -19-09MAY07-1/1

## Track Idler Recoil Spring Disassemble and Assemble

**⚠ CAUTION:** Spring or rod may break if dropped while handling, transporting or disassembling. Nicks or weld craters in spring and rod assembly can cause stress concentration resulting in a weak spot that may result in immediate or eventual failure creating a risk of personal injury. Put a heavy protective covering around spring assembly when handling, transporting or disassembling.

A compression tool must be used for disassembly and assembly because of the extreme preload on spring.

1. Put a 10-ton jack on bottom of ST4920 compression tool (A). For instructions on making this tool see ST4920 Track Recoil Spring Disassembly and Assembly Tool. (Group 9900.)

Remove nuts (B) and top plate (C).

2. Put recoil spring in compression tool.

### Track Recoil Spring—Specification

450J and 550J Recoil Spring—Approximate	
Free Length.....	454 mm 18.0 in.
Test Length at 54	
535—64 019 N (12	
260—14 392 lb force).....	
	376 mm 14.80 in.
650J and 605C Recoil Spring—Approximate	
Free Length.....	433 mm 17.0 in.
Test Length at 68	
058—83 982 N (15	
300—18 880 lb force).....	
	376 mm 14.80 in.

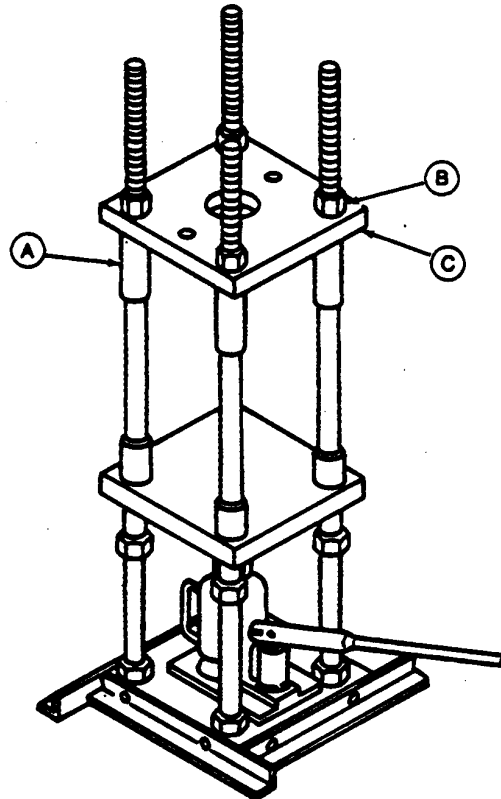

A—ST4920 Compression Tool    C—Top Plate  
B—Nuts

T6657DY—UN—25OCT88

Continued on next page

LW86157,0000180 -19-09MAY07-1/4

## Track System

3. Install DFT1087 Recoil Spring Guard Tool (F). For instructions on making this tool see DFT1087 Track Recoil Spring Disassembly and Assembly Guard Tool. (Group 9900.)
4. Install plate (A) and nuts (B) from ST4920 Recoil Spring Tool to secure spring.
5. Be sure cap screw head (C) fits through hole in plate.

**IMPORTANT: Cap screw head MUST be centered through hole in plate for proper operation of tool.**

6. Compress spring until cap screw (C) fully extends through hole in plate.
7. Remove cap screw (C).
8. Slowly release jack pressure.
9. Remove nuts and plate.
10. Remove spring.

A—Plate  
B—Nut (4 used)  
C—Cap Screw Head

D—Recoil Spring  
E—Hole in Plate  
F—DFT1087 Recoil Spring Guard Tool

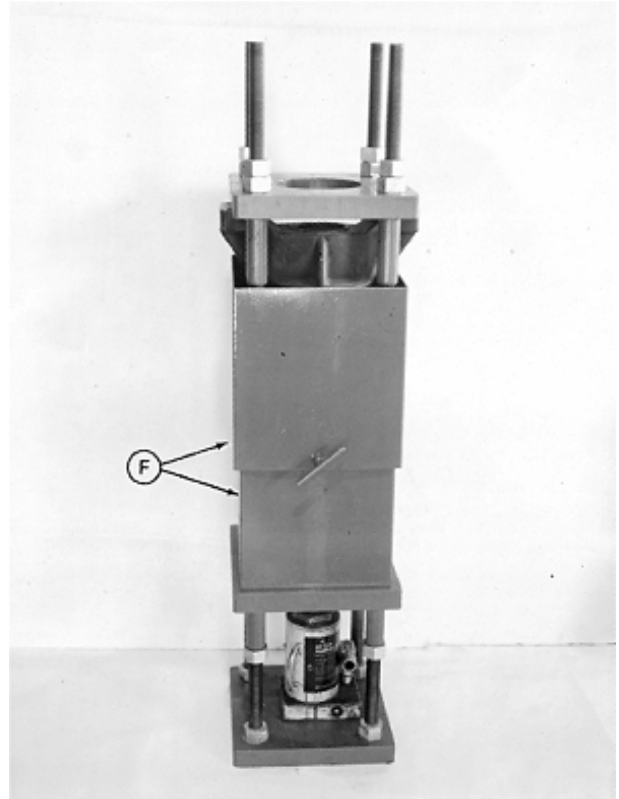

T7126AA —UN—15SEP89

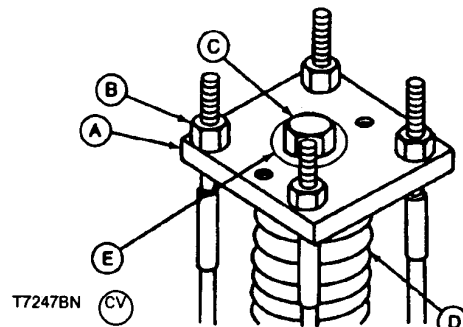

T7247BN —UN—09APR90

Continued on next page

LW86157,0000180 -19-09MAY07-2/4

Track System

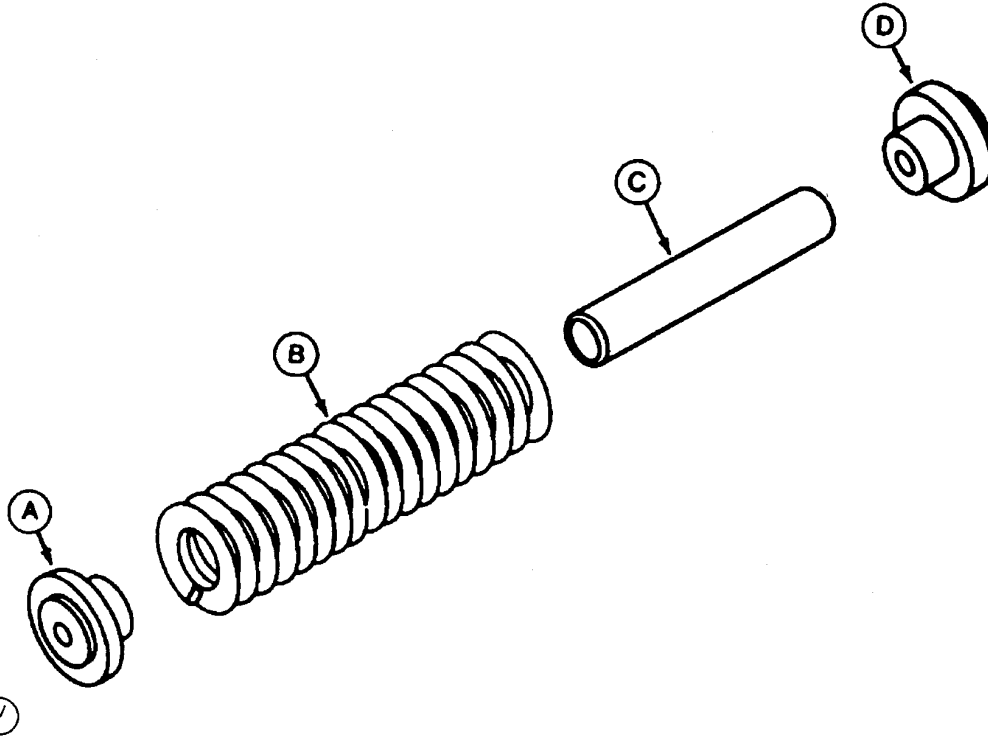

A—Rear End Cap

B—Spring

C—Stop Tube

D—Front End Cap

11. Remove parts.

12. Check spring for nicks or weld craters. Replace as necessary.

13. Install parts.

Continued on next page

LW86157,0000180 -19-09MAY07-3/4

## Track System

14. Install 10-ton jack on bottom of compression tool.
15. Put caps, tube and recoil spring (D) in compression tool so spring is centered.
16. Install DFT1087 Recoil Spring Guard Tool (F). For instructions on making this tool see DFT1087 Track Recoil Spring Disassembly and Assembly Guard Tool. (Group 9900.)
17. Install plate (A) and nuts (B) to secure spring.
18. Operate jack to compress spring.
19. Apply John Deere NEVER-SEEZ<sup>®</sup> Lubricant to threads of special cap screw (C). Install special cap screw through hole (E). Be sure cap screw threads fully engage end cap.
20. Slowly release jack and remove nuts and plate.
21. Install spring assembly. See Track Idler Recoil Spring Remove and Install. (Group 0130.)

A—Plate  
 B—Nut (4 used)  
 C—Cap Screw Head

D—Recoil Spring  
 E—Hole in Plate  
 F—DFT1087 Recoil Spring Guard Tool

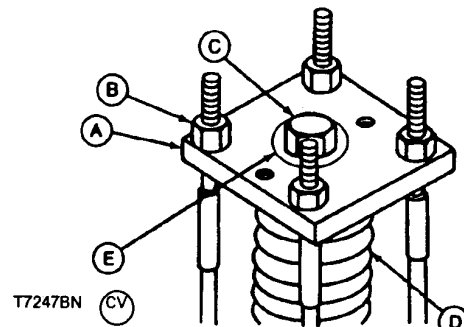
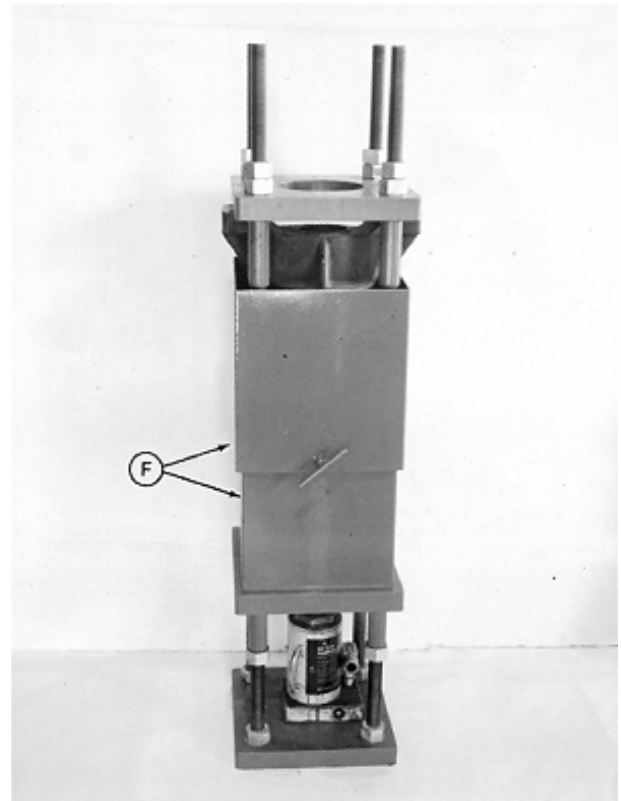

*NEVER-SEEZ is a registered trademark of Emhart Chemical Group.*

LW86157,0000180 -19-09MAY07-4/4

T7126AA —UN—15SEP89

T7247BN —UN—09APR90

### Sprocket Remove and Install

*NOTE: Sealed sprocket shown.*

1. Disconnect track chain. See Sealed Track Chain Removal. (Group 0130.)  
See Lubricated Track Chain (Saw Tooth Master Split Link) Remove and Install. (Group 0130.)
2. Raise rear of machine using a 89 000 N (10-ton) floor jack and block securely.
3. Remove guards (1 and 2).

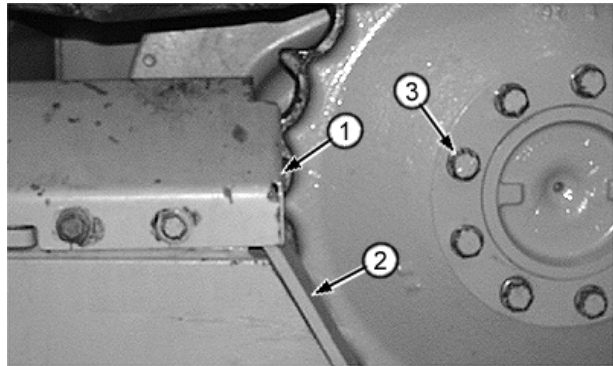

T118653B—UN—30NOV98

**⚠ CAUTION: Approximate weight of sprocket is 59 kg (130 lb).**

**Sprocket—Specification**

Sprocket—Weight..... 59 kg Approximate  
(130 lb)

4. Using a C-clamp and hoist, remove cap screws (3) and lift sprocket from final drive.
5. Sprocket is not repairable. If excessively worn or damaged, replace.
6. Install sprocket. Tighten cap screws.

**Sprocket—Specification**

Drive Sprocket-to-Axle Shaft Cap  
Screws—Torque.....420 N·m Lubricated  
(310 lb-ft) Lubricated

7. Install sprocket guards. Tighten cap screws.

1— Guard  
2— Guard

3— Cap Screws

**Sprocket—Specification**

Sprocket Guard Upper  
Cap Screws—Torque.....624 N·m  
(460 lb-ft)

Sprocket Guard Lower  
Cap Screws—Torque.....203 N·m  
(150 lb-ft)

8. Install track chain. See Sealed Track Chain Installation. (Group 0130.)  
See Lubricated Track Chain (Saw Tooth Master Split Link) Remove and Install. (Group 0130.)

CED.OUTX547,101 -19-30SEP05-1/1

### Track Frame Remove and Install

1. Remove track. See Sealed Track Chain Removal. (Group 0130.)  
See Lubricated Track Chain (Saw Tooth Master Split Link) Remove and Install. (Group 0130.)

**CAUTION:** Approximate weight of track frame assembly is 862 kg (1900 lb).

#### Track Frame—Specification

Track Frame  
 Assembly—Weight..... 939 kg Approximate  
 (2070 lb) Approximate

2. Attach hoist to frame using two chains to balance track frame.
3. Position two 10-ton floor stands to support machine when removing frame.
4. Remove attaching hardware. Pull frame assembly free of crossbars. Inspect and repair. Remove parts as necessary.
5. Install frame and install cap screws (3).
6. Align sprocket with rear track roller. Torque cap screws to specification.

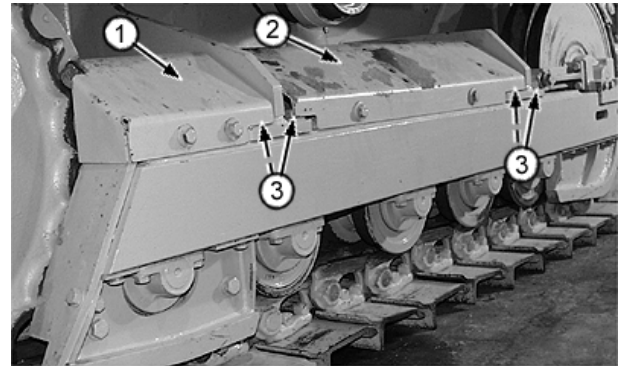

1 — Rear Cover  
 2— Spring Cover

3— Cap Screws (10 used)

#### Track Frame—Specification

Frame-to-Track-Frame  
 Cap Screws—Torque.....620 N·m  
 (460 lb-ft)

7. Install track. See Sealed Track Chain Installation. (Group 0130.)  
See Lubricated Track Chain (Saw Tooth Master Split Link) Remove and Install. (Group 0130.)

CED,OUTX547,102 -19-27AUG08-1/1

T118665B —UN—30NOV98

### Track Frame Disassemble and Assemble

1. Remove track. See Sealed Track Chain Removal. (Group 0130.) or see Lubricated Track Chain (Saw Tooth Master Split Link) Remove and Install. (Group 0130.)
2. Remove track frame. See Track Frame Remove and Install. (Group 0130.)

1 — Rear Cover  
 2— Spring Cover

3— Cap Screws (10 used)

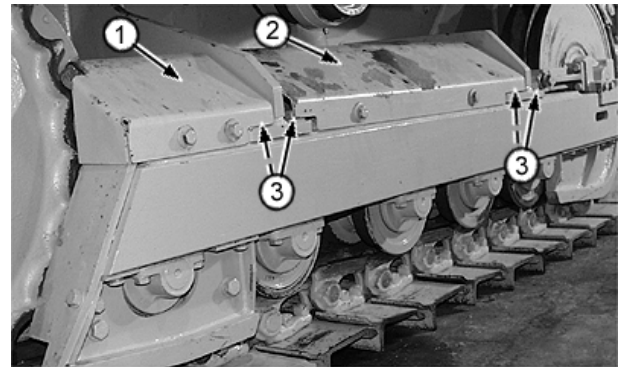

Continued on next page

LW86157.000011C -19-05JUN07-1/3

T118665B —UN—30NOV98

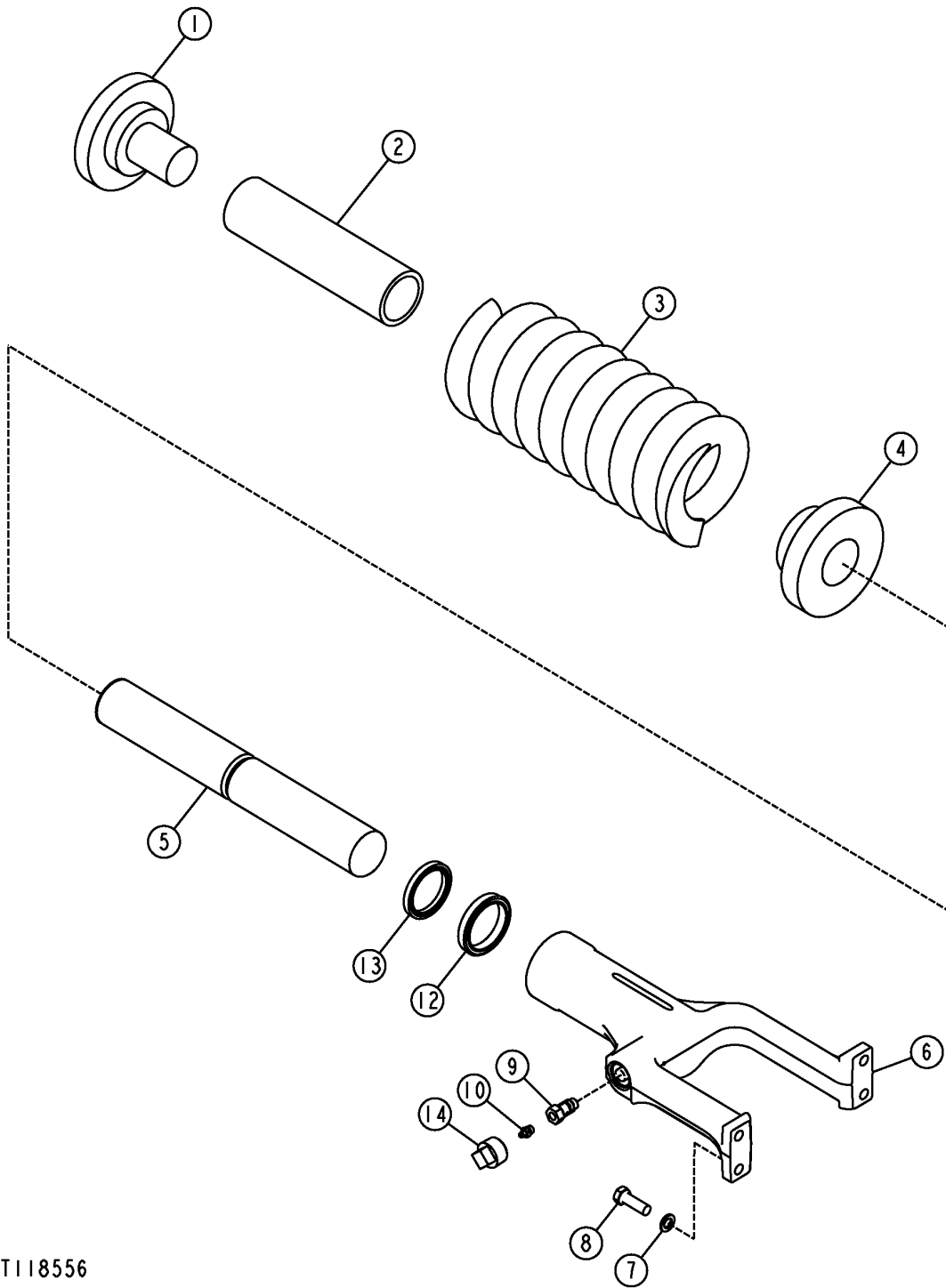

T118556

Track Tension Adjuster

T118556 —UN—23NOV98

Continued on next page

LW86157,000011C -19-05JUN07-2/3

## Track System

1— Cap  
2— Tube  
3— Compression Spring  
4— Cap (Front End)

5— Piston  
6— Yoke  
7— Washer (4 used)  
8— Cap Screw (4 used)

9— Check Valve  
10— Grease Fitting  
11— Not used  
12— Seal

13— Seal  
14— Plug

3. Remove track tension adjuster. See Track Tension Adjuster Remove and Disassemble. (Group 0130.)
4. Remove track idler recoil spring. See Track Idler Recoil Spring Remove and Install. (Group 0130.)
5. If necessary, disassemble track idler recoil spring. See Track Idler Recoil Spring Disassemble and Assemble. (Group 0130.)
6. Repair or replace parts as necessary.
7. If necessary, assemble track idler recoil spring. See Track Idler Recoil Spring Disassemble and Assemble. (Group 0130.)
8. Install track tension adjuster.
  - a. Inspect and clean all parts.
  - b. Install track idler recoil spring. See Track Idler Recoil Spring Remove and Install. (Group 0130.)
  - c. Install new scraper seal (13) and yoke seal (12).
  - d. Install track adjusting piston (5) in yoke (6).
  - e. If removed, install grease fitting (10).
  - f. Install adjuster assembly into track frame.
9. Install track frame. See Track Frame Remove and Install. (Group 0130.)
10. Install track. See Sealed Track Chain Installation. (Group 0130.) or see Lubricated Track Chain (Saw Tooth Master Split Link) Remove and Install. (Group 0130.)

LW86157,000011C -19-05JUN07-3/3

**Frame Wear Strips Remove and Install**

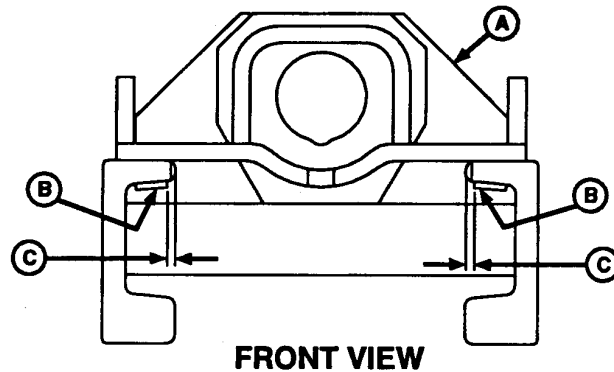

**FRONT VIEW**

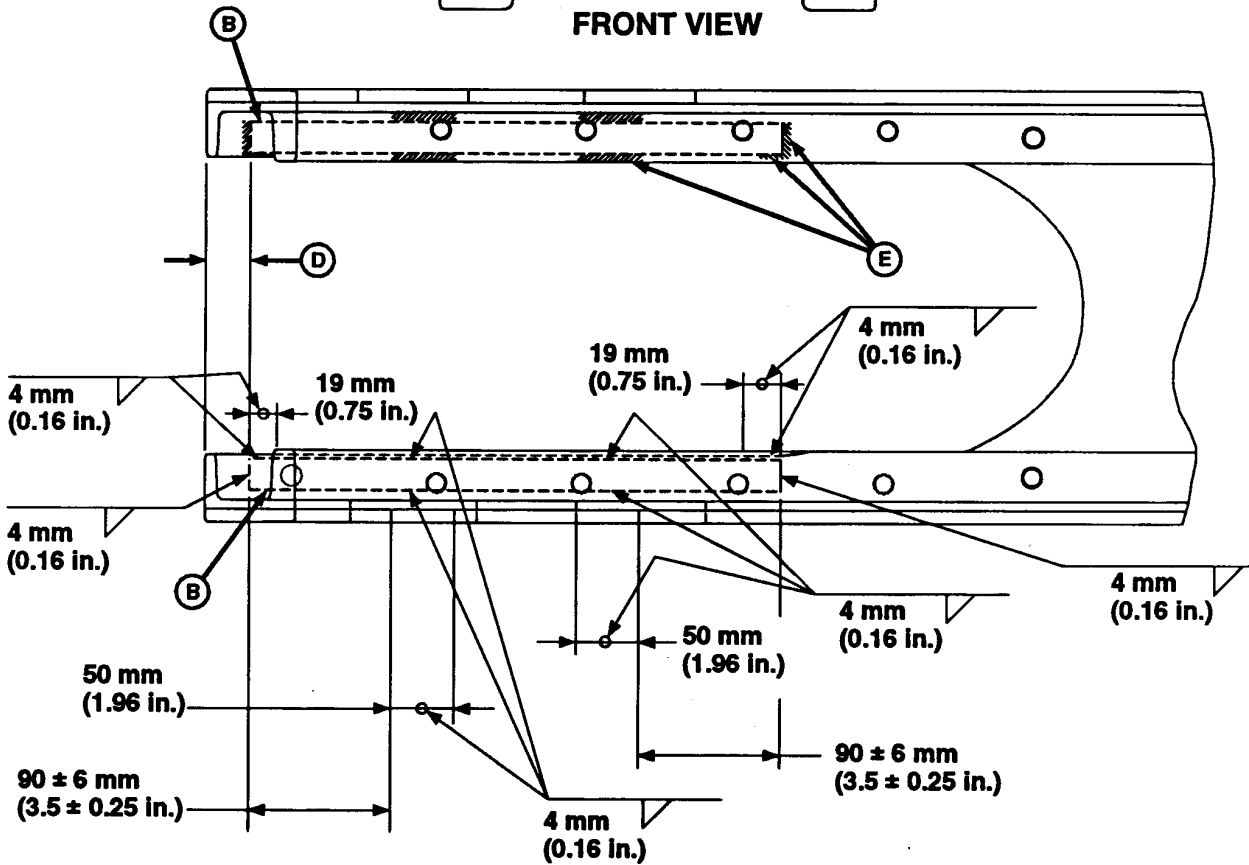

**BOTTOM VIEW**

A—Track Frame  
 B—Wear Strip (2 used)  
 C— $6 \pm 1.5$  mm ( $0.23 \pm 0.06$  in.)  
 D— $30.8$  mm ( $1.21$  in.)  
 E—Welded Areas

1. Remove front idler. See Front Idler Remove and Install. (Group 0130.)
2. Remove wear strips (B).
3. Grind track frame (A) wear strip surfaces smooth. Area must be free of any weld spatter.

**IMPORTANT: Good welds are important. Have only a qualified welder do the procedure. Use E7018 electrodes.**

**Before welding, clean all dirt and paint from the weld areas and turn battery disconnect switch to OFF. Connect the welder ground clamp close to each weld area so electrical current does not pass through any bearings.**

4. If track frame is still on machine, make sure the battery disconnect switch is turned to the OFF position.

Continued on next page

CEDEX547,103 -19-01JUN04-1/2

T8058AH—UN—13SEP93

*Track System*

5. Clamp wear strip in position, using dimensions (C and D).
6. Weld each wear strip in eight places as indicated using E7018 electrodes.
7. Install and adjust front idler. See Front Idler Remove and Install. (Group 0130.)  
See Front Idler Adjustment. (Group 0130.)

CED,OUTX547,103 -19-01JUN04-2/2

*Track System*

**Section 02  
Axles and Suspension Systems**

**Contents**

Page

**Group 0201—Drive Axle Housing and Support**  
Final Drive Remove and Install..... 02-0201-1

**Group 0250—Axle Shaft, Bearings, and  
Reduction Gear**  
Final Drive Disassemble and  
Assemble..... 02-0250-1

*Contents*

# Group 0201 Drive Axle Housing and Support

## Final Drive Remove and Install

1. Disconnect track chain. See Lubricated Track Chain (Saw Tooth Master Split Link) Remove and Install. (Group 0130.)
2. Remove hydrostatic motor. See Hydrostatic Motor Remove and Install. (Group 0300.)
3. Raise rear of machine using a 89 000 N (10-ton) floor jack and block securely.

**CAUTION:** The approximate weight of sprocket is 59 kg (130 lb).

### Final Drive—Specification

Sprocket—Weight..... 59 kg Approximate  
130 lb Approximate

4. Remove cover (1), outer guard (2) and inner guard (4). Attach a C-clamp and a hoist to sprocket. Remove cap screws (3) and sprocket.

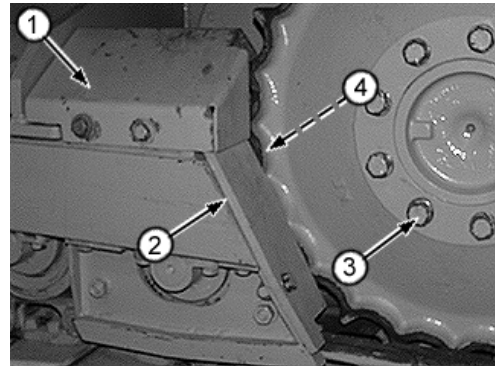

450J Shown

1— Cover  
2— Outer Guard

3— Cap Screws  
4— Inner Guard

T118793B —UN—11DEC98

TE14778,0000023 -19-22APR04-1/7

5. Install DFT1063 Final Drive Lift Bracket (1), DFT1166 Final Drive Lifting Bracket Adapter (2), and for 450J machines DFT1167 Final Drive Lifting Bracket Adapter Spacer (3) on final drive. See DFT1063 Final Drive Lift Bracket. (Group 9900.) See DFT1166 Final Drive Lifting Bracket Adapter. (Group 9900.) See DFT1167 Final Drive Lifting Bracket Adapter Spacer. (Group 9900.)

1— Final Drive Lifting Bracket      3— Lifting Bracket Adapter  
2— Lifting Bracket Adapter        Spacer (450J only)

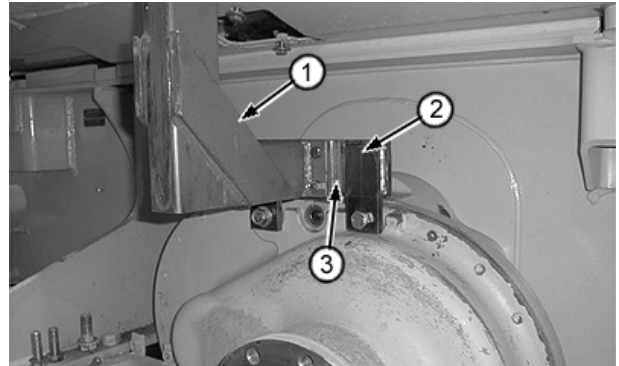

450J Shown

T118794B —UN—11DEC98

TE14778,0000023 -19-22APR04-2/7

6. Remove cap screws (1).

1— Cap Screw (5 used)

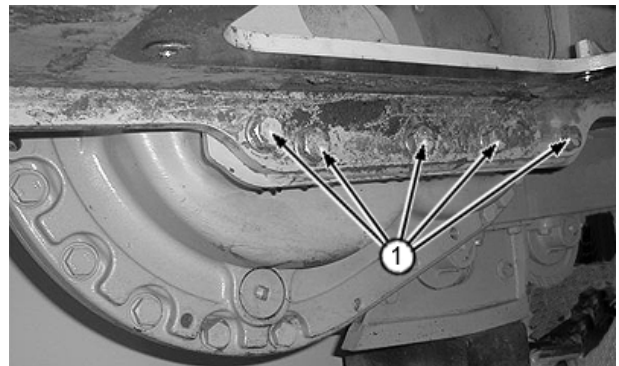

T118795B —UN—11DEC98

Continued on next page

TE14778,0000023 -19-22APR04-3/7

## Drive Axle Housing and Support

7. Disconnect park brake hose (1).

**⚠ CAUTION: The approximate weight of final drive is 340 kg (750 lb).**

### Final Drive—Specification

Final Drive—Weight..... 340 kg Approximate  
750 lb Approximate

8. Remove 11 cap screws (2). Remove final drive assembly.

1—Park Brake Hose                      2—Cap Screw (11 used)

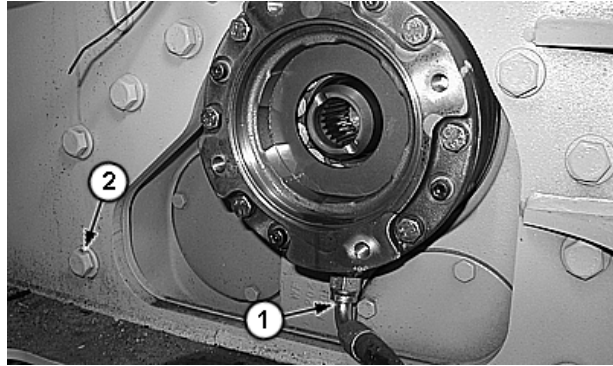

T199300A—UN—16APR04

TE14778,0000023 -19-22APR04-4/7

9. Clean all mating surfaces of final drive.  
10. Apply form in place gasket to surface of final drive and attaching hardware.  
11. Install final drive assembly.  
12. Connect park brake hose (1).  
13. Install cap screws (2).

1—Park Brake Hose                      2—Cap Screw (11 used)

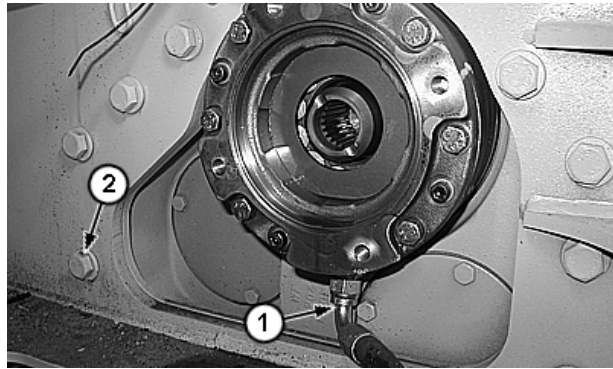

T199300A—UN—16APR04

TE14778,0000023 -19-22APR04-5/7

14. Install cap screws (1).

1—Cap Screw (5 used)

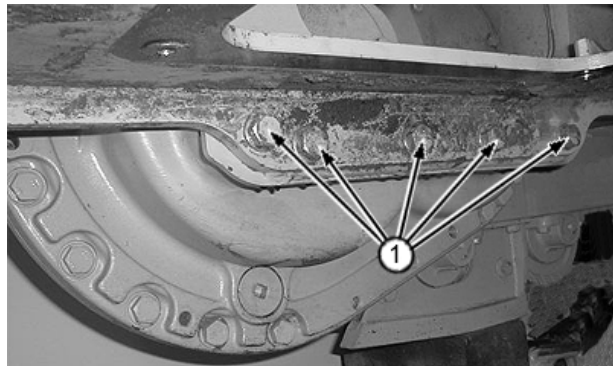

T118795B—UN—11DEC98

Continued on next page

TE14778,0000023 -19-22APR04-6/7

Drive Axle Housing and Support

15. Install inner guard (4), sprocket and cap screws (3), outer guard (2) and cover (1).
16. Install hydrostatic motor. See Hydrostatic Motor Remove and Install.(Group 0300.)
17. Connect track chain. See Lubricated Track Chain (Saw Tooth Master Split Link) Remove and Install. (Group 0130.)

1— Cover  
2— Outer Guard

3— Cap Screws (9 used)  
4— Inner Guard

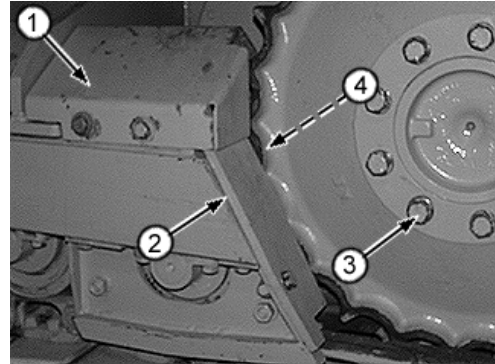

450J Shown

T118793B —UN—11DEC98

TE14778.0000023 -19-22APR04-7/7

*Drive Axle Housing and Support*

# Group 0250 Axle Shaft, Bearings, and Reduction Gear

## Final Drive Disassemble and Assemble

NOTE: 450J shown unless otherwise indicated.

NOTE: The approximate capacity of each final drive is 8.5 L (9 qt).

1. Drain oil from final drive.

**CAUTION:** Final drive assembly weighs approximately 340 kg (750 lbs). Use proper lifting equipment and safety precautions. Failure to do so may cause personal injury.

### Final Drive—Specification

Final Drive	
Assembly—Weight.....	340 kg Approximate (750 lb) Approximate

2. Block and support final drive on heavy-duty bench.
3. Remove park brake assembly. See Park Brake Remove and Install. (Group 1100.)

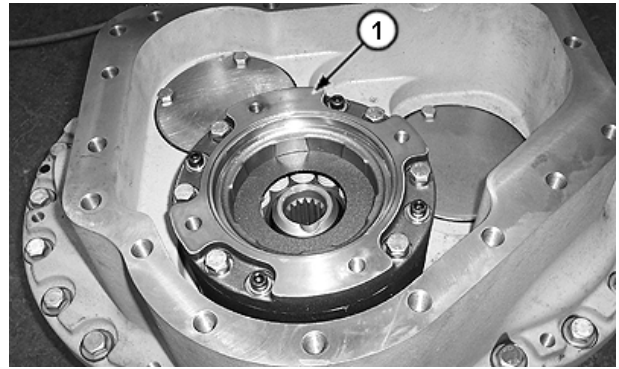

T199297A —UN—10MAY04

TE14778,0000024 -19-20JAN09-1/25

4. Remove axle shaft cover (1) and second idler pinion gear cover (2).

1— Axle Shaft Cover

2— Second Idler Pinion Gear Cover

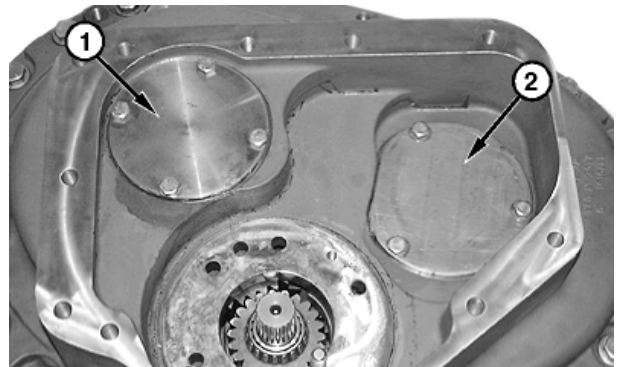

T199777A —UN—10MAY04

TE14778,0000024 -19-20JAN09-2/25

5. Remove cap screws (3), retaining plate (1) and shims (2).

1— Retaining Plate  
2— Shims

3— Cap Screws (3 used)

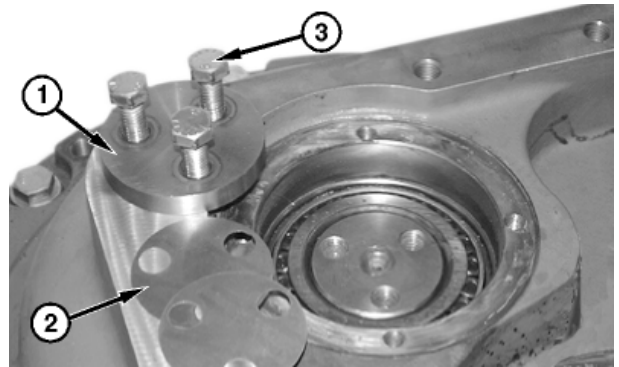

T199779A —UN—10MAY04

Continued on next page

TE14778,0000024 -19-20JAN09-3/25

## Axle Shaft, Bearings, and Reduction Gear

6. Remove housing cap screws (1).
7. Remove housing alignment dowel pins (2).

**NOTE:** The axle shaft inner bearing cone is pressed into the housing. Jack screws are needed to pull housing with bearing cone from shaft. Turn jack screws equally while separating housing halves.

8. Separate housing halves by installing jack screws (3).
9. Remove O-ring (4).

1— Cap Screws (24 used)      3— Jack Screws (4 used)  
2— Dowel Pins (2 used)      4— O-Ring

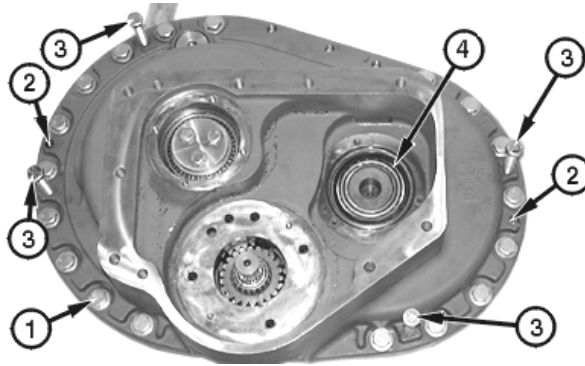

T1199780A —UN—10MAY04

TE14778,0000024 -19-20JAN09-4/25

10. Remove snap ring (1) from axle shaft.

1— Snap Ring

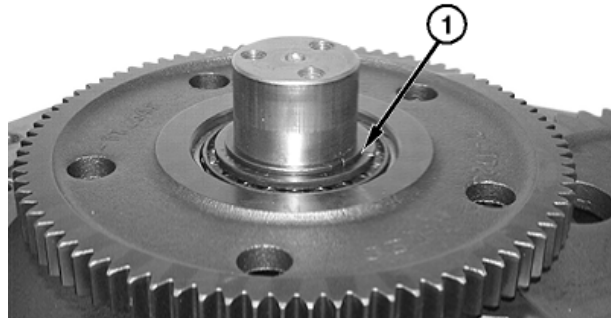

T118848B —UN—11DEC98

TE14778,0000024 -19-20JAN09-5/25

11. Remove first idler cluster gear (1) with bearing.

1— First Idler Cluster Gear



T118849B —UN—23DEC98

Continued on next page

TE14778,0000024 -19-20JAN09-6/25

## Axle Shaft, Bearings, and Reduction Gear

**NOTE:** Remove second idler ring and pinion gear assembly with final drive gear partially pulled up axle shaft.

12. Remove final drive gear (3) with bearing (1) and spacer (2).
13. Remove final drive gear spacer from axle shaft.
14. Lift housing half (4) off of axle shaft.

1— Bearing  
2— Spacer

3— Gear  
4— Housing Half

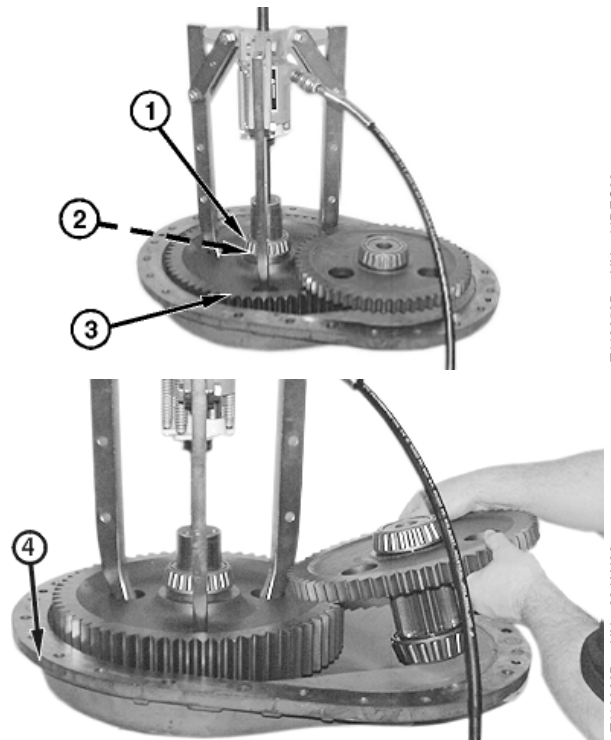

T118850B —UN—11DEC98

T119800B —UN—22JAN99

TE14778,0000024 -19-20JAN09-7/25

15. Remove bearing (1) from axle shaft.
16. Remove and discard seal assembly (2).
17. Clean and inspect housing and parts.

1— Bearing

2— Seal

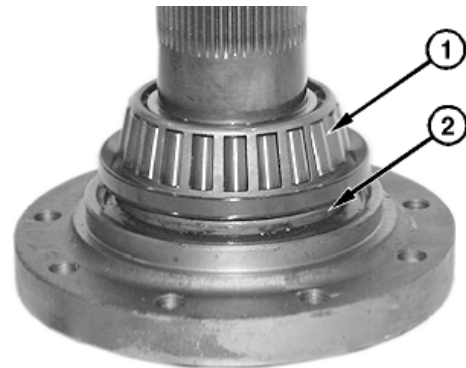

T118852B —UN—11DEC98

Continued on next page

TE14778,0000024 -19-20JAN09-8/25

Axle Shaft, Bearings, and Reduction Gear

18. Remove parts (2—6) as shown.
19. Inspect final drive input gear (4) and bearing cones (3 and 5). Replace as necessary.
20. Install bearing cup (2) into brake housing.
21. Install bearing cup (6) into housing half (7).
22. Install bearing cones (3 and 5) onto final drive input gear (4).

- |                           |                 |
|---------------------------|-----------------|
| 1— Brake Housing          | 5— Bearing Cone |
| 2— Bearing Cup            | 6— Bearing Cup  |
| 3— Bearing Cone           | 7— Housing      |
| 4— Final Drive Input Gear |                 |

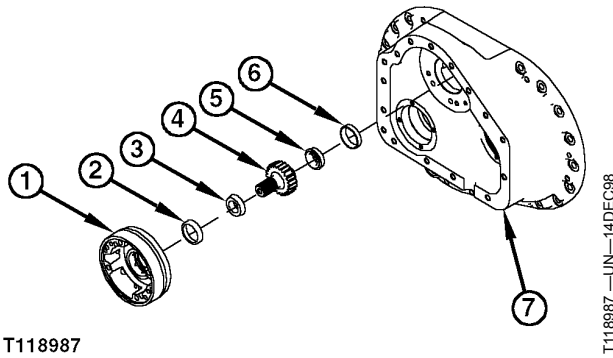

T118987

T118987 —JUN—14DEC98

TE14778,0000024 -19-20JAN09-9/25

23. Remove parts (1—4) as shown.
24. Inspect second idler pinion gear (3) and bearing cones (1 and 4). Replace as necessary.
25. Install bearing cones (1 and 4) onto second idler pinion gear (3).

- |                           |                             |
|---------------------------|-----------------------------|
| 1— Bearing Cone           | 3— Second Idler Pinion Gear |
| 2— Second Idler Ring Gear | 4— Bearing Cone             |

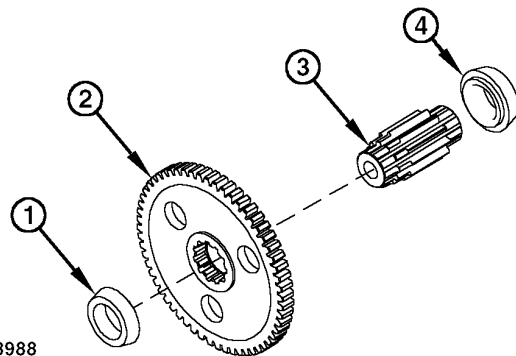

T118988

T118988 —JUN—14DEC98

TE14778,0000024 -19-20JAN09-10/25

*NOTE: A snap ring, located in the center of the cluster gear bore, is used to provide proper spacing for bearing cups in assembly.*

26. Remove bearing cups (1 and 4) from first idler cluster gear (3).
27. Install bearing cups (1 and 4) into the first idler cluster gear (3). Seat bearing cups on snap ring.

- |                |                             |
|----------------|-----------------------------|
| 1— Bearing Cup | 3— First Idler Cluster Gear |
| 2— Snap Ring   | 4— Bearing Cup              |

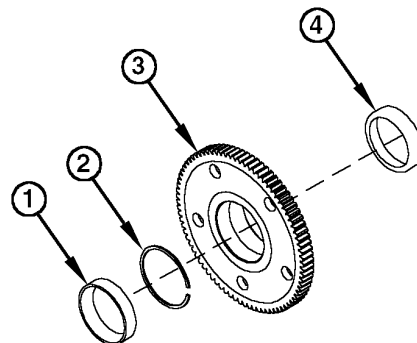

T118989

T118989 —JUN—14DEC98

Continued on next page

TE14778,0000024 -19-20JAN09-11/25

## Axle Shaft, Bearings, and Reduction Gear

28. Remove final drive axle bearing cup (2) and second pinion outer bearing cup (3) from final drive housing (1).
29. Install final drive axle bearing cup (2) and second pinion outer bearing cup (3) into final drive housing (1). Fully seat bearing cups in bottom of bores.

1— Housing  
2— Final Drive Axle Bearing Cup

3— Second Pinion Outer Bearing Cup

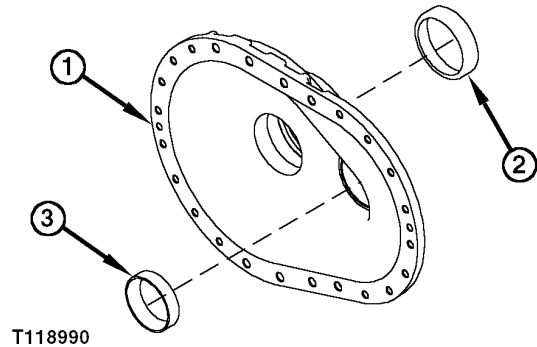

T118990

T118990—UN—14DEC98

TE14778,0000024 -19-20JAN09-12/25

30. Clean seal rubber rings and all surfaces that contact rubber rings with a non-petroleum based solvent. Thoroughly dry parts and surfaces using a lint-free tissue.
31. Install seal assembly (2) onto axle shaft (3).
32. Install bearing cone (1) onto axle shaft (3), tight against shoulder.

1— Bearing Cone  
2— Seal

3— Axle Shaft

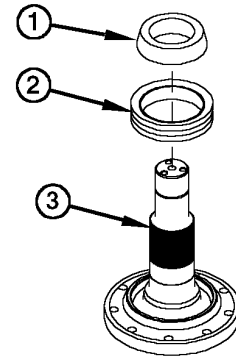

T118986

T118986—UN—14DEC98

TE14778,0000024 -19-20JAN09-13/25

**IMPORTANT: Special tool JDG1266 Final Drive Seal Protector centers axle in housing during installation. Failure to use the tool will result in a torn or damaged seal assembly.**

33. Install special tool (1) JDG1266 in bore of housing.
34. Place axle shaft assembly (2) on level surface.
35. Lower housing (3) onto axle shaft assembly (2).

*NOTE: Axle shaft and housing must be square and level for assembly.*

36. With the weight of the housing on the axle flange, block and support housing using a level.
37. Disconnect hoist and remove special tool (1).

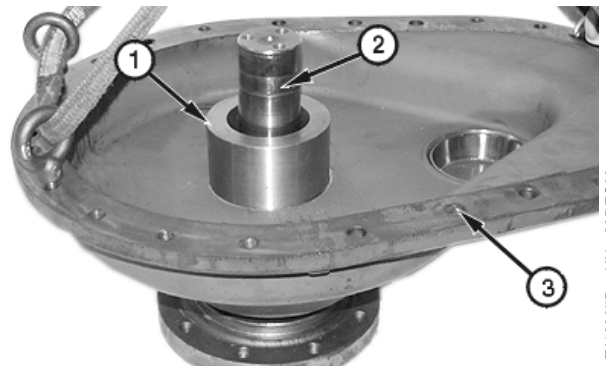

1— JDG1266 Final Drive Seal Protector  
2— Axle Shaft Assembly  
3— Housing

T118867B—UN—23DEC98

Continued on next page

TE14778,0000024 -19-20JAN09-14/25

Axle Shaft, Bearings, and Reduction Gear

38. Install final drive gear spacer (1) onto axle shaft.

1—Final Drive Gear Spacer

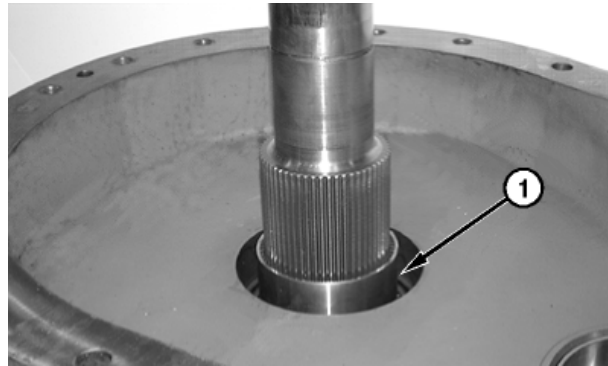

T118854B —UN—11DEC98

TE14778,0000024 -19-20JAN09-15/25

*NOTE: Install second idler pinion gear assembly (2) after final drive gear (1) is lowered halfway into position.*

39. Install final drive gear (1).

1—Final Drive Gear

2—Second Idler Pinion Gear Assembly

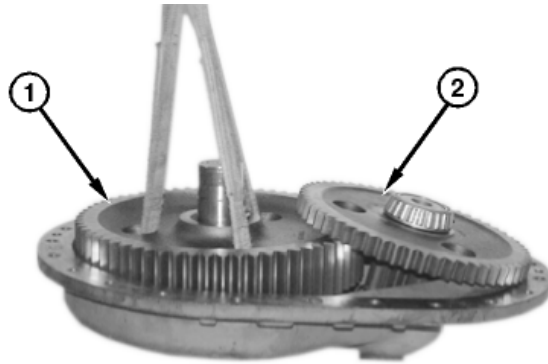

T118855B —UN—11DEC98

Continued on next page

TE14778,0000024 -19-20JAN09-16/25

**⚠ CAUTION: DO NOT heat oil over 182°C (360°F). Oil fumes or oil can ignite above 193°C (380°F). Use a thermometer. DO NOT allow flame or heater element to come in direct contact with the oil. Heat oil in a well ventilated area.**

40. Install spacer (1) onto axle shaft with chamfer side toward gear.
41. Heat bearing cone (2) and install onto axle shaft above spacer (1).

1— Spacer

2— Bearing Cone

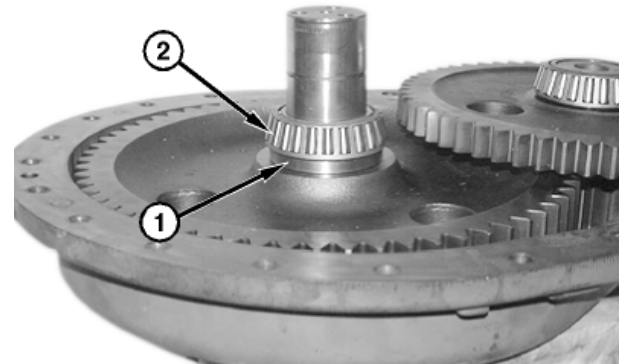
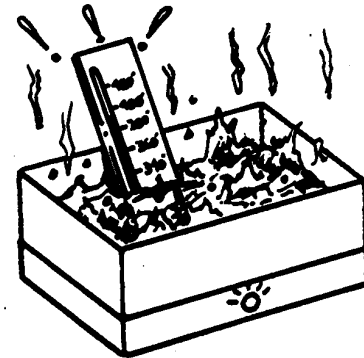

T81191 —UN—23FEB89

T118856B —UN—11DEC98

TE14778.0000024 -19-20JAN09-17/25

42. Install first idler cluster gear (1).
43. Heat bearing cone (2) and install onto axle shaft.
44. Install snap ring (3) onto axle shaft.

Select the appropriate snap ring (3) by checking end play on first idler cluster gear and compare to following specifications.

**Final Drive—Specification**

Final Drive First Idler	
Cluster Gear—End Play.....	0—0.228 mm
	0—0.009 in.

1— First Idler Cluster Gear  
2— Bearing Cone

3— Snap Ring

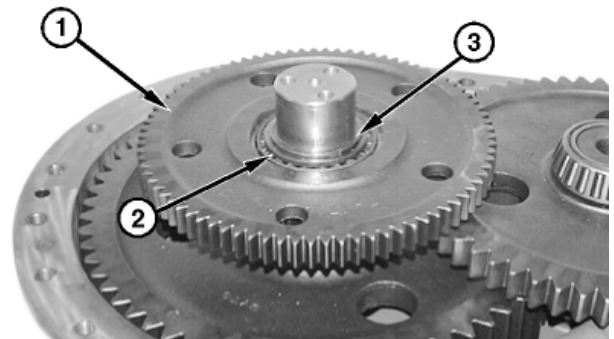

T118857B —UN—11DEC98

Continued on next page

TE14778.0000024 -19-20JAN09-18/25

- 45. Install housing alignment dowel pins (1) in housing half.
- 46. Apply cure primer and plastic gasket to housing sealing surface.
- 47. Join housing halves.
- 48. Install cap screws and tighten evenly to specifications.

**Final Drive—Specification**

Final Drive Housing Cap	
Screws—Initial Torque.....	135 N·m 100 lb-ft
Final Torque.....	320 N·m 235 lb-ft

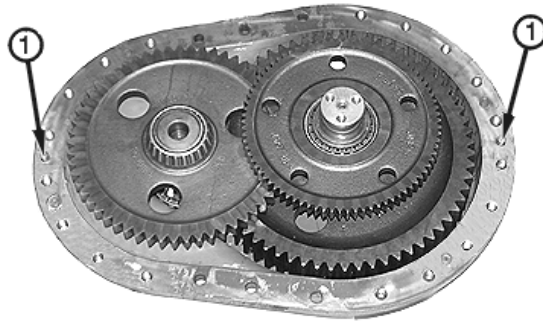

T119802B —UN—25JAN99

1—Dowel Pins (2 used)

TE14778,0000024 -19-20JAN09-19/25

- 49. Seat bearing cup (1) onto bearing cone.

1—Bearing Cup

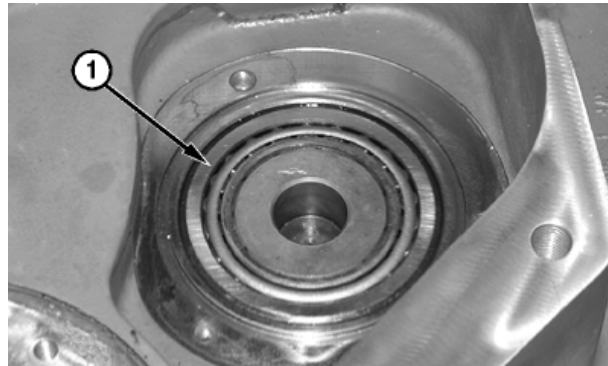

T199786A —UN—11MAY04

Continued on next page

TE14778,0000024 -19-20JAN09-20/25

50. Measure distance between housing and bearing cone.  
Add shims (1) to achieve specified preload-end play.

**Final Drive—Specification**

Final Drive Pinion  
Shaft—Preload-End  
Play..... 0.025 mm preload—0.152 mm end play  
0.001 in. preload—0.005 in. end play

51. Install O-ring (2).

52. Install cover with three cap screws (4) and tighten to specifications.

**Final Drive—Specification**

Final Drive Pinion  
Shaft Cover Cap  
Screws—Torque..... 80 N·m  
60 lb·ft

1— Shims  
2— O-Ring

3— Cover  
4— Cap Screw (3 used)



T199781A —UN—10MAY04

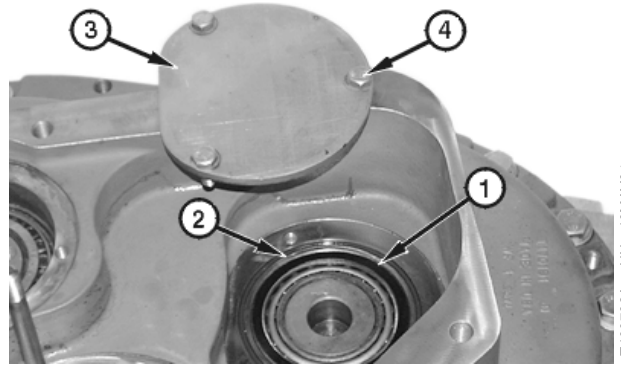

T199782A —UN—10MAY04

Continued on next page

TE14778,0000024 -19-20JAN09-21/25

**CAUTION: DO NOT** heat oil over 182°C (360°F). Oil fumes or oil can ignite above 193°C (380°F). Use a thermometer. **DO NOT** allow flame or heater element to come in direct contact with the oil. Heat oil in a well ventilated area.

*NOTE: Housing and axle shaft flange must be level, with weight of housing on axle flange.*

- 53. Heat bearing and install onto axle shaft.
- 54. Install shims (2) removed initially, and add an additional 0.508 mm (0.020 in.) shims to provide an end play on axle shaft.
- 55. Install retaining plate (1).
- 56. Tighten retaining plate cap screws to specification (3).

**Final Drive—Specification**

Retaining Plate Cap	
Screws—Torque.....	156 N-m 115 lb-ft

- 57. Attach final drive housing to a hoist.
- 58. Lift final drive and rotate axle and tap on retaining cap with hammer and punch. Torque cap screws again to specification. Repeat this step until cap screws do not turn when tightened after tapping retainer plate.

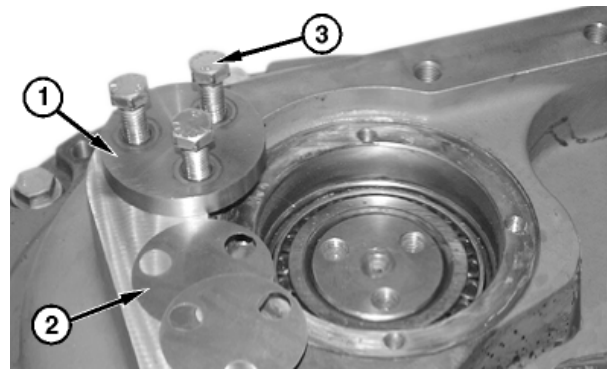
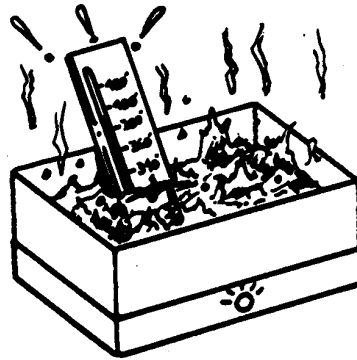

1— Retaining Plate  
2— Shims  
3— Cap Screws (3 used)

TE14778,0000024 -19-20JAN09-22/25

T81191 —UN—23FEB89

T199779A —UN—10MAY04

- 59. Place dial indicator at the exact center of retaining cap as shown and adjust to zero.
- 60. Lower final drive assembly until axle shaft flange is on a level surface with weight of final drive housing on axle flange and bearing. Loosen hoist chains, balance and rotate final drive housing by hand. Record indicator maximum reading.
- 61. The maximum dial indicator reading will be the axle shaft bearing end play.
- 62. Remove retaining plate and adjust shims as required to obtain specified axle shaft preload.

**Final Drive—Specification**

Final Drive Axle Shaft	
Preload—Preload.....	0.05 mm—0.155 mm 0.002—0.006 in.

- 63. Apply cure primer and plastic gasket to retaining plate cap screws and tighten to specifications.

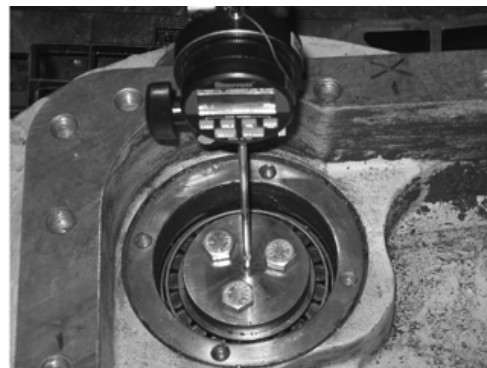

**Final Drive—Specification**

Final Drive Axle Shaft	
Retaining Plate Cap	
Screws—Torque.....	156 N-m 115 lb-ft

Continued on next page

TE14778,0000024 -19-20JAN09-23/25

TX1054194A —UN—14JAN09

Axle Shaft, Bearings, and Reduction Gear

64. Apply cure primer and plastic gasket to axle shaft cover plate (1). Install cover and tighten cap screws to specifications.

**Final Drive—Specification**

Final Drive Axle Shaft	
Cover Plate Cap	
Screws—Torque.....	80 N·m
	60 lb·ft

1— Cover Plate

2— Cap Screws (4 used)

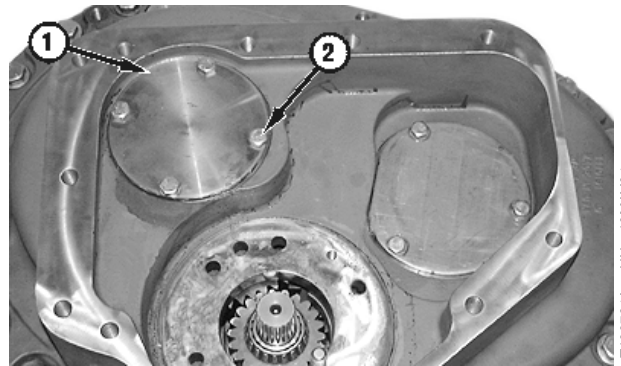

T199784A —JUN—10MAY04

TE14778.0000024 -19-20JAN09-24/25

65. Install park brake assembly. See Park Brake Remove and Install. (Group 1100.)

**CAUTION:** Use only regulated, compressed air of 34.5 kPa (0.345 bar) (5 psi) maximum to check seal on final drive housing. If high pressure compressed air is used, premature case seal failure can occur.

**Wear proper face and body protection when using compressed air.**

66. Install a 0—15 psi gauge and shut-off valve in the housing oil fill hole.
67. Using a regulated air source, apply a maximum of 34.5 kPa (0.345 bar) (5 psi) to case and close shut-off valve.

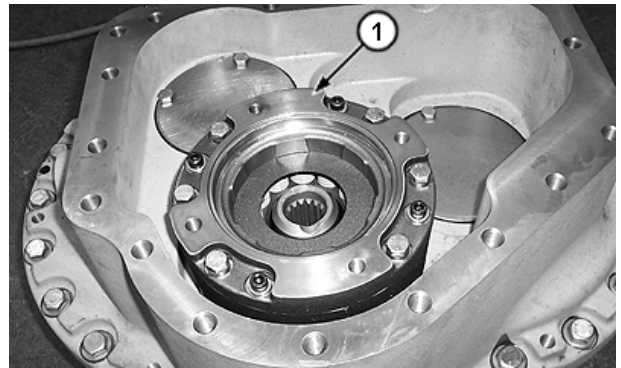

T199297A —JUN—10MAY04

68. Observe pressure gauge for five minutes. If any pressure drop occurs, the housing must be checked for leaks and resealed.

TE14778.0000024 -19-20JAN09-25/25

*Axle Shaft, Bearings, and Reduction Gear*

## Section 03 Transmission

### Contents

	Page
<b>Group 0300—Removal and Installation</b>	
Hydrostatic Pump Remove and Install .....	03-0300-1
Hydrostatic Motor Remove and Install .....	03-0300-10
<b>Group 0315—Controls Linkage</b>	
Transmission Control Lever (TCL) Remove and Install.....	03-0315-1
Transmission Control Lever (TCL) Disassemble and Assemble (S.N. —130885).....	03-0315-2
<b>Group 0360—Hydrostatic System</b>	
Hydrostatic Pumps Disassemble .....	03-0360-1
Hydrostatic Charge Pump Disassemble and Assemble .....	03-0360-9
Pump Displacement Control Valve (PDCV) Disassemble and Assemble .....	03-0360-14
Multi-Function Valve Disassemble and Assemble .....	03-0360-16
Neutral Charge Relief Valve Disassemble and Assemble .....	03-0360-17
Hydrostatic Pump Assemble .....	03-0360-18
Hydrostatic Motor Disassemble.....	03-0360-26
Hydrostatic Motor Assemble.....	03-0360-32
Oil Cooler Thermal Bypass Valve Remove and Install.....	03-0360-44
Hydrostatic Filter Remove and Install .....	03-0360-44
Hydrostatic Filter Disassemble and Assemble .....	03-0360-46
Hydrostatic Reservoir Remove and Install .....	03-0360-47

*Contents*

## Hydrostatic Pump Remove and Install

**⚠ CAUTION:** Prevent possible injury from unexpected track movement. Raise the machine off the ground and support with blocks. Tracks **MUST** be free to rotate in either direction to perform Hydrostatic Pump Initial Startup Procedure and Pump Displacement Control Valve Neutral (Null) Adjustment.

1. Raise machine off the ground and support with blocks. Lower blade to ground. Tracks **MUST** be free to rotate in either direction.

2. Turn battery disconnect switch to OFF.

*NOTE: The approximate capacity of hydrostatic reservoir is 43 L (11.3 gal).*

3. Remove access plate from bottom of hydrostatic reservoir compartment and drain reservoir.

*NOTE: The approximate capacity of engine coolant is 11.3 L (3 gal).*

4. If equipped with heater, drain engine coolant.

5. Remove floor mat and floor access plate.

6. For machines with toolbox, pull out drawer and remove cap screw holding toolbox in place. Remove toolbox from machine.

7. Remove four cap screws (A) from around seat box bottom.

8. Remove shoulder cap screws (C) from seat box under armrest (B) on both sides of seat.

9. Remove two cap screws from knee pad (E) on both sides of seat.

**IMPORTANT:** Observe control levers as seat is being raised or lowered for possible interference.



T116758B —UN—03SEP98

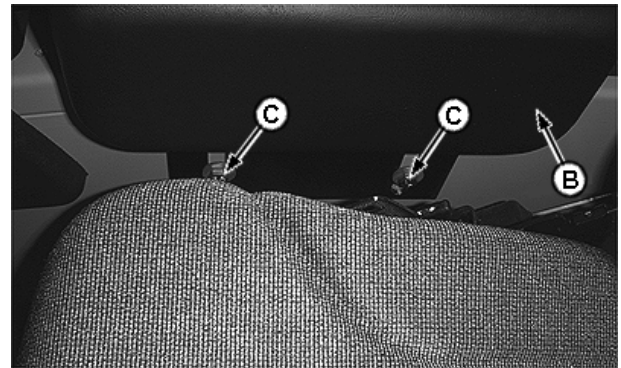

T116757B —UN—21AUG98

**A**—Cap Screws Around Seat Box Bottom (4 used)  
**B**—Armrest

**C**—Shoulder Cap Screws (2 used)  
**E**—Knee Pad

10. Loosen jam nut on hydraulic control lever tee handle and index handle 90° to provide clearance for seat when tilting.

11. On units equipped with rear screen or cab, tilt back of seat forward.

CED, TX03399, 5046 -19-04DEC09-1/13

12. Tilt seat up as far as possible with jack screw (D) located in left rear corner of seat box.

**D**—Jack Screw

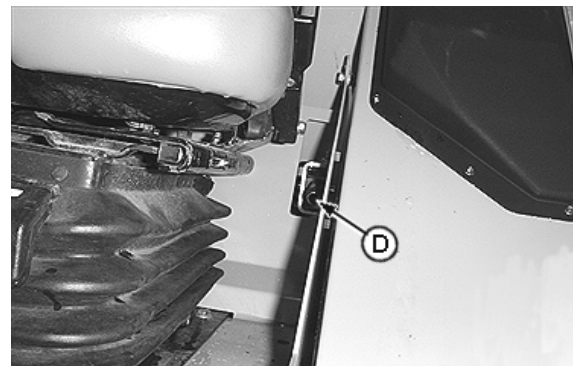

T200435A —UN—27MAY04

Continued on next page

CED, TX03399, 5046 -19-04DEC09-2/13

Removal and Installation

13. Disconnect blower harness connector (1) and heater hoses (2 and 3).

14. Remove heater assembly.

- 1—Blower Harness Connector
- 2—Heater Hose
- 3—Heater Hose

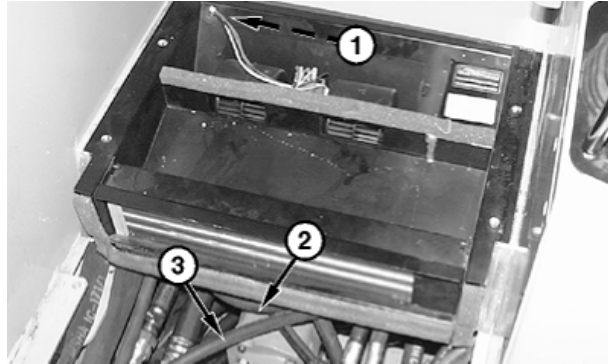

T1188398 —UN—10DEC98

CED,TX03399,5046 -19-04DEC09-3/13

15. Disconnect engine harness connectors (1 and 2) and transmission harness connector (3).

16. Disconnect engine harness connector (1) from bracket.

17. Loosen hose clamps (4) from heater valve and disconnect heater valve from bracket. (Do not disconnect hoses from heater valve).

18. Remove cap screws (5) from bracket and move bracket, wiring and hoses off to side.

- 1—Engine Harness Connector
- 2—Engine Harness Connector
- 3—Transmission Harness Connector
- 4—Heater Valve Clamp (Cab units only) (2 used)
- 5—Bracket Cap Screw (2 used)

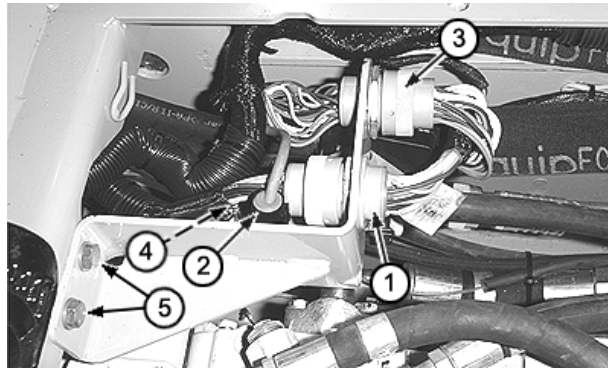

T200959A —UN—16JUN04

Continued on next page

CED,TX03399,5046 -19-04DEC09-4/13

## Removal and Installation

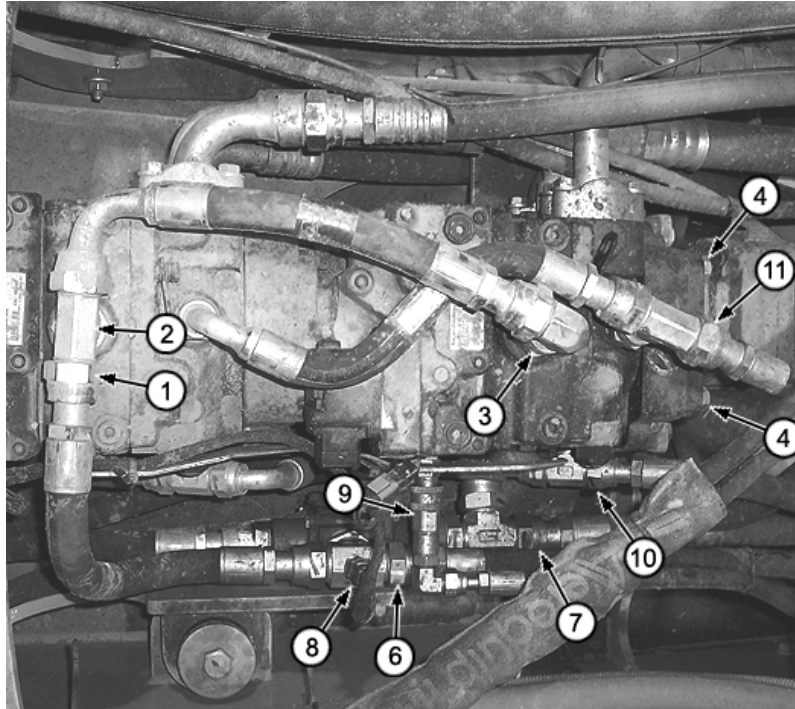

- 1—Line (Front Pump Tee Fitting-to-Cooler Bypass Valve)
- 2—Tee Fitting (Front Pump)
- 3—Line Fitting (Rear Pump)

- 4—Hydraulic Pump Mounting Cap Screws (4 used)
- 5—Not Used
- 6—Line (Oil Cooler Bypass Valve-to-Reservoir)

- 7—Line (Left Motor Tee Fitting-to-Oil Cooler Bypass Valve)
- 8—Oil Cooler Bypass Valve Wire Terminal
- 9—Line (Park Brake)

- 10—Line (Oil Filter-to-Charge Pump)
- 11—Line (Charge Pump-to-Oil Filter)

**⚠ CAUTION:** To avoid injury from escaping fluid under pressure, stop engine and relieve the pressure in the system before disconnecting or connecting hydraulic or other lines. Tighten all connections before applying pressure.

- 19. Disconnect line (1). Close all openings using caps and plugs.

20. Disconnect fittings (2 and 3) and remove line.

21. Disconnect lines (6, 7, 9, and 10).

22. Disconnect wire terminal (8).

23. Remove cap screws (4) from hydraulic pump and remove pump. Set pump aside.

Continued on next page

CED, TX03399, 5046 -19-04DEC09-5/13

TZ00359A—UN—26MAY04

Removal and Installation

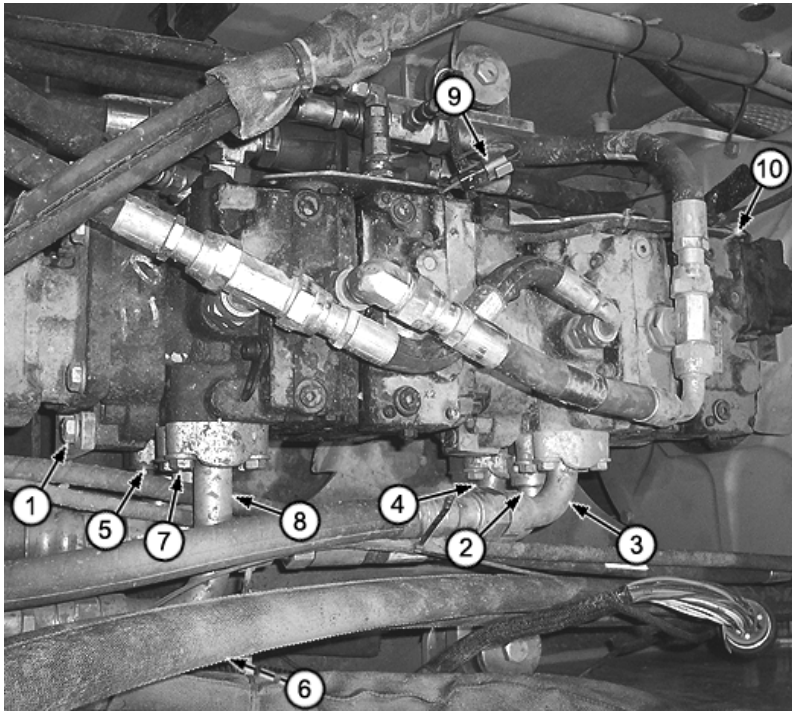

T200360A—UN—26MAY04

- |  |  |   |   |
|--|--|---|---|
| 1—Hydrostatic Pump-to-Rear Mount Bracket Cap Screws (2 used)   | 4—Line (Front Pump Forward Outlet Port-to-R.H. Motor “A” Port) | 7—Tee-Fitting   | 10— Front Pressure Control Pilot (PCP) Wiring Connector |
| 2—Line (Front Charge Pump-to-Rear Charge Pump Tee-Fitting)     | 5—Line (Rear Pump Forward Outlet Port-to-L.H. Motor “B” Port)  | 8—Line (Rear Pump Reverse Outlet Port-to-L.H. Motor “A” Port) |   |
| 3—Line (Front Pump Reverse Outlet Port-to-R.H. Motor “B” Port) | 6—Rear Pump Mount Bracket-to-Frame Cap Screws (4 used)         | 9—Rear Pressure Control Pilot (PCP) Wiring Connector          |   |

24. Disconnect lines (2—5, 7 and 8). Close all openings using caps and plugs.

26. Remove cap screws (1 and 6) and remove rear pump mounting bracket.

For ease of removal and installation of pumps, lines can be tied together and pulled up and out of the way.

25. Disconnect pressure control pilot (PCP) wiring connectors (9 and 10).

Continued on next page

CED, TX03399, 5046 -19-04DEC09-6/13

## Removal and Installation

27. Drill and tap two 1-1/16 plugs to accommodate a 1/2 in. eye bolt.

Remove pump fittings and install eyebolts as shown.

28. Connect hydrostatic pumps to hoist using chains, DFT1063 Lifting Bracket, and DFT1130 Adapter. See DFT1063 Pump Lifting Bracket. (Group 9900.) See DFT1130 Adapter. (Group 9900.)

**CAUTION:** The approximate weight of the hydrostatic pump assembly is 120 kg (265 lb).

### Hydrostatic Pump—Specification

Dual Hydrostatic Pump

Assembly—Weight..... 120 kg Approximate  
265 lb Approximate

29. Remove flywheel housing cover cap screws and pull pumps back far enough for dampener hub to clear flywheel dampener.

Place a wood block under rear pump and lower pumps to rest on frame.

Disconnect rear chain, shorten and reconnect to lift pumps out at approximate 45 degree angle.

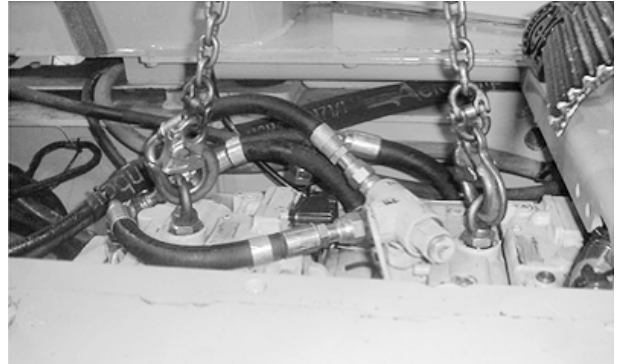

T118456A —UN—10DEC98

30. Carefully remove pumps from left side of machine, flywheel housing plate first. The best clearance is achieved close to the floor, passing through the recess in console frame.

31. Remove hydraulic lines and fittings from pumps.

Tag lines and mark orientation of fittings to aid in reassembly.

CED,TX03399,5046 -19-04DEC09-7/13

32. Remove cap screws (1) joining the two pumps and separate pumps.

1— Socket Head Cap Screw (4 used)

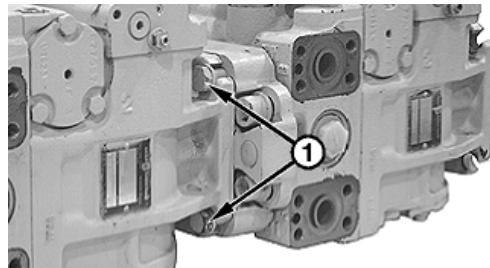

T118271B —UN—08JAN99

Continued on next page

CED,TX03399,5046 -19-04DEC09-8/13

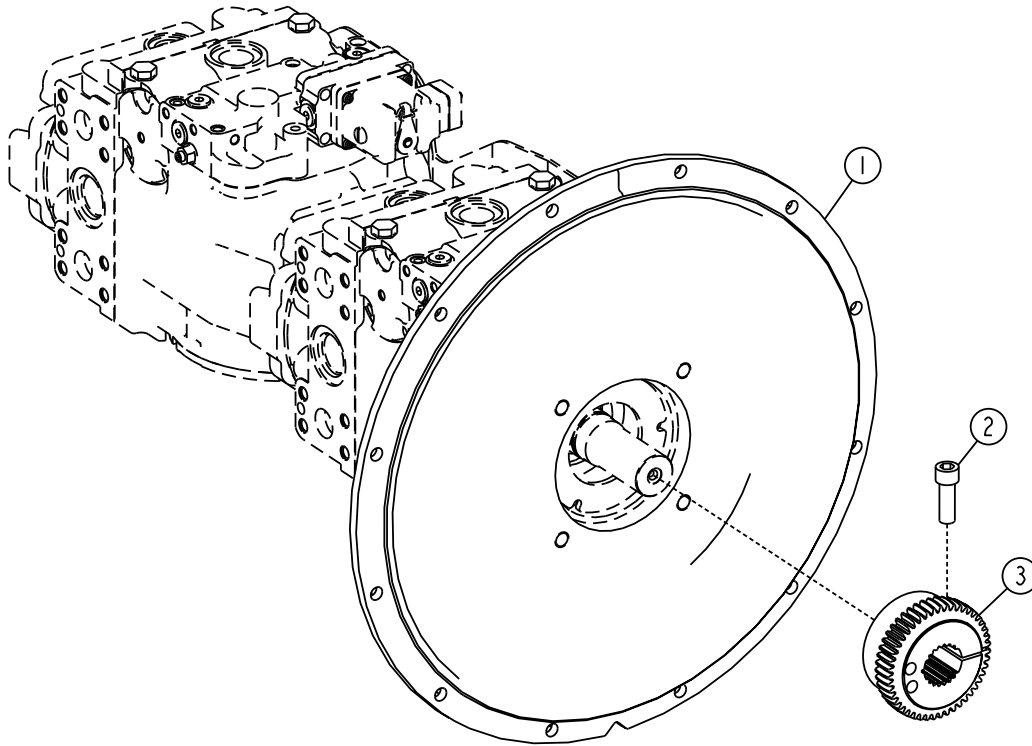

T200377

T200377 —UN—04DEC09

*Dampener Assembly*

- 1— Flywheel Housing Plate      2— Set Screw      3— Dampener Hub

- 33. Remove set screw (2) and dampener hub (3) from pump drive shaft.
- 34. Remove four pump mounting cap screws and flywheel housing plate (1).
- 35. Install flywheel housing plate on pump. Tighten cap screws to specifications.

- 36. Install dampener hub until internal snap ring contacts end of pump shaft.
- 37. Install set screw (2). Tighten to specification.

**Hydrostatic Pump—Specification**

Hydrostatic Pump-to-Flywheel Housing Plate—Torque.....	150 N·m 115 lb·ft
--	----------------------

**Hydrostatic Pump—Specification**

Dampener Hub-to-Hydrostatic Pump Shaft	
Set Screws—Torque.....	86 N·m 63 lb·ft

Continued on next page

CED,TX03399,5046 -19-04DEC09-9/13

- 38. Assemble pumps using four cap screws (1).
- 39. Install hydraulic lines in position as marked during removal.

**IMPORTANT: If dampener plate has been removed, see Dampener Drive Remove and Install. (Group 0752.) for correct assembly to flywheel.**

- 40. Install hydrostatic pumps.

Adjust lifting chains as necessary when installing pumps to align dampener hub with dampener plate.

Clean threads of flywheel housing cover plate cap screws. Apply cure primer and thread lock and sealer (medium strength) to threads of cap screws and install. Tighten cap screws to specifications.

**Hydrostatic Pump—Specification**

Flywheel Housing Cover	
Plate—Torque.....	57 N·m
	42 lb-ft

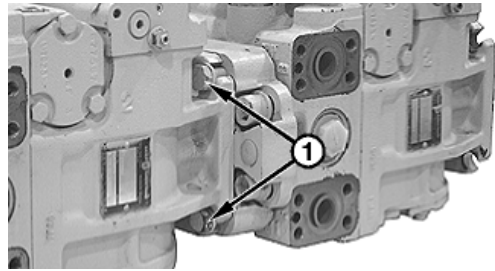

1— Cap Screw (4 used)

- 41. Remove lift eyes from pumps and reinstall fittings.

T11827 1B —UN—08JAN99

Continued on next page

CED, TX03399,5046 -19-04DEC09-10/13

Removal and Installation

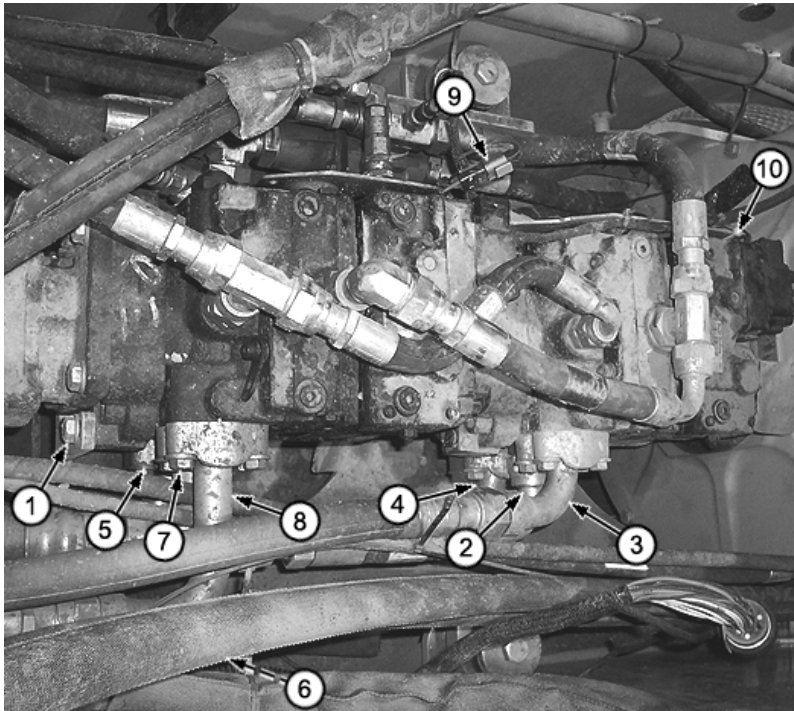

T200360A—UN—26MAY04

- |   |  |   |   |
|---|--|---|---|
| 1—Hydrostatic Pump-to-Rear Mount Bracket Cap Screws (2 used)    | 4—Line (Front Pump Forward Outlet Port-to-R.H. Motor “A” Port) | 7—Tee Fitting   | 10— Front Pressure Control Pilot (PCP) Wiring Connector |
| 2— Line (Front Charge Pump-to-Rear Charge Pump Tee Fitting)     | 5— Line (Rear Pump Forward Outlet Port-to-L.H. Motor “B” Port) | 8—Line (Rear Pump Reverse Outlet Port-to-L.H. Motor “A” Port) |   |
| 3— Line (Front Pump Reverse Outlet Port-to-R.H. Motor “B” Port) | 6— Rear Pump Mount Bracket-to-Frame Cap Screws (4 used)        | 9— Rear Pressure Control Pilot (PCP) Wiring Connector         |   |

42. Install rear pump mount bracket and tighten cap screws (1 and 6).

43. Install lines (2—5, 7 and 8).

44. Connect pressure control pilot (PCP) wiring connectors (9 and 10)

Continued on next page

CEDEX03399,5046 -19-04DEC09-11/13

Removal and Installation

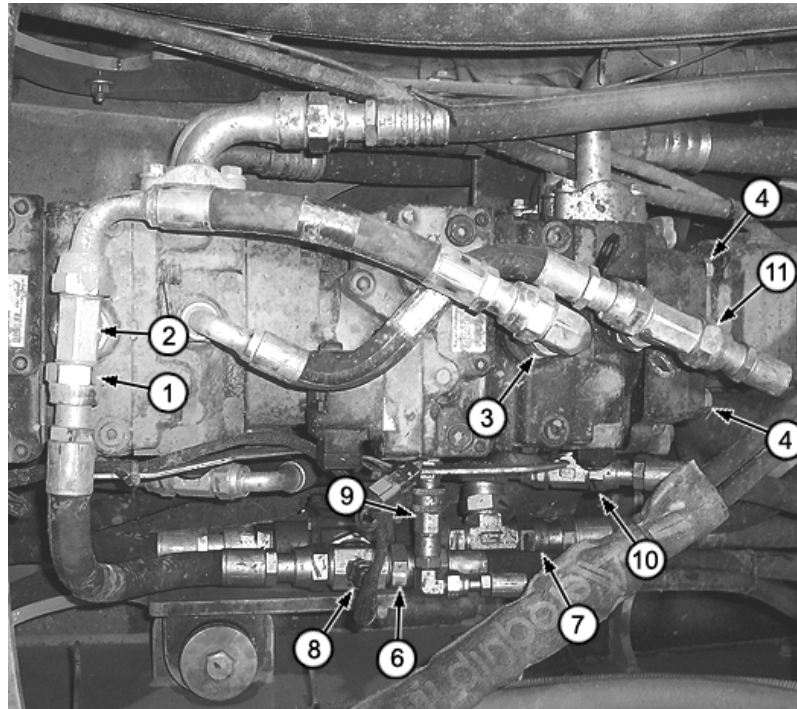

- |  |   |  |                                     |
|--|---|--|-------------------------------------|
| 1—Line (Front Pump Tee Fitting-to-Cooler Bypass Valve) | 4—Hydraulic Pump Mounting Cap Screws (4 used) | 7—Line (Left Motor Tee Fitting-to-Oil Cooler Bypass Valve) | 10—Line (Oil Filter-to-Charge Pump) |
| 2—Tee Fitting (Front Pump)                             | 5—Not Used                                    | 8—Oil Cooler Bypass Valve Wire Terminal                    | 11—Line (Charge Pump-to-Oil Filter) |
| 3—Line Fitting (Rear Pump)                             | 6—Line (Oil Cooler Bypass Valve-to-Reservoir) | 9—Line (Park Brake)  |                                     |

45. Install lines with fittings (1—3), (6, 7, 9 and 10).  
 46. Connect terminal (8).  
 47. Install hydraulic pump. Tighten cap screws (4) to specifications.

**Hydrostatic Pump—Specification**

Hydraulic Pump Mounting	
Cap Screws—Torque.....	140 N·m 103 lb·ft

Continued on next page

CED,TX03399,5046 -19-04DEC09-12/13

T200359A—UN—26MAY04

48. Connect bracket to frame and tighten cap screws (5).
49. Install connectors (1—3).

Route harnesses to original locations and install tie bands.

50. Attach heater valve to bracket and tighten clamps (4).
51. Install heater and connect heater hoses.
52. Install access plate on bottom of hydrostatic reservoir compartment.
53. Fill hydrostatic reservoir. See Transmission and Hydraulic Oil. (Operators Manual.)

**Hydrostatic Pump—Specification**

Hydrostatic Reservoir—Capacity..... 43 L Approximate  
11.3 gal Approximate

54. Fill radiator with coolant. See Fill the Cooling System. (Operators Manual.)

**Hydrostatic Pump—Specification**

Engine Coolant—Capacity..... 11.3 L Approximate  
3 gal Approximate

55. Turn battery disconnect switch to ON.
56. Perform hydrostatic pump start-up procedure. See Hydrostatic Pump and Motor Initial Start-Up Procedure. (Group 9026-25.)

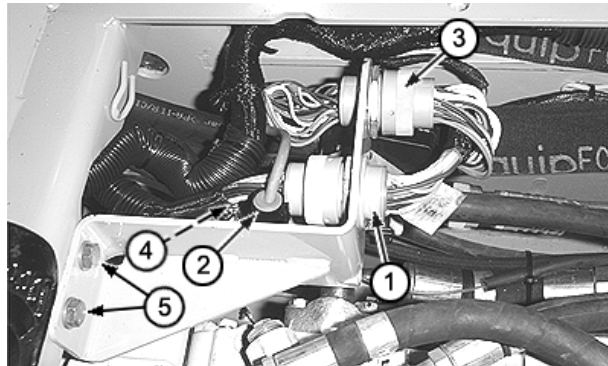

T200959A —UN—16JUN04

- |                                   |   |
|-----------------------------------|---|
| 1— Engine Harness Connector       | 4— Heater Valve Clamp (Cab units only) (2 used) |
| 2— Engine Harness Connector       | 5— Bracket Cap Screw (2 used)                   |
| 3— Transmission Harness Connector |   |

57. Lower seat and secure floor plate.
58. Install tool box (if equipped), knee pads and armrests.
59. Install floor access plate and mat.
60. Calibrate transmission controller. See Transmission Control Unit (TCU) Calibration. (Group 9015-20.)

CED,TX03399,5046 -19-04DEC09-13/13

**Hydrostatic Motor Remove and Install**

1. Lower all equipment to ground.
2. Stop engine. Operate all hydraulic controls to release pressure in hydraulic system.
3. Turn battery disconnect switch to OFF.

*NOTE: Reservoir capacity is approximately 43 L (11.3 gal).*

4. Drain reservoir or apply a vacuum to reservoir.
5. Remove rear access cover or rear mounted optional equipment from rear of machine.
6. Remove left or right floor access plate to disconnect lines.

**CAUTION:** To avoid injury from escaping fluid under pressure, stop engine and relieve the pressure in the system before disconnecting or connecting hydraulic or other lines. Tighten all connections before applying pressure.

7. Tag and mark hose locations to aid in assembly.
8. Disconnect case drain hose (1), diagnostic pressure hoses (4), and park brake hose (7).

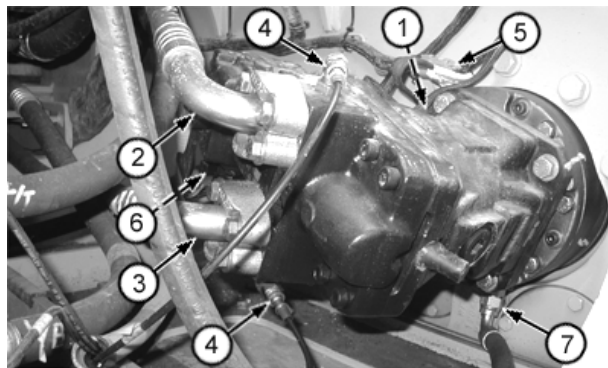

T199187A —UN—13APR04

- |                           |                                   |
|---------------------------|-----------------------------------|
| 1— Case Drain Hose        | 5— Motor Speed Sensor Connector   |
| 2— Forward Direction Hose | 6— Motor Shift Solenoid Connector |
| 3— Reverse Direction Hose | 7— Park Brake Hose                |
| 4— Diagnostic Hose        |                                   |

9. Disconnect forward and reverse hoses (2 and 3).
10. Close all openings using caps and plugs.
11. Disconnect wire connectors from motor shift solenoid (6) and motor speed sensor (5).

Continued on next page

TE14778,0000021 -19-22MAR10-1/2

**CAUTION:** The approximate weight of hydrostatic motor is 38.5 kg (85 lb).

*NOTE: DFT1137 Hydrostatic Motor Removal and Installation Tool will need to be updated. A threaded hole is added to remove right side motor. See DFT1137 Hydrostatic Motor Removal and Installation Tool. (Group 9900.)*

12. Attach DFT1132 Hydrostatic Motor and Hydraulic Pump Removal and Installation Tool to hoist with sling. See DFT1132 Hydrostatic Motor Removal and Installation Tool. (Group 099.)
13. Attach DFT1137 Hydrostatic Motor Removal and Installation Tool to motor. See DFT1137 Hydrostatic Motor Removal and Installation Tool. (Group 9900.)
14. Attach DFT1132 to eyebolt in DFT1137.
15. Remove four cap screws and washers from motor-to-mounting flange.
16. Carefully pry motor away from mounting flange.
17. Remove through hole in rear of machine.
18. Clean threads of mounting studs and nuts.
19. Repair or replace motor.
20. Apply petroleum jelly to new O-ring and install on transmission motor flange.
21. Guide hydrostatic motor through frame opening.
22. Position motor on studs and align splines in coupler and slide motor into position.
23. Apply cure primer and plastic gasket to threads of nuts and tighten to specification.

**Specification**

Hydrostatic Motor	
Mounting Cap	
Screws—Torque.....	130 N·m
	95 lb·ft

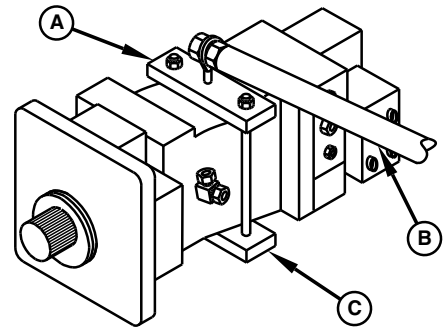

Hydrostatic Motor Removal

- A—DFT1137 Hydrostatic Motor Removal and Installation Tool
- B—DFT1132 Hydrostatic Motor Removal and Installation Tool
- C—DFT1137 Hydrostatic Motor Removal and Installation Tool

24. Remove hydrostatic motor removal and installation tools.
25. Connect hydrostatic lines and wiring connector.
26. Fill reservoir if drained. See Transmission and Hydraulic Oil. (Operators Manual.)
27. Turn battery disconnect switch to ON.
28. Perform Hydrostatic Pump and Motor Initial Start-Up Procedure. (9026-25.)
29. See Transmission Control Unit (TCU) Calibration. (9015-20)
30. Install rear access plate or rear mounted optional equipment.
31. Replace bottom access plates if removed.

TX1074259—UN—05APR10

TE14778,0000021 -19-22MAR10-2/2



## Transmission Control Lever (TCL) Remove and Install

1. Turn battery disconnect switch to the OFF position.  
*NOTE: Mark electrical connectors to aid in assembly.*
2. Disconnect rotary sensors (1 and 3) and neutral start switch (2).
3. Disconnect harness connectors (4 and 5) to transmission speed control switch and horn button.

- |                        |                                  |
|------------------------|----------------------------------|
| 1—Steer Sensor         | 4—Harness to Horn Switch         |
| 2—Neutral Start Switch | 5—Harness to Transmission Switch |
| 3—FNR Sensor           |                                  |

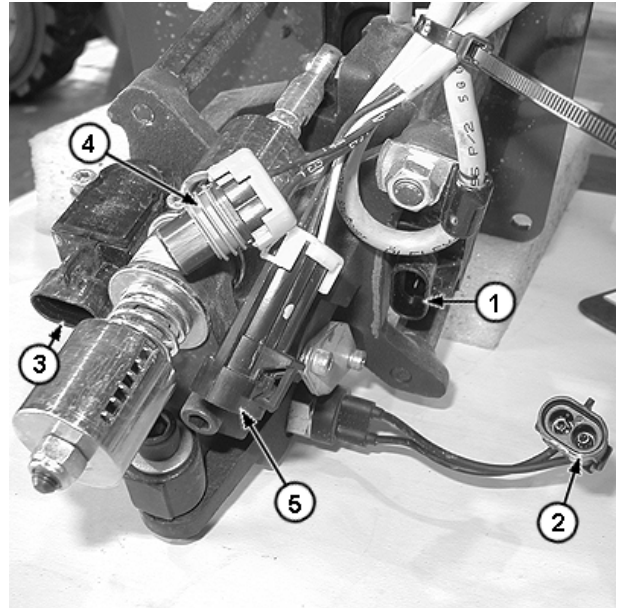

T199271A—UN—16APR04

CED,TX03543,2276 -19-09SEP99-1/2

4. Remove four hex flange screws and transmission control lever (TCL) assembly.
5. Install transmission control lever (TCL) assembly using four hex flange screws.
6. Connect rotary sensors (1 and 3) and neutral start switch (2).
7. Turn battery disconnect switch to the ON position.
8. Adjust transmission control lever (TCL). See Transmission Control Lever (TCL) Adjustment. (Group 9015-20.)
9. Recalibrate transmission controller. See Transmission Control Unit (TCU) Calibration. (Group 9015-20.)

- 1—Hex Flange Screw

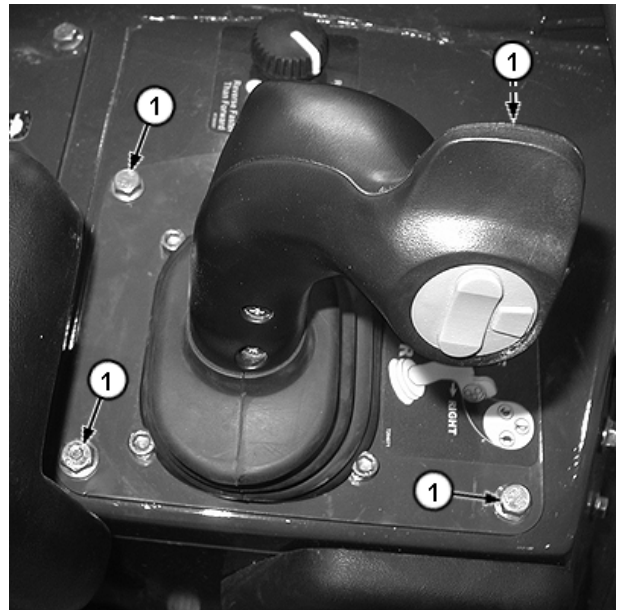

T199276A—UN—16APR04

CED,TX03543,2276 -19-09SEP99-2/2

### Transmission Control Lever (TCL) Disassemble and Assemble (S.N. —130885)

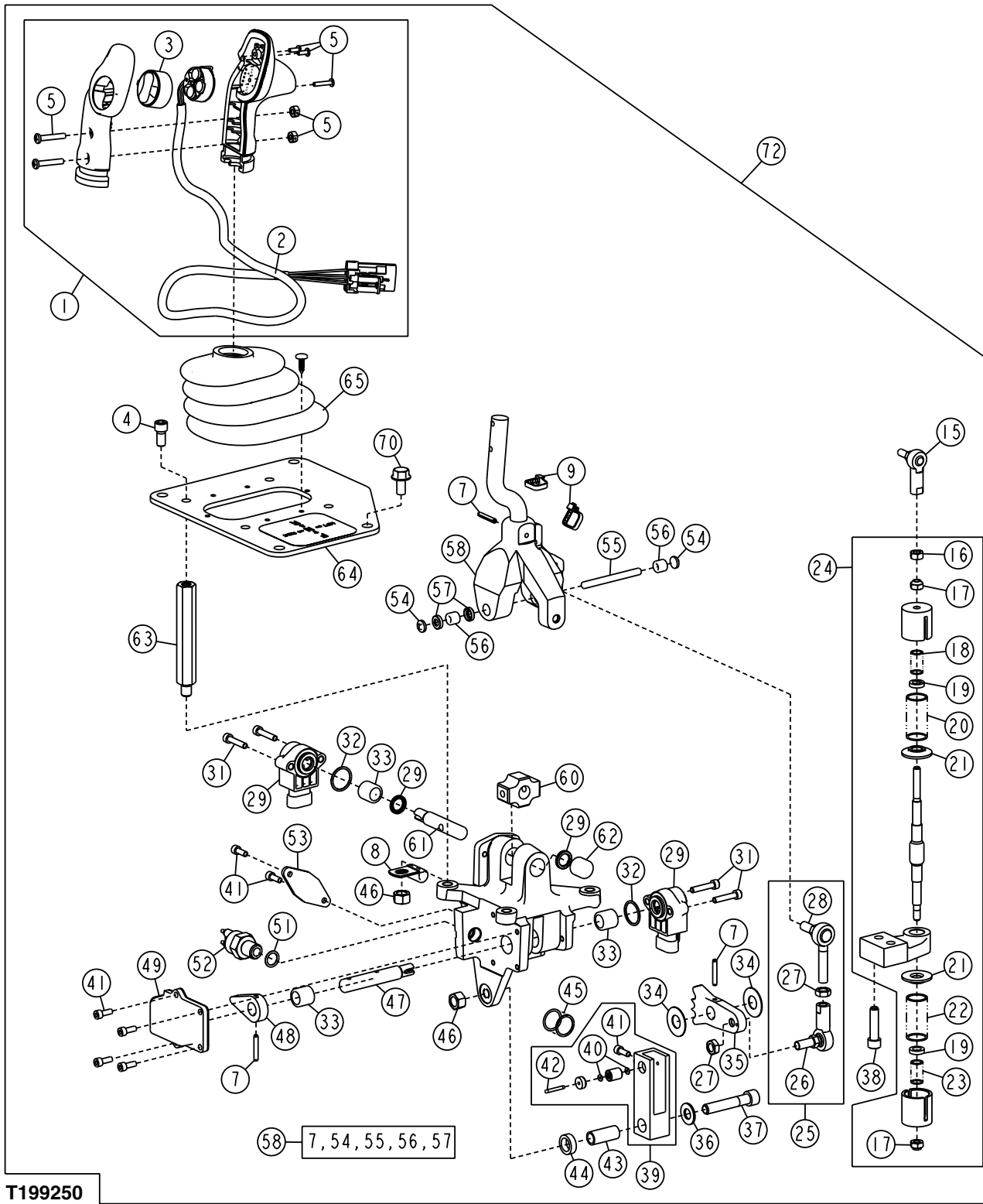

Transmission Control Lever (TCL)

T199250 —UN—15APR04

Continued on next page

CED,OUTX547,108 -19-29SEP99-1/30

## Controls Linkage

1— Transmission Control Lever (TCL)	19— Spacer (2 used)	37— Socket Head Screw	55— Shaft
2— (TCL) Harness, Switch and Cover	20— Spring	38— Cap Screw (2 used)	56— Needle Bearing (2 used)
3— Switch Cover	21— Stepped Washer (2 used)	39— Detent Lever Assembly	57— Lip Seal (2 used)
4— Cap Screw (4 used)	22— Spring	40— O-Ring (2 used)	58— Bracket Assembly
5— Screw kit For Handle	23— Spring	41— Cap Screw (6 used)	59— Lip Seal (2 used)
6— Not Used	24— Spring Pack Assembly	42— Socket Head Cap Screw	60— Bearing Block
7— Spring Pin (3 used)	25— Linkage	43— Spacer	61— Shaft
8— Cable Clamp	26— Ball Joint	44— Spacer	62— Needle Bearing
9— Tie Band	27— Nut (2 used)	45— Spring	63— Mounting Post (4 used) Longer Threaded Post Shown
10— Not Used	28— Ball Joint	46— Nut (2 used)	64— Mounting Plate And FNR Label
11— Not Used	29— Rotary Sensor Kit	47— Detent Shaft	65— Boot Assembly
12— Not Used	30— Not Used	48— Neutral Cam	66— Not Used
13— Not Used	31— Cap Screw (2 used)	49— Cam Cover	67— Not Used
14— Not Used	32— O-Ring	50— SLC Body	68— Not Used
15— Ball Joint	33— Bearing (3 used)	51— O-Ring	69— Not Used
16— Nut	34— Washer (2 used)	52— Neutral Start Switch	70— Screw (4 used)
17— Nut (2 used)	35— Plate	53— Spring Plate	71— Not Used
18— Spring	36— Washer	54— Seal Plug (2 used)	72— Transmission Control Lever (TCL) Assembly

CED.OUTX547,108 -19-29SEP99-2/30

1. Remove transmission control lever (TCL) from side console. See Transmission Control Lever (TCL) Remove and Install. (Group 0315.)



T199273A—UN—16APR04

Continued on next page

CED.OUTX547,108 -19-29SEP99-3/30

## Controls Linkage

- Separate boot from plate using a screwdriver.
- Remove tie bands (1).
- Put identification marks (2) on both sides of wire lead to aid in assembly.
- Remove clamp (3) from wire lead.
- Remove screws (1, 2 and 3) and boot from SLC.
- Split grip halves (1) to remove switch (2). Boot (3) on switch can be replaced, if necessary.

1— Tie Bands  
2— Identification Marks

3— Clamp

1— Screw (2 used)  
2— Screw

3— Screw with nut (2 used)

1— Grip  
2— Switch

3— Boot

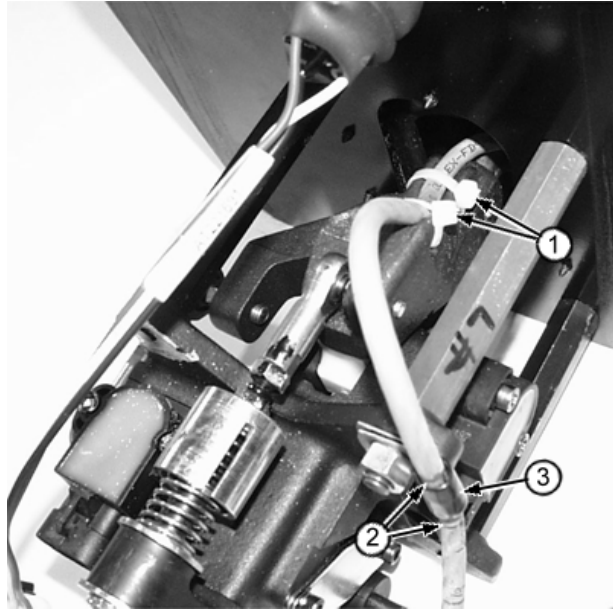

T124638B —UN—17SEP99



T124645B —UN—17SEP99

SLC Assembly With Speed In Grip Shown

Continued on next page

CED,OUTX547,108 -19-29SEP99-4/30

## Controls Linkage



T124646B—UN—17SEP99

Speed In Grip Switch

CED.OUTX547,108 -19-29SEP99-5/30

2. Loosen lock nut (1).
3. Remove steer shaft (2) from rod end (3).
4. Remove two socket head cap screws (4) and remove steer shaft assembly from body.

1— Lock Nut  
2— Steer Shaft

3— Rod End  
4— Socket Head Cap Screw (2 used)

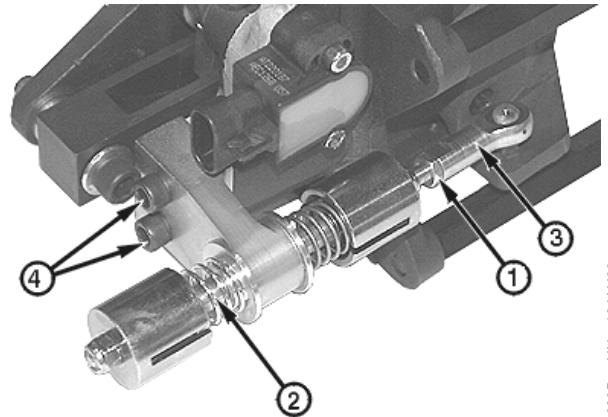

T119639B—UN—19JAN99

Continued on next page

CED.OUTX547,108 -19-29SEP99-6/30

## Controls Linkage

5. Remove rod end lock nut (8).

*NOTE: Use two wrenches to loosen spring end lock nuts (1).*

*NOTE: Springs are color coded to aid in assembly.*

6. Remove one spring end lock nut (1), spring guide (2), spacer (3), spring (4) or (7) and spring seat (5) from one side of steering plate (6).

7. Place steer shaft (9) in soft jaw vise and remove spring end lock nut (1), spring guide (2), spacer (3), spring (4) or (7) and spring seat (5) from other side of steering plate.

- |                                |                    |
|--------------------------------|--------------------|
| 1—Spring End Lock Nut (2 used) | 6—Steering Plate   |
| 2—Spring Guide (2 used)        | 7—Springs (Gold)   |
| 3—Spacer (2 used)              | 8—Rod End Lock Nut |
| 4—Springs (Chrome)             | 9—Steer Shaft      |
| 5—Spring Seat (2 used)         |                    |

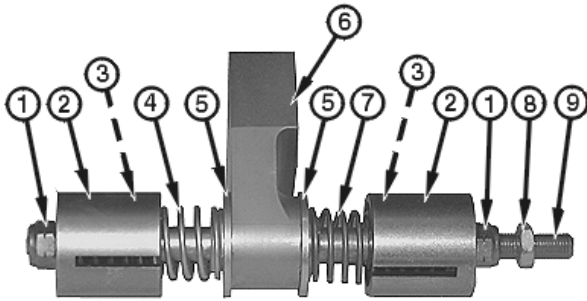

T119641B—UN—19JAN99

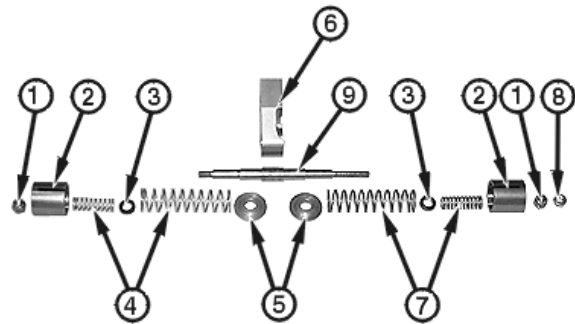

T119642B—UN—19JAN99

CED,OUTX547,108 -19-29SEP99-7/30

8. Remove two socket head cap screws (1), retaining plate (2) and detent spring (3).

9. Remove nut (4), socket head cap screw (8), spacer (5), washer (7) and detent lever (9).

10. Remove tube (6) from detent lever.

- |                                   |                         |
|-----------------------------------|-------------------------|
| 1—Socket Head Cap Screws (2 used) | 6—Tube                  |
| 2—Retaining Plate                 | 7—Washer                |
| 3—Detent Spring                   | 8—Socket Head Cap Screw |
| 4—Nut                             | 9—Detent Lever          |
| 5—Spacer                          |                         |

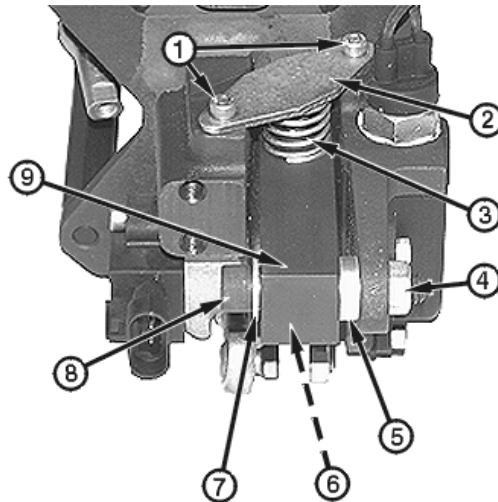

T119643B—UN—19JAN99

Continued on next page

CED,OUTX547,108 -19-29SEP99-8/30

## Controls Linkage

11. Remove socket head cap screws from steer sensor (1) and forward/reverse sensor (2).

Remove sensors and O-rings.

12. Remove cover (3) and neutral start switch (4).

- |                           |                         |
|---------------------------|-------------------------|
| 1— Steer Sensor           | 3— Cover                |
| 2— Forward/Reverse Sensor | 4— Neutral Start Switch |

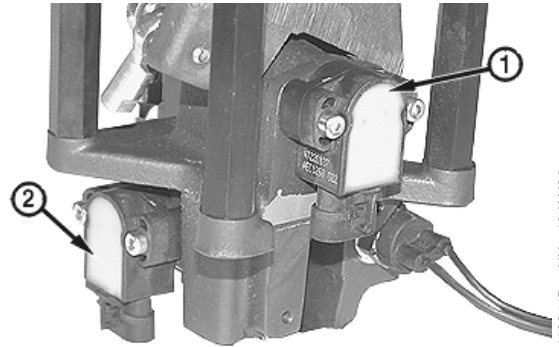

T119644B —UN—19JAN99

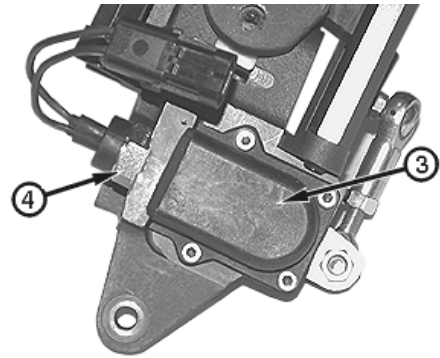

T119645B —UN—19JAN99

CED.OUTX547,108 -19-29SEP99-9/30

13. Disconnect forward/reverse rod end (1) and remove steer rod end (2) from bracket assembly (3).

- |                        |                     |
|------------------------|---------------------|
| 1— Forward/Reverse Rod | 3— Bracket Assembly |
| 2— Steer Rod           |                     |

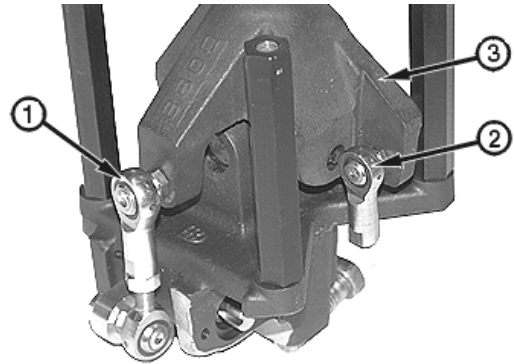

T119646B —UN—19JAN99

Continued on next page

CED.OUTX547,108 -19-29SEP99-10/30

## Controls Linkage

**NOTE:** Care should be taken to avoid damaging bearing block, bearings and seals.

14. Remove two seal plugs and using a 1/4 in. punch with rounded edges, drive pivot pin (1) from bracket assembly. Remove bracket.

1—Pivot Pin

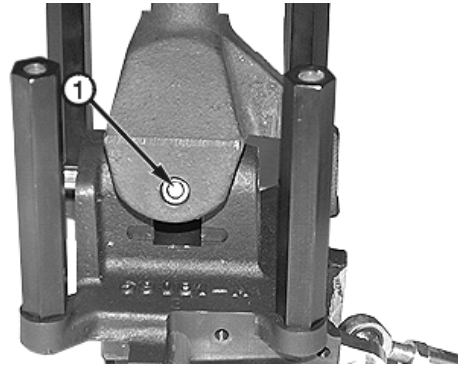

T119646B —UN—19JAN99

CED.OUTX547,108 -19-29SEP99-11/30

15. Remove steer sensor shaft (2) and bearing block (1).

1—Bearing Block

2—Steer Sensor Shaft

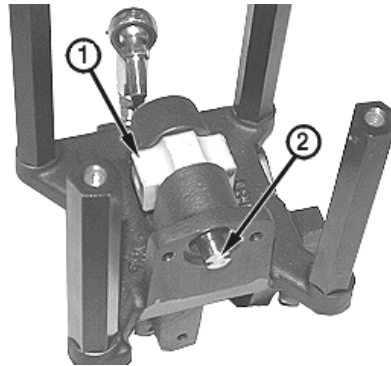

T119650B —UN—19JAN99

CED.OUTX547,108 -19-29SEP99-12/30

**NOTE:** When driving pin out of detent plate, support assembly to prevent damage to bearings and seals.

16. With the detent placed at the furthest reverse position, drive spring pin (1) out until detent plate (2) can be rotated around detent shaft (3).

17. Remove detent shaft (3) by pulling on cam (5). Be sure to catch detent plate (2) with rod end assembly and two spacers (4) when removing detent shaft.

18. Remove rod end assembly from detent plate, if replacement is required.

19. Remove cam (5) from detent shaft (3) by driving out spring pin, if replacement is required.

20. Remove pin (1) from detent plate.

1—Spring Pin  
2—Detent Plate  
3—Detent Shaft

4—Spacers (2 used)  
5—Cam

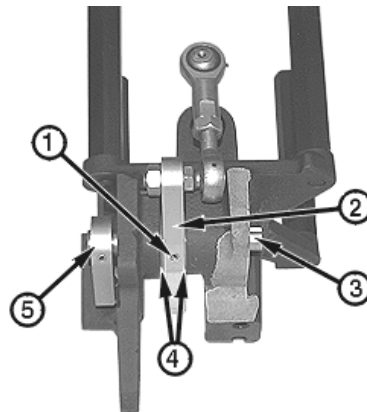

T119651B —UN—18JAN99

Continued on next page

CED.OUTX547,108 -19-29SEP99-13/30

## Controls Linkage

21. Remove yoke pivot pin seals (1) and steer shaft seals (3) using a pick.
22. Remove yoke pivot pin bearings (2) using a punch.
23. Remove steer shaft bearings (4) and detent shaft bearings (5) using JDG1303-1 Bearing Driver and JDG1303-2 or JDG1303-3 Sleeve from JDG1303 Bearing Driver Kit.
24. Clean and inspect parts.

- |                                    |                                  |
|------------------------------------|----------------------------------|
| 1— Yoke Pivot Pin Seal (2 used)    | 4— Steer Shaft Bearing (2 used)  |
| 2— Yoke Pivot Pin Bearing (2 used) | 5— Detent Shaft Bearing (2 used) |
| 3— Steer Shaft Seal (2 used)       |                                  |

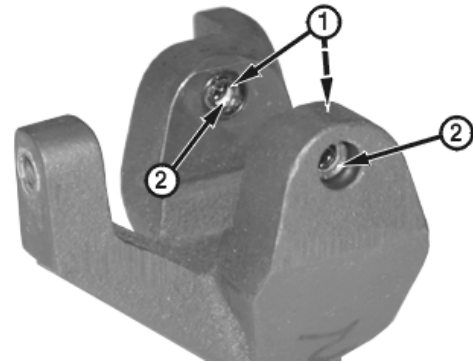

T121377B —UN—11MAY99

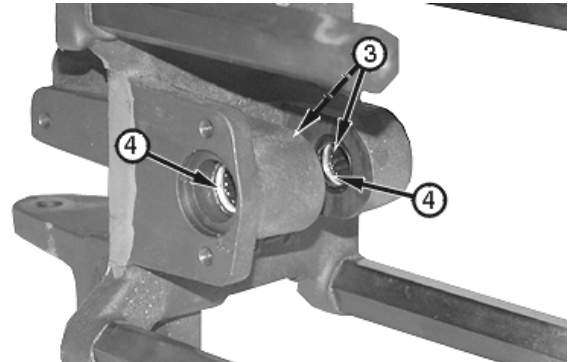

T121378B —UN—11MAY99

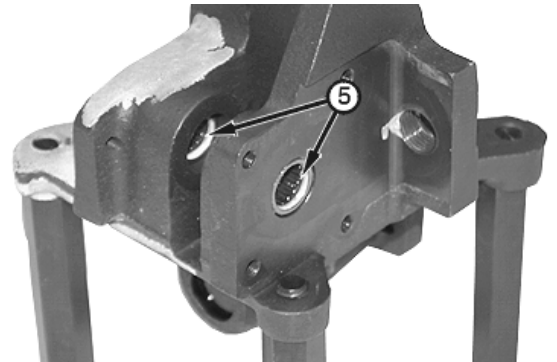

T121379B —UN—11MAY99

Continued on next page

CED,OUTX547,108 -19-29SEP99-14/30

**IMPORTANT: Drive bearing from lettered side of bearing only.**

- 25. Install yoke pivot pin bearing (3) using JDG1303-4 Driver Disk and JDG1303-5 Driver Rod. Drive bearing until driver disk is fully seated on yoke, this will set bearing to proper depth.
- 26. Repeat step 28 for installing other yoke pivot pin bearing.

**IMPORTANT: Lip side of seal must face away from bearing.**

- 27. Apply petroleum jelly to seal and install seal (5) on JDG1303-7 Driver Disk (4) with lip of seal facing toward driver disk.
- 28. Place seal and driver disk square on yoke. Insert JDG1303-5 Driver Rod and drive seal until driver disk is fully seated on yoke.
- 29. Repeat steps 30 and 31 for installing other yoke pivot pin seals.

- |                                    |                            |
|------------------------------------|----------------------------|
| 1— JDG1305-5 Driver Rod            | 4— JDG1303-7 Driver Disk   |
| 2— JDG1303-4 Driver Disk           | 5— Yoke Pivot Pin (2 used) |
| 3— Yoke Pivot Pin Bearing (2 used) |                            |

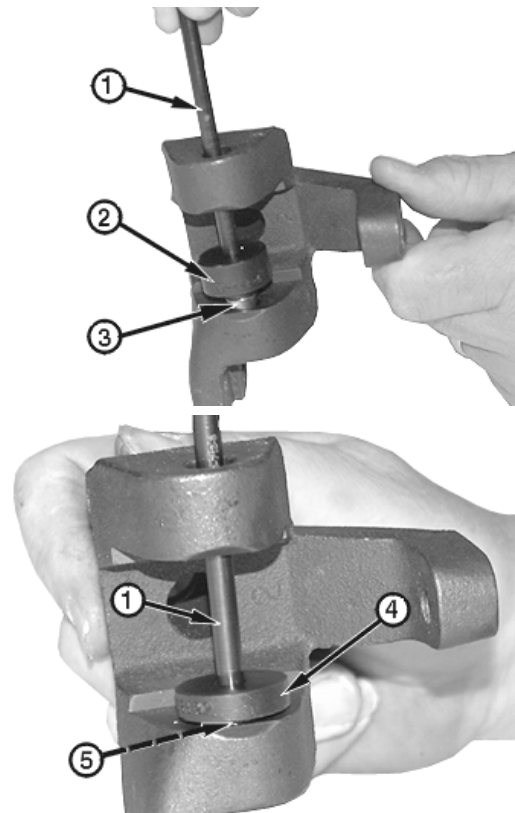

T121380B—UN—11MAY99

T121381B—UN—11MAY99

Continued on next page

CED.OUTX547,108 -19-29SEP99-15/30

**IMPORTANT: Drive bearing from lettered side of bearing only.**

30. Install steer shaft cap bearing (3) using JDG1303-1 Bearing Driver (1) and JDG1303-3 Sleeve (2). Drive bearing until driver is fully seated, this will set bearing to proper depth.
31. Install steer shaft bearing (4) using JDG1303-1 Bearing Driver. Drive bearing until driver is fully seated, this will set bearing to proper depth.

**IMPORTANT: Lip side of seal must face away from bearing.**

32. Apply petroleum jelly to seals install seal (5) on JDG1303-6 Driver Disk with lip of seal facing toward driver disk.
33. Place seal and driver disk square in opening and firmly press with finger pressure to install seal. Press disk driver until fully seated.
34. Repeat step 35 and 36 to install other steer shaft seals.

- |                             |                              |
|-----------------------------|------------------------------|
| 1— JDG1303-1 Bearing Driver | 4— Steer Shaft Bearing       |
| 2— JDG1303-3 Sleeve         | 5— Steer Shaft Seal (2 used) |
| 3— Steer Shaft Cap Bearing  |                              |

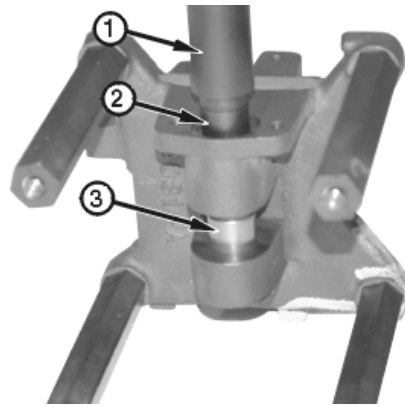

T121382B —UN—11MAY99

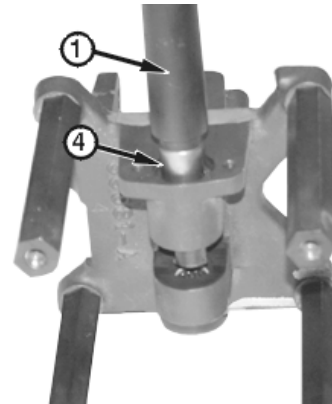

T121383B —UN—11MAY99

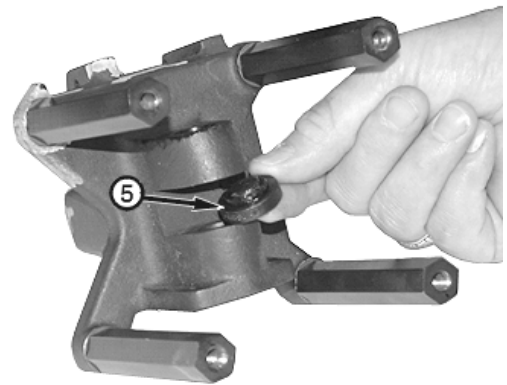

T121384B —UN—11MAY99

Continued on next page

CED,OUTX547,108 -19-29SEP99-16/30



Controls Linkage

*NOTE: Align pin bore in bearing block and sensor shaft.*

40. Install bearing block (1) and steer sensor shaft (2).

- 1— Bearing Block
- 2— Steer Sensor Shaft

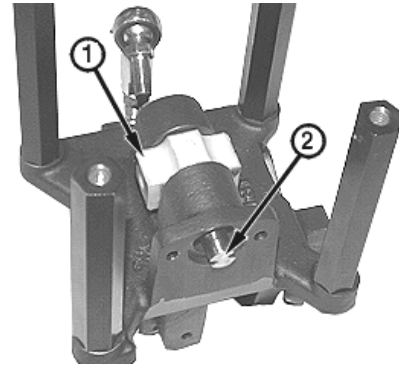

T119650B —UN—19JAN99

CED.OUTX547,108 -19-29SEP99-19/30

*NOTE: Care should be taken to avoid damaging bearing block, bearings and seals.*

- 41. Install lever assembly, and using a 1/4 in. punch with rounded edges, drive pivot pin (1) into bracket assembly. Pin should protrude equally on both ends.
- 42. Install seal plugs.

- 1— Pivot Pin

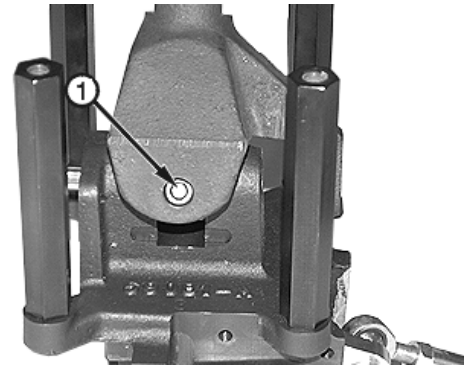

T119649B —UN—19JAN99

CED.OUTX547,108 -19-29SEP99-20/30

- 43. Apply cure primer and thread lock and sealer (medium strength) to threads of rod ends. Connect forward/reverse rod end (1) and install steer rod end (2) on bracket assembly (3). Tighten ball joint nuts to specifications.

**Single Lever Control—Specification**

Forward/Reverse Rod	
Ball Joint Nut—Torque.....	14 N-m
	10 lb-ft
	124 lb-in.
Steer Rod Ball Joint	
Nut—Torque.....	9 N-m
	7 lb-ft
	84 lb-in.

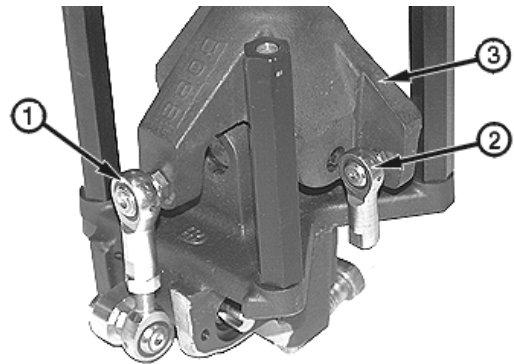

- 1— Forward/Reverse Rod
- 2— Steer Rod
- 3— Bracket Assembly

T119646B —UN—19JAN99

Continued on next page

CED.OUTX547,108 -19-29SEP99-21/30

**NOTE:** Steer sensor and forward/reverse sensors are interchangeable.

44.

Install sensors (1 and 2) and O-rings. Tighten cap screws to specifications.

**Single Lever Control—Specification**

Steer Sensor Mounting	
Cap Screws—Torque.....	5 N·m 4 lb-ft 48 lb-in.

Forward/Reverse Sensor Mounting Cap	
Screws—Torque.....	5 N·m 4 lb-ft 48 lb-in.

45. Install neutral start switch (4) and tighten to specifications.

**Single Lever Control—Specification**

Neutral Start Switch—Torque.....	14 N·m 10 lb-ft 124 lb-in.
----------------------------------	----------------------------------

46. Install cover (3) and tighten cap screws to specifications.

**Single Lever Control—Specification**

Neutral Start Switch Cover Cap	
Screws—Torque.....	5 N·m 4 lb-ft 48 lb-in.

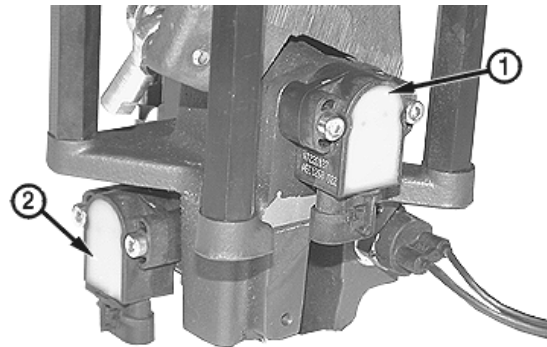

T119644B —UN—19JAN09

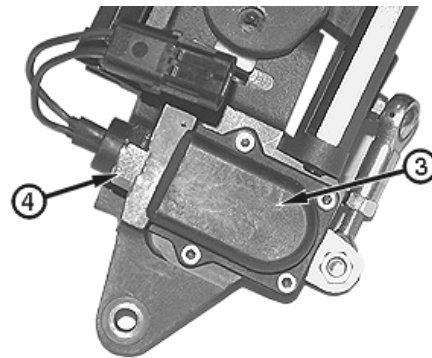

T119645B —UN—19JAN09

- 1— Steer Sensor
- 2— Forward/Reverse Sensor
- 3— Cover
- 4— Neutral Start Switch

Continued on next page

CED,OUTX547,108 -19-29SEP99-22/30

47.

Install tube (6), washer (7), spacer (5), socket head cap screw (8) and nut (4). Tighten cap screw first and then nut, to specifications.

**Single Lever Control—Specification**

Detent Lever Socket	
Head Cap Screw and	
Nut—Torque.....	19 N·m
	14 lb-ft
	168 lb-in.

48. Install detent spring (3), retaining plate (2) and socket head cap screws (1). Tighten cap screws to specifications.

**Single Lever Control—Specification**

Detent Spring	
Retaining Plate Cap	
Screws—Torque.....	5 N·m
	4 lb-ft
	48 lb-in.

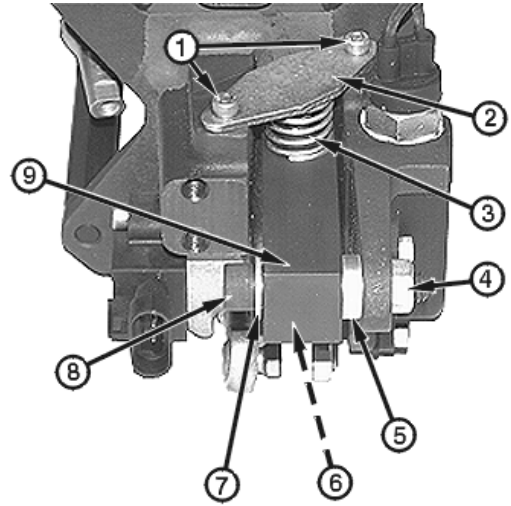

- |                                    |                          |
|------------------------------------|--------------------------|
| 1— Socket Head Cap Screws (2 used) | 6— Tube                  |
| 2— Retaining Plate                 | 7— Washer                |
| 3— Detent Spring                   | 8— Socket Head Cap Screw |
| 4— Nut                             | 9— Detent Lever          |
| 5— Spacer                          |                          |

CED,OUTX547,108 -19-29SEP99-23/30

T119643B —UN—19JAN99

**NOTE:** Steering plate (6) must be installed so that the flat side faces chrome spring (4).

49. Place steering shaft in soft jaw vise. Install steering plate (6), spring seat (5), spring (4) or (7), spacer (3) spring guide (2) and spring end lock nut (1). Repeat steps for opposite end, then tighten spring end lock nuts (1) to specifications.

**Single Lever Control—Specification**

Steer Shaft Spring End	
Lock Nuts—Torque.....	8 N·m
	6 lb-ft
	72 lb-in.

50. Install rod end lock nut (8).

- |                                 |                     |
|---------------------------------|---------------------|
| 1— Spring End Lock Nut (2 used) | 6— Steering Plate   |
| 2— Spring Guide (2 used)        | 7— Springs (Gold)   |
| 3— Spacer (2 used)              | 8— Rod End Lock Nut |
| 4— Springs (Chrome)             | 9— Steer Shaft      |
| 5— Spring Seat (2 used)         |                     |

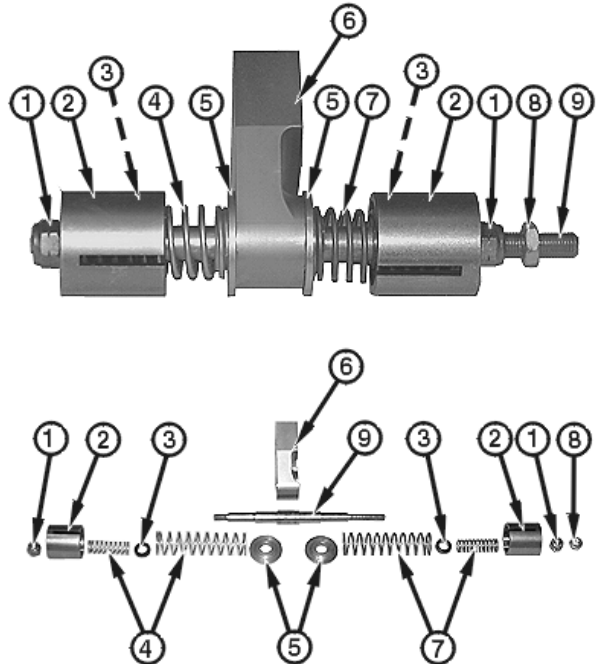

Continued on next page

CED,OUTX547,108 -19-29SEP99-24/30

T119641B —UN—19JAN99

T119642B —UN—19JAN99

Controls Linkage

51.

Install steer shaft assembly and two socket head cap screws (4). Tighten cap screws to specifications.

**Single Lever Control—Specification**

Steer Shaft Assembly	
Mounting Cap	
Screws—Torque.....	34 N·m
	25 lb·ft

52. Screw steer shaft into rod end (3) and tighten lock nut (1).

- |               |                                  |
|---------------|----------------------------------|
| 1—Lock Nut    | 3—Rod End                        |
| 2—Steer Shaft | 4—Socket Head Cap Screw (2 used) |

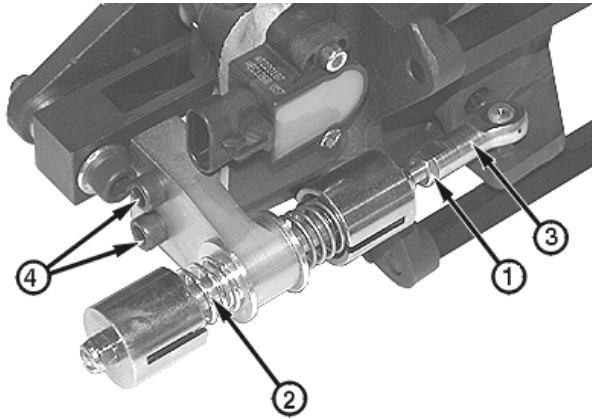

T119639B—UN—19JAN99

CED.OUTX547,108 -19-29SEP99-25/30

53. If removed, install boot (3) and switch (2) in grip (1).



T124646B—UN—17SEP99

Continued on next page

CED.OUTX547,108 -19-29SEP99-26/30

54. Install and tighten screws (1—3).



T124645B —UN—17SEP99

CED,OUTX547,108 -19-29SEP99-27/30

**IMPORTANT: Tie bands MUST be installed and wire lead MUST be positioned in clamp between assembly marks to provide a loop in wiring harness for steering.**

55. Install tie bands (1) on wire harness.

56. Install clamp (3).

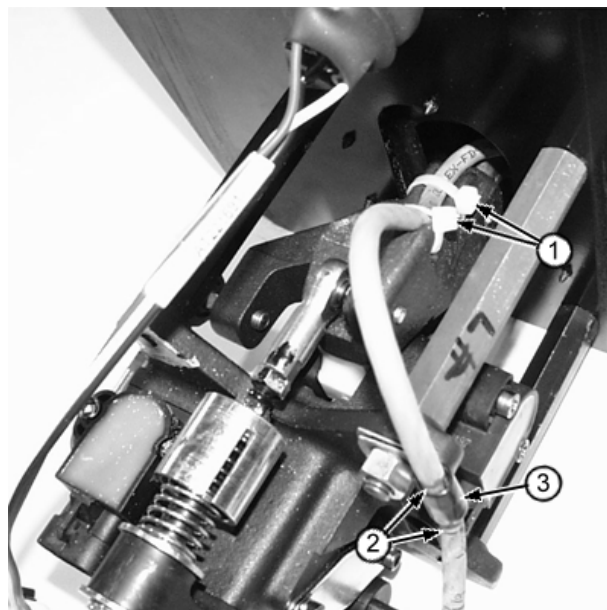

T124638B —UN—17SEP99

Continued on next page

CED,OUTX547,108 -19-29SEP99-28/30

## Controls Linkage

57. Install four socket head cap screws (1) and tighten to specification.

### Specification

Transmission Control Lever (TCL) Top Plate Socket Head Cap Screws—Torque.....	9 N·m 6.6 lb ft
--	--------------------

58. Install boot (2).

**1—Socket Head Cap Screw (4 used)**

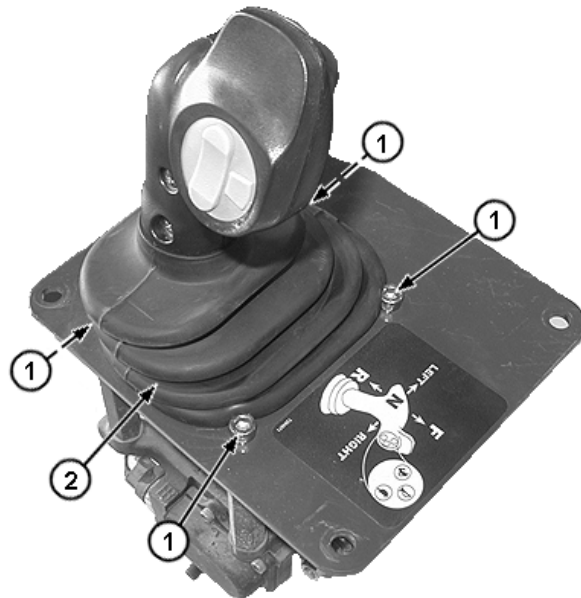

T199277A —UN—16APR04

CED.OUTX547,108 -19-29SEP99-29/30

59. Install transmission control lever (TCL) assembly inside console. See Transmission Control Lever (TCL) Remove and Install. (Group 0315.)

Install four cap screws (1) and tighten to specification.

### Specification

Transmission Control Lever (TCL) Top Plate Cap Screws—Torque.....	37 N·m 27 lb ft
---	--------------------

60. Adjust single lever control. See Transmission Control Lever (TCL) Adjustment. (Group 9015-20.)

61. Recalibrate transmission controller. See Transmission Control Unit (TCU) Calibration. (Group 9015-20.)

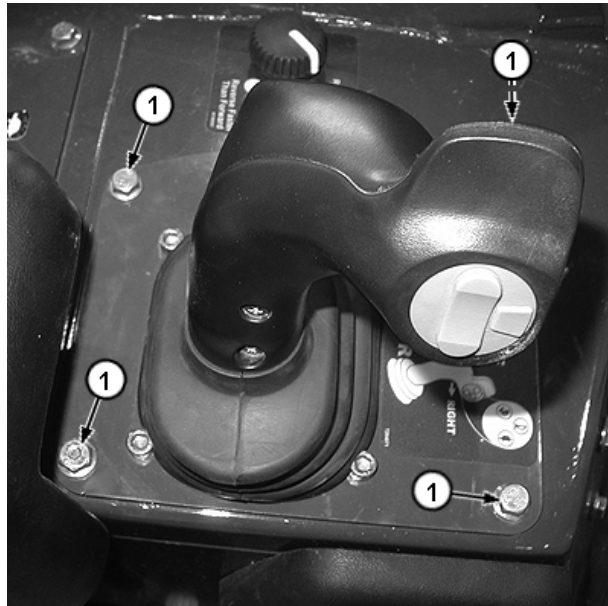

T199276A —UN—16APR04

CED.OUTX547,108 -19-29SEP99-30/30

## Hydrostatic Pumps Disassemble

**CAUTION:** The weight of the hydrostatic pump is approximately 60 kg (133 lb). Use proper lifting equipment and safety precautions. Failure to do so may cause personal injury.

### Hydrostatic Pump—Specification

Hydrostatic  
Pump—Weight..... 60 kg Approximate  
133 lb Approximate

**IMPORTANT: Absolute cleanliness is essential when working on hydraulic components.**

*NOTE: Orientate double boss of pump housing on holding fixture as shown.*

1. Mount the hydrostatic pump on a D01006AA Bench-Mounted Holding Fixture.
2. Remove displacement control valve assembly. See Pump Displacement Control Valve (PDCV) Disassemble and Assemble. (Group 0360.)

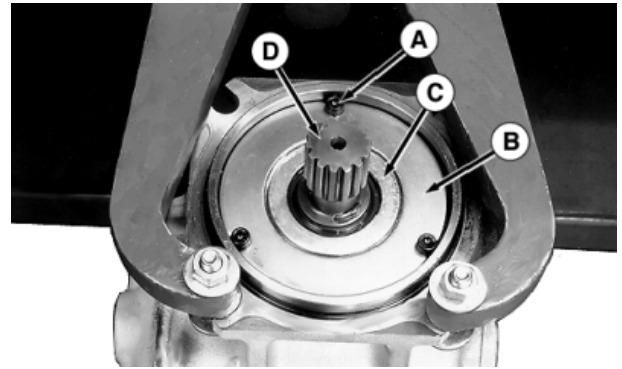

RW25727 —UN—09JUN97

A—Socket Head Cap Screw (3 used)      C—Seal Carrier  
B—Retaining Plate                                      D—Shaft

TE14778,0000040 -19-22APR10-1/19

3. Remove socket head cap screws (A) and retaining plate (B).

*NOTE: The bearings on shaft (D) are slip fit in the housing bore.*

4. Remove seal carrier (C) and shaft (D) with bearings. Lightly tap on opposite end of shaft to aid in removal.

A—Socket Head Cap Screw (3 used)      C—Seal Carrier  
B—Retaining Plate                                      D—Shaft

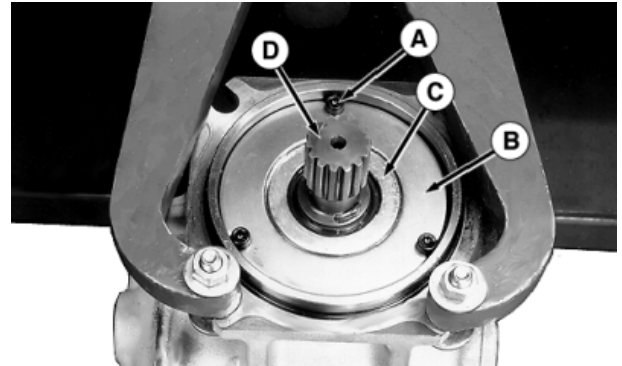

RW25727 —UN—09JUN97

Continued on next page

TE14778,0000040 -19-22APR10-2/19

## Hydrostatic System

5. Inspect bearing assembly (B).
6. Remove retaining ring (A) and remove outer bearing assembly (B) from inner bearing race.
7. Remove inner bearing race from shaft using a press.
8. Install new inner bearing race onto shaft using a press.
9. Install new outer bearing assembly (B) and retaining ring (A) onto shaft.

**IMPORTANT: Cover shaft splines with shim stock to protect lip seal.**

10. Wrap the spline or key end of shaft with thin plastic (shim stock) to prevent damage to the shaft seal lip during installation. Lubricate the inside diameter of the new seal with petroleum jelly. Install new shaft lip seal (C) in seal carrier with spring side of seal toward pump housing.

11. Install O-ring (D) on seal carrier.

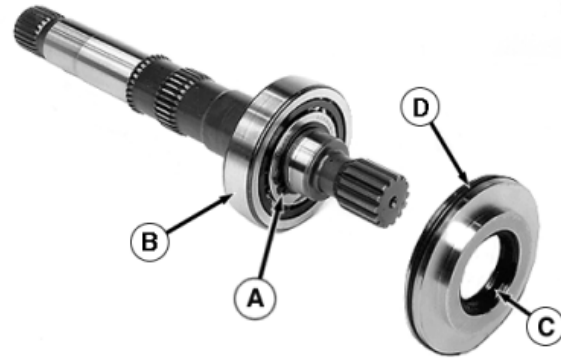

A—Retaining Ring  
B—Bearing Assembly

C—Lip Seal  
D—O-Ring

12. Rotate pump 180°.

RW25728 —UN—11JUN97

TE14778,0000040 -19-22APR10-3/19

13. Remove the two small socket head cap screws (3 and 4) and socket head cap screws with washers (2).

*NOTE: Leveler spring shims may dislodge during end cap removal.*

14. Remove adapter plate and O-ring from end cap. Remove end cap and gasket from pump housing.

1—Adapter Plate  
2—Socket Head Cap Screw with Washer (4 used)

3—Socket Head Cap Screw with Lift Bracket  
4—Socket Head Cap Screw

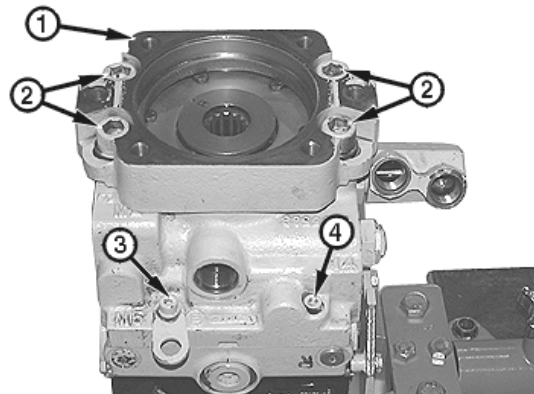

T119614B —UN—15JAN99

Continued on next page

TE14778,0000040 -19-22APR10-4/19

**IMPORTANT: Do not damage the end cap surface when removing or installing bearing (A).**

15. Inspect journal bearing (A).
16. Carefully remove the bearing using D01061AA Blind-Hole Puller (B).
17. Lightly lubricate the new journal bearing and install into end cap using a press.

**Hydrostatic Pump—Specification**

End Cap Journal  
Bearing—Depth..... Flush-to-0.50 mm  
Flush-to-0.020 in.

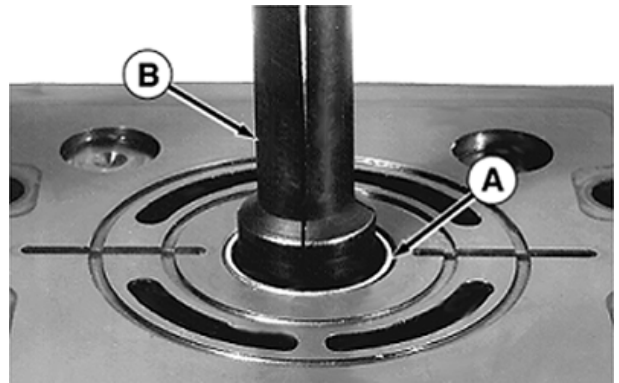

T118279 —UN—17NOV98

A—Journal Bearing

B—Blind Hole Puller

TE14778,0000040 -19-22APR10-5/19

**IMPORTANT: New journal bearing MUST be sized using a JDG1072 Journal Bearing Sizing Tool. DO NOT use the pump shaft. This will cause inadequate lubrication and shortened bearing life.**

18. Size the journal bearing using a JDG1072 Journal Bearing Sizing Tool (C).

C—Journal Bearing Sizing Tool

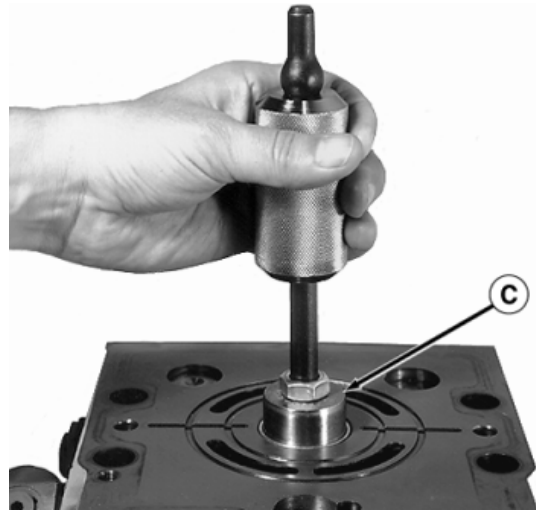

RW25782 —UN—21JUN97

Continued on next page

TE14778,0000040 -19-22APR10-6/19

## Hydrostatic System

**NOTE:** Shims for springs (1) may stay with the end cap during end cap removal.

19. Remove and inspect springs (1 and 4) and shims.

### Swashplate—Specification

Swashplate Leveling	
Outer Springs—Free	
Length.....	88.2 mm Approximate
	3.5 in. Approximate
Test Length.....	83.3 mm at 160 N
	3.3 in. at 36 lb force
Swashplate Leveling	
Inner Springs—Free	
Length.....	81 mm Approximate
	3.2 in. Approximate
Test Length.....	76.2 mm at 78 N
	3.0 in. at 17.5 lb force
Swashplate Hold-Down	
Spring—Free Length.....	
	21.6 mm Approximate
	0.85 in. Approximate
Test Length.....	19.8 mm at 613 N
	0.78 in. at 138 lb force

**IMPORTANT:** Note the direction of arrows stamped on valve plate and mark housing accordingly.

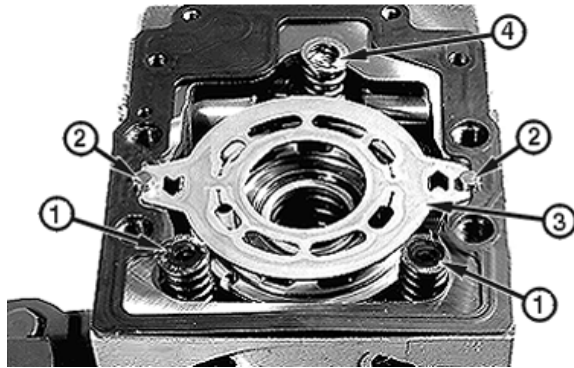

1— Spring (2 used)                      3— Valve Plate  
2— Alignment Pin (2 used)          4— Hold Down Spring

20. Remove valve plate (3).

21. Remove alignment pins (2).

T156798B —UN—27JUN02

TE14778,0000040 -19-22APR10-7/19

22. Put alignment marks (2) on the side cover and pump housing.

23. Remove and discard the six cap screws (1).

1— Cap Screw (6 used)                  2— Alignment Marks

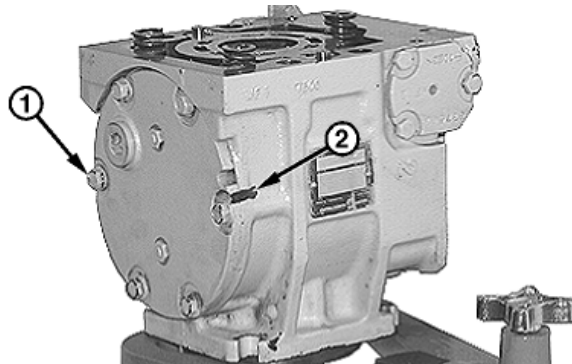

T118259B —UN—08JAN09

Continued on next page

TE14778,0000040 -19-22APR10-8/19

Hydrostatic System

24. Remove leveler assembly (A) by removing two lock nuts on outside of cover.

25. Discard O-ring (B).

A—Leveler Assembly

B—O-Ring

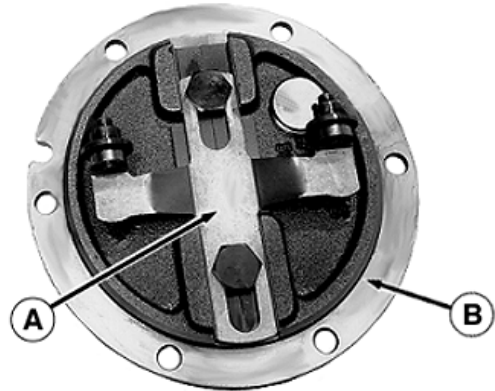

T118277 —UN—22APR99

TE14778,0000040 -19-22APR10-9/19

26. Inspect parts (A—D). Replace as required.

27. Assemble side cover using new lock nuts (E). Tighten nuts to specifications.

**Hydrostatic Pump—Specification**

Swashplate Leveler-  
to-Side Cover Lock

Nuts—Torque.....23 N·m  
17 lb-ft  
204 lb-in.

28. Install O-ring on side cover (A).

A—Side Cover

B—Leveler

C—Insert (2 used)

D—Cap Screw (2 used)

E— Lock Nut (2 used)

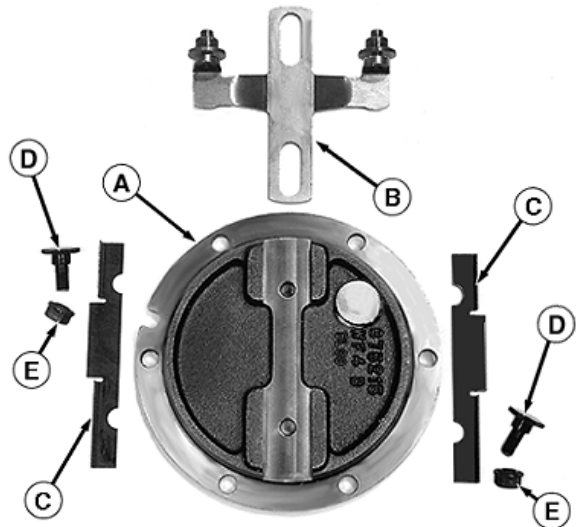

T118278 —UN—22APR99

Continued on next page

TE14778,0000040 -19-22APR10-10/19

**IMPORTANT: Wear patterns develop between servo pistons and servo cylinders. Servo cylinders must be installed in original positions.**

29. Tag or identify servo cylinders (A) for assembly into the bore from which the cylinders were removed.
30. Remove capscrews and remove cylinders (A) using a slide hammer and 8 mm screw in threaded hole (B).

**IMPORTANT: Wear patterns develop between cylinder block bores and pistons. Pistons must be installed in original cylinder block bores.**

31. Tag or identify pistons and cylinder block bores to aid in proper assembly.
32. Remove cylinder block assembly (C).

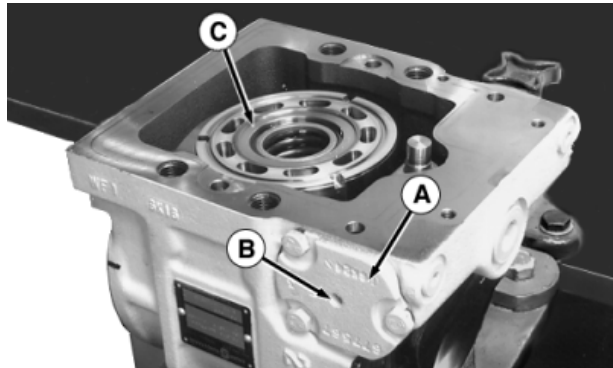

A—Servo Cylinder (2 used)  
B—Threaded Hole

C—Cylinder Block Assembly

RW25735 —UN—20JUN97

TE14778,0000040 -19-22APR10-11/19

33. Compress the cylinder block spring using a press and remove the spiral retaining ring.
34. Remove retainer.
35. Remove spring and spring seats.
36. Clean cylinder block and components.
37. Assemble cylinder block.

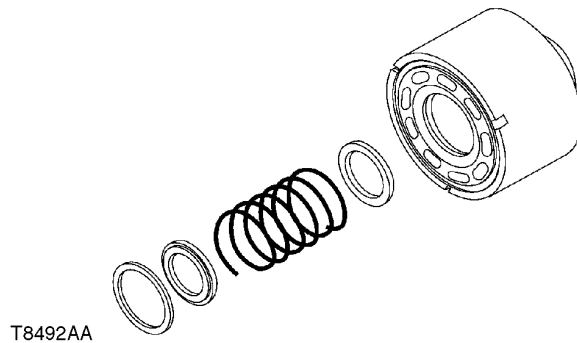

T8492AA

T8492AA —UN—14JUN95

TE14778,0000040 -19-22APR10-12/19

38. Remove bearing cage link pin (A) and locator link (B).

A—Cage Link Pin

B—Locator Link

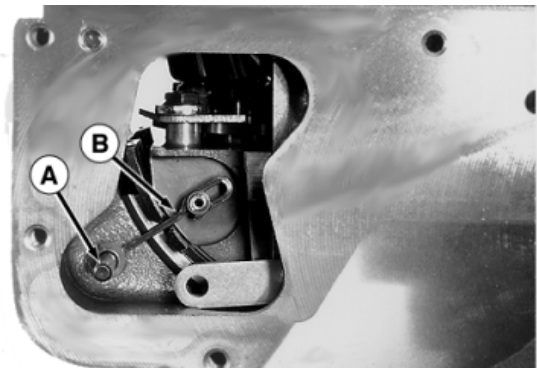

RW25736 —UN—09JUN97

Continued on next page

TE14778,0000040 -19-22APR10-13/19

## Hydrostatic System

39. Remove the swash plate and piston assembly (A) through the housing side cover opening.

**IMPORTANT: Wear patterns develop between servo pistons and servo cylinders. Servo piston must be installed with original orientation.**

40. Tag or identify servo piston orientation to aid in proper assembly.  
41. Remove the servo piston (C) and slider block (B).

A—Swashplate and Piston Assembly  
B—Slider Block  
C—Servo Piston

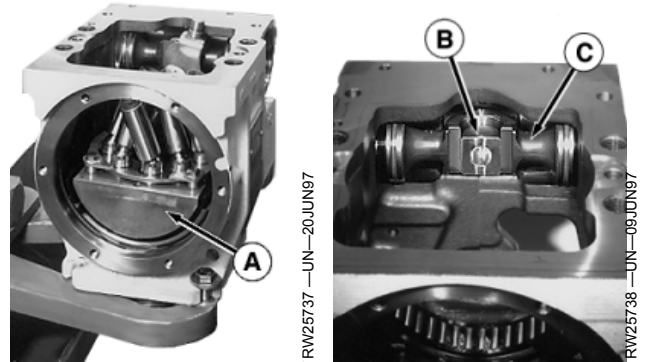

TE14778,0000040 -19-22APR10-14/19

*NOTE: Do not stretch seal rings (B) any more than necessary when installing.*

42. Replace expander O-ring (A) on each end of servo piston.  
43. Install seal ring (B) over O-ring on each end of piston.

A—O-Ring  
B—Seal Ring



TE14778,0000040 -19-22APR10-15/19

**IMPORTANT: Bearing cage wears patterns in bearing race and swash plate. Components must be installed in proper position with original orientation.**

44. Tag or identify swash plate bearing cage positions to aid in proper assembly.  
45. Remove and inspect swash plate bearing cage (A). Replace as required.  
46. Tag or identify bearing race positions to aid in proper assembly.  
47. Remove and inspect the two bearing races (B). Replace as required.

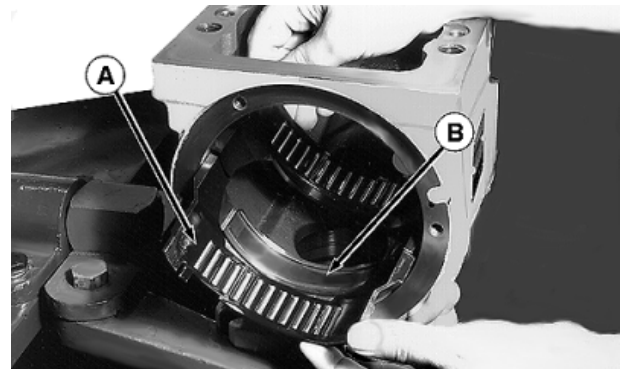

A—Bearing Cage (2 used)  
B—Bearing Race (2 used)

Continued on next page

TE14778,0000040 -19-22APR10-16/19

**IMPORTANT: Parts have critical, high tolerance surfaces which require careful handling to prevent damage.**

48. Disassemble and inspect parts (A—E) discarding cap screws (F).

- A—Swashplate
- B—Piston Assembly (9 used)
- C—Slipper Guide
- D—Slipper Guide Bearing (2 used)
- E—Spacer (4 used)
- F—Cap Screw (4 used)

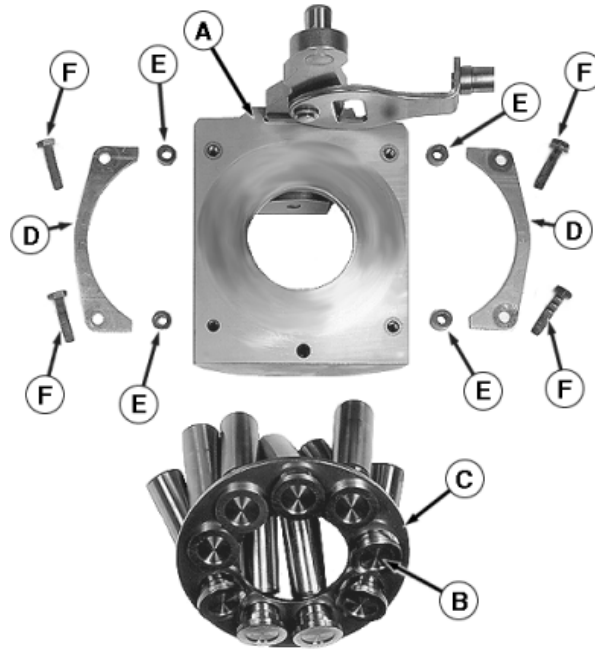

T121170—UN—17APR99

TE14778,0000040 -19-22APR10-17/19

**IMPORTANT: Servo arm alignment is critical. Do not remove servo arm (A) from swash plate unless replacing.**

49. Remove feedback link (C) by removing socket head cap screw (D).

50. Inspect swash plate guide (B).

51. Remove cap screw (E) only if replacement of servo arm is needed.

*NOTE: Servo arm is a press fit.*

52. Install new servo arm carefully aligning the slot and threaded holes in swash plate. Arm must be pressed completely into swash plate slot.

53. Install servo arm cap screw (E) and tighten to specifications.

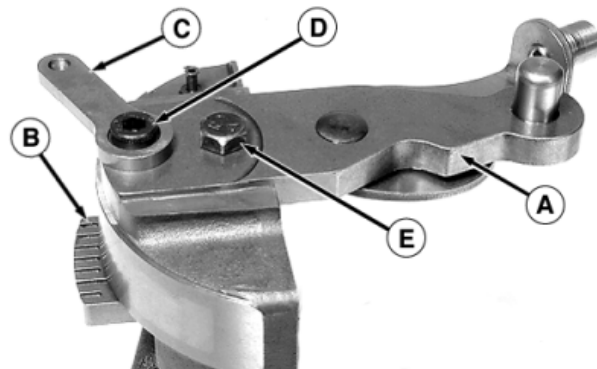

RW25742—UN—11JUN97

- A—Servo Arm
- B—Swashplate Guide
- C—Feedback Link
- D—Socket Head Cap Screw
- E—Cap Screw

**Hydrostatic Pump—Specification**

Swashplate Servo Arm	
Cap Screw—Torque.....	32 N·m 24 lb·ft

**Hydrostatic Pump—Specification**

Swashplate	
Feedback Link Cap	
Screw—Torque.....	32 N·m 24 lb·ft

54. Install feedback link (C) and swash plate guide (B). Tighten socket head cap screw (D) to specifications.

Continued on next page

TE14778,0000040 -19-22APR10-18/19

**IMPORTANT: Threaded holes in swash plate and pump housing side cover opening must be cleaned of old locking compound prior to reassembly.**

55. Clean the threaded holes in the swash plate (A) and pump housing side cover opening (B) using the correct tap.

**IMPORTANT: Pump housing must be clear of any contamination before assembling pump.**

56. Clean inside of pump housing eliminating any excess thread locking compound or other contamination.

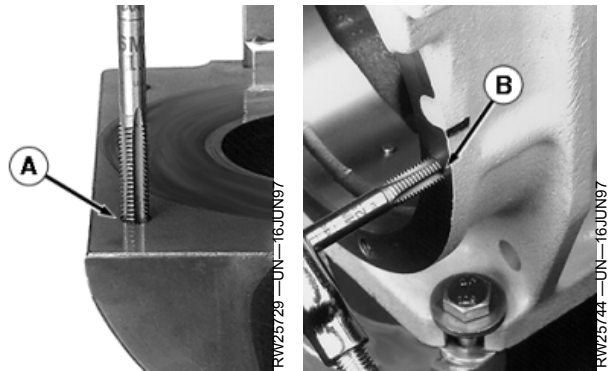

A—M6 Threaded Holes in Swashplate

B—M8 Threaded Holes in Housing

TE14778,0000040 -19-22APR10-19/19

### Hydrostatic Charge Pump Disassemble and Assemble

**IMPORTANT: Absolute cleanliness is essential when working on hydrostatic components.**

1. Remove socket head cap screws (1), adapter (2) and O-ring.

1— Socket Head Cap Screw (4 used)    2— Adaptor Plate used)

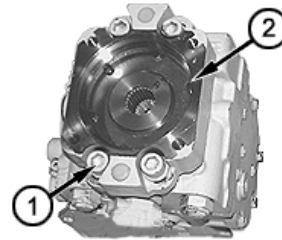

T199994A —UN—17MAY04

CED,OUO1008,146 -19-14MAY04-1/10

2. Remove cap screws (3) and retaining plate (4).

3— Cap Screw (6 used)    4— Retaining Plate



T199995A —UN—17MAY04

Continued on next page

CED,OUO1008,146 -19-14MAY04-2/10

**IMPORTANT: Wear patterns develop between pump gerotor assembly (5) and eccentric ring (6). Components must be installed in proper position with original orientation.**

3. Tag or identify visible side of pump gerotor assembly (5) and eccentric ring (6) to aid in proper assembly.
4. Remove and inspect parts (1—8) and replace as required.
5. Remove bushing from charge pump cover (1).
6. Clean all parts and lightly apply clean hydraulic oil.

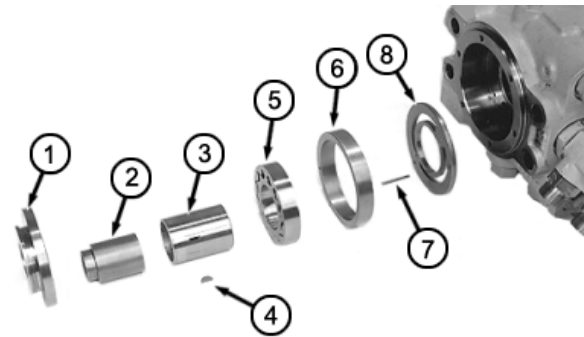

- |                             |  |
|-----------------------------|--|
| 1— Charge Pump Cover        | 5— <sup>1</sup> Charge Pump Gerotor Assembly |
| 2— Auxiliary Drive Coupling | 6— <sup>2</sup> Eccentric Ring               |
| 3— Charge Pump Shaft        | 7— Alignment Pin                             |
| 4— Key                      | 8— Port Plate                                |

<sup>1</sup>Serviced as an assembly  
<sup>2</sup>Serviced as an assembly

T199966A—UN—17MAY04

CED,OUO1008,146 -19-14MAY04-3/10

**IMPORTANT: Charge pump rotation is determined by the orientation of eccentric ring in the gerotor assembly, and the location of the alignment pin (1). Incorrect assembly will not provide charge oil to the pump and will result in damage to the pump.**

*NOTE: One of the large socket head cap screws and four washers must be installed in the end cap, as illustrated, before assembling the charge pump.*

7. Install charge pump alignment pin (1) in the right rotation hole as illustrated.
8. Install port plate (2).

- |                  |               |
|------------------|---------------|
| 1— Alignment Pin | 2— Port Plate |
|------------------|---------------|

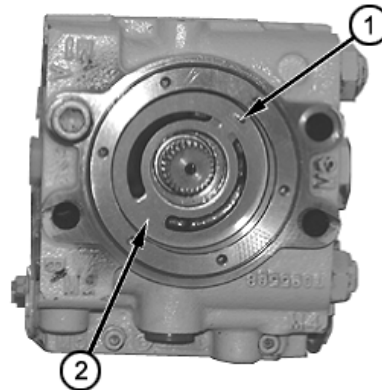

T19997A—UN—17MAY04

Continued on next page

CED,OUO1008,146 -19-14MAY04-4/10

**IMPORTANT: Wear patterns develop between pump gerotor gears (3) and eccentric ring (1). Components must be installed in proper position with original orientation.**

9. Install the eccentric ring (1) making sure alignment pin (2) is correctly installed.
10. Install the gerotor gears (3).

1— Eccentric Ring  
2— Alignment Pin

3— Gerotor Gears

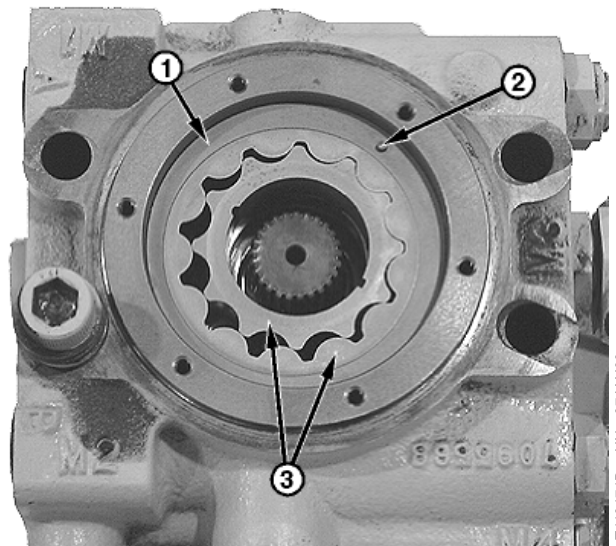

CED,OUO1008,146 -19-14MAY04-5/10

11. Install charge pump shaft (1) with key (2) aligning with slot in gerotor gear.

1— Pump Shaft

2— Key

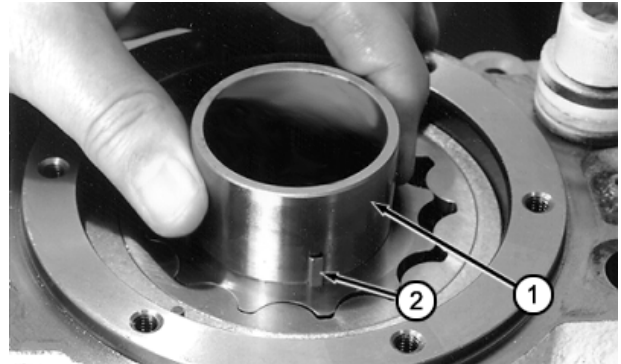

CED,OUO1008,146 -19-14MAY04-6/10

12. Install auxiliary drive coupling (1).

1— Auxiliary Drive Coupling



Continued on next page

CED,OUO1008,146 -19-14MAY04-7/10

## Hydrostatic System

13. Install bushing in charge pump cover.
14. Install charge pump cover (2) making sure hole (1) in cover aligns correctly with alignment pin (3).

- 1—Hole in Cover
- 2—Charge Pump Cover
- 3—Alignment Pin

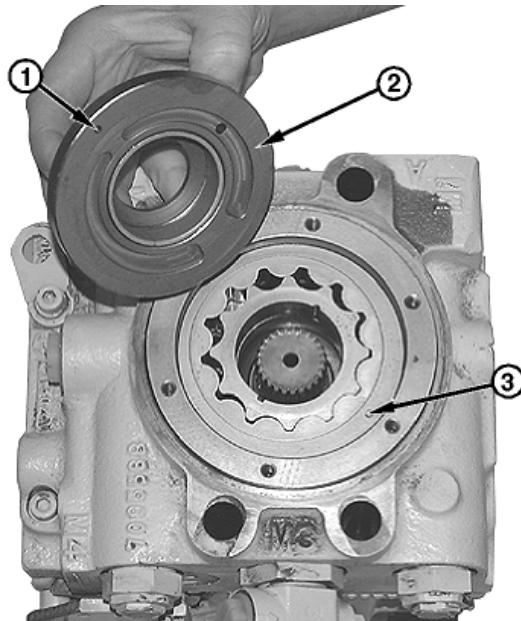

T119172B—UN—07JAN99

CED,OUO1008,146 -19-14MAY04-8/10

15. Install retaining plate (1) and cap screws (2). Tighten to specifications.

### Hydrostatic Pump—Specification

Charge Pump	
Retaining Plate Cap	
Screws—Torque.....	14 N·m
	120 lb-in.

16. Lubricate O-ring (4) with petroleum jelly and install.
17. Remove socket head cap screw and washers (3).

- 1—Retaining Plate
- 2—Cap Screw (6 used)
- 3—Socket Head Cap Screw and Washers
- 4—O-Ring

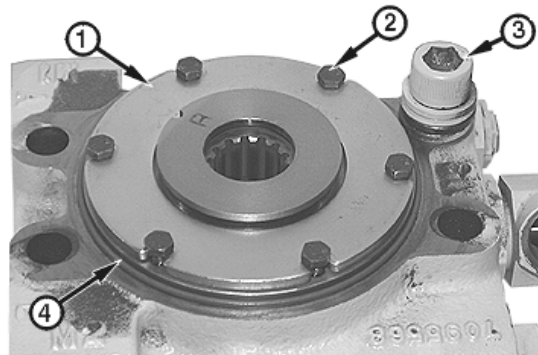

T119594B—UN—22JAN99

Continued on next page

CED,OUO1008,146 -19-14MAY04-9/10

- 18. Install flange adapter (B).
- 19. Install socket head cap screws and washers (1).  
Tighten to specifications.

**Hydrostatic Pump—Specification**

Flange Adapter/End	
Cap-to-Hydrostatic	
Pump—Torque.....	298 N·m 220 lb-ft

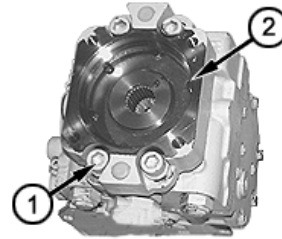

- 20. Install pumps and calibrate transmission control unit (TCU). See Transmission Control Unit (TCU) Calibration. (Group 9015.)

- 1— Socket Head Cap Screw and Washer (4 used)
- 2— Flange Adapter

T199994A —UN—17MAY04

CED,OUO1008,146 -19-14MAY04-10/10

**Pump Displacement Control Valve (PDCV) Disassemble and Assemble**

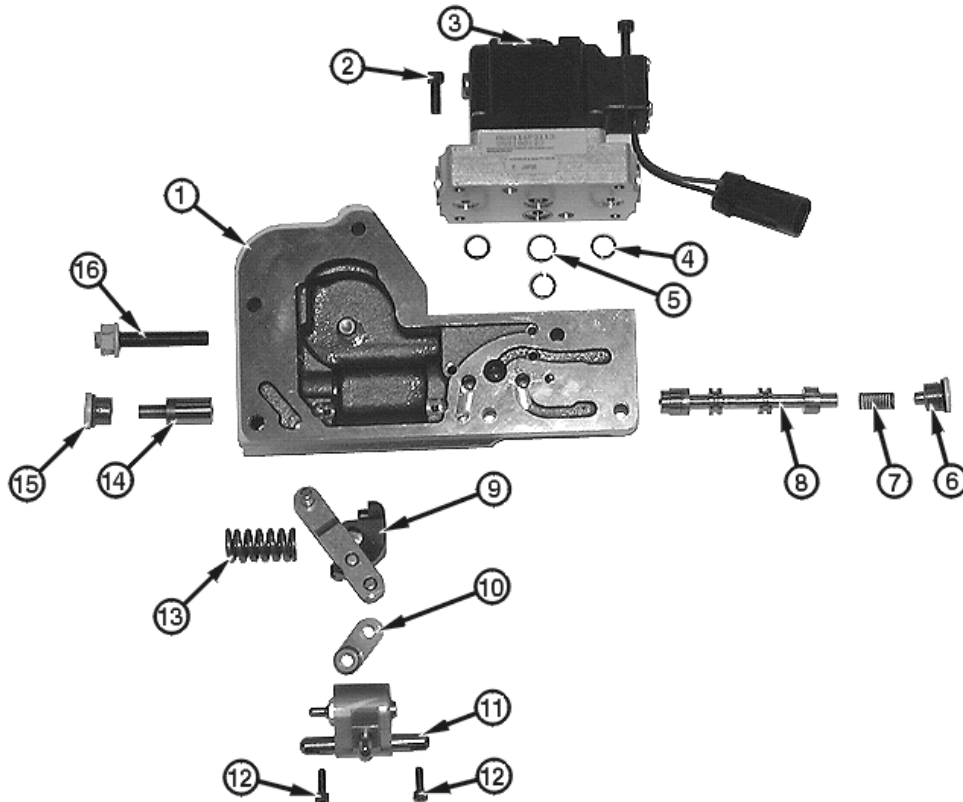

- |                                 |                    |                               |                      |
|---------------------------------|--------------------|-------------------------------|----------------------|
| 1— Control Valve Housing        | 5— O-Ring (1 used) | 9— Feedback Link              | 13— Spring           |
| 2— Cap Screw (4 used)           | 6— Cap             | 10— Link Arm                  | 14— Valve Spool      |
| 3— Pressure Control Pilot (PCP) | 7— Spring          | 11— Override Linkage Assembly | 15— Cap              |
| 4— O-Ring (3 used)              | 8— Valve Spool     | 12— Cap Screw (2 used)        | 16— Adjustment Screw |

**IMPORTANT:** Hydrostatic pump displacement control valve (PDCV) is serviced as an assembly. Replace if damaged. Disassemble for cleaning purposes only.

**Absolute cleanliness is essential when working on hydraulic components.**

1. Remove the six socket head cap screws and pump displacement control valve (PDCV) from the pump housing.

*NOTE: The Pressure Control Pilot (PCP) (3) is serviced as an assembly. DO NOT disassemble.*

2. Remove cap (15) and valve spool (14). Replace O-ring.

3. Remove cap (6), spring (7), and valve spool (8). Replace O-ring.

4. Loosen adjusting screw (16) to release tension on spring (13).

5. Remove caps screws (12).

6. Lift linkage assembly (9, 10 and 11) with spring from housing.

*NOTE: Override linkage assembly (11) is not repairable. Do not disassemble.*

7. Clean and inspect parts.

8. Assemble parts (9—13).

9. Install valve spools, spring, O-rings and caps. Tighten caps to specifications.

**Hydrostatic Pump—Specification**

EDC Valve Spool	
Caps—Torque.....	11 N·m 96 lb-in.

T199990A—UN—17MAY04

## Hydrostatic System

10. Install new O-rings and Pressure Control Pilot (PCP). Tighten cap screws (2) to specifications.

### Hydrostatic Pump—Specification

Electronic Displacement	
Control-to-Control Valve	
Cap Screws—Torque.....	5.4 N·m 48 lb-in.

CED,OUO1008,149 -19-02OCT06-2/3

**IMPORTANT:** If system has been contaminated with debris, the screen filter (E) must be removed for cleaning of associated parts. Screen filters are not reusable, replace after removal, see parts catalog for replacement parts.

11. Inspect and clean screen filters (E) before installing displacement control valve (B).
12. Install gasket (A).

**IMPORTANT:** Linkage pin (C) must be installed correctly into link (D) or swash plate will not move.

13. Install displacement control valve (B) to pump making sure neutral feedback linkage pin (C) installs correctly into feedback link (D).
14. Install and tighten the six cap screws to specifications.

### Hydrostatic Pump—Specification

Displacement Control	
Valve-to-Hydrostatic	
Pump Cap	
Screws—Torque.....	16 N·m 144 lb-in.

**CAUTION:** After the displacement control valve has been disassembled, the tracks could rotate when park lock lever is lowered until null adjustment is preformed.

15. Perform pump displacement control valve neutral adjustment. See Pump Displacement Control Valve (PDCV) Neutral (Null) Adjustment. (Group 9026.)
16. Calibrate transmission control unit (TCU). See Transmission Control Unit (TCU) Calibration. (Group 9015.)

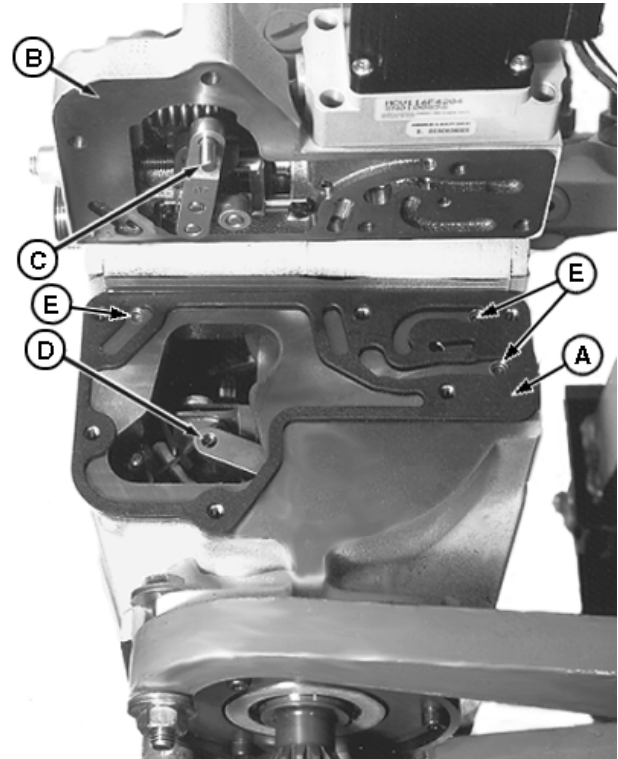

A—Gasket  
B—Displacement Control Valve  
C—Feedback Linkage Pin  
D—Feedback Link  
E—Screen Filter (3 used)

TX1012687A—UN—28SEP06

CED,OUO1008,149 -19-02OCT06-3/3

### Multi-Function Valve Disassemble and Assemble

1. Remove multi-function valves (1) from end cap.

1—Multi-Function Valve (2 used)

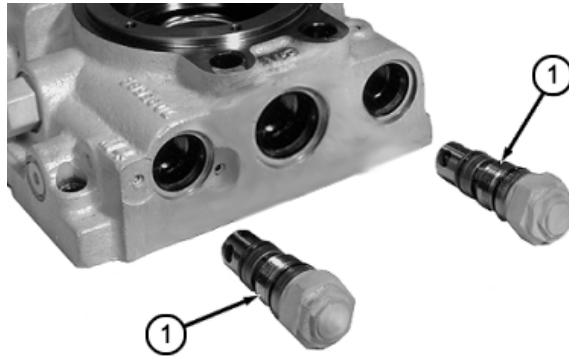

T200000A —UN—17MAY04

CED,OUO1004,521 -19-14MAY04-1/3

**⚠ CAUTION:** Multi-function valves contain springs under compression. Release spring tension by turning adjusting screw counter clockwise.

2. Use a small screw driver to separate multi-function valve body from poppet assembly.



T118409B —UN—17NOV98

Continued on next page

CED,OUO1004,521 -19-14MAY04-2/3

## Hydrostatic System

3. Carefully loosen cap (2) to release pressure on springs (7 and 12). Disassemble valve as shown.

4. Clean valve components and check for any contamination.

**NOTE:** Other than O-rings, multi-function valve components are not serviceable.

5. If any valve components are damaged, replace the entire valve.

6. Lubricate valve components with clean hydraulic oil.

7. Assemble multi-function valve. Use a vise to carefully press poppet assembly onto valve body. Tighten lock nut (1) to specification.

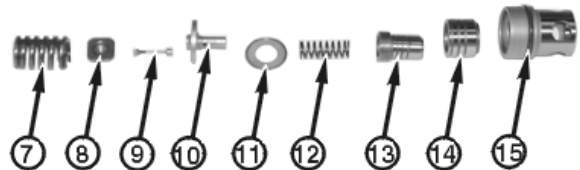
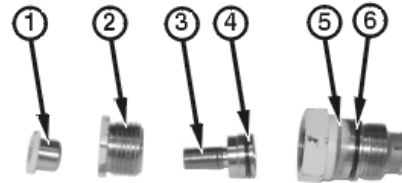

### Specification

Multi-Function Valve Lock

Nut—Torque.....16.3 N·m  
144 lb-in.

8. Check valve poppet movement in end of the multi-function valves.

9. Install and tighten multi-function valves to specifications.

### Hydrostatic Pump—Specification

Multi-Function

Valves—Torque.....79 N·m  
58 lb-ft

10. Perform multi-function relief valve test. (See Multi-Function Relief Valve Test. (Group 9026.)

- 1— Lock Nut
- 2— Cap
- 3— Bypass Piston
- 4— O-Ring
- 5— Valve Housing
- 6— O-Ring
- 7— Spring
- 8— Spring Guide

- 9— Pressure Limiter Poppet
- 10— Guide
- 11— Washer
- 12— Spring
- 13— High Pressure Relief Valve Poppet
- 14— Check Valve Poppet
- 15— O-Ring

11. Calibrate transmission control unit (TCU). See Transmission Control Unit (TCU) Calibration. (Group 9015.)

CED,OUO1004,521 -19-14MAY04-3/3

T119706B —UN—20JAN99

## Neutral Charge Relief Valve Disassemble and Assemble

1. Disconnect lines and remove relief valve from bottom of front hydrostatic pump. Note orientation of valve to aid in assembly.

2. Remove parts (2—8). Clean and inspect all parts for wear or damage.

3. Install new O-rings and assemble valve.

4. Perform Neutral Charge Relief and Operating Charge Relief Pressure Test. (Group 9026.)

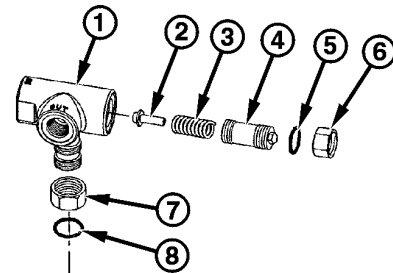

T119677B

- |                    |             |
|--------------------|-------------|
| 1— Valve Housing   | 5— O-Ring   |
| 2— Poppet          | 6— Lock Nut |
| 3— Spring          | 7— Lock Nut |
| 4— Adjusting Screw | 8— O-Ring   |

CED,OUO1004,523 -19-14MAY04-1/1

T119677B —UN—19JAN99

### Hydrostatic Pump Assemble

*NOTE: Apply clean hydrostatic oil to all internal parts before assembly*

**IMPORTANT: Components must be installed in proper position with original orientation to prevent premature pump failure. Bearing races must be completely seated in housing.**

**Inspect bearing cage wear patterns in bearing race and swash plate to determine remaining service life.**

1. Install bearing races (A) in housing.
2. Lubricate and install bearing cage on the bearing races.

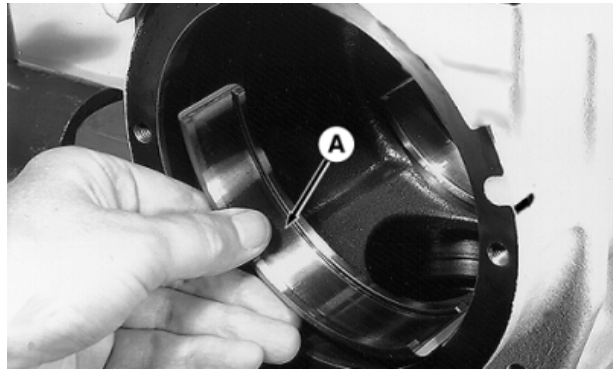

RW25758 —UN—16JUN97

A—Bearing Race (2 used)

TE14778,0000041 -19-22APR10-1/17

**IMPORTANT: Damage to polished surfaces can cause premature pump failure. Be careful when handling parts with polished surfaces to prevent nicks or scratches.**

*NOTE: Either side of slipper guide can be installed against slippers. Flip slipper guide if excessive wear is on top bearing surface.*

3. Inspect slipper guide surface, install smoothest side away from slippers.

Clean slipper guide bearing screw holes on swash plate surface using M8 tap.

*NOTE: Apply clean hydrostatic oil to all internal parts before assembly.*



Piston Assemblies

4. Install the piston assemblies into the slipper guide.
5. Apply clean hydrostatic oil on slippers. Center the pistons and guide on the swash plate.

T8464BL —UN—14JUN95

Continued on next page

TE14778,0000041 -19-22APR10-2/17

**IMPORTANT:** For correct assembly and to prevent premature wear, slipper guide bearing must be installed as shown.

The split between the slipper guide bearing plates must be located in line with the swash plate arm. The TEFLON® surface side of slipper guide bearing must be installed against the slipper guide.

6. Install first slipper guide bearing plate (C) with TEFLON® surface against the slipper guide (A) as shown.

**IMPORTANT:** To prevent premature pump failure, new slipper guide bearing plate cap screws must be installed. Install new cap screws whenever slipper guide bearing plates are removed.

7. Apply PM37418 thread lock and sealer (medium strength) on cap screw threads. Install new cap screws (D) through the slipper guide bearing and spacers (B) as shown. Finger tighten the cap screws into the swash plate.

A—Slipper Guide  
B—Spacer (4 used)

C—Slipper Guide Bearing (2 used)  
D—Cap Screw (4 used)

TEFLON is a trademark of Du Pont Co.

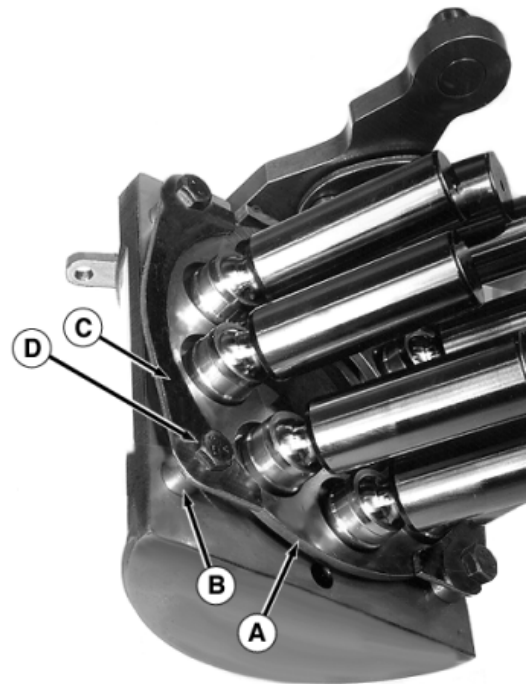

T121169 —UN—17APR99

TE14778,0000041 -19-22APR10-3/17

8. Tighten slipper guide bearing cap screws to specification.

Check movement of the assembly by hand. The slipper guide and piston slippers must slide freely on the swash plate.

**Hydrostatic Pump Swash Plate-to-Slipper Guide Bearing—Specification**

Cap Screw—Torque.....13.5 N·m  
120 lb·in.

9. Lubricate the pistons and cylinder block bores in clean hydraulic oil.



750J Slipper Guide Assembly Shown

T8464BQ —UN—14JUN95

Continued on next page

TE14778,0000041 -19-22APR10-4/17

**IMPORTANT: Wear patterns develop between cylinder block bores and pistons. Pistons must be installed in original cylinder block bores.**

10. Align pistons with original cylinder block bores and install assembly (A) in cylinder block (B).

A—Swash Plate and Piston Assembly      B—Cylinder Block Assembly



RW25746 —UN—12JUN97

TE14778,0000041 -19-22APR10-5/17

**IMPORTANT: Wear patterns develop between servo pistons and servo cylinders. Servo piston must be installed with original orientation.**

11. Install servo piston (A) into pump housing.  
12. Install bronze slider block (B) onto servo arm of swash plate assembly.

A—Servo Piston      B—Slider Block



RW25747 —UN—11JUN97

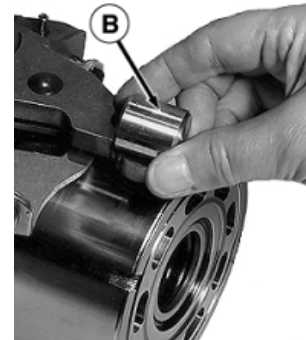

RW25748 —UN—11JUN97

Continued on next page

TE14778,0000041 -19-22APR10-6/17

**NOTE:** A second person will be needed to help align the slider block into the servo piston during swash plate installation.

A cap screw approximately 229 mm (9 in.) long, two flat washers 63 mm (2.5) OD and nut should be used to assist in lowering cylinder block into housing.

13. Lower swash plate and piston assembly partially into the pump housing.
14. Hold the assembly above the cradle bearings to correctly position the feedback link (C) in the control opening.
15. Align slider block (D) into the servo piston and continue to lower swash plate assembly into position on the bearings.
16. Remove the cap screw and washer used for cylinder block installation.
17. Check for clearance between the servo arm and slider block (D). If no clearance exists, recheck the assembly of the bearing cage and races.
18. Check to make sure swash plate assembly and servo piston slide freely.
19. Lubricate each of the internal bores of the servo cylinder with clean hydraulic oil.
20. Install O-rings on servo cylinder.

A—Piston Assembly                      C—Feedback Link  
 B—Assembled Cap Screw Tool      D—Bronze Slider Block

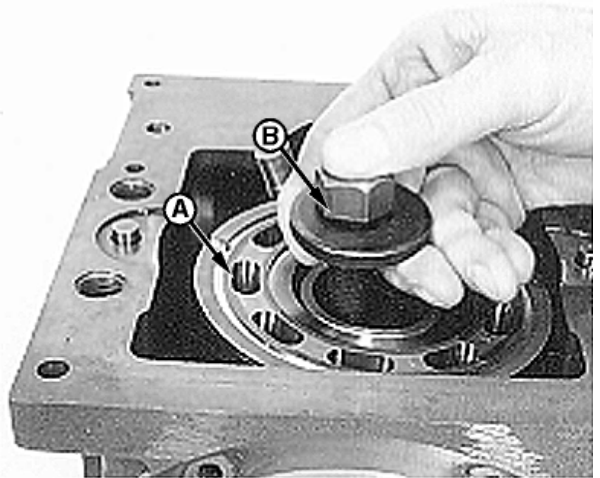

T118276 —UN—20NOV98

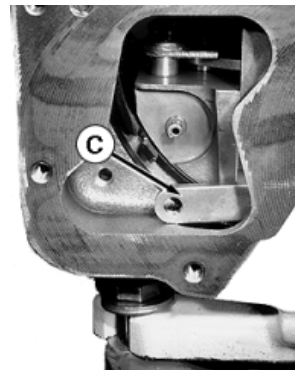

RW25754 —UN—12JUN97

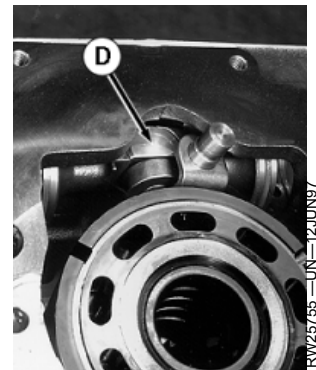

RW25755 —UN—12JUN97

TE14778,0000041 -19-22APR10-7/17

**IMPORTANT: Wear patterns develop between servo pistons and servo cylinders. Servo cylinders must be installed in original positions.**

21. Hold the servo piston in position and install the servo cylinders (A) into original bores.
22. Tighten the servo cylinder cap screws to specifications.

**Hydrostatic Pump—Specification**

Servo Cylinder Cap	
Screws—Torque.....	33 N·m 24 lb·ft

23. Move the swash plate to align the spring pin in the swash plate with the slot in the swash plate bearing cage and the pin hole in the housing.
24. Install cage locator link (B) and locator link pin (C).

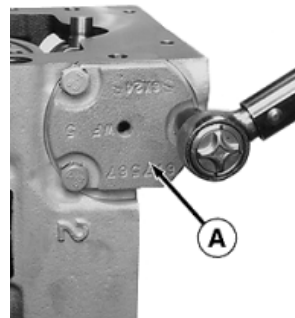

RW25756 —UN—12JUN97

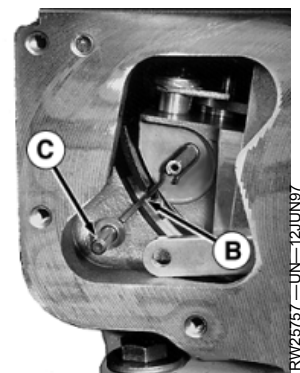

RW25757 —UN—12JUN97

A—Servo Cylinder  
 B—Locator Link

C—Locator Link Pin

Continued on next page

TE14778,0000041 -19-22APR10-8/17

**IMPORTANT: T-Bar must be positioned on top of swash plate.**

25. Install O-ring on side cover.
26. Install side cover (A) to pump housing making sure O-ring is not damaged during installation.
27. Align side cover and pump housing with mark (B).
28. Install two new cap screws (C) as illustrated to hold cover. Do not fully tighten the cap screws.
29. Install leveling springs (D) and swash plate hold-down spring (E).

A—Side Cover	D—Swash Plate Leveling Spring (2 used)
B—Alignment Mark	E—Swash Plate Hold-Down Spring
C—Cap Screw (2 used)	

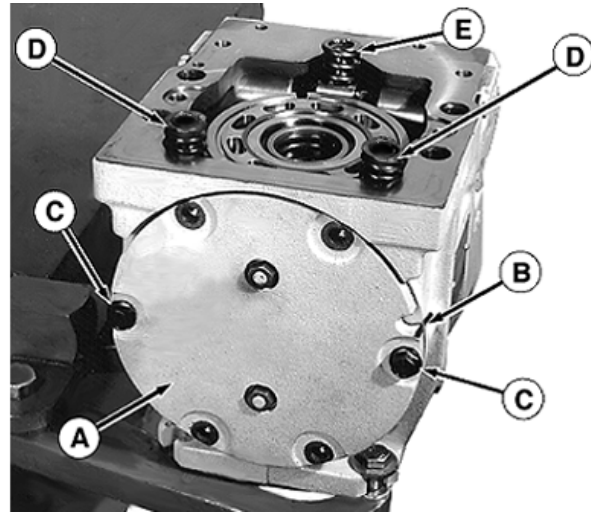

T156777B—UN—27JUN02

TE14778,0000041 -19-22APR10-9/17

30. Install JDG1094 Leveling Plate (A) to pump housing making sure spring pockets (B) are correctly aligned with springs (C).
31. Install and tighten cap screws (D).

A—JDG1094 Leveling Plate	C—Leveling Spring (3 used)
B—Spring Pocket (3 used)	D—Cap Screw (2 used)

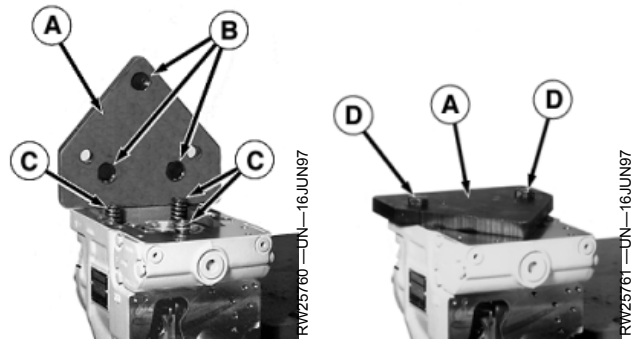

RW25760—UN—16JUN97

RW25761—UN—16JUN97

TE14778,0000041 -19-22APR10-10/17

**IMPORTANT: The base of the depth micrometer must be positioned on top of the JDG1094 Leveling Plate when measuring zero angle position of the swash plate.**

**The rod must be located on the swash plate and NOT on the piston retainer plate.**

*NOTE: Depth gauge must have capability of measuring approximately 100—127 mm (4—5 in.).*

32. Measure the zero angle position of the swash plate using a depth micrometer as illustrated making sure the end of the micrometer rod (A) is contacting the swash plate flat surface (B).
33. Measure the other side of swash plate at (C).

**IMPORTANT: Measurements must not vary more than 0.025 mm (0.001 in.) on either side of the swash plate.**

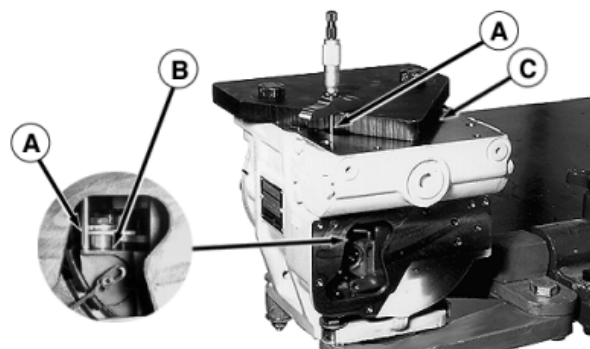

A—Depth Micrometer	C—Opposite Measuring Location
B—Swash Plate Flat Surface	

RW25762—UN—16JUN97

34. Take a second measurement on each side.

Continued on next page

TE14778,0000041 -19-22APR10-11/17

## Hydrostatic System

35. Rotate the side cover at location (D) as necessary to obtain zero angle position of swash plate.

36. Once zero angle position has been established. Tighten the two side cover screws (E) to specifications.

### Hydrostatic Pump—Specification

Side Cover-to-Pump	
Housing Blind Hole Cap	
Screws—Torque.....	33 N·m 24 lb-ft

37. Install the remaining new four side cover cap screws to specifications.

### Hydrostatic Pump—Specification

Side Cover-to-Pump	
Housing Through	
(Top Two) Hole Cap	
Screws—Torque.....	33 N·m 24 lb-ft

38. Recheck zero angle position to verify side cover did not move while torquing the four side cover cap screws (E).

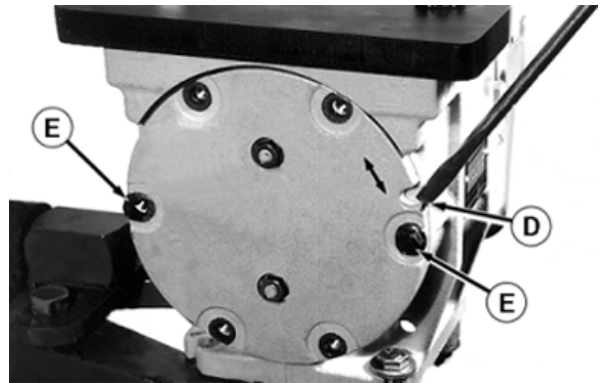

T118274 —UN—17NOV98

**D—Side Cover Rotation      E—Cap Screw (4 used)**

39. Remove leveling plate.

TE14778,0000041 -19-22APR10-12/17

40. Install two alignment pins (A).

41. Lubricate the running surface of the cylinder block.

*NOTE: Make sure valve plate (B) and gasket (D) do not get caught on alignment pins (A) during installation.*

*NOTE: The arrow cut-outs in the valve plate must point in the direction of pump rotation when viewed from the shaft end.*

42. Install valve plate (B) making sure the direction arrows (C) stamped in the valve plate are correctly positioned.

43. Install gasket (D).

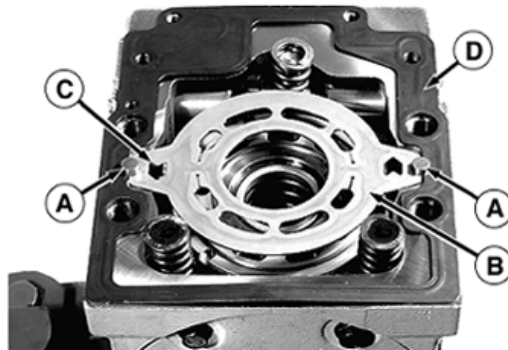

T1156793B —UN—27JUN02

**A—Alignment Pin (2 used)      C—Directional Arrow (2 used)**  
**B—Valve Plate                      D—Gasket**

Continued on next page

TE14778,0000041 -19-22APR10-13/17

## Hydrostatic System

**IMPORTANT: Use hardened swash plate leveler spring shims only. Using other materials for shims may result in damage to pump.**

44. Install the leveler spring shims (A) in the end cap pockets using petroleum jelly to hold shims.
45. Lubricate the end cap journal bearing (B) with clean hydraulic oil.

**A—Leveler Spring Shim (2 used)      B—End Cap Journal Bearing**

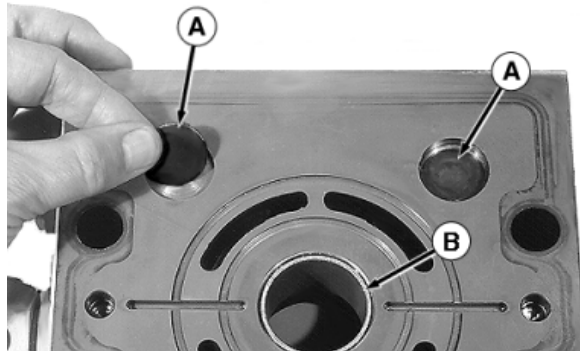

RW25765 —UN—20JUN97

TE14778,0000041 -19-22APR10-14/17

46. Install the end cap to the pump housing making sure springs align with the end cap pockets.
47. Install O-ring, new adapter plate (1), and socket head cap screws (2). Tighten cap screws to specifications.

**Hydrostatic Pump—Specification**

End Cap/Adapter-to-Pump Cap Screws (Large)—Torque.....	298 N·m 220 lb-ft
--	----------------------

48. Install socket head cap screw (3) with spacer and lifting bracket and cap screw (4). Tighten to specifications.

**Hydrostatic Pump—Specification**

End Cap-to-Pump Cap Screws (Small)—Torque.....	33 N·m 24 lb-ft
--	--------------------

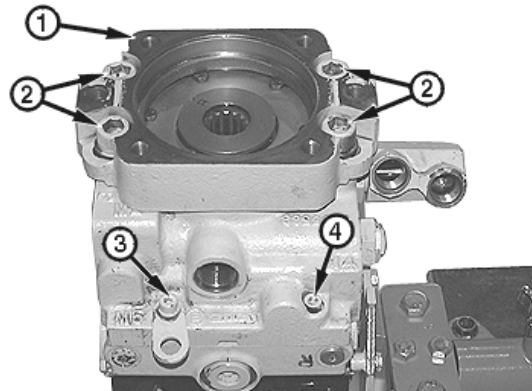

T119614B —UN—15JAN99

**1—Adapter Plate      3—Socket Head Cap Screw with Spacer and Lift Bracket**  
**2—Socket Head Cap Screws (4 used)      4—Socket Head Cap Screw**

TE14778,0000041 -19-22APR10-15/17

49. Turn the pump 180° to install the shaft.
50. Install the shaft and bearing assembly.
51. Rotate the shaft to insure the rotating assembly turns freely.



RW25767 —UN—20JUN97

Continued on next page

TE14778,0000041 -19-22APR10-16/17

Hydrostatic System

- 52. Carefully install seal carrier (A) with lip seal.
- 53. Install retaining plate (B) and socket head cap screws (C). Tighten to specifications.

**Hydrostatic Pump—Specification**

Input Shaft Seal	
Carrier Retaining Cap	
Screw—Torque.....	16 N·m 144 lb-in.

- 54. Install displacement control valve assembly.  
See Pump Displacement Control Valve (PDCV)  
Disassemble and Assemble. (Group 0360.)

**A—Seal Carrier**                      **C—Socket Head Cap Screw (3 used)**  
**B—Retaining Plate**

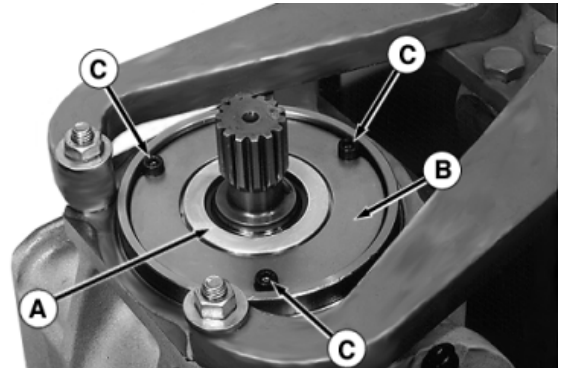

RW25768 — UN — 20JUN97

TE14778,0000041 -19-22APR10-17/17

### Hydrostatic Motor Disassemble

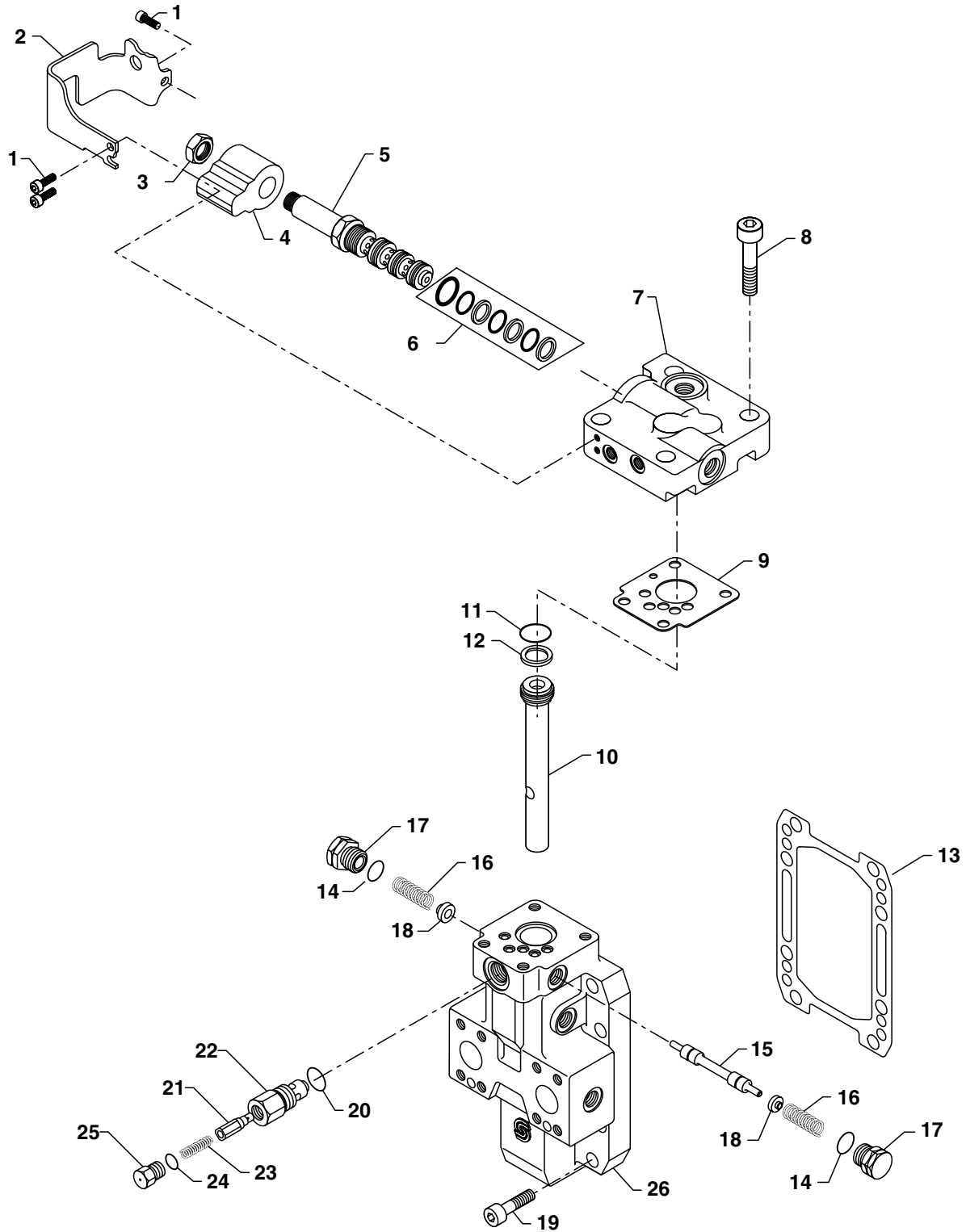

T198858

Hydrostatic Motor Control Valve

T198858—UN—03MAY04

Continued on next page

TE14778,000001F -19-02OCT06-1/8

## Hydrostatic System

- |   |   |   |  |
|---|---|---|--|
| 1— Hex Socket Head Cap Screw (3 used)<br>2— Bracket<br>3— Nut<br>4— Solenoid Valve Coil<br>5— Solenoid Valve Spool<br>6— Solenoid Valve O-ring Kit<br>7— Solenoid Valve Housing | 8— Hex Socket Head Cap Screw (4 used)<br>9— Gasket<br>10— Servo Piston<br>11— O-ring<br>12— V-ring<br>13— Gasket<br>14— O-ring (2 used) | 15— Flushing Valve Spool<br>16— Spring (2 used)<br>17— Plug Fitting (2 used)<br>18— Spring Plate (2 used)<br>19— Hex Socket Head Cap Screw (8 used)<br>20— O-ring<br>21— Poppet Valve | 22— Operating Charge Relief Valve Housing<br>23— Spring<br>24— O-ring<br>25— Plug Fitting<br>26— End Cap Housing |
|---|---|---|--|

1. Thoroughly clean external surface of motor prior to disassembly.
2. Scribe a line between hydrostatic motor control valve and rotating group housing to aid in assembly.
3. Remove eight hex socket head cap screws (19) and hydrostatic motor control valve from rotating group housing
4. Remove four hex socket head cap screws (8) and motor shift solenoid valve housing (7) from end cap housing (26).

TE14778.000001F -19-02OCT06-2/8

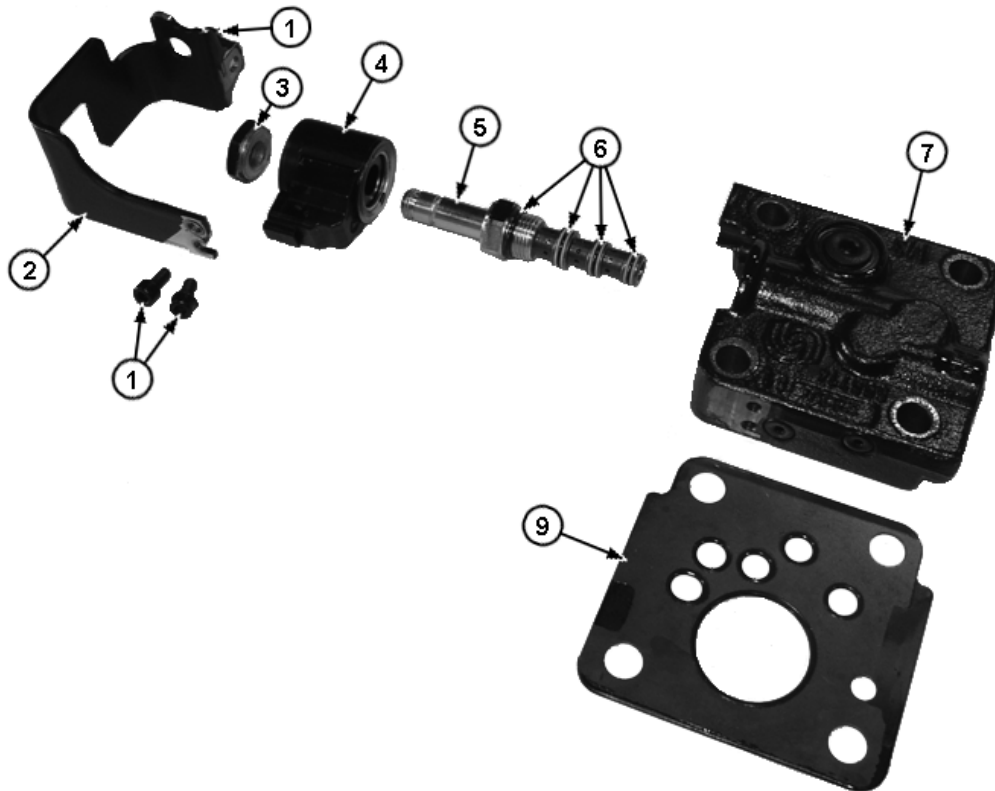

- |   |                                  |   |  |
|---|----------------------------------|---|--|
| 1— Hex Socket Head Cap Screw (3 used)<br>2— Bracket | 3— Nut<br>4— Solenoid Valve Coil | 5— Solenoid Valve Spool<br>6— Solenoid Valve O-ring Kit | 7— Solenoid Valve Housing<br>9— Gasket |
|---|----------------------------------|---|--|

5. Disassemble motor shift solenoid valve as shown.
6. Disassemble solenoid valve O-ring kit (6) from solenoid valve spool.

Continued on next page

TE14778.000001F -19-02OCT06-3/8

T198886A—UN—07MAY04

Hydrostatic System

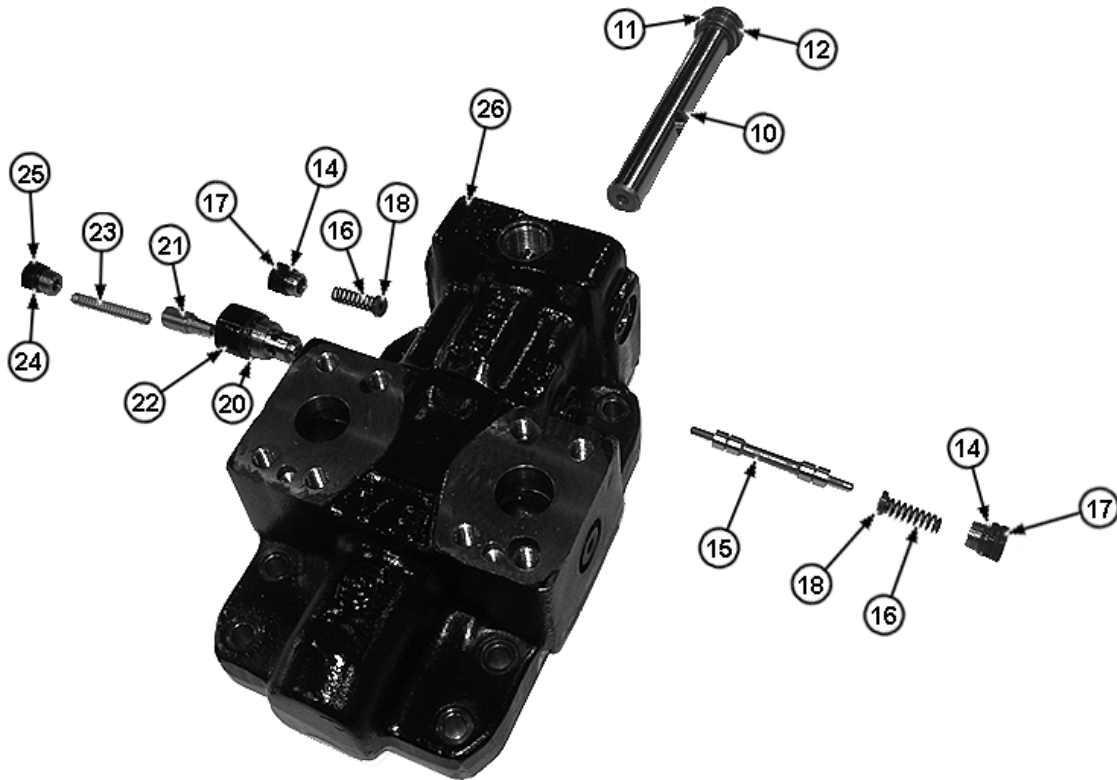

- |                     |                           |   |                     |
|---------------------|---------------------------|---|---------------------|
| 10— Servo Piston    | 15— Flushing Valve Spool  | 20— O-Ring                                | 24— O-Ring          |
| 11— O-Ring          | 16— Spring (2 used)       | 21— Poppet Valve                          | 25— Plug Fitting    |
| 12— V-Ring          | 17— Plug Fitting (2 used) | 22— Operating Charge Relief Valve Housing | 26— End Cap Housing |
| 14— O-Ring (2 used) | 18— Spring Plate (2 used) | 23— Spring                                |                     |

7. Disassemble end cap assembly as shown.

Continued on next page

TE14778,000001F -19-02OCT06-4/8

T198903A—UN—07MAY04

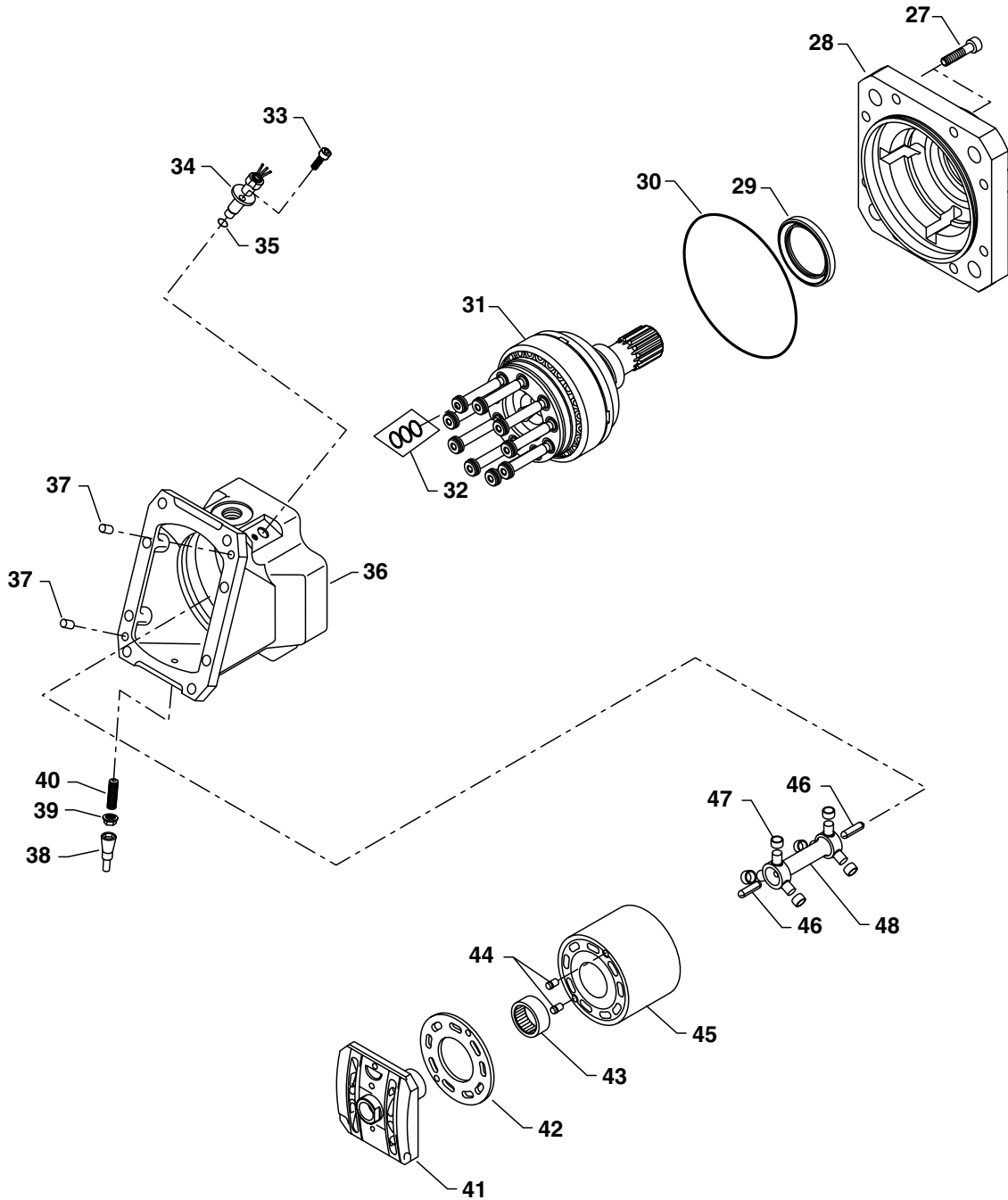

T198860

Rotating Group Assembly

Continued on next page

TE14778.000001F -19-02OCT06-5/8

T198860 -JUN-03MAY04

## Hydrostatic System

27— Hex Socket Head Cap Screw (8 used)	33— Hex Socket Head Cap Screw	39— Nut	45— Cylinder Block
28— Flange	34— Speed Sensor	40— Set Screw	46— Synchronizer Shaft Support Pin (2 used)
29— Seal	35— O-ring	41— Valve Segment	47— Synchronizer Shaft Roller (6 used)
30— O-ring	36— Rotating Group Housing	42— Bearing Plate	48— Synchronizer Shaft
31— Shaft Assembly	37— End Cap Housing Alignment Pin (2 used)	43— Cylinder Block Bearing	
32— Seal Kit	38— Cap	44— Cylinder Block Alignment Pin (2 used)	

**IMPORTANT:** Special attention should be given to the orientation of the valve segment (41) with end cap and housing (26), cylinder block alignment pins (44), synchronizer shaft rollers (47) with synchronizer shaft (recess faces the centerline of the shaft) and synchronizer shaft (48) with cylinder block (45) and output shaft.

8. Remove hydrostatic motor parts (41—48).

9. Remove socket head cap screw (33) and motor speed sensor (34) from rotating group housing (36).
10. Scribe a line on housing and flange to aid in assembly. Remove eight socket head cap screws (27) from flange. Remove flange from rotating group housing.
11. Remove old seal (29) from flange. Once removed, the seal is not reusable.

TE14778,000001F -19-02OCT06-6/8

12. Pull shaft assembly out of main housing, taking care not to damage the shaft and speed sensor ring. DO NOT damage pistons. Use attachments from the D01173AA 17-1/2 Ton Puller Set and JT01800 Driver Set.

13. Remove seal kit (32) from pistons using a small pair of retaining ring pliers and an O-ring pick.



T199010A—JUN—01APR04

Continued on next page

TE14778,000001F -19-02OCT06-7/8

**IMPORTANT: Remove speed ring ONLY if replacement is necessary.**

**DO NOT damage sealing surface of cylinder block.**

14. If required, remove speed ring (1) from shaft assembly by gently tapping on ring using a hammer and brass drift.
15. Clean and rotating group components. Replace as required.

1— Speed Ring

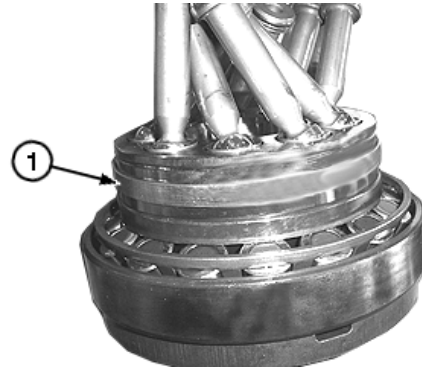

TX1012509A —UN—22SEP06

TE14778,000001F -19-02OCT06-8/8

### Hydrostatic Motor Assemble

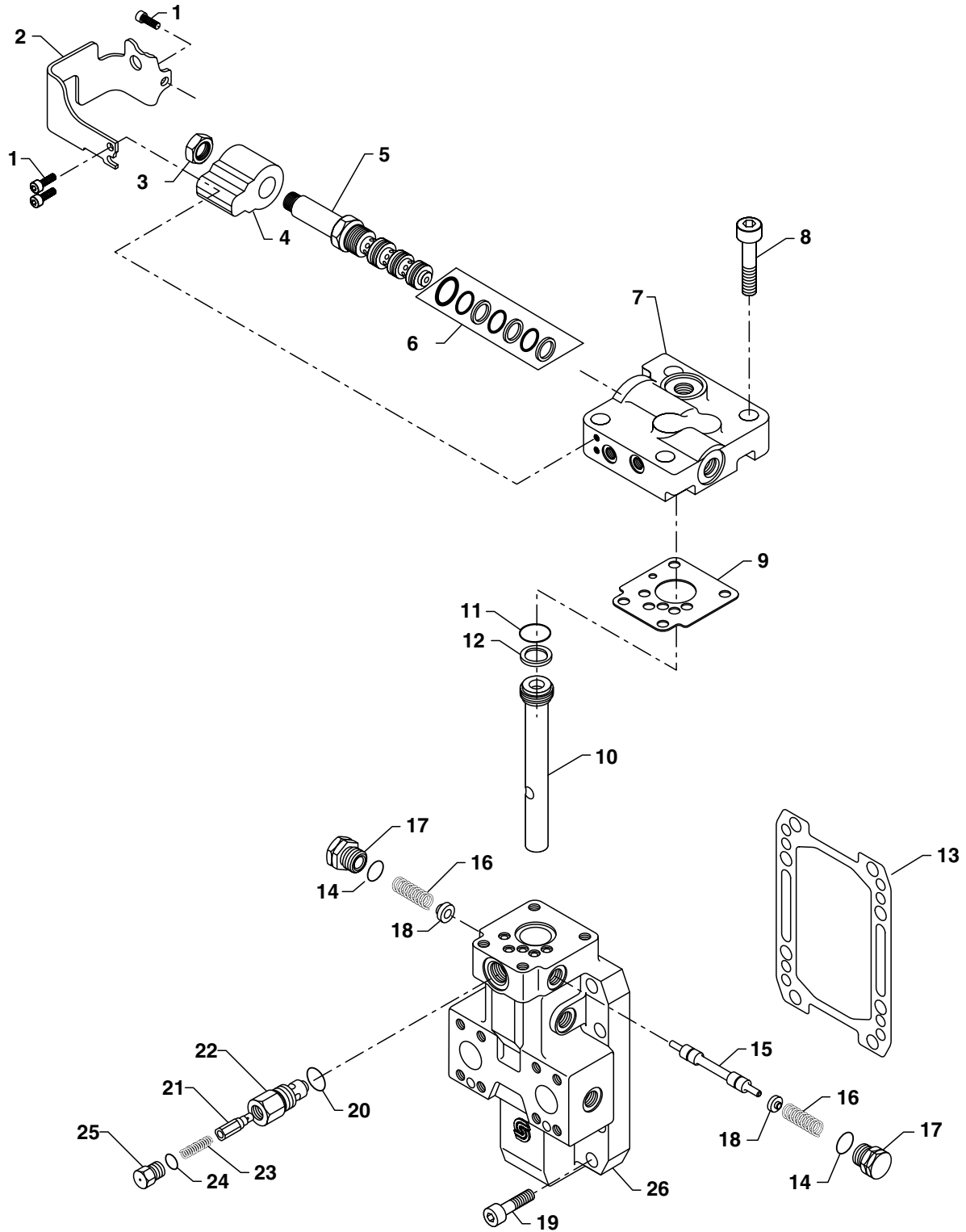

T198858

Hydrostatic Motor Control Valve

T198858—UN—03MAY04

Continued on next page

TE14778,0000020 -19-21JUL09-1/13

## Hydrostatic System

- |  |  |  |   |
|--|--|--|---|
| 1— Hex Socket Head Cap Screw<br>(3 used)<br>2— Bracket<br>3— Nut<br>4— Solenoid Valve Coil<br>5— Solenoid Valve Spool<br>6— Solenoid Valve O-Ring Kit<br>7— Solenoid Valve Housing | 8— Hex Socket Head Cap Screw<br>(4 used)<br>9— Gasket<br>10— Servo Piston<br>11— O-Ring<br>12— V-Ring<br>13— Gasket<br>14— O-Ring (2 used) | 15— Flushing Valve Spool<br>16— Spring (2 used)<br>17— Plug Fitting (2 used)<br>18— Spring Plate (2 used)<br>19— Hex Socket Head Cap Screw<br>(8 used)<br>20— O-Ring<br>21— Poppet Valve | 22— Operating Charge Relief<br>Valve Housing<br>23— Spring<br>24— O-Ring<br>25— Plug Fitting<br>26— End Cap Housing |
|--|--|--|---|

*NOTE: Apply clean hydrostatic oil to all internal parts prior to assembly.*

1. Clean and inspect parts.
2. Install new solenoid valve O-ring kit (6) on solenoid valve spool (5).
3. Install solenoid valve spool with O-rings in solenoid valve housing (7). Tighten to specification.

**Specification**

Solenoid Valve Spool—Torque.....	30 N·m 22 lb.-ft.
----------------------------------	----------------------

4. Install solenoid valve coil (4) in position as marked during removal.
5. Assemble nut (3) and tighten to specification.

**Specification**

Solenoid Valve Nut—Torque.....	6 N·m 53 lb.-in.
--------------------------------	---------------------

6. Assemble bracket (2) with hex socket head cap screws (1) and tighten to specification.

**Specification**

Bracket Hex Socket Head Cap Screw—Torque.....	15.3 N·m 11.3 lb.-in.
---	--------------------------

7. Install V-ring (12) and O-ring (11) onto servo piston (10). Install servo piston into end cap housing (26).
8. Install flushing valve spool (15) into end cap housing (26).

9. Install O-ring (14) onto plug fitting (17).
10. Install spring plate (18), spring (16), and plug fitting (17) into end cap housing (26). Tighten plug fitting to specification.

**Specification**

Flushing Valve Plug Fitting—Torque.....	37 N·m 27 lb.-ft.
---	----------------------

Repeat installation of spring plate, spring, O-ring, and plug fitting on other side.

11. Install O-ring (24) onto plug fitting (25).
12. Install poppet valve (21), spring (23), and plug fitting (25) into operating charge relief valve housing (22). Tighten plug fitting to specification.

**Specification**

Operating Charge Relief Valve Plug Fitting—Torque.....	37 N·m 27 lb.-ft.
--	----------------------

13. Install O-ring (20) onto operating charge relief valve housing (22). Install relief valve into end cap housing (26) and tighten to specification.

**Specification**

Operating Charge Relief Valve—Torque.....	52 N·m 38 lb.-ft.
---	----------------------

Continued on next page

TE14778.0000020 -19-21JUL09-2/13

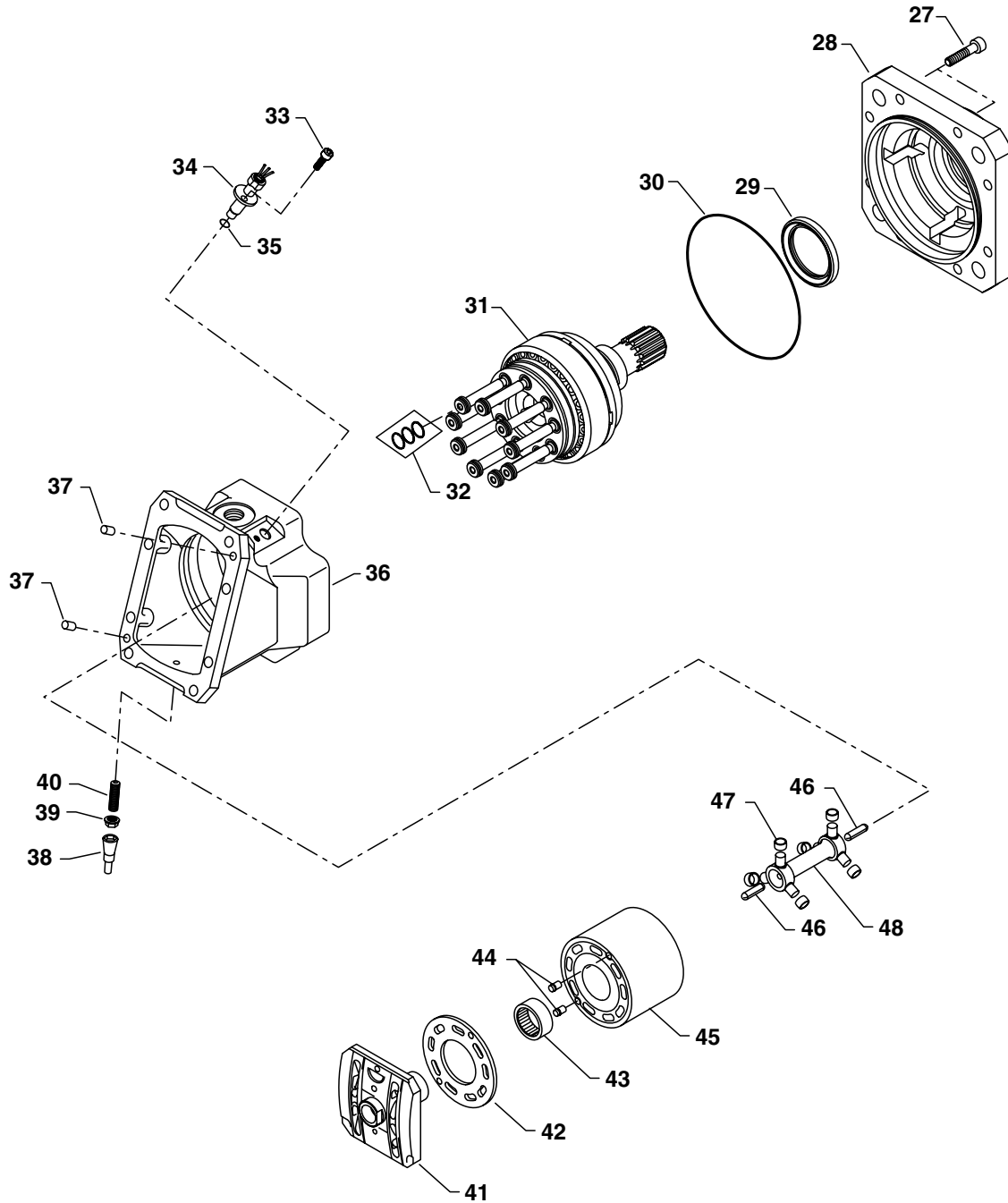

T198860

Rotating Group Assembly

T198860—UN—03MAY04

Continued on next page

TE14778,0000020 -19-21JUL09-3/13

Hydrostatic System

27— Hex Socket Head Cap Screw (8 used)	33— Hex Socket Head Cap Screw	39— Nut	45— Cylinder Block
28— Flange	34— Speed Sensor	40— Set Screw	46— Synchronizer Shaft Support Pin (2 used)
29— Seal	35— O-Ring	41— Valve Segment	47— Synchronizer Shaft Roller (6 used)
30— O-Ring	36— Rotating Group Housing	42— Bearing Plate	48— Synchronizer Shaft
31— Shaft Assembly	37— End Cap Housing Alignment Pin (2 used)	43— Cylinder Block Bearing	
32— Seal Kit	38— Cap	44— Cylinder Block Alignment Pin (2 used)	

14. Install new seal kit (32) on pistons.

*NOTE: Shaft assembly (31) with exception of the seal kit (32) is serviced as an assembly.*

Continued on next page

TE14778,0000020 -19-21JUL09-4/13

15. Inspect the bronze surface of the bearing plate (42) for damage and excessive wear. The sealing surfaces must be free from scratches and nicks. The cylinder block alignment pin (44) holes must not be worn. Replace the bearing plate if damaged or worn.

16. Inspect the valve segment (41) sealing surfaces and spindle (50) for damage or wear. Check that the spindle is located correctly in the valve segment by measuring dimension "A." If this dimension is not within the specification, the spindle has moved in the valve segment and the assembly must be replaced.

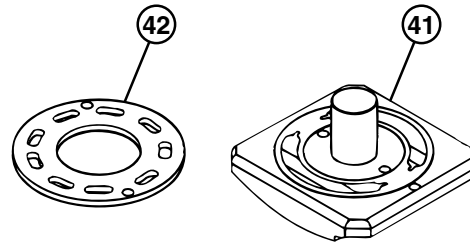

**Specification**

Valve Segment Spindle	
Dimension "A"—Length.....	39.4—39.6 mm 1.55—1.56 in.

**IMPORTANT: DO NOT damage sealing surface of cylinder block.**

17. Inspect cylinder block (45) for wear or damage. The piston bores must be smooth. The bearing plate surface must be free from scratches or nicks, and the holes for the end cap housing alignment pins (37) must not be worn. The races for the synchronizer shaft rollers must not be worn.

18. Inspect cylinder block bearing (43). If it requires replacement, remove bearing using a suitable puller. DO NOT damage the bearing plate surface of the cylinder block.

Press a new bearing (if removed) into the cylinder block until it is located at the proper distance (dimension "B") below the bearing plate.

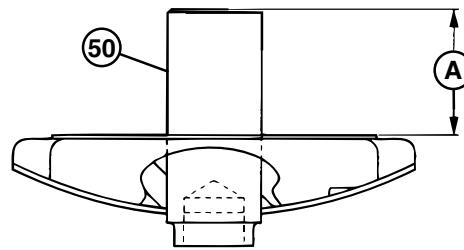

**Specification**

Cylinder Block Bearing	
Dimension "B"—Depth.....	14.5—15.0 mm 0.57—0.59 in.

19. Place shaft assembly on a clean soft surface (cardboard or shop towel) to replace speed ring. Be careful NOT to damage sealing surface of shaft assembly.

20. Place new speed ring on piston side of shaft assembly.

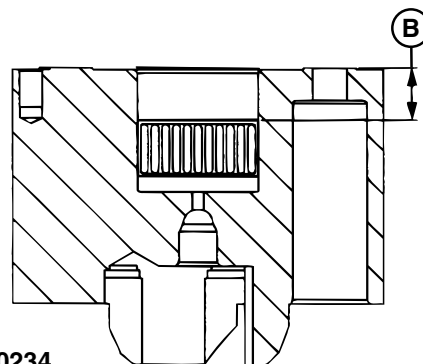
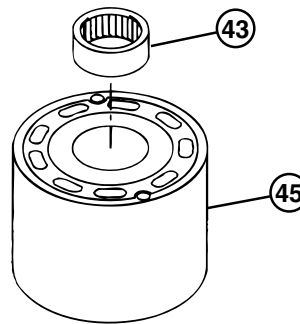

- 41— Valve Segment
- 42— Bearing Plate
- 43— Cylinder Block Bearing
- 44— Cylinder Block
- 50— Spindle
- A—Dimension "A"
- B—Dimension "B"

T200234

Valve Segment Spindle

T200234 —UN—20MAY04

Continued on next page

TE14778,0000020 -19-21JUL09-5/13

**IMPORTANT: To prevent damage to speed ring use installation tool JDG1332 Speed Ring Installer.**

21. Carefully place JDG1332 Speed Ring Installer over shaft assembly pistons. Alternately tap edge of installer using a rubber mallet to seat speed ring. Speed ring will be located correctly when installer is bottomed on shaft assembly.

1— Speed Ring

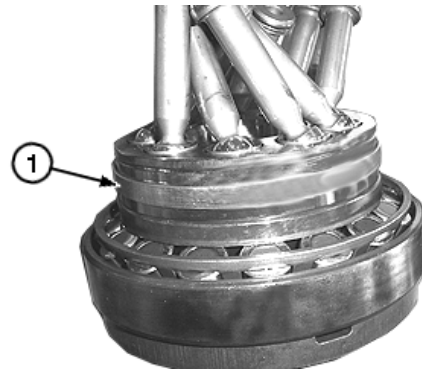

*Speed Ring Shown Installed*

Continued on next page

TE14778,0000020 -19-21JUL09-6/13

TX1012509A —UN—22SEP06

**NOTE:** Apply clean hydrostatic oil to all internal parts prior to assembly.

22. Position motor shaft assembly (31) in rotating group housing (36). Align scribe mark between housing and flange (28). Install flange over motor shaft assembly as far as possible.

Install two screws (M12 x 65 mm) 180° apart on flange. Alternately tighten screws until bottomed to seat flange and motor shaft assembly. Remove two 65 mm (2.56 in.) screws and repeat procedure using 50 mm (1.97 in.) screws. Remove screws.

Install eight hex socket head cap screws (27). Alternately tighten screws to seat motor shaft assembly and flange against housing. Torque screws to specification.

**Specification**

Flange-to-Motor Housing	
Cap Screw—Torque.....	110 N·m 81 lb.-ft.

- |  |                            |
|--|----------------------------|
| 29— Seal                               | 30— O-Ring                 |
| 27— Hex Socket Head Cap Screw (8 used) | 31— Shaft Assembly         |
| 28— Flange                             | 36— Rotating Group Housing |

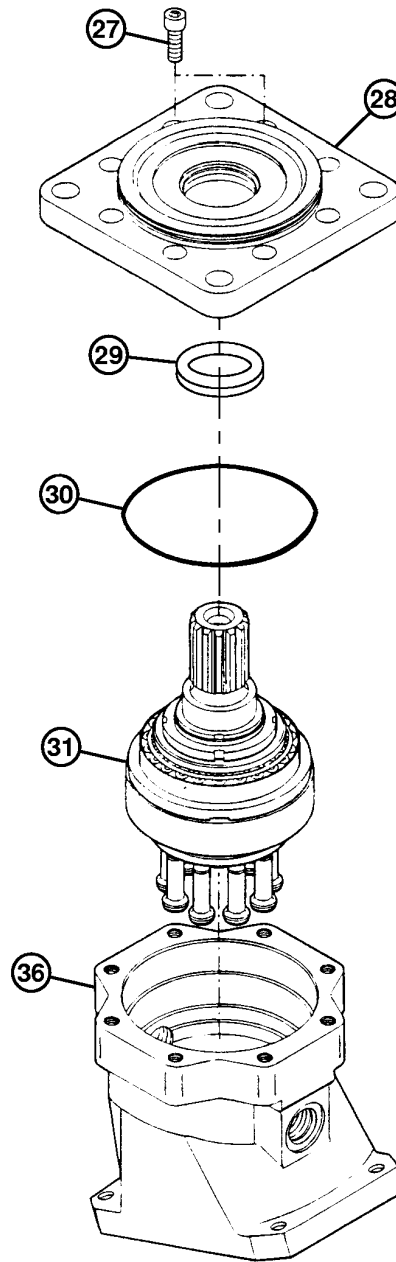

**T200220**

Shaft Assembly

T200220—UN—21MAY04

Continued on next page

TE14778,0000020 -19-21JUL09-7/13

23. Install synchronizer shaft support pin (46) into the shaft assembly (31) and retain with petroleum jelly.
24. Install the synchronizer shaft rollers (47) on the journals of the synchronizer shaft (48) and retain with petroleum jelly. Position each synchronizer shaft roller with its outside edge even with the end of the synchronizer shaft journal.

**IMPORTANT: Install synchronizer shaft correctly.**  
**The cylinder block end of the shaft is larger than the motor shaft end. Internal machine damage can occur.**

25. Install the synchronizer shaft and synchronizer shaft rollers into the motor shaft assembly.
26. The synchronizer shaft rollers must enter the races in the motor shaft insert, and the recess in the end of the synchronizer shaft must engage the synchronizer shaft support pin.

Tip and rotate the synchronizer shaft in all directions to check for binding. The synchronizer shaft rollers must move freely in the races in the motor shaft insert.

- |  |   |
|--|---|
| 31— Shaft Assembly                             | 47— Synchronizer Shaft Roller<br>(6 used) |
| 46— Synchronizer Shaft<br>Support Pin (2 used) | 48— Synchronizer Shaft                    |

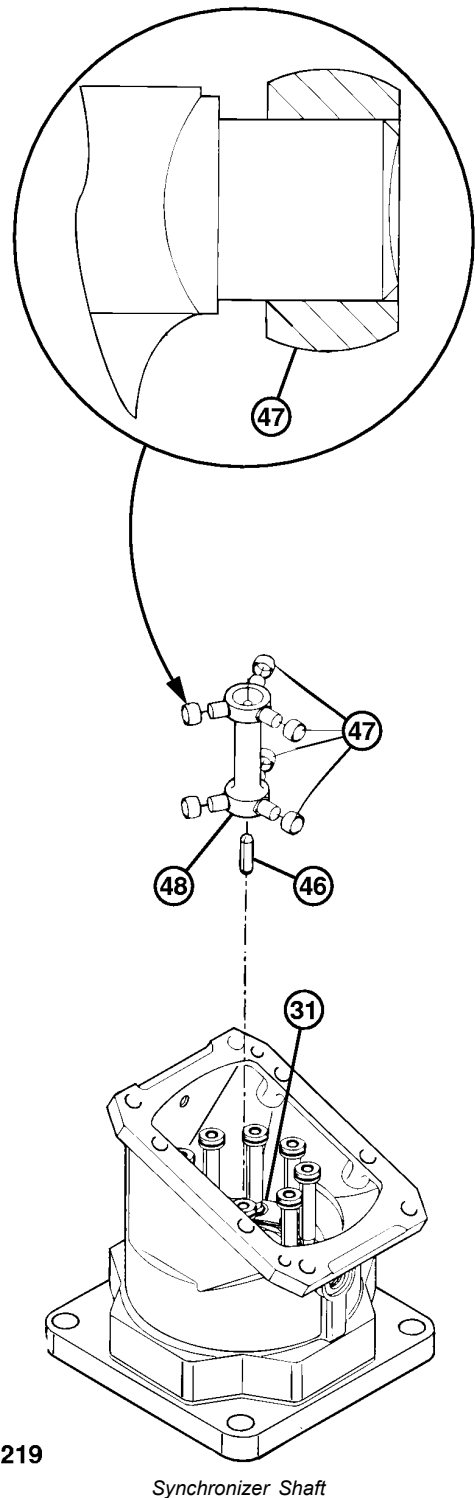

T200219

Synchronizer Shaft

Continued on next page

TE14778,0000020 -19-21JUL09-8/13

T200219 —UN—27MAY04

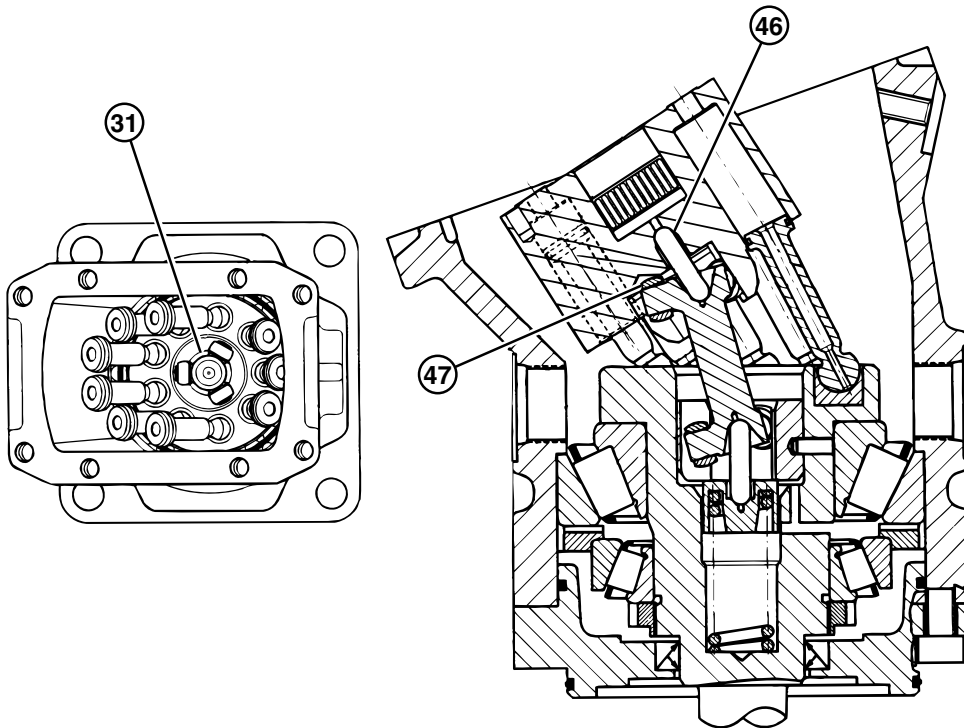

T200218

Cylinder Block

- 31— Synchronizing Shaft      46— Synchronizer Shaft Support Pin (2 used)      47— Synchronizer Shaft Roller (6 used)

27. Position the synchronizing shaft in the housing as shown. Tip the three pistons closest to the highest side of housing.

T200218 —UN—20MAY04

TE14778,0000020 -19-21JUL09-9/13

28. Install the second synchronizer shaft support pin (46) into the recess of the cylinder block and retain with petroleum jelly.

**IMPORTANT: Install cylinder block correctly. The cylinder block must be positioned so the synchronizer shaft rollers will enter their races in the block, while each piston enters its corresponding bore in the block. Internal machine damage can occur.**

29. With the synchronizing shaft supported in the shaft assembly, install the cylinder block (45) and its synchronizer shaft support pin (46) onto the pistons and synchronizer shaft.

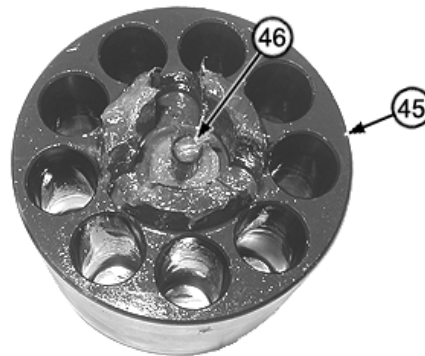

Support Pin

- 45— Cylinder Block      46— Synchronizer Shaft Support Pin (2 used)

T200221A —UN—20MAY04

Continued on next page

TE14778,0000020 -19-21JUL09-10/13

*NOTE: A brass rod may be inserted through the cylinder block to guide the pistons into position.*

30. Start with the six pistons closest to the lower part of the end cap mounting surface. After the six pistons enter their bores, tilt the cylinder block so the synchronizer shaft rollers (47) enter their races in the cylinder block, and the support pin enters its recess in the synchronizer shaft.

*NOTE: Apply clean hydrostatic oil to all cylinder block bores.*

31. Lift the cylinder block slightly and guide the three remaining pistons into their bores.

After the last piston is in position, check the position of the rollers at highest side of housing. Maintain an inward force on the cylinder block and carefully push it toward the highest part of the housing to check that all synchronizer shaft rollers are in position.

If cylinder block is properly assembled, there will be very little (if any) rotational free play between the block and the motor shaft.

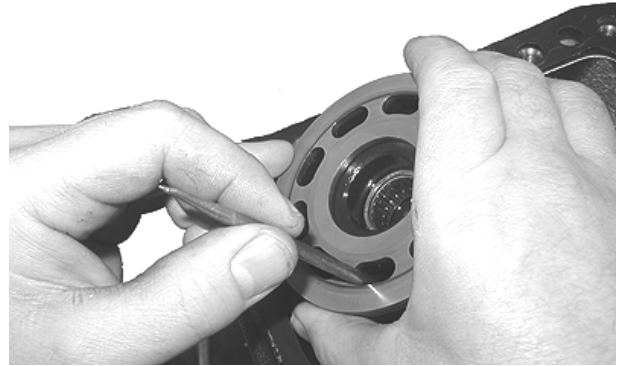

Cylinder Block Assembly

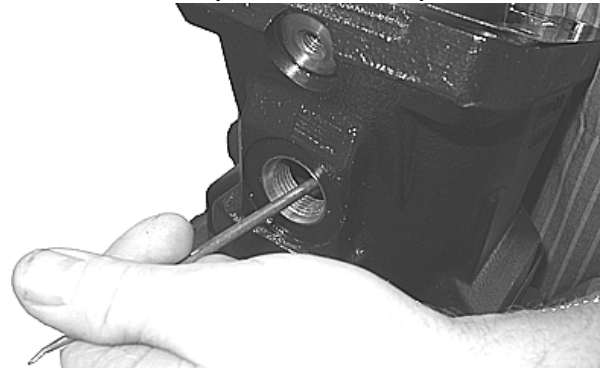

Cylinder Block Assembly

T200222A —UN—20MAY04

T200223A —UN—20MAY04

Continued on next page

TE14778,0000020 -19-21JUL09-11/13

32. Install the cylinder block alignment pins (44) into cylinder block. The longer end of each shouldered pin is installed into block.
33. Install the bearing plate (42) on the cylinder block with the steel side facing toward the block. Lubricate the bronze side of the plate with clean hydrostatic oil.
34. Install end cap housing alignment pin (37) and gasket (13). Carefully locate the cylinder block against highest part of housing.

**IMPORTANT: DO NOT allow the pistons or synchronizer shaft rollers to fall out of position. Internal machine damage can occur.**

35. Apply petroleum jelly to mating surfaces of valve segment and end cap. Install the valve segment (41), with hole (49) on opposite side of speed sensor, into the end cap housing (26) so the spindle engages the setting lug in the servo piston. Locate the valve segment and servo piston in the approximate center of its travel.

- |                        |                              |
|------------------------|------------------------------|
| 13— Gasket             | 42— Bearing Plate            |
| 26— End Cap Housing    | 44— Cylinder Block Alignment |
| 37— End Cap Housing    | Pin (2 used)                 |
| Alignment Pin (2 used) | 49— Hole                     |
| 41— Valve Segment      |                              |

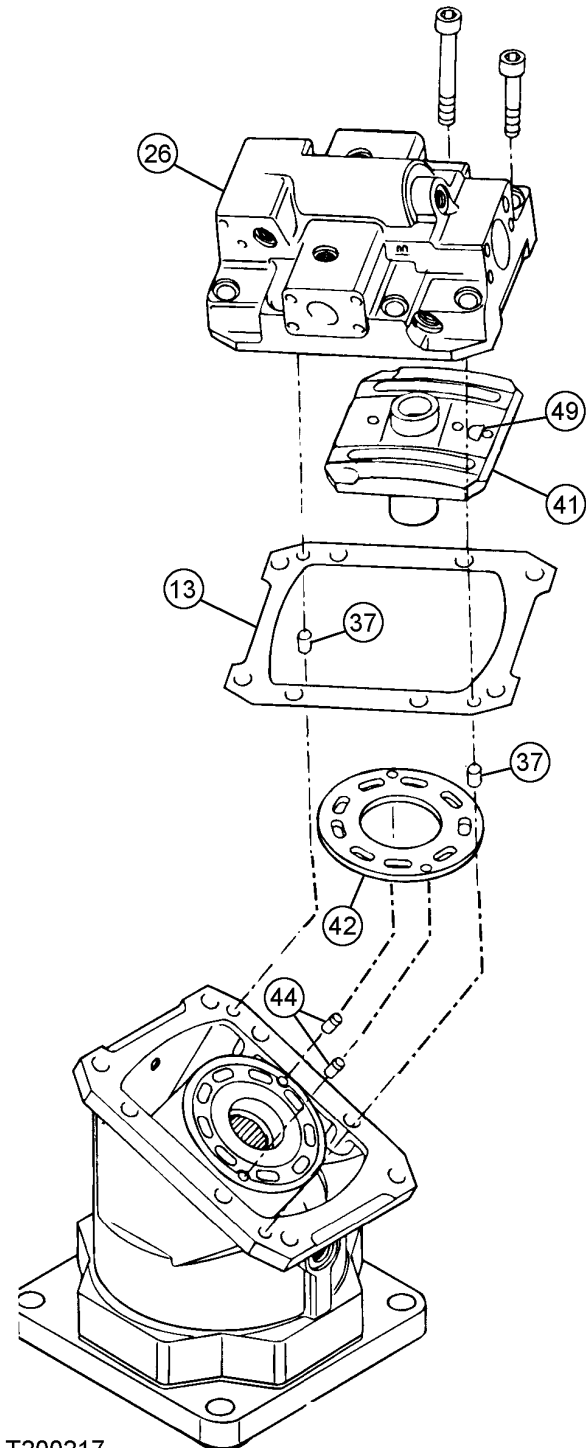

T200217

Bearing Plate

T200217 —UN—20MAY04

Continued on next page

TE14778.0000020 -19-21JUL09-12/13

36. Apply clean hydrostatic oil to valve segment and bearing plate mating surfaces. Install end cap assembly and valve segment. The spindle must engage the bearing in the cylinder block.

**IMPORTANT: DO NOT allow the pistons or synchronizer shaft rollers to fall out of position. Internal machine damage can occur.**

37. Install hex socket head cap screws (19).

*NOTE: The internal spring in the motor shaft should hold the end cap away from the housing a short distance.*

38. Tighten the screws by hand in the sequence shown (1—8) while rotating the motor shaft to ensure proper positioning of the synchronizer shaft rollers.

**IMPORTANT: DO NOT force the end cap into position on the housing. Internal machine damage can occur.**

39. Tighten screws using sequence shown to approximately 1/2 final torque value. Repeat sequence and tighten to final torque.

**Specification**

Motor End Cap-to-Housing Cap	
Screw—Torque.....	74 N·m 55 lb.-ft.

40. Rotate shaft 360° to check final assembly.

41. Install gasket (9) and solenoid valve assembly onto end cap housing with hex socket head cap screws (8).

42. Tighten screws to specification.

**Specification**

Solenoid Valve-to-End Cap Screw—Torque.....	110 N·m 81 lb.-ft.
---	-----------------------

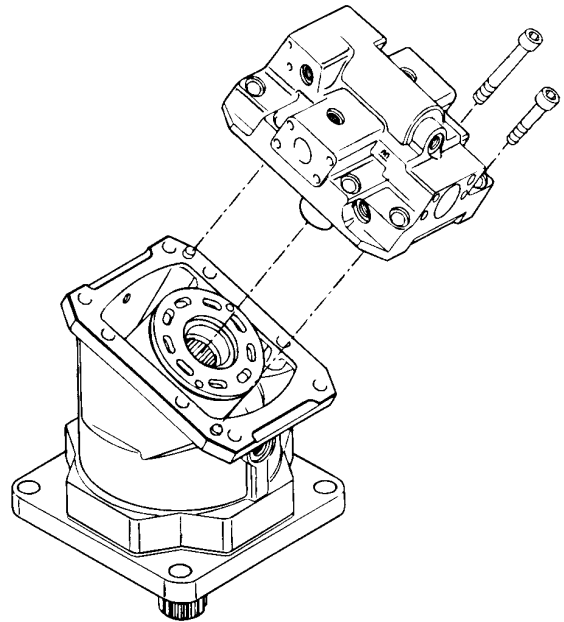

End Cap Assembly & Valve Segment

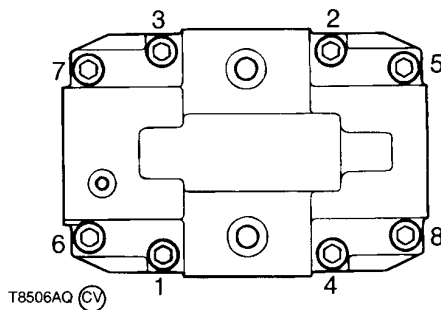

Screw Torque

T8506AP —UN—10JUL95

T8506AQ —UN—10JUL95

TE14778,0000020 -19-21JUL09-13/13

### Oil Cooler Thermal Bypass Valve Remove and Install

**NOTE:** The approximate capacity of the hydrostatic reservoir is 43 L (11.3 gal).

**NOTE:** Hoses removed for clarity.

1. Drain or apply a vacuum to hydrostatic reservoir.
2. Disconnect temperature sensor wire (3).
3. Disconnect hoses (1, 5, 6, 9, and 11).
4. Remove cap screws (8) and nuts (2).
5. Remove oil cooler thermal bypass valve (7). Replace parts as needed.
6. Install oil cooler thermal bypass valve (7) using cap screws (8) and nuts (2). Tighten cap screws to specification.

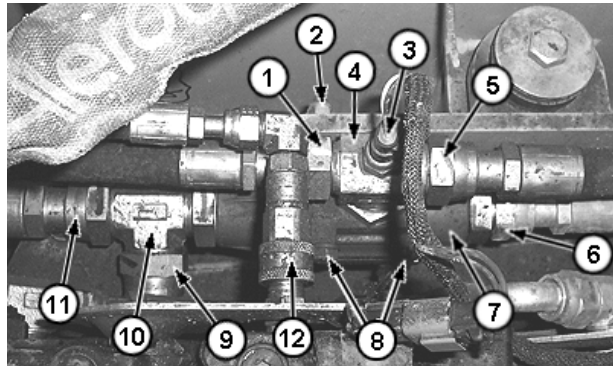

T198914A—UN—14MAY04

- |  |   |
|--|---|
| 1— Left Hydrostatic Motor Tee Fitting-to-Oil Cooler Thermal Bypass Valve | 7— Oil Cooler Thermal Bypass Valve                      |
| 2— Nut (2 used)  | 8— Cap Screws (2 used)                                  |
| 3— Temperature Sensor Wire   | 9— Oil Cooler Outlet-to-Oil Cooler Thermal Bypass Valve |
| 4— Tee Fitting   | 10— Tee Fitting   |
| 5— Oil Cooler Thermal Bypass Valve-to-Front Hydrostatic Pump Tee Fitting | 11— Oil Cooler Thermal Bypass Valve-to-Reservoir        |
| 6— Oil Cooler Thermal Bypass Valve-to-Oil Cooler Inlet                   | 12— Park Brake Quick Coupler                            |

**Specification**

Oil Cooler Thermal Bypass Valve Mounting Cap Screws—Torque.....	80 N·m 60 lb·ft
---	--------------------

7. Install hoses (1, 5, 6, 9, and 11).
8. Install temperature sensor wire (3).
9. Fill reservoir if drained. See Transmission and Hydraulic Oil. (Operators Manual.)

**Specification**

Hydrostatic Reservoir—Capacity.....	43 L Approximate 11.3 gal Approximate
-------------------------------------	--

TE14778,000003C -19-13MAY04-1/1

### Hydrostatic Filter Remove and Install

1. Loosen filler plug on reservoir to release pressure.
2. Tag and disconnect hoses (1 and 2). Cap or plug all openings.
3. Disconnect hydrostatic filter wiring lead.
4. Loosen cap screws on top of filter base and slide cap screws through slots to remove filter.
5. Install filter and tighten cap screws.

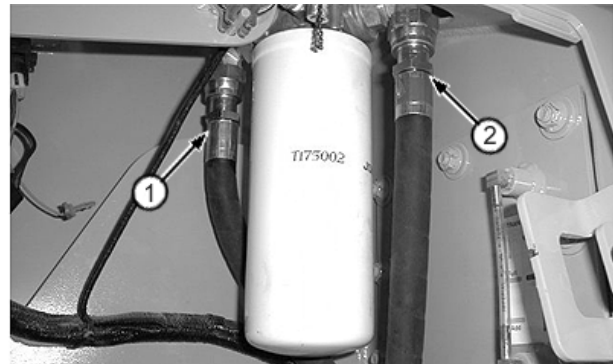

T118008B—UN—15JAN99

- |  |  |
|--|--|
| 1— Hydrostatic Filter-to-Hydrostatic Pump Hose | 2— Hydrostatic Pump-to-Hydrostatic Filter Hose |
|--|--|

**Hydrostatic Filter—Specification**

Hydrostatic Reservoir-to-Filter Base Cap Screws—Torque.....	50 N·m 37 lb·ft
---	--------------------

6. Connect hoses to filter and wiring lead.

CED.OUTX547,121 -19-14MAY04-1/1

*Hydrostatic System*

### Hydrostatic Filter Disassemble and Assemble

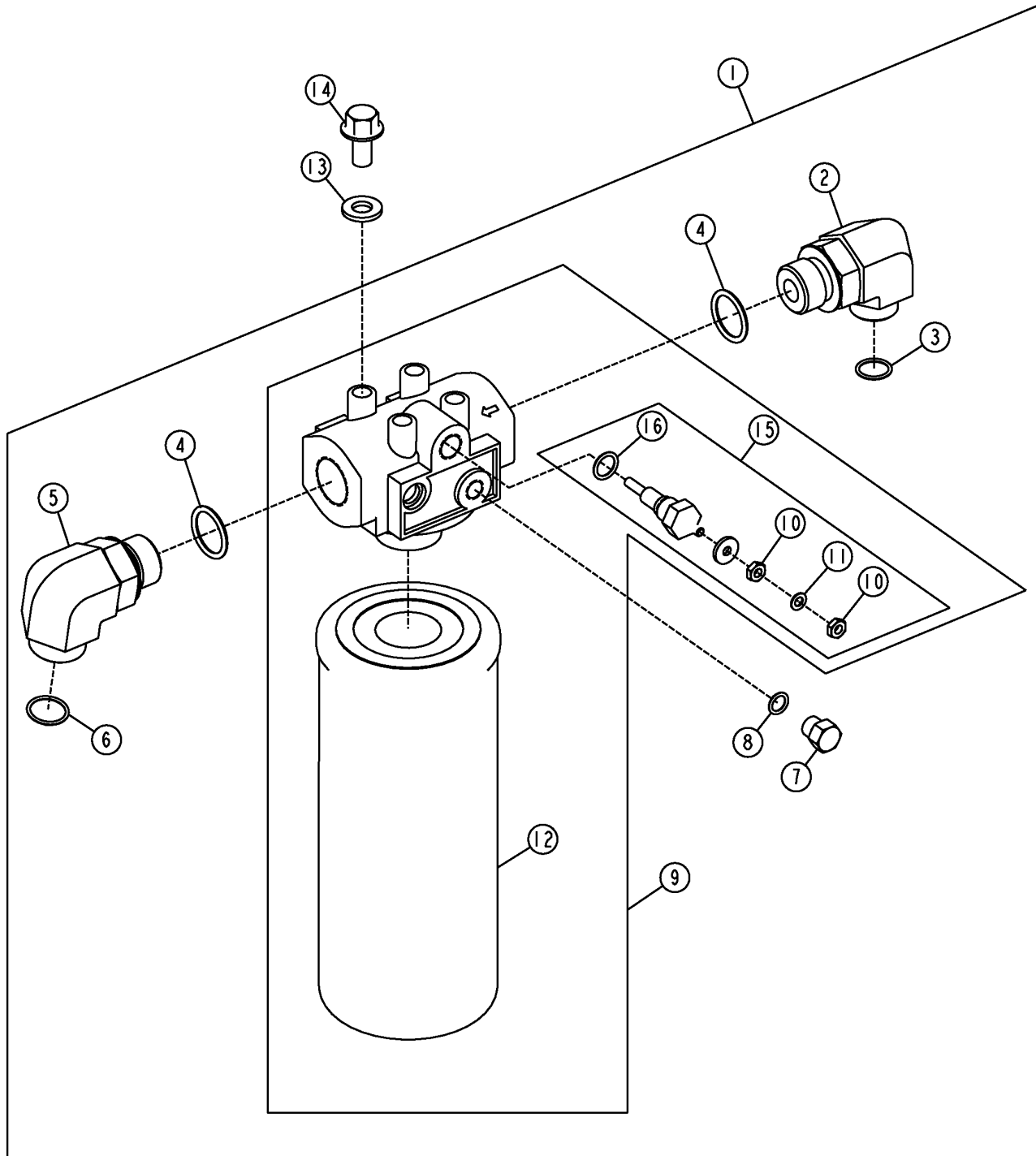

T199931

T199931 —UN—14MAY04

Continued on next page

TE14778,000003D -19-14MAY04-1/2

## Hydrostatic System

- |                                |                  |                           |                                  |
|--------------------------------|------------------|---------------------------|----------------------------------|
| 1— Hydrostatic Filter Assembly | 5— Elbow Fitting | 9— Filter Base and Filter | 13— Washer (4 used)              |
| 2— Elbow Fitting               | 6— O-Ring        | 10— Nut (2 used)          | 14— Cap Screw (4 used)           |
| 3— O-Ring                      | 7— Plug Fitting  | 11— Washer                | 15— Restriction Indicator Switch |
| 4— O-Ring (2 used)             | 8— O-Ring        | 12— Filter                | 16— O-Ring                       |

1. Disassemble parts as shown.
2. Inspect parts. Replace if necessary.
3. Tighten plug (7) to specification.
4. Tighten restriction indicator switch (15) to specification.

### Specification

Hydrostatic Filter  
 Plug—Torque..... 11 N·m  
 97 lb·in.

### Specification

Hydrostatic Filter  
 Restriction Indicator  
 Switch—Torque..... 1.4—6.8 N·m  
 12—60 lb·in.

TE14778,000003D -19-14MAY04-2/2

## Hydrostatic Reservoir Remove and Install

1. Turn battery disconnect switch to OFF.
2. Remove cab or ROPS. See Cab or ROPS Remove and Install. (Group 1800.)

*NOTE: The approximate capacity of the hydrostatic reservoir is 43 L (11.3 gal).*

3. Drain reservoir.
4. Disconnect hoses (1 and 2) from hydrostatic filter. Cap or plug all openings.
5. Disconnect wire to hydrostatic oil filter restriction switch (4).
6. Loosen flanged head cap screws (3) on filter and slide through slot to remove filter.
7. Disconnect battery cables and remove batteries.

- |  |  |
|--|--|
| 1— Hose (Hydrostatic Filter Outlet-to-Rear Charge Pressure Manifold Inlet Tee Fitting) | 3— Hydrostatic Reservoir-to-Oil Filter Flanged Head Cap Screw (4 used) |
| 2— Hose (Hydrostatic Filter Inlet-to-Rear Charge Pressure Manifold Outlet Tee Fitting) | 4— Oil Filter Restriction Switch                                       |

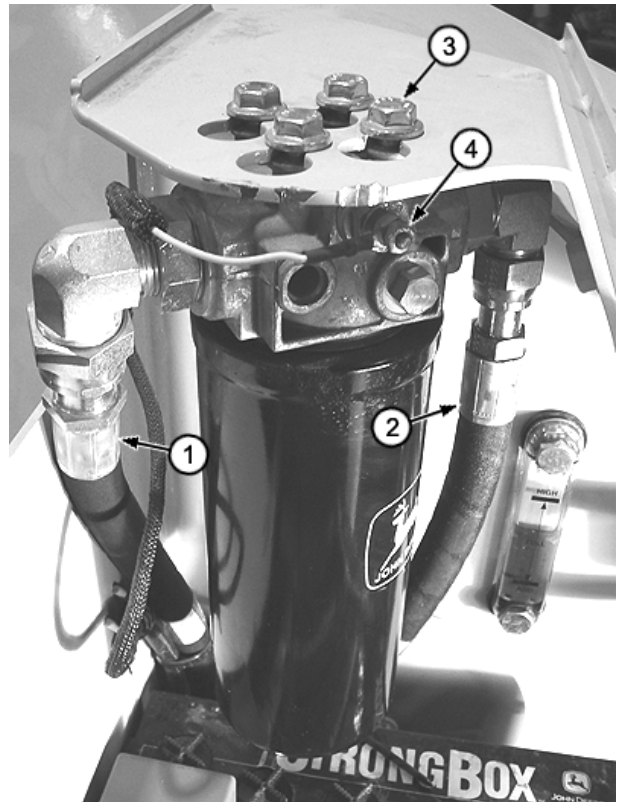

T200315A —UN—27MAY04

Continued on next page

TE14778,0000042 -19-26MAY04-1/3

## Hydrostatic System

8. Disconnect hoses (5—7). Cap or plug all openings.
9. Remove necessary tie bands and route oil filter restriction switch harness and hoses through reservoir frame.

**⚠ CAUTION: The approximate weight of hydrostatic reservoir is 96 kg (212 lb).**

### Hydrostatic Reservoir—Specification

Reservoir—Weight..... 96 kg Approximate  
212 lb Approximate

10. Install chain and hoist.

5—Hose (Park Brake  
Outlet-to-Hydrostatic  
Reservoir)  
6—Hose (Oil Cooler Bypass  
Valve-to-Hydrostatic  
Reservoir)

7—Hose (Hydrostatic  
Reservoir-to-Charge Pump)

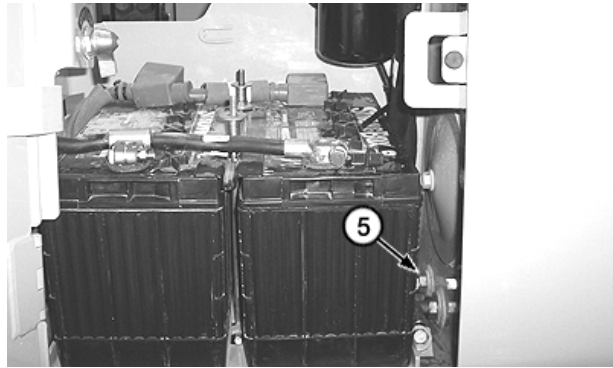

T200324A —UN—27MAY04

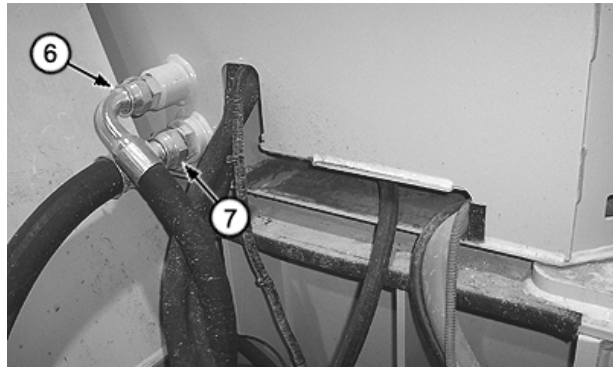

T200325A —UN—27MAY04

Continued on next page

TE14778,0000042 -19-26MAY04-2/3

## Hydrostatic System

11. Loosen rear bracket to fuel tank cap screw and remove cap screws (8—10).
12. Remove reservoir.
13. Install reservoir using cap screws (8—10). Tighten cap screws to specification.

### Hydrostatic Reservoir—Specification

Main Frame-to-Reservoir Front Cap	
Screws—Torque.....	319 N·m 235 lb-ft
Main Frame-to-Reservoir Rear Cap	
Screws—Torque.....	310 N·m 235 lb-ft
Fuel Tank Bracket-to-Hydrostatic Reservoir—Torque.....	
	244 N·m 180 lb-ft
Brackets-to-Isolators-to-Fuel Tank Cap	
Screws—Torque.....	87 N·m 64 lb-ft

14. Route filter hoses and oil filter restriction switch harness through reservoir frame. Connect harness to oil filter restriction switch. Tighten hex nut to specification.

### Specification

—Torque.....	0.56—0.79 N·m 5—7 lb-in.
--------------	-----------------------------

15. Install filter and tighten cap screws.

### Hydrostatic Filter—Specification

Hydrostatic Reservoir-to-Filter Base Cap	
Screws—Torque.....	50 N·m 37 lb-ft

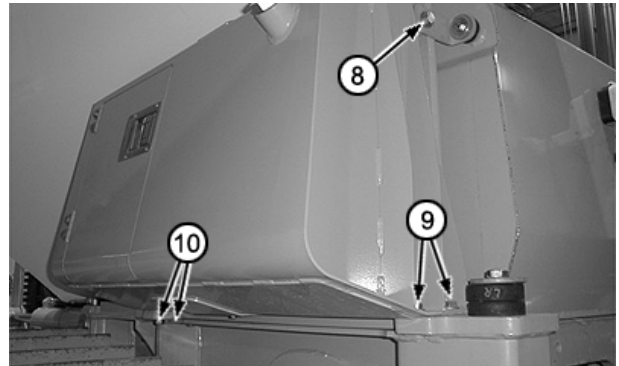

T200334A —UN—26MAY04

- |  |  |
|--|--|
| <p><b>8— Bracket-to-Hydrostatic Reservoir Cap Screw</b><br/> <b>9— Hydrostatic Reservoir-to-Main Frame Rear Cap Screw (2 used)</b></p> | <p><b>10— Hydrostatic Reservoir-to-Main Frame Front Cap Screw (2 used)</b></p> |
|--|--|

16. Connect hydrostatic filter hoses.
17. Replace all tie bands that were removed.
18. Install batteries and connect cables.
19. Install cab/ROPS. See Cab or ROPS Remove and Install. (Group 1800.)
20. Fill reservoir. See Transmission and Hydraulic Oil. (Operators Manual.)

### Specification

Hydrostatic Reservoir—Capacity.....	
	43 L Approximate 11.3 gal Approximate

21. Turn battery disconnect switch to ON.

TE14778,0000042 -19-26MAY04-3/3

*Hydrostatic System*

**Section 04  
Engine**

**Contents**

Page

**Group 0400—Removal and Installation**  
Engine  
Remove and Install .....04-0400-1

*Contents*

## Engine Remove and Install

**⚠ CAUTION:** Explosive release of fluids from pressurized cooling system can cause serious burns.

Shut off engine. Only remove filler cap when cool enough to touch with bare hands. Slowly loosen cap to first stop to relieve pressure before removing completely.

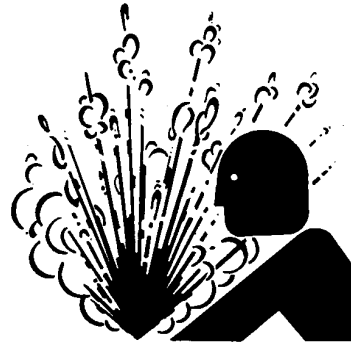

1. Drain engine coolant. See Miscellaneous—Specifications. (Operator's Manual)
2. Remove engine side shields.
3. Remove hood. See Hood Remove and Install. (Group 1910.)
4. Turn battery disconnect switch to OFF.
5. Remove fan blade and shroud. See Fan Blade and Shroud Remove and Install (450J, 550J) or Remove

and Install Fan blade and Shroud (650J). (Group 0510.)

TE14778,000000A -19-12AUG03-1/11

TS281—UN—23AUG88

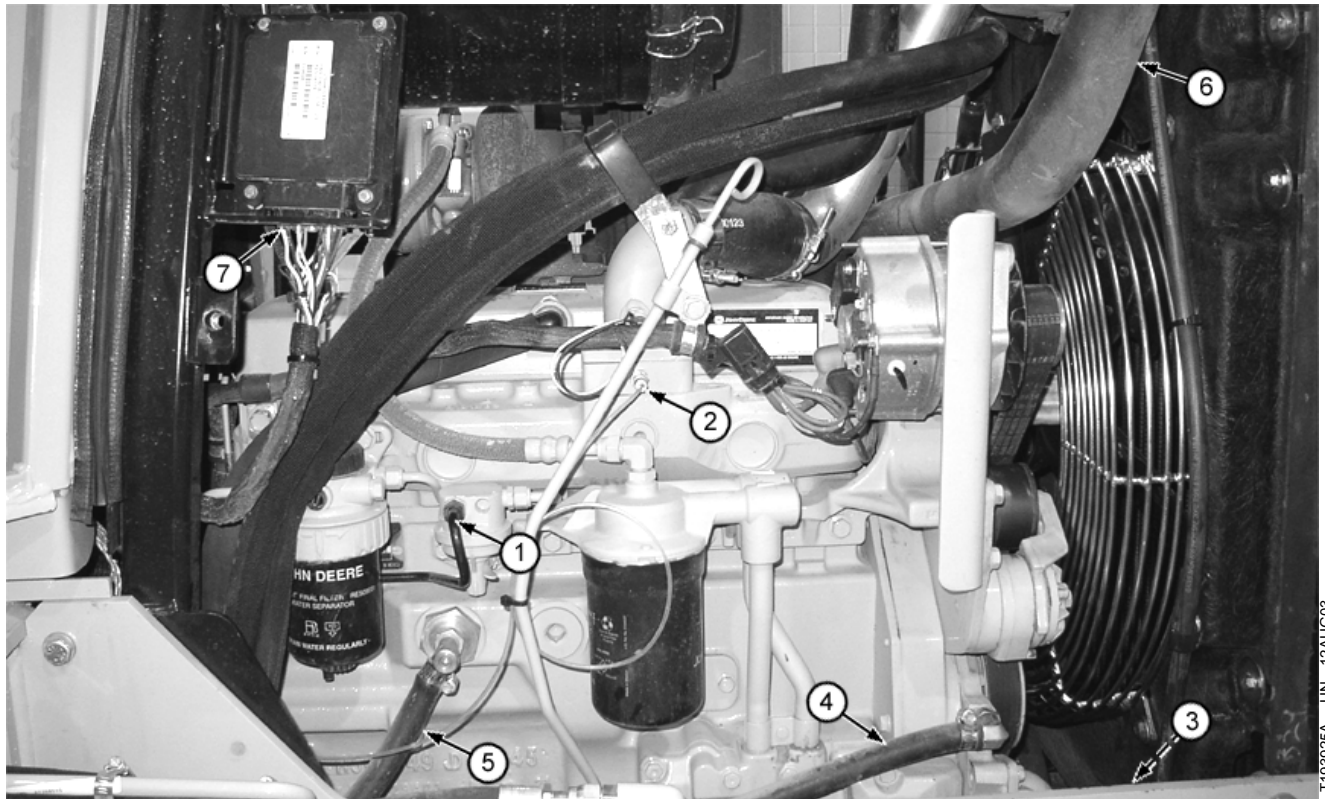

1—Fuel Supply Line  
2—Start Aid Line

3—Lower Radiator Hose  
4—Return Heater Hose

5—Supply Heater Hose  
6—Upper Radiator Hose

7—Engine Control Unit (ECU)  
Connector

6. Disconnect components (1—7).

Continued on next page

TE14778,000000A -19-12AUG03-2/11

T193925A—UN—12AUG03

Removal and Installation

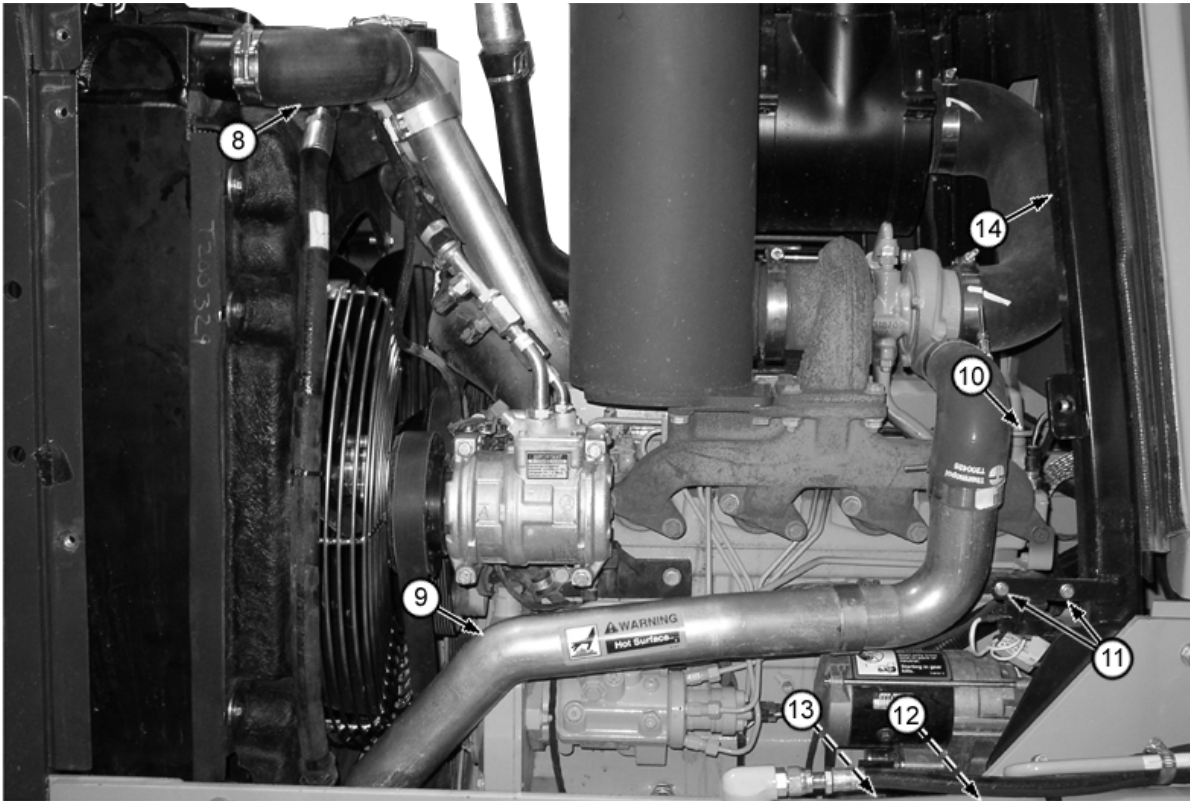

T193926A—UN—12AUG03

- |                                 |                                    |   |  |
|---------------------------------|------------------------------------|---|--|
| 8— Upper Charge Air Cooler Hose | 10— Fuel Return Line               | 12— Ground Strap and Starter Ground Cable | 14— Rear Hood Bracket with Air Cleaner |
| 9— Lower Charge Air Cooler Hose | 11— Start Relay Cap Screw (2 used) | 13— Start Solenoid Positive Cable         |  |

7. Disconnect components (8—14).
8. Remove muffler. See Muffler Without Turbocharger Remove and Install or Muffler With Turbocharger Remove and Install. (Group 0530.)
9. Remove rear support with air cleaner housing, hose, and Engine Control Unit (ECU).
10. If equipped, remove air conditioning compressor and set aside.

TE14778,000000A -19-12AUG03-3/11

11. Remove floor plate and disconnect cooler bypass hoses (13) from tee at pump case drain port.
12. Disconnect engine harness connector and red bulkhead connector (12).
13. Remove cap screws (12 used) from pump flywheel cover to engine.
14. Disconnect tee fitting (14) at pump case drain port.

- |   |                 |
|---|-----------------|
| 12— Engine Harness Connector and Red Bulkhead Connector | 14— Tee Fitting |
| 13— Cooler Bypass Hose (2 used)                         |                 |

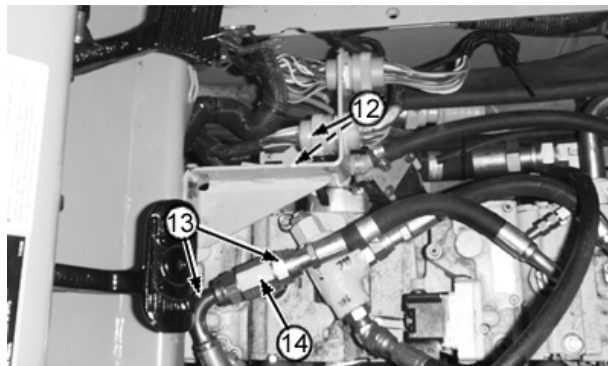

T117450B—UN—07OCT98

Continued on next page

TE14778,000000A -19-12AUG03-4/11

## Removal and Installation

15. Drill and tap a 1-1/16 in. plug to accommodate a 1/2 in. shouldered lift eyebolt. Install plug and eyebolt in pump case drain port. Trim end of eyebolt so it is even with end of plug.
16. Support hydrostatic pumps using JT07184 Pump Support Bracket or a DFT1119 <sup>1</sup>Pump Support and a small winch hoist.

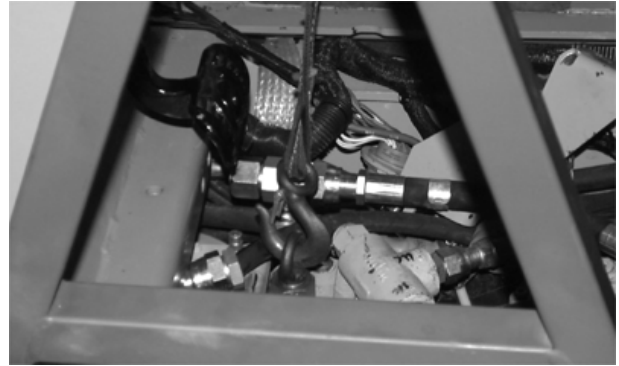

T117452B —UN—29SEP98



T117451B —UN—29SEP98

<sup>1</sup>Dealer Fabricated Tool. See Group 0999 for instructions to make tool.

Continued on next page

TE14778,000000A -19-12AUG03-5/11

**⚠ CAUTION: Prevent possible crushing injury from removing engine. Use proper lifting equipment and safety precautions.**

**Specification**

Engine—Weight..... 500 kg  
1102 lb

17. Attach JDG23 Lifting Sling and a hoist to engine.



T117453B—UN—01OCT98

TE14778,000000A -19-12AUG03-6/11

18. Loosen guide cap screw in slotted groove (15). This is used to guide the engine out and back in.

19. Remove front and rear side rail to engine cap screws.

20. Lift engine forward and up between frame rails.

21. Remove wiring if necessary. See Engine Harness (W6) Component Location. (Group 9015-10.)

**15— Guide Cap Screw in Slotted Groove**

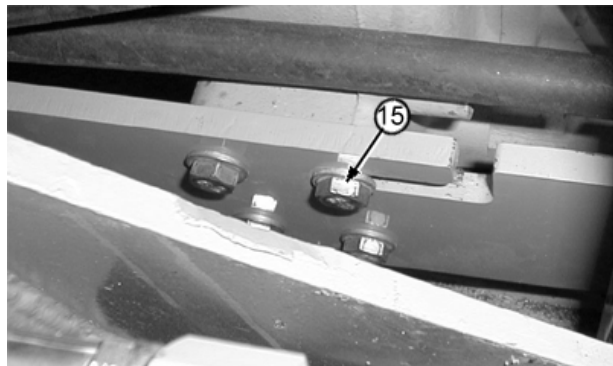

T117472B—UN—01OCT98

Continued on next page

TE14778,000000A -19-12AUG03-7/11

Removal and Installation

22. If equipped with hydraulic pump with drive through shaft the flywheel will have a flywheel ring (3), cap screws (1), and washers (2).

Apply thread lock and sealer (medium strength) to threads of cap screws (1). Tighten cap screws (1) to specification.

**Engine—Specification**

Pump Flywheel	
Ring-to-Flywheel	
Housing Cap	
Screws—Torque.....	57 N·m
	42 lb·ft

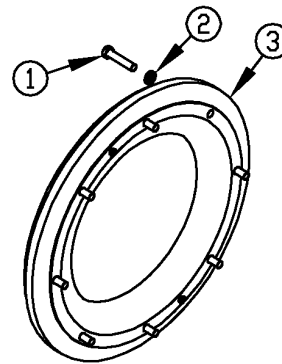

T128308

- 1— Cap Screw (8 used)  
2— Washer (8 used)

- 3— Flywheel Ring

**Engine —Specification**

Pump Flywheel	
Cover-to-Flywheel	
Housing Cap	
Screws—Torque.....	73 N·m
	54 lb·ft

23. Install engine using side rail cap screws to guide engine in through slots aligning pump drive.
24. Install pump flywheel housing cap screws before removing pump support.
25. Remove pump support.
26. Install the remaining flywheel housing cap screws. Tighten cap screws to specification.

TE14778,000000A -19-12AUG03-8/11

T128308 —UN—15FEB00

27. Install tee fitting (14). Connect cooler bypass hoses (13), engine harness connector and (red) bulkhead connector (12).

- 12— Engine Harness Connector and (Red) Bulkhead Connector  
13— Cooler Bypass Hose (2 used)  
14— Tee Fitting

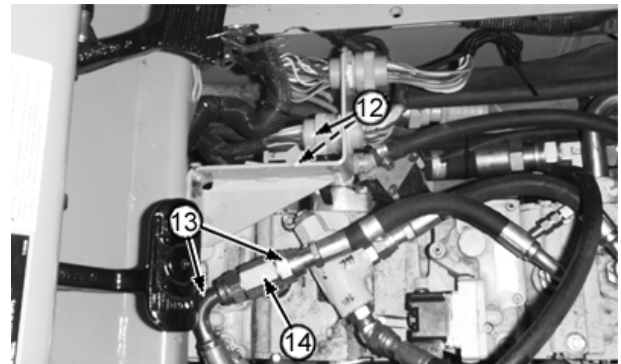

Continued on next page

TE14778,000000A -19-12AUG03-9/11

T117450B —UN—07OCT98

Removal and Installation

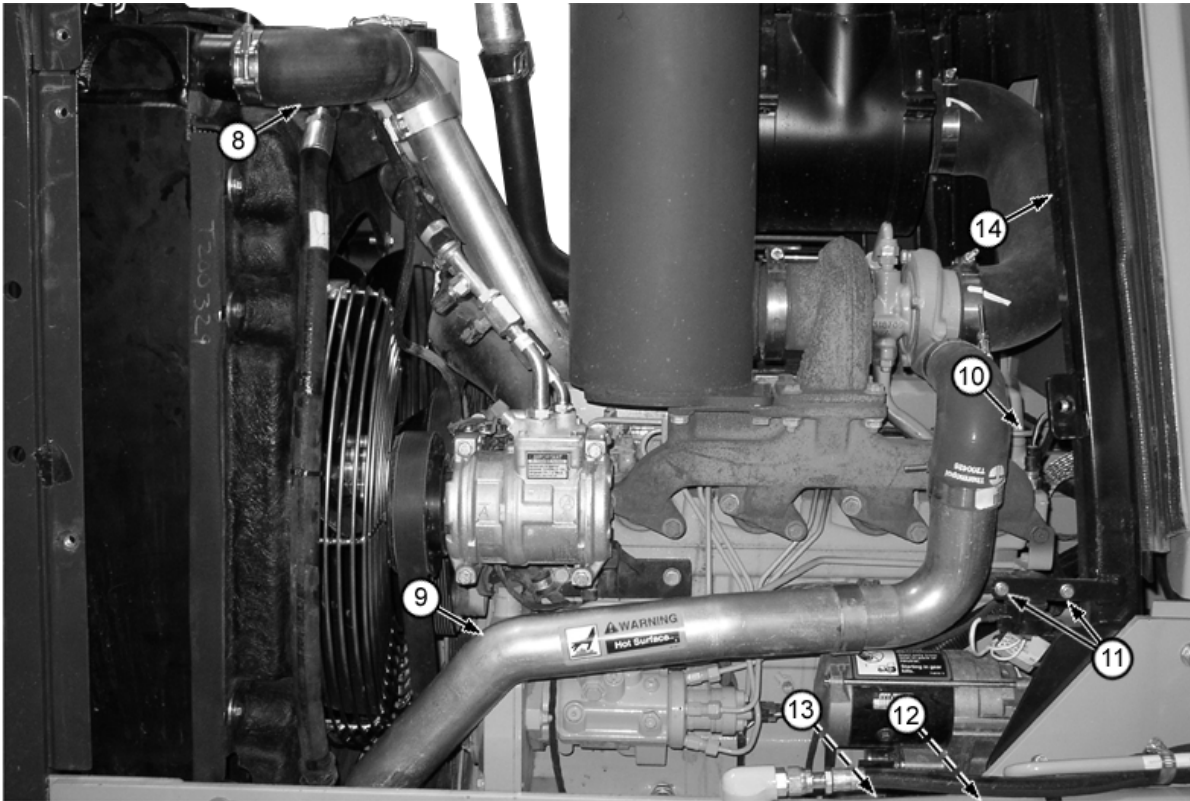

T193926A —UN—12AUG03

- |                                    |                                       |  |   |
|------------------------------------|---------------------------------------|--|---|
| 8— Upper Charge Air Cooler<br>Hose | 10— Fuel Return Line                  | 12— Ground Strap and Starter<br>Ground Cable | 14— Rear Hood Bracket with Air<br>Cleaner |
| 9— Lower Charge Air Cooler<br>Hose | 11— Start Relay Cap Screw (2<br>used) | 13— Start Solenoid Positive<br>Cable         |   |

28. Install components (8—14).

Continued on next page

TE14778,000000A -19-12AUG03-10/11

Removal and Installation

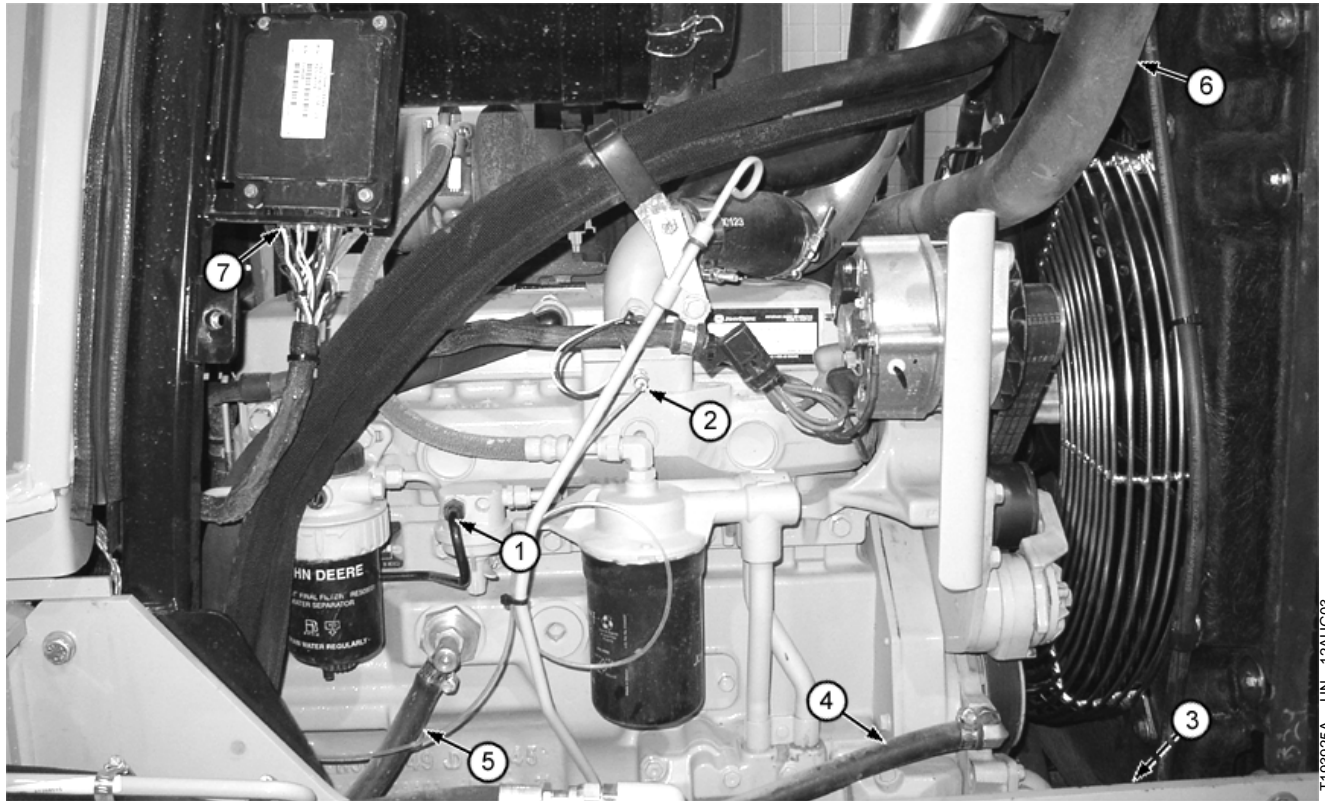

T193925A—UN—12AUG03

1— Fuel Supply Line  
2— Start Aid Line

3— Lower Radiator Hose  
4— Return Heater Hose

5— Supply Heater Hose  
6— Upper Radiator Hose

7— Engine Control Unit (ECU)  
Connector

29. Install and connect components (1—7).

30. Install fan blade and shroud. See Fan Blade and Shroud Remove and Install (450J, 550J) or Fan Blade and Shroud Remove and Install (650J). (Group 0510.)

31. Install floor plate and bottom guard plate.

32. Turn battery disconnect switch to ON.

33. Install hood and side shields. See Hood Support and Engine Side Shields Remove and Install. (Group 1910.)

34. Fill radiator with coolant.

**Specification**

Engine Coolant—Capacity.....	11 L
	3 gal

35. Bleed fuel system. See Bleed the Fuel System. (CTM331.)

TE14778,000000A -19-12AUG03-11/11



## Section 05 Engine Auxiliary Systems

### Contents

	Page
<b>Group 0505—Cold Weather Starting Aids</b>	
Engine Coolant Heater	
Remove and Install .....	05-0505-1
Starting Aid	
Remove and Install .....	05-0505-2
Starting Aid Solenoid	
Remove and Install .....	05-0505-3
<b>Group 0510—Radiator and Fan Shroud</b>	
Fan Blade and Shroud Remove	
and Install (450J, 550J) .....	05-0510-1
Fan Blade and Shroud Remove	
and Install (650J) .....	05-0510-2
Cooling Package Remove and	
Install (450J, 550J) .....	05-0510-3
Cooling Package Remove and	
Install (650J) .....	05-0510-4
Sand Shield Remove and Install .....	05-0510-7
<b>Group 0515—Engine Speed Control</b>	
Decelerator/Brake Pedal Remove	
and Install .....	05-0515-1
Decelerator/Brake Pedal	
Disassemble and Assemble .....	05-0515-2
<b>Group 0520—Intake System</b>	
Air Cleaner Remove and Install	
550J and 650J .....	05-0520-1
<b>Group 0530—External Exhaust System</b>	
Muffler Without Turbocharger	
Remove and Install .....	05-0530-1
Muffler With Turbocharger Remove	
and Install .....	05-0530-2
<b>Group 0540—Mounting Frame</b>	
Engine and Power Train	
Mounting .....	05-0540-1
<b>Group 0560—External Fuel Supply System</b>	
Fuel Tank Remove and Install .....	05-0560-1

*Contents*

**Engine Coolant Heater Remove and Install**

**⚠ CAUTION: TEST COOLANT HEATER ONLY WHEN HEATING ELEMENT IS IMMERSSED IN LIQUID. Prevent possible injury from explosion. Do not plug coolant heater into electrical power unless heating element is immersed in liquid. Sheath could burst and result in injury.**

Use a heavy-duty grounded cord to connect coolant heater to electrical power.

**⚠ CAUTION: Explosive release of fluids from pressurized cooling system can cause serious burns.**

**Shut off engine. Only remove filler cap when cool enough to touch with bare hands. Slowly loosen cap to first stop to relieve pressure before removing completely.**

1. Drain coolant from radiator and engine block.

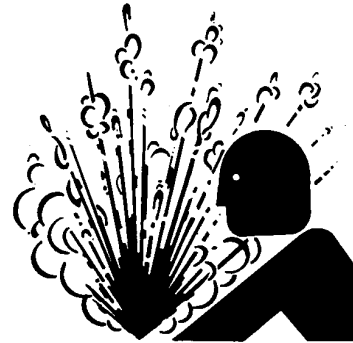

TS281—UN—23AUG88

**Specification**

Engine Coolant—Capacity..... 11 L  
3 gal

2. Remove right side engine shield.

CED,TX03399,5015 -19-09MAR04-1/3

3. Disconnect cord from heater. Loosen nut (2). Remove adapter (1) to remove heater element from cylinder block.

1— Adapter

2— Nut

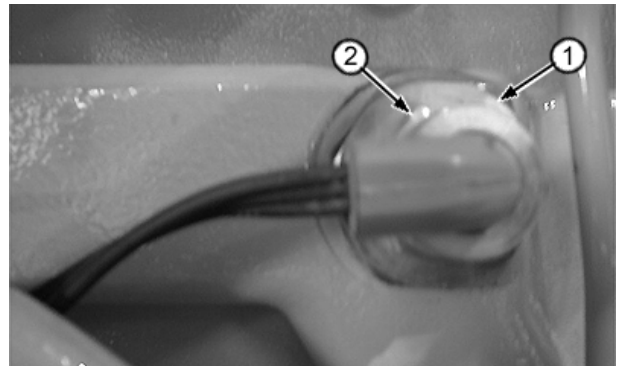

T117492B—UN—01OCT98

Continued on next page

CED,TX03399,5015 -19-09MAR04-2/3

## Cold Weather Starting Aids

4. Install gasket (A) on heater element and O-ring (B) on adapter (C). Install heater element through adapter (C) and install nut (D), but do not tighten.
5. Install heater into cylinder block with element pointing towards the flywheel.
6. Tighten adapter (C).
7. Turn element clockwise and then counterclockwise until element contacts casting. Move element midway between contact points.
8. Hold element with a wrench and tighten lock nut (D) to specification.

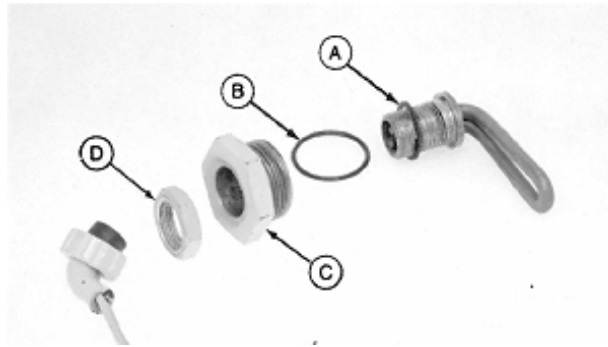

A—Gasket  
B—O-Ring  
C—Adapter  
D—Nut

T87072—JUN—21OCT88

### Specification

Engine Coolant Heater	
Element Nut—Torque.....	.34 N·m 25 lb·ft

9. Connect cord to heater. Install engine side shield.
10. Fill radiator and engine block with coolant.

### Specification

Engine Coolant—Capac-	
ity.....	11 L 3 gal

CED, TX03399, 5015 -19-09MAR04-3/3

## Start Aid Remove and Install

1. Remove right engine side shield
  2. Disconnect starting aid tube (1).
- NOTE: Mark location of red dot when removing.*
3. Remove nozzle holder from air inlet.
  4. Clean or replace nozzle holder as required.

*NOTE: Red dot (2) on nozzle holder must be installed at the 12 o'clock position, facing the incoming air flow. Nozzle orifice (3) needs to be in the path of the air flow to disperse fluid for quick start of engine.*

5. Install nozzle and connect starting aid tube.
6. Install engine side shield

1— Starting Aid Tube  
2— Red Dot for Nozzle Installation  
3— Orifice

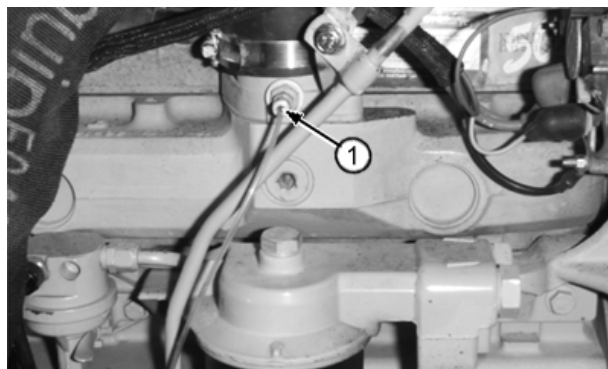

Starting Aid Tube

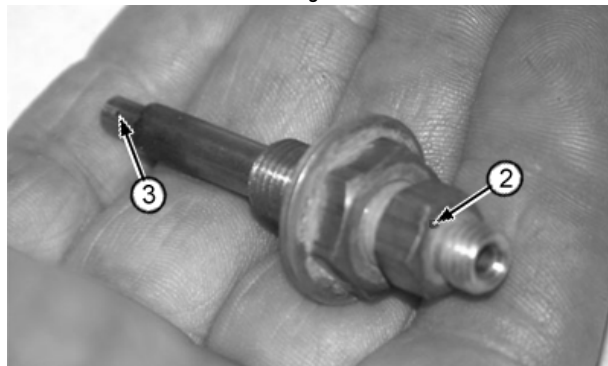

Nozzle Holder

T117494B—JUN—01OCT98

T117496B—JUN—13OCT98

KV70328, 0000077 -19-14JUN06-1/1

### Starting Aid Solenoid Remove and Install

1. Open right side access door.
2. Remove starting fluid can (1).
3. Disconnect wiring lead connector (4) and starting aid tube (3).
4. Remove bracket and solenoid (2).
5. Install solenoid and bracket.
6. Connect starting aid tube and wiring lead connector (4).

1— Solenoid Fluid Can  
2— Bracket and Solenoid

3— Starting Aid Tube  
4— Wiring Lead Connector

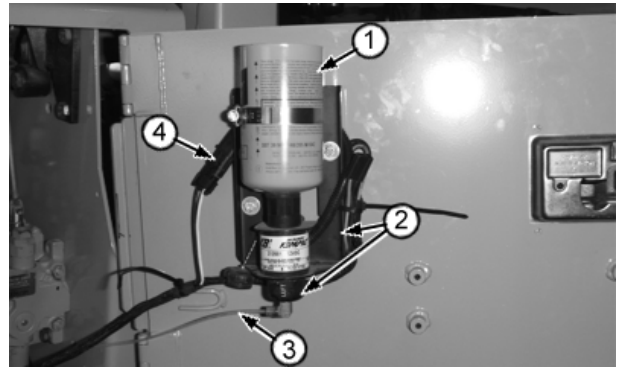

Starting Aid Solenoid

T117493B —UN—01OCT98

KV70328,0000078 -19-14JUN06-1/1

*Cold Weather Starting Aids*

**Fan Blade and Shroud Remove and Install (450J, 550J)**

1. Remove engine side shields from both sides of machine.
2. Release belt tension adjuster to loosen belt.
3. Disconnect air conditioning compressor wiring harness (4).
4. Remove cap screws (5) and set compressor aside.
5. Remove fan guard (3).
6. Remove fan blade, spacer, and pulley.
7. Remove hood. See Hood Remove and Install. (Group 1910.)
8. Remove fan shroud.
9. Disconnect upper oil cooler hose (1), radiator hose (2), and coolant over flow tube from coolant reservoir (5).
10. Remove cap screws and rotate fan shroud 90° upward.
11. Install fan shroud (4).
12. Connect upper cooler hose (1), radiator hose (2), and coolant over flow tube.

*NOTE: Use two M10 x 50 mm cap screws to draw in spacer and pulley to fan drive hub to aid in assembly.*

13. Install fan pulley, spacer and fan. Tighten fan cap screws to specification.

**Specification**

Fan Blade Cap	
Screws—Torque.....	73 N·m 54 lb-ft

14. Install fan guard. Tighten cap screws to specification.

**Specification**

Fan Guard Cap	
Screws—Torque.....	16—19 N·m 142—168 lb-in.

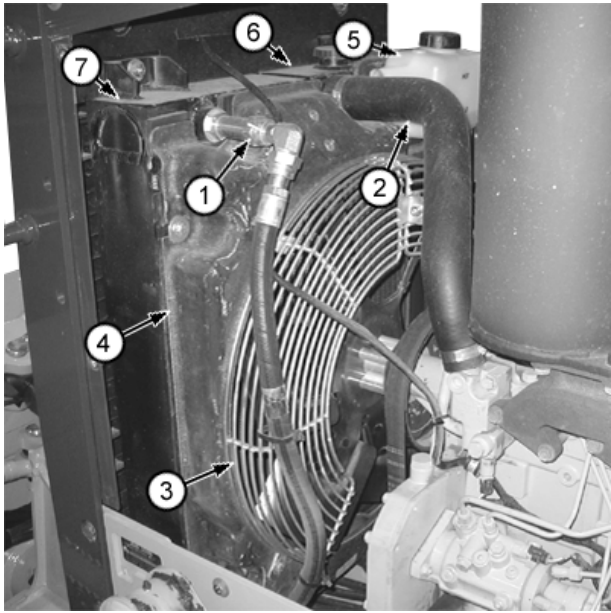

T197451A —UN—23JAN04

- |                          |                                |
|--------------------------|--------------------------------|
| 1— Upper Oil Cooler Hose | 5— Radiator Overflow Reservoir |
| 2— Radiator Hose         | 6— Radiator                    |
| 3— Fan Guard             | 7— Oil Cooler                  |
| 4— Fan Shroud            |                                |

15. Install compressor. Tighten cap screws to specification.

**Specification**

Compressor Cap	
Screws—Torque.....	35 N·m 26 lb-ft

16. Connect air conditioning compressor wiring harness.
17. Install fan belt and engine side shields.
18. Install hood. See Hood Remove and Install. (Group 1910.)

DW09104,00000D6 -19-23JAN04-1/1

### Fan Blade and Shroud Remove and Install (650J)

1. Remove engine side shields. Remove hood. See Hood Remove and Install. (Group 1910.)
2. Release belt tension adjuster to loosen belt.
3. Remove fan guard cap screws (9). Remove fan guards.
4. Remove fan blade, spacer, and pulley.
5. Remove engine oil fill hose bracket (4).
6. Drain engine coolant.

**Specification**

Engine Coolant—Capacity approximate..... 13.25 L  
3.5 gal

7. Remove hoses (2, 3, 6, and 7). Cap and plug all openings
8. Disconnect wiring harness (1) from horn and lights. Move wiring harness aside.
9. Remove grille. See Grille and Grille Housing Removal. (Group 1921.)
10. Remove shroud cap screws (8). Remove shroud. Repair or replace as necessary.

*NOTE: If replacing shroud, coolant overflow bottle must be installed on new shroud*

11. Install shroud cap screws (8).
12. Connect wiring harness (1) to horn and lights.
13. Install hoses (2, 3, 6, and 7).
14. Fill engine coolant.

**Specification**

Engine Coolant—Capacity approximate..... 13.25 L  
3.5 gal

15. Install engine oil fill hose bracket (4).
- NOTE: To aid in assembly, use two M10 x 50 mm cap screws to draw in spacer and pulley to fan drive hub.*
16. Install fan pulley, spacer and fan. Tighten fan cap screws to specification.

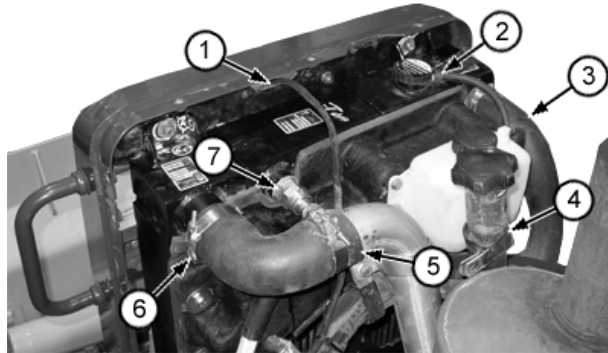

Remove Hoses

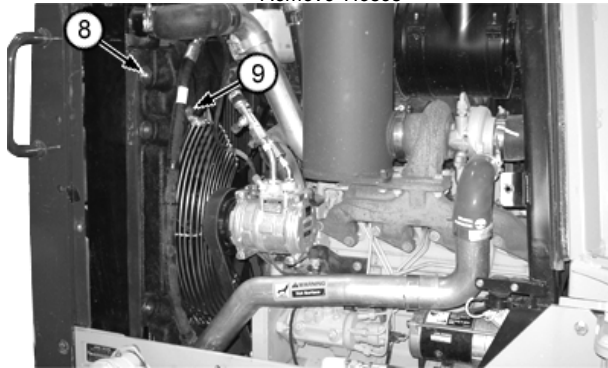

- |                            |                            |
|----------------------------|----------------------------|
| 1— Wiring Harness          | 6— Charge Air Hose         |
| 2— Radiator Overflow Hose  | 7— Hydrostatic Cooler Line |
| 3— Radiator Hose           | 8— Fan Shroud Cap Screw    |
| 4— Oil Fill Hose Bracket   | 9— Fan Guard Cap Screw     |
| 5— Charge Air Hose Bracket |                            |

**Specification**

Fan Blade Cap  
Screws—Torque.....73 N·m  
54 lb·ft

17. Install fan guard. Tighten cap screws to specification.

**Specification**

Fan Guard Cap  
Screws—Torque..... 16—19 N·m  
142—168 lb·in.

18. Install belt.
19. Install engine side shields Install hood. See Hood Remove and Install. (Group 1910.)

DW09104,00000D7 -19-23JAN04-1/1

T193954A —UN—12AUG03

T193957A —UN—12AUG03

### Cooling Package Remove and Install (450J, 550J)

**CAUTION:** Explosive release of fluids from pressurized cooling system can cause serious burns.

Shut off engine. Only remove filler cap when cool enough to touch with bare hands. Slowly loosen cap to first stop to relieve pressure before removing completely.

1. Remove grille and grille housing. See Grille and Grille Housing Removal. (Group 1921.)
2. Drain engine coolant. See 450J-LT and 450J-LGP Crawler Dozer Drain and Refill Capacities or See 550J-LT and 550J-LGP Crawler Dozer Drain and Refill Capacities. (Operator's Manual.)
3. Apply vacuum to hydrostatic reservoir.
4. Remove oil cooler hose (1). Cap and plug all openings.
5. Remove upper (2) and lower radiator hoses. Cap and plug all openings.
6. Remove fan guard (3).

**CAUTION:** Prevent possible injury from crushing. Heavy component, use appropriate lifting device.

7. Remove two bottom cap screws from cooling package and secure with appropriate lifting device.

**Specification**

Cooling Package—Weight—approximate.....	57 kg 125 lb
---	-----------------

8. Raise cooling package slightly and remove rubber mounts from bottom of radiator to clear frame. Remove cooling package and shroud as assembly.
9. Remove radiator shroud and overflow reservoir if replacing entire cooling package.
10. Install cooling package and shroud (4).
11. Install lower rubber mounts and tighten cap screws to specification.

**Specification**

Lower Mounting Cap Screws—Torque.....	33 N·m 25 lb-ft
---------------------------------------	--------------------

12. If removed cooling package mounting hardware.

**Specification**

Bracket-to-Radiator Cap Screws—Torque.....	73 N·m 54 lb-ft
--	--------------------

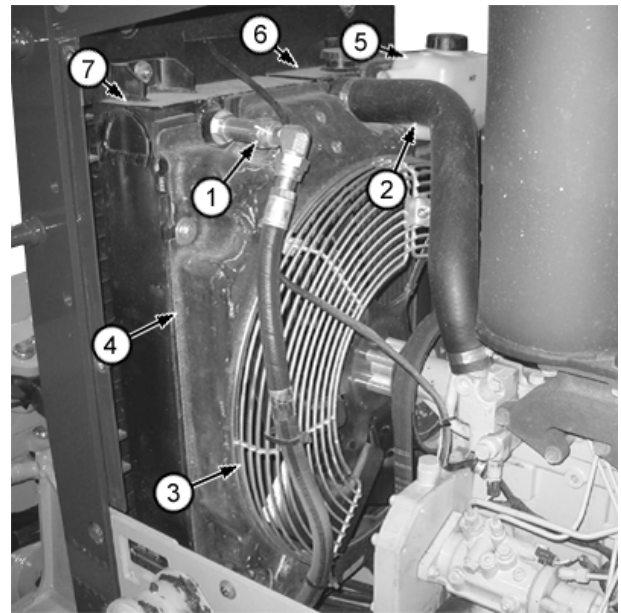

T197451A —UN—23JAN04

- |  |                               |
|--|-------------------------------|
| 1— Oil Cooler Hoses (upper hose shown) | 5— Coolant Overflow Reservoir |
| 2— Upper Radiator Hose                 | 6— Radiator                   |
| 3— Fan Guard                           | 7— Oil Cooler                 |
| 4— Fan Shroud                          |                               |

Bracket-to-Oil Cooler Cap Screws—Torque.....	73 N·m 54 lb-ft
--	--------------------

13. Install grille housing. See Grille and Grille Housing Installation. (Group 1921.)
14. Install cooling package bracket-to-grille housing. Tighten to specification.

**Specification**

Upper Cooling Package Bracket-to-Grille Housing Cap Screw—Torque.....	58 N·m 43 lb-ft
---	--------------------

15. Install fan guard (3). Tighten cap screws to specification.

**Specification**

Fan Guard Cap Screws—Torque.....	16—19 N·m 141—168 lb-in.
----------------------------------	-----------------------------

16. Install upper (2) and lower radiator hoses.

17. Connect oil cooler hoses (1) and fill radiator with coolant. See 450J-LT and 450J-LGP Crawler Dozer Drain and Refill Capacities or See 550J-LT and 550J-LGP Crawler Dozer Drain and Refill Capacities. (Operator's Manual.)

DW09104,00000D9 -19-16DEC09-1/1

## Cooling Package Remove and Install (650J)

**⚠ CAUTION:** Explosive release of fluids from pressurized cooling system can cause serious burns.

Shut off engine. Only remove filler cap when cool enough to touch with bare hands. Slowly loosen cap to first stop to relieve pressure before removing completely.



TS281—UN—23AUG88

Continued on next page

DW09104,00000DA -19-26JAN04-1/4

Radiator and Fan Shroud

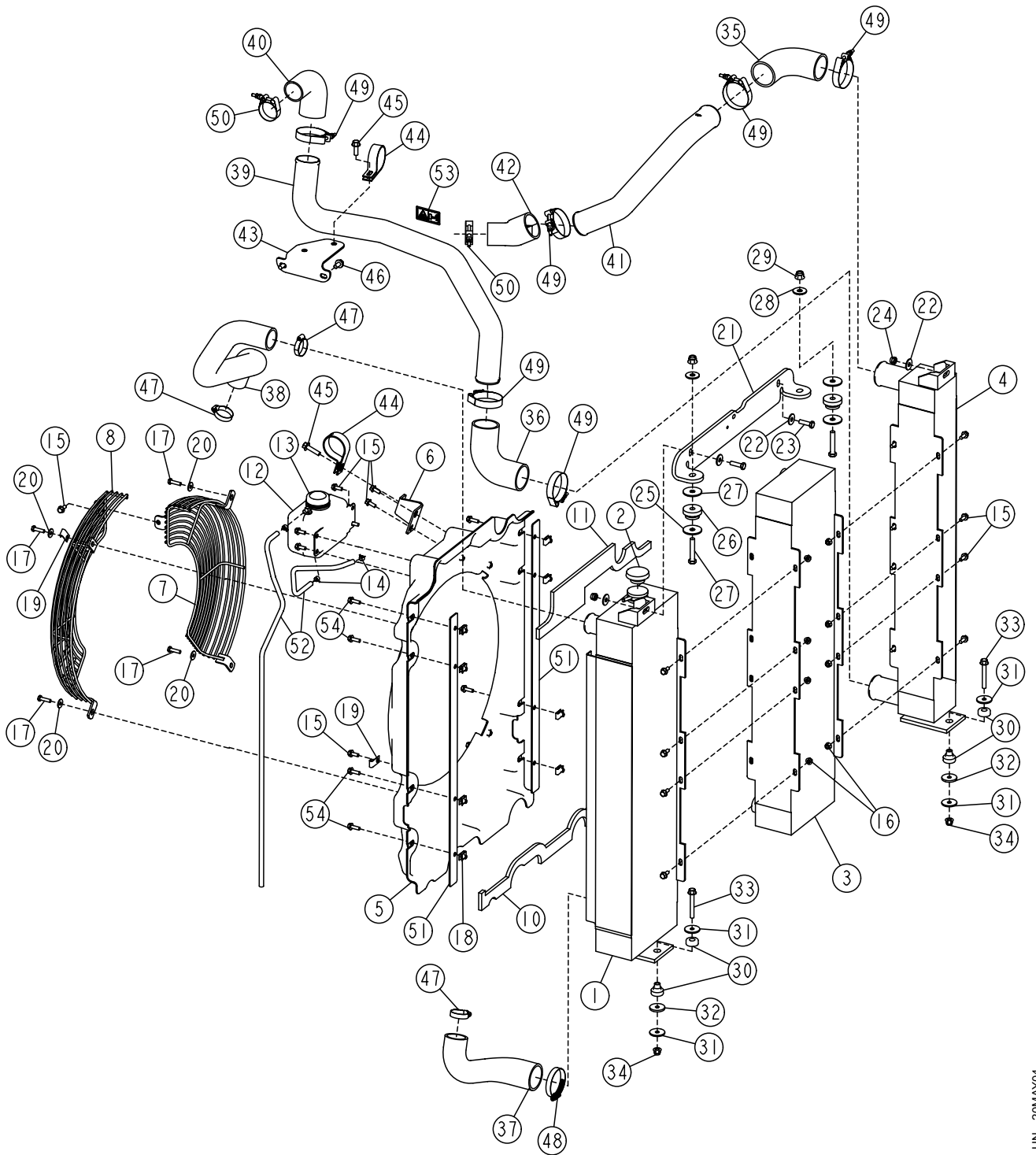

T200226

Cooling System (650J)

T200226—JUN—20MAY04

Continued on next page

DW09104.00000DA -19-26JAN04-2/4

## Radiator and Fan Shroud

1— Radiator	15— Screw (24 used)	29— Lock Nut (2 used)	43— Bracket
2— Filler Cap	16— Flange Nut (16 used)	30— Isolator (2 used)	44— Clamp (2 used)
3— Oil Cooler	17— Cap Screw (4 used)	31— Washer (4 used)	45— Screw
4— Air Cooler	18— Nut (8 used)	32— Washer (2 used)	46— Screw (2 used)
5— Shroud	19— Clamp (2 used)	33— Screw (2 used)	47— Clamp (3 used)
6— Bracket	20— Washer (4 used)	34— Lock Nut (2 used)	48— Hose Clamp
7— Guard	21— Bracket	35— Hose	49— Clamp (6 used)
8— Guard	22— Washer (4 used)	36— Screw	50— Clamp (2 used)
9— Washer (8 used)	23— Cap Screw (2 used)	37— Radiator Hose	51— Strip (2 used)
10— Deflector	24— Lock Washer (2 used)	38— Radiator Hose	52— Bulk Hose
11— Deflector	25— Nut (4 used)	39— Tube	53— Label
12— Tank	26— Isolator (2 used)	40— Hose	54— Screw (8 used)
13— Filler Cap	27— Cap Screw (2 used)	41— Tube	
14— Clip (3 used)	28— Washer (2 used)	42— Radiator Hose	

1. Remove engine side shields. Remove hood. See Hood Remove and Install. (Group 1910.)
2. Remove grille and grille housing. See Grille and Grille Housing Removal. (Group 1921.)
3. Remove fan blade and shroud. See Fan Blade and Shroud Remove and Install (650J). (Group 0510.)
4. Remove upper and lower radiator hoses. Cap and plug all openings.

5. Remove hydrostatic oil cooler hose. Cap and plug all openings.

**⚠ CAUTION: Prevent possible crushing injury from heavy component. Use appropriate lifting device.**

DW09104,00000DA -19-26JAN04-3/4

6. Remove two bottom mount cap screws (33).
7. Remove cooling package. Repair or replace as necessary.

**⚠ CAUTION: Prevent possible crushing injury from heavy component. Use appropriate lifting device.**

8. Hoist cooling package into position. Install bottom mount cap screws (33).
9. Install hoses (35 and 37). Install hydrostatic cooler hose. Cap and plug all openings.
10. Install fan blade and shroud. See Fan Blade and Shroud Remove and Install (650J). (Group 0510.)
11. Install grille and grille housing. See Grille and Grille Housing Installation. (Group 1921.)
12. Install hood. See Hood Remove and Install. (Group 1910.) Install engine side shields.

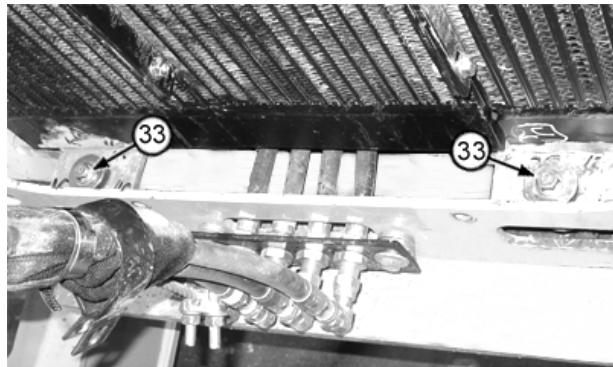

33— Cap Screw (2 used)

T193969A—UN—12AUG03

DW09104,00000DA -19-26JAN04-4/4

### Sand Shield Remove and Install

1. Remove engine side shields.
2. Remove hood. See Hood Remove and Install. (Group 1910.)
3. Remove fan blade and shroud. See Fan Blade and Shroud Remove and Install (450J, 550J) (Group 1921) or Fan Blade and Shroud Remove and Install (650J). (Group 1921.)
4. Repair or replace sand shield as necessary.
5. Install fan blade and shroud. See Fan Blade and Shroud Remove and Install (450J, 550J) (Group 1921) or Fan Blade and Shroud Remove and Install (650J). (Group 1921.)
6. Install engine side shields. Install Hood See Hood Remove and Install. (Group 1910.)

1— Sand Shield

2— Cap Screw (8 used)

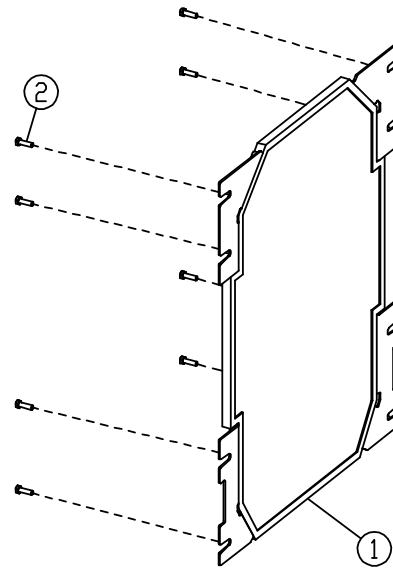

Sand Shield (650J shown)

T193857 —UN—11AUG03

CED,OUO1066,252 -19-08AUG03-1/1

*Radiator and Fan Shroud*

**Decelerator/Brake Pedal Remove and Install**

1. Loosen mounting cap screws (1).
2. Disconnect harness to decelerator sensor (2).
3. Remove cap screws and assembly.
4. Inspect and replace parts as necessary.

*NOTE: When installing assembly, verify that the round dust seal is in place on rear of support.*

5. Install assembly and tighten cap screws to specification.

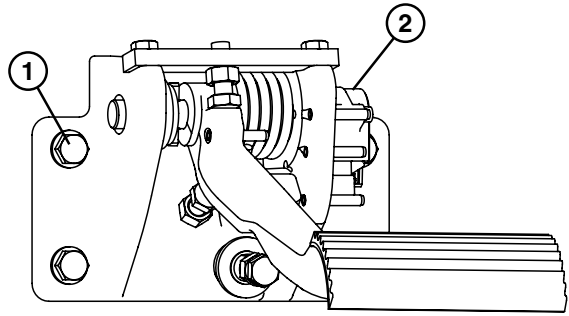

T199889 —JUN—12MAY04

<b>Specification</b>	
Decelerator Mounting	
Cap Screws—Torque.....	73 N·m 54 lb-ft

**1— Cap Screw (4 used)**

**2— Decelerator Sensor**

6. Connect harness to decelerator sensor.

MF82180,00001DA -19-07MAY04-1/1

### Decelerator/Brake Pedal Disassemble and Assemble

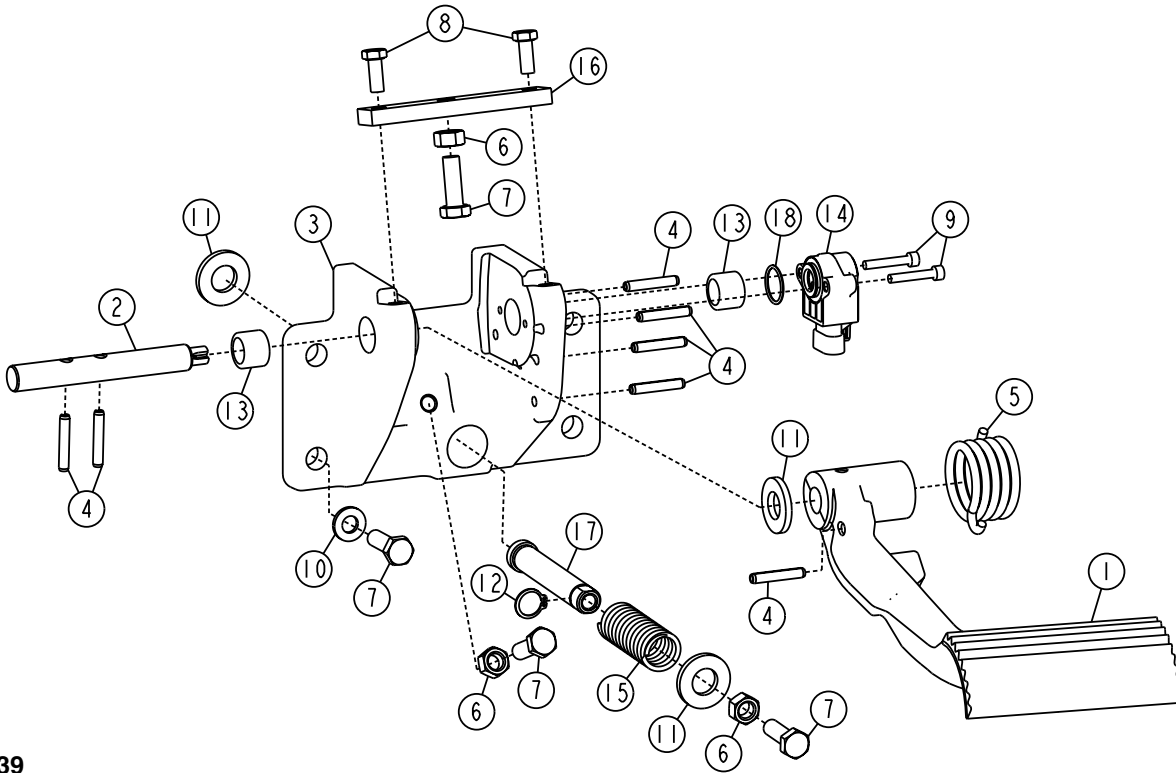

T199839

- |                        |                                   |                             |                  |
|------------------------|-----------------------------------|-----------------------------|------------------|
| 1— Pedal               | 6— Nut (3 used)                   | 11— Washer (3 used)         | 16— Stop Plate   |
| 2— Shaft               | 7— Cap Screw (7 used)             | 12— Snap Spring             | 17— Pin Fastener |
| 3— Support             | 8— Cap Screw (2 used)             | 13— Needle Bearing (2 used) | 18— O-Ring       |
| 4— Spring Pin (7 used) | 9— Hex Socket Head Screw (2 used) | 14— Decelerator Sensor      |                  |
| 5— Torsion Spring      | 10— Washer (4 used)               | 15— Spring                  |                  |

1. Remove assembly from machine. See Decelerator/Brake Pedal Remove and Install. (Group 0515.)
2. Remove hex socket head cap screws (9) securing decelerator sensor.
3. Remove decelerator sensor (14) and O-ring (18).

MF82180,00001DB -19-14JUL05-1/11

T199839 —UN—17MAY04

**CAUTION:** Decelerator pedal is under spring pressure. Removing stop plate without relieving spring pressure can cause bodily injury. Relieve spring pressure by slowly loosening cap screws and holding pressure against pedal.

4. Loosen cap screws (8) securing stop plate (16).
5. Remove cap screws (8), relieving tension in torsion spring (5).

- |                   |                       |
|-------------------|-----------------------|
| 4— Pin            | 8— Cap Screw (2 used) |
| 5— Torsion Spring | 16— Stop Plate        |

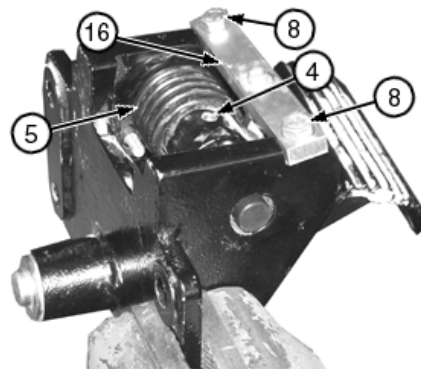

T200194A —UN—19MAY04

Continued on next page

MF82180,00001DB -19-14JUL05-2/11

## Engine Speed Control

- Remove pins (4) retaining pedal on shaft.

4— Pin (2 used)

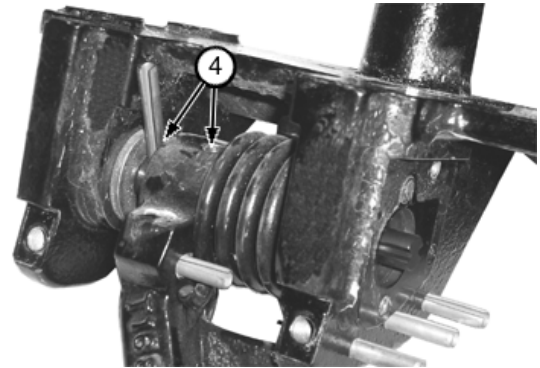

T200195A —UN—19MAY04

MF82180,00001DB -19-14JUL05-3/11

- Remove shaft (2).

2— Shaft  
5— Torsion Spring

11— Washer

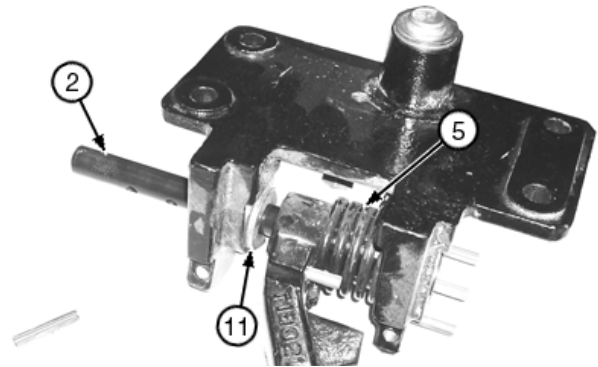

T200196A —UN—19MAY04

MF82180,00001DB -19-14JUL05-4/11

- Loosen retaining nuts (6).
- Remove cap screws (7).
- Apply pressure to washer (11) to compress spring (15) enough to remove snap ring (12).

6— Retaining Nut (2 used)      12— Snap Ring  
7— Cap Screw (2 used)        15— Spring  
11— Washer



T200197A —UN—19MAY04

Continued on next page

MF82180,00001DB -19-14JUL05-5/11

11. Remove pin fastener (17) and washer (11).
12. Disassemble remaining parts as necessary. Press out roller bearings (13) if necessary.

11— Washer

17— Pin Fastener

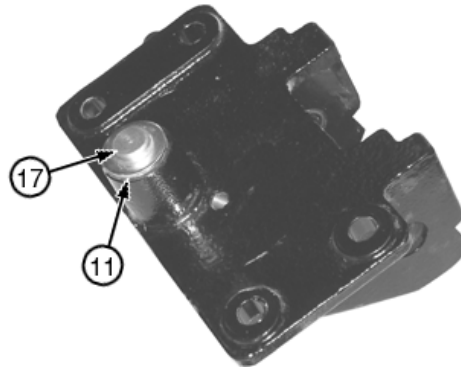

T200198A —UN—19MAY04

MF82180,00001DB -19-14JUL05-6/11

13. Press bearings (13) into support (3) to specification.

**Specification**

Bearing Placement—Distance from inside surface.....0.0—1.0 mm  
0.0—0.039 in.

14. Apply petroleum jelly to bearing rollers.

15. Install pins (4) into support (3) to specification.

**Specification**

Pin Placement—Distance from surface.....0.0—1.0 mm  
0.0—0.039 in.

16. Install pin fastener (17) through washer (11) into back of support (3).

3— Support  
4— Pin (4 used)

13— Roller Bearing (2 used)

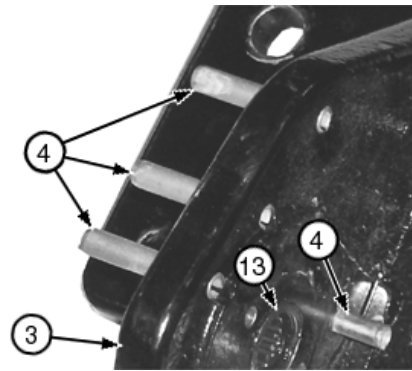

T200199A —UN—19MAY04

MF82180,00001DB -19-14JUL05-7/11

17. Install spring (15) and washer (11) onto shaft and compress to install snap ring (12).

18. Install retaining nuts (6) onto cap screws (7). Install cap screws. Tighten nuts to specification.

**Specification**

Retaining Nuts—Torque.....73 N·m  
54 lb·ft

6— Retaining Nut (2 used)  
7— Cap Screw (2 used)  
11— Washer

12— Snap Ring  
15— Spring



T200197A —UN—19MAY04

Continued on next page

MF82180,00001DB -19-14JUL05-8/11

## Engine Speed Control

19. Assemble torsion spring (5) onto pedal then rotate spring until spring is stopped by pin.
20. Place pedal with spring and washer (11) into support and install shaft (2) through assembly.

2— Shaft  
5— Torsion Spring  
11— Washer

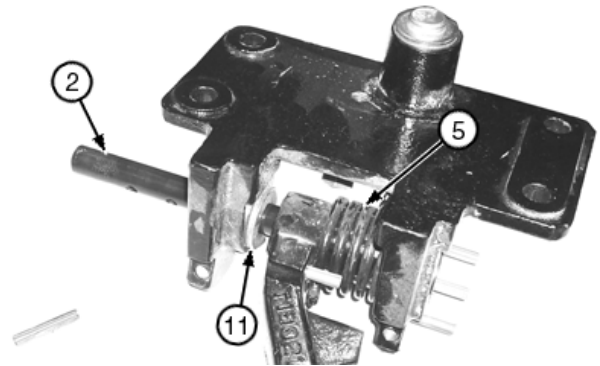

T200196A —UN—19MAY04

MF82180,00001DB -19-14JUL05-9/11

21. Verify torsion spring is installed correctly then install pin (4) into the outer hole on shaft, between washer and pedal. Verify pin has equal length on each side of shaft.
22. Rotate pedal to align the hole in the pedal and shaft. Install pin (4) into hole.

4— Pin (2 used)

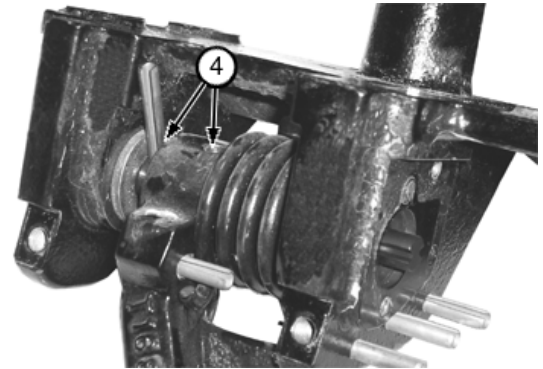

T200195A —UN—19MAY04

MF82180,00001DB -19-14JUL05-10/11

23. Secure pedal assembly and press pedal downwards. Install stop plate (16) and secure with cap screws (8). Tighten cap screws to specification.

### Specification

Stop Plate Cap	
Screws—Torque.....	37 N·m 27 lb-ft

24. Install decelerator sensor (14) with O-ring (18) onto shaft.
25. Slowly rotate sensor into position and install hex socket head cap screws (9). Tighten to specifications.

### Specification

Sensor Hex Socket Head	
Cap Screws—Torque.....	6.1 N·m 4.5 lb-ft

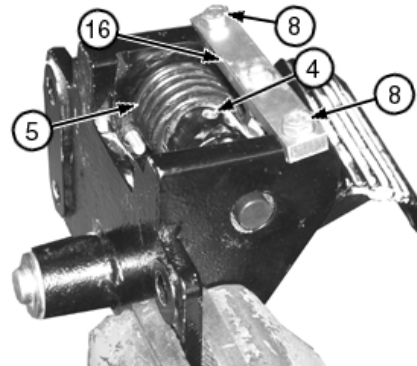

4— Pin  
5— Torsion Spring

8— Cap Screw (2 used)  
16— Stop Plate

T200194A —UN—19MAY04

26. Install assembly on machine. See Decelerator/Brake Pedal Remove and Install. (Group 0515.)
27. Perform Decelerator/Brake Pedal Adjustment. (Group 9015-20.)

MF82180,00001DB -19-14JUL05-11/11

*Engine Speed Control*

**Air Cleaner Remove and Install 550J and 650J**

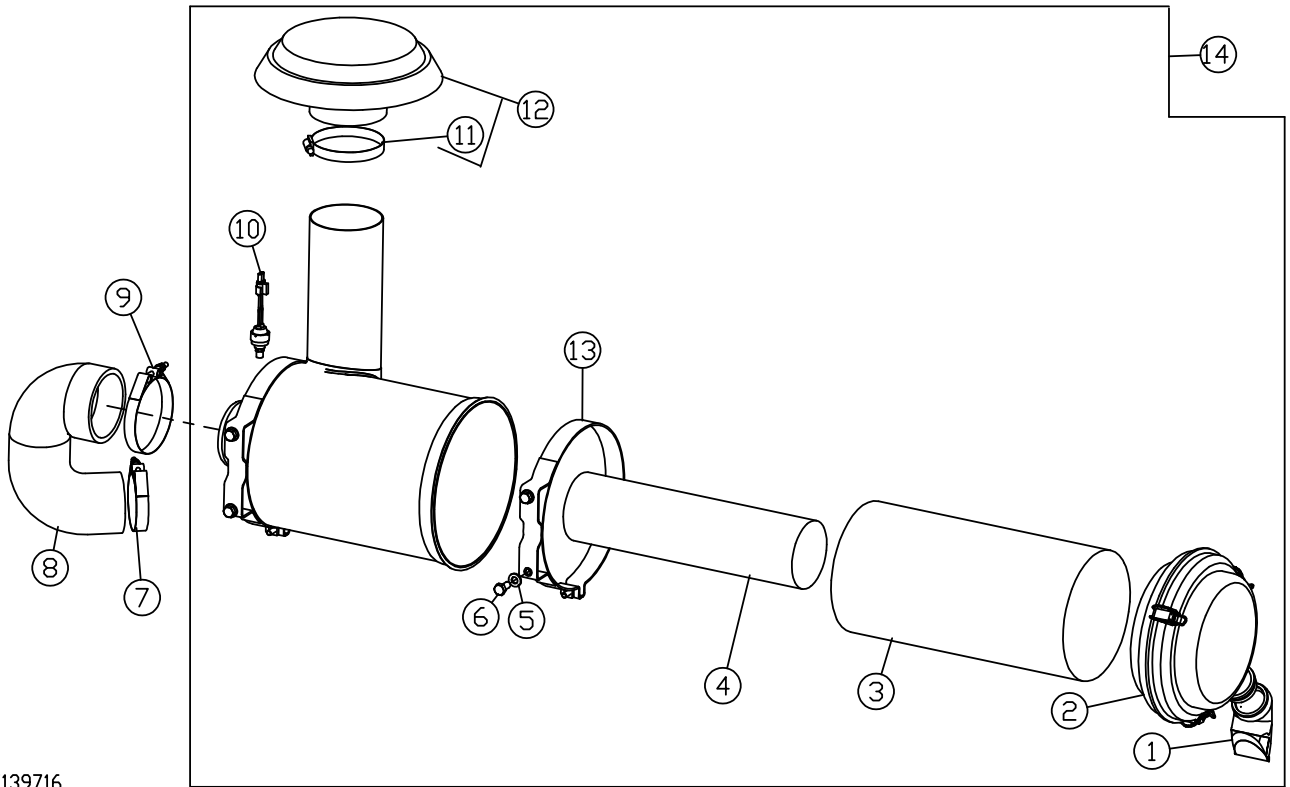

T139716

- |                      |                       |                                   |                 |
|----------------------|-----------------------|-----------------------------------|-----------------|
| 1— Valve             | 5— Washer (4 used)    | 9— Hose Clamp                     | 13— Band        |
| 2— Cover             | 6— Cap Screw (4 used) | 10— Air Filter Restriction Sensor | 14— Air Cleaner |
| 3— Primary Element   | 7— Hose Clamp         | 11— Clamp                         |                 |
| 4— Secondary Element | 8— Hose               | 12— Cap                           |                 |

1. Remove precleaner and hood.
2. Remove and install parts as needed.
3. Inspect elements for wear or damage and replace as necessary.
4. Install parts.
5. Tighten all clamps and band cap screws (9).
6. Install hood and precleaner. See Hood Remove and Install. (Group 1910.)

TX03399,00018DB -19-07MAR01-1/1

T139716 —UN—09MAR01

*Intake System*

**Muffler Without Turbocharger Remove and Install**

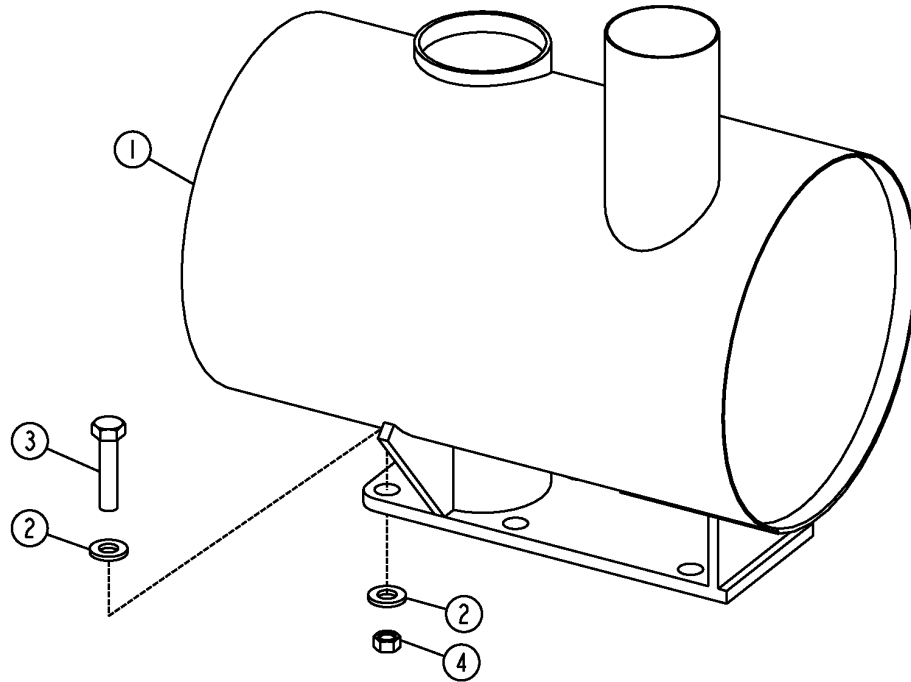

T117784

T117784 —UN—22OCT98

- |            |                     |                       |                 |
|------------|---------------------|-----------------------|-----------------|
| 1— Muffler | 2— Washer (12 used) | 3— Cap Screw (6 used) | 4— Nut (6 used) |
|------------|---------------------|-----------------------|-----------------|

1. Remove engine side shields and hood. See Hood Remove and Install. (Group 1910.)
2. Remove muffler.
3. Install muffler and tighten cap screws.

**Muffler w/o Turbocharger—Specification**

Muffler-to-Exhaust	73 N·m
Manifold—Torque.....	54 lb-ft

CED, TX03399, 5041 -19-09MAR04-1/1

**Muffler With Turbocharger Remove and Install**

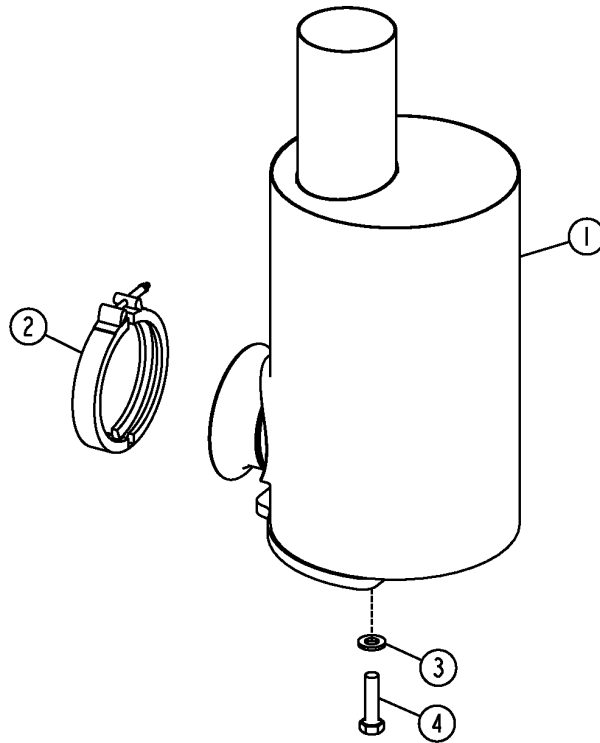

T117783

T117783—UN—22OCT98

1— Muffler

2— Clamp

3— Washer (3 used)

4— Cap Screw (3 used)

1. Remove engine side shields and hood. See Hood Remove and Install. (Group 1910.)
2. Remove muffler.
3. Install muffler and tighten cap screws.

**Muffler with Turbocharger—Specification**

Muffler-to-Exhaust	
Manifold—Torque.....	73 N·m 54 lb·ft

CED,TX03399,5043 -19-09MAR04-1/1

*External Exhaust System*

Engine and Power Train Mounting

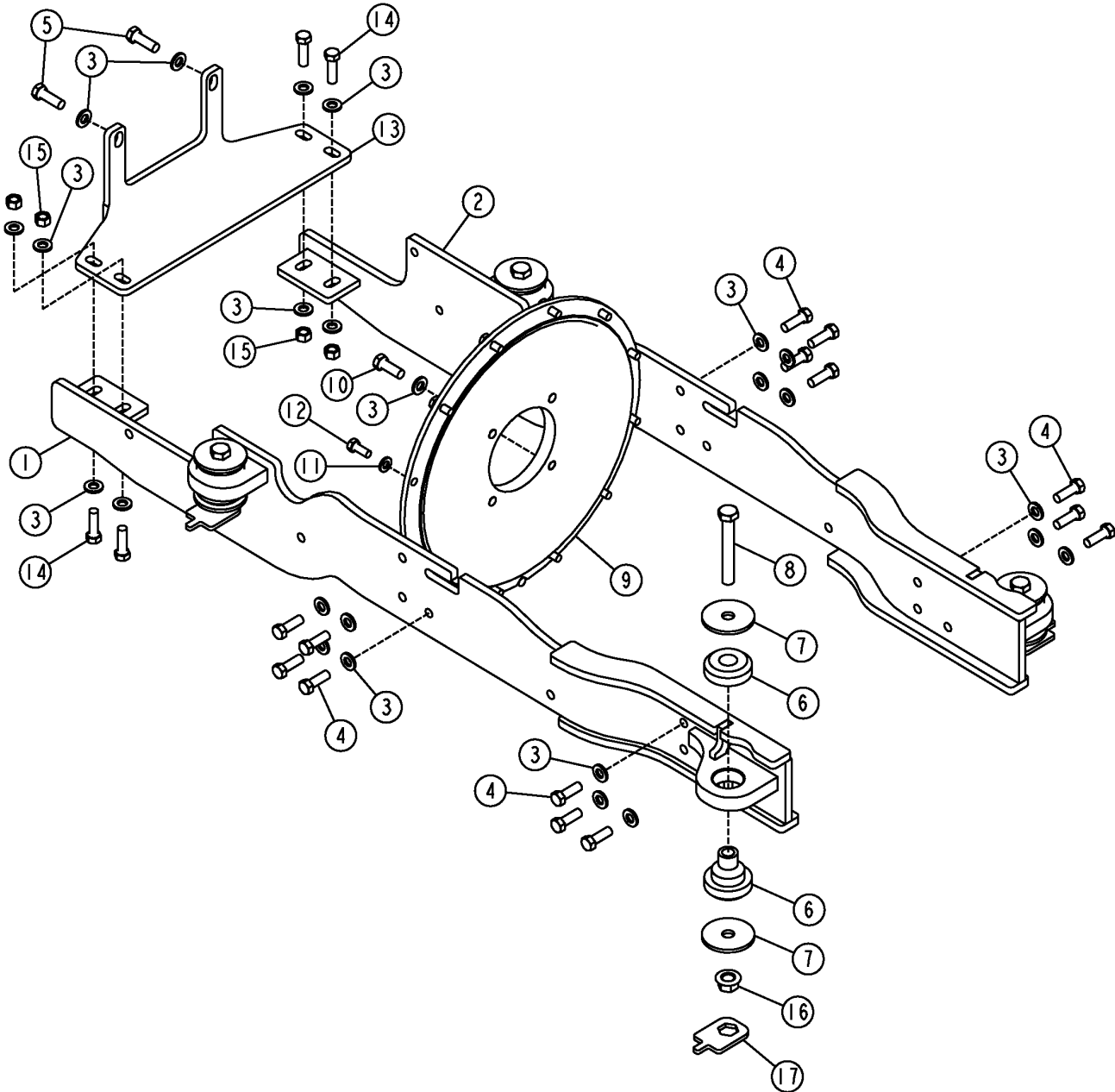

T117716

T117716—UN—22OCT98

Continued on next page

CED.TX03399,5021 -19-13APR99-1/2

## Mounting Frame

- |   |  |   |                            |
|---|--|---|----------------------------|
| 1— Right Hand Side Rail Frame                                     | 6— Rubber Mount (4 used)                       | 11— Washer (12 used)                                  | 16— Nut (4 used)           |
| 2— Left Hand Side Rail Frame                                      | 7— Washer (8 used)                             | 12— Flywheel Cover-to-Engine                          | 17— Locking Plate (4 used) |
| 3— Washer (28 used)   | 8— Side Rails-to-Main Frame Cap Screw (4 used) | Flywheel Cap Screw (12 used)                          |                            |
| 4— Front and Rear Side Rails-to-Engine Cap Screw (14 used)        | 9— Cover                                       | 13— Bracket   |                            |
| 5— Rear Support Bracket-to-Rear Hydraulic Pump Cap Screw (2 used) | 10— Pump-to-Flywheel Cover Cap Screw (4 used)  | 14— Rear Pump Support-to-Side Rail Cap Screw (4 used) |                            |
|   |  | 15— Nut (4 used)                                      |                            |

Item	Measurement	Specification
Engine and Power Train Mounting Parts		
Side Rails-to-Engine Cap Screws	Torque	130 N·m 96 lb-ft
Pump-to-Flywheel Cover Cap Screws	Torque	140 N·m 103 lb-ft
Flywheel Cover to Engine Flywheel Cap Screws	Torque	73 N·m 54 lb-ft
Rear Pump Support Bracket-to-Side Rails Cap Screws	Torque	140 N·m 103 lb-ft
Rear Support Bracket-to-Rear Hydrostatic Pump Cap Screws	Torque	140 N·m 103 lb-ft
Side Rails to Main Frame Cap Screws	Torque	320 N·m 236 lb-ft

CED, TX03399, 5021 -19-13APR99-2/2

*Mounting Frame*

## Fuel Tank Remove and Install

1. Remove cab or ROPS. See Cab or ROPS Remove and Install. (Group 1800.)
2. Remove rear access cover.
3. Drain fuel tank and disconnect fuel supply line, located by the fuel shut-off drain cock.

### Specification

Fuel Tank—Capacity..... 178 L  
47 gal

4. Cut tie band (1) and disconnect components (2—4).
5. Loosen cap screw (5) on both sides. Remove cap screws (6) and install lifting brackets.
6. Inspect fuel screen connected to the fuel shut-off valve.

**CAUTION: Prevent possible crushing injury from removing fuel tank. Use proper lifting equipment and safety precautions.**

### Fuel Tank—Specification

450J Fuel Tank—Weight..... 68 kg  
150 lb

550J and 650J Fuel Tank—Weight..... 86 kg  
190 gal

7. Attach chain and hoist to fuel tank.
8. Remove four cap screws (7) on bottom of fuel tank.
9. Install fuel tank. Tighten cap screws to specification.

### Fuel Tank—Specification

Main Frame-to-Fuel Tank Cap Screws—Torque..... 319 N·m  
235 lb-ft

Fuel Tank Brackets to Hydrostatic/Hydraulic Reservoirs—Torque..... 244 N·m  
180 lb-ft

Brackets-to-Isolators-to-Fuel Tank Cap Screws—Torque..... 87 N·m  
64 lb-ft

10. Connect components (2—4) and fuel supply line. Install new tie band (1).

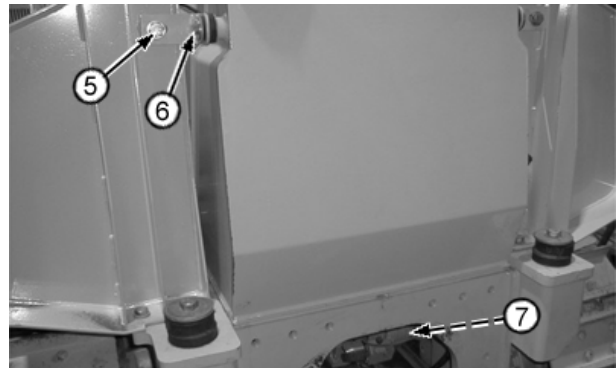
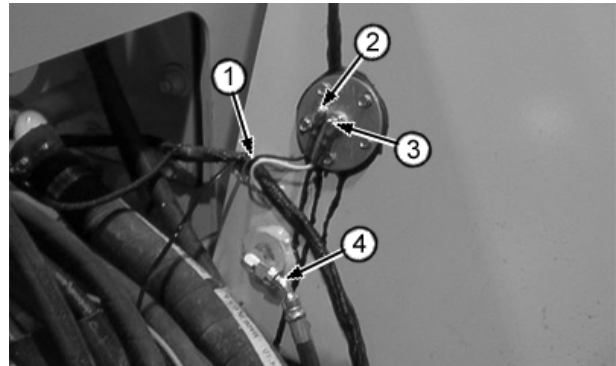

- 1— Tie Band
- 2— Black Wire Lead
- 3— Yellow Wire Lead
- 4— Fuel Return Hose

- 5— Bracket-to-Hydraulic/Hydrostatic Reservoir Cap Screw (2 used)
- 6— Bracket-to-Isolator to Fuel Tank Cap Screw (2 used)
- 7— Main Frame-to-Fuel Tank Cap Screw (4 used)

### Fuel Tank—Specification

Fuel Sender Float Cap Screws—Torque..... 10 N·m  
90 lb-in.

11. Fill fuel tank with proper amount of correct fuel.

### Fuel Tank—Specification

Fuel Tank—Capacity..... 178 L  
47 gal

T117744B —UN—19OCT98

T117888B —UN—19OCT98

CED,TX03399,5026 -19-18MAR99-1/1

*External Fuel Supply System*

**Section 07  
Dampener Drive**

**Contents**

**Page**

**Group 0752—Elements**

Dampener Drive

Remove and Install .....07-0752-1

*Contents*

**Dampener Drive Remove and Install**

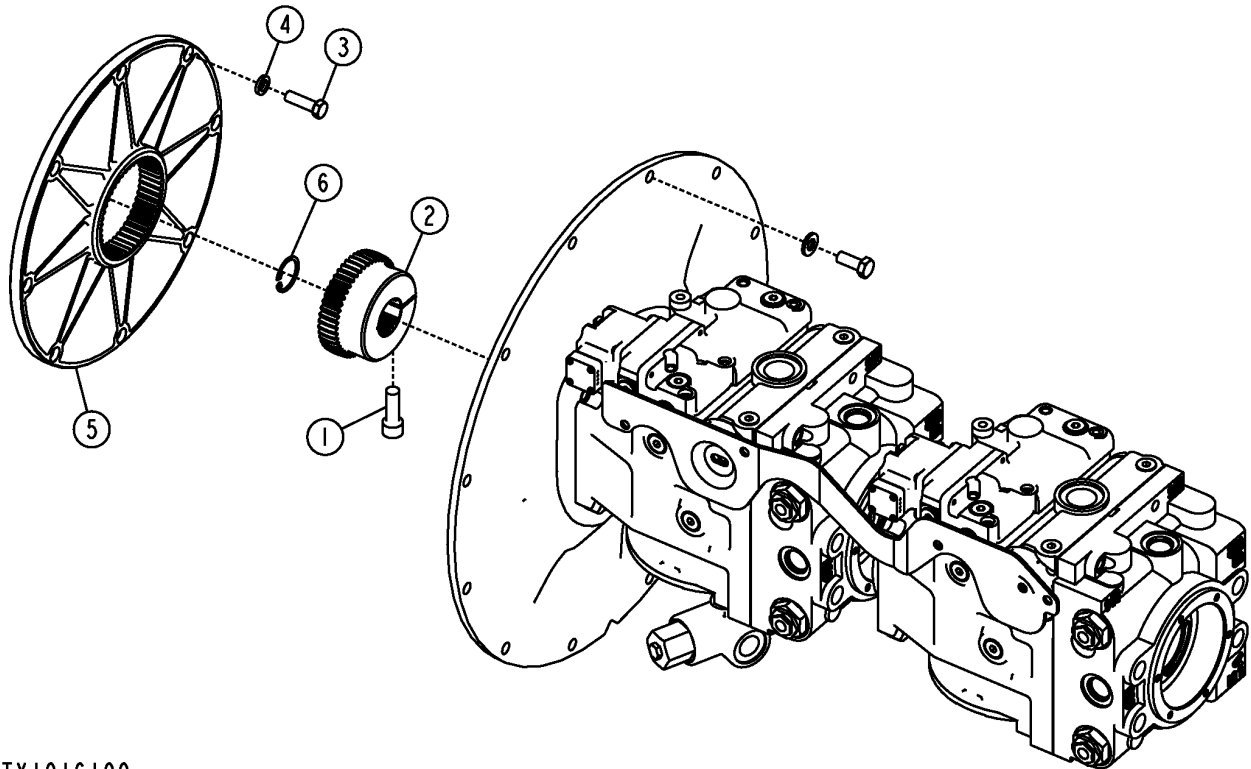

TX1016199

*Dampener Components*

1—Set Screw M12 x 35  
2—Dampener Hub

3—Cap Screw (8 used)  
4—Washer (8 used)

5—Dampener Plate  
6—Snap Ring

1. Remove hydrostatic pumps. See Hydrostatic Pump Remove and Install. (Group 0300.)
2. Remove set screw (1) from dampener hub (2).
3. Remove dampener hub. If necessary, use a puller to remove.
4. Remove cap screws (3) and dampener (5) from flywheel.
5. Install snap ring (6), in internal spline groove, of dampener hub.
6. Install new dampener hub (2) until pump shaft contacts snap ring.
7. Install set screws (1) and tighten to specification.

**Dampener Drive—Specification**

Dampener Hub-to-  
Hydrostatic Pump Shaft  
Set Screw—Torque.....86 N·m  
63 lb·ft

8. Use clean and cure primer to prepare cap screw threads and allow two minutes to cure. Apply thread lock and sealer (medium strength) to threads of cap screws (3).
9. Install new dampener plate (5) with the internal gear teeth largest offset side away from flywheel. Install cap screws (3) and washers (4) and tighten cap screws to specifications.
10. Install hydrostatic pumps. See Hydrostatic Pump Remove and Install. (Group 0300.)

**Dampener Drive—Specification**

Dampener-to-Flywheel  
Cap Screws—Torque.....57 N·m  
42 lb·ft

TX1016199—UN—05DEC06

TX.0752.SS2306 -19-06DEC06-1/1

*Elements*

**Section 11  
Park Brake**

**Contents**

**Page**

**Group 1100—Removal and Installation**  
Park Brake Valve Remove and  
Install ..... 11-1100-1  
Park Brake Remove and Install ..... 11-1100-1

**Group 1115—Control Linkage**  
Park Lock Linkage Remove and  
Install ..... 11-1115-1  
Park Lock Linkage Disassemble  
and Assemble ..... 11-1115-2

**Group 1160—Hydraulic System**  
Park Brake Valve Disassemble and  
Assemble ..... 11-1160-1  
Park Brake Disassemble and  
Assemble ..... 11-1160-2

*Contents*

# Group 1100 Removal and Installation

## Park Brake Valve Remove and Install

1. Lower all equipment to ground and stop engine.
2. Place park lock lever in UP (locked) position.
3. Turn battery disconnect switch off.
4. Disconnect hoses (1—4).
5. Disconnect harness connectors (5 and 6).
6. Remove cap screws (7) and park brake valve (8).
7. Install park brake valve (8) and tighten cap screws (7) to specification.

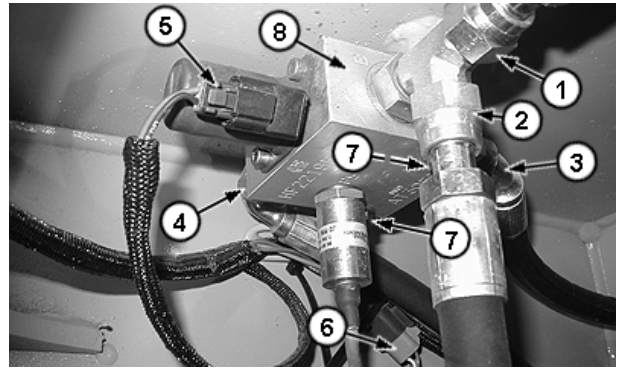

T199511A —UN—28APR04

### Specification

Park Brake Valve	
Mounting Cap	
Screws—Torque.....	37 N·m 27 lb-ft

- |  |  |
|--|--|
| <p>1—Hose (Park Brake Valve-to-Right Park Brake)</p> <p>2—Hose (Park Brake Valve-to-Left Park Brake)</p> <p>3—Hose (Park Brake Valve-to-Hydrostatic Reservoir)</p> | <p>4—Hose (Charge Pump-to-Park Brake Valve)</p> <p>5—Connector (Park Brake Valve Solenoid-to-Harness)</p> <p>6—Connector (Transmission Oil Pressure Sensor-to-Harness)</p> |
|--|--|

8. Connect harness connectors (5 and 6).
9. Connect hoses (1—4).
10. Turn battery disconnect switch to ON.

TE14778,0000023 -19-08SEP06-1/1

## Park Brake Remove and Install

1. Lower all equipment to the ground.
2. Stop engine. Operate all hydraulic controls to release pressure in the hydraulic system.
3. Turn battery disconnect switch to OFF.
4. Remove hydrostatic motor. See Hydrostatic Motor Remove and Install. (Group 0300.)
5. Disconnect park brake hose (1).
6. Remove cap screw (2).

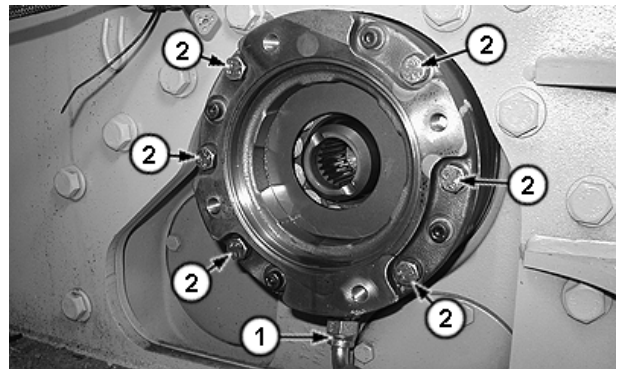

T199199A —UN—16APR04

- |                    |                       |
|--------------------|-----------------------|
| 1— Park Brake Hose | 2— Cap Screw (6 used) |
|--------------------|-----------------------|

Continued on next page

TE14778,0000024 -19-27APR04-1/6

## Removal and Installation

7.

Attach DFT1132 Hydrostatic Motor and Hydraulic Pump Removal and Installation Tool (1) to hoist with sling. See DFT1132 Hydrostatic Motor Removal and Installation Tool. (Group 9900.)

Attach DFT1211 Final Drive Lifting Bracket Adapter (2) to JT01748 Lifting Bracket (3) with cap screw. See DFT1211 Final Drive Lifting Bracket Adapter. (Group 9900.)

Attach JT01748 Lifting Bracket and DFT1132 Hydrostatic Motor and Hydraulic Pump Removal and Installation Tool to park brake with cap screw.

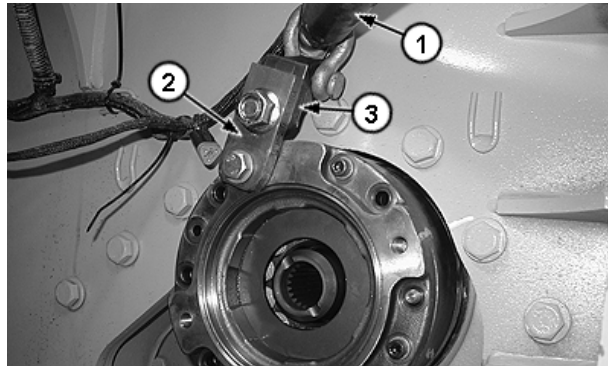

T199200A—UN—16APR04

- 1—DFT1132 Hydrostatic Motor Removal and Installation Tool  
2—DFT1211 Final Drive Lifting Bracket Adapter  
3—JT01748 Lifting Bracket

TE14778,0000024 -19-27APR04-2/6

*NOTE: Make sure coupler from final drive to park brake remains fully engaged in final drive.*

8. Install slide hammer in threaded hole using adapter. Pull park brake assembly using slide hammer while keeping coupler in final drive.

9. Remove through frame opening in rear of machine.

- 1—Slide Hammer  
2—Threaded Adapter

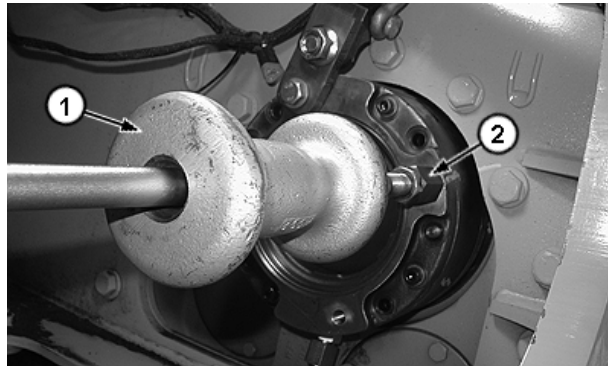

T199201A—UN—16APR04

TE14778,0000024 -19-27APR04-3/6

10. Remove O-ring (1) from park brake flange.

11. Repair or replace park brake.

12. Clean and inspect parts.

13. Apply petroleum jelly to new O-ring and install on park brake flange.

- 1—O-ring

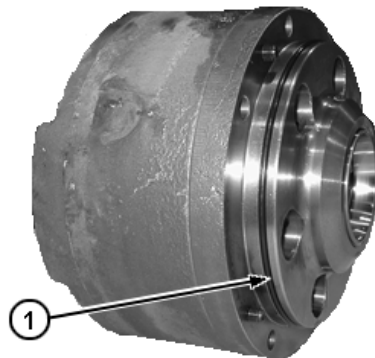

T199203A—UN—16APR04

Continued on next page

TE14778,0000024 -19-27APR04-4/6

## Removal and Installation

14. Install guide screws (1) in final drive.

Guide park brake through frame opening and position on guide screws.

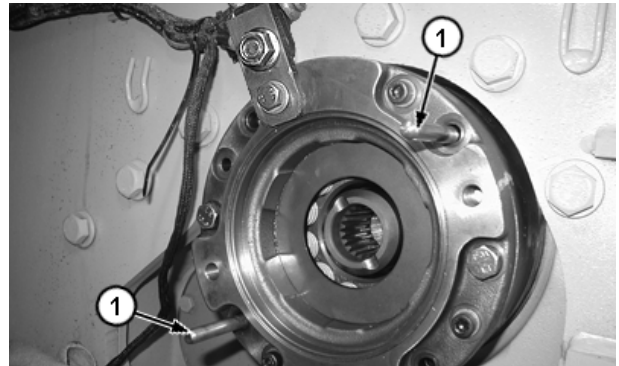

T199206A —UN—16APR04

TE14778,0000024 -19-27APR04-5/6

15. Install park brake into final drive. If necessary, move track using bottle jack under track shoe to help align final drive coupler to park brake.

16. Install two capscrews to secure park brake to final drive. Remove guide screws and install remaining capscrews.

Tighten capscrews to specification.

### Specification

Park Brake Mounting Cap

Screws—Torque.....73 N·m  
54 lb ft

17. Install park brake hose.
18. Install hydrostatic motor. See Hydrostatic Motor Remove and Install. (Group 0300.)
19. Fill reservoir if drained. See Transmission and Hydraulic Oil. (Operators Manual.)
20. Install rear access plate or rear mounted optional equipment.



T199205A —UN—16APR04

21. Replace bottom access plates if removed.

22. Turn battery disconnect switch to ON.

TE14778,0000024 -19-27APR04-6/6



## Park Lock Linkage Remove and Install

1. Lower all equipment to ground and stop engine.
2. Turn battery disconnected switch to OFF.
3. Cut tie band and disconnect park lock lever switch connector (16) from cab harness.
4. Remove control lever knob.

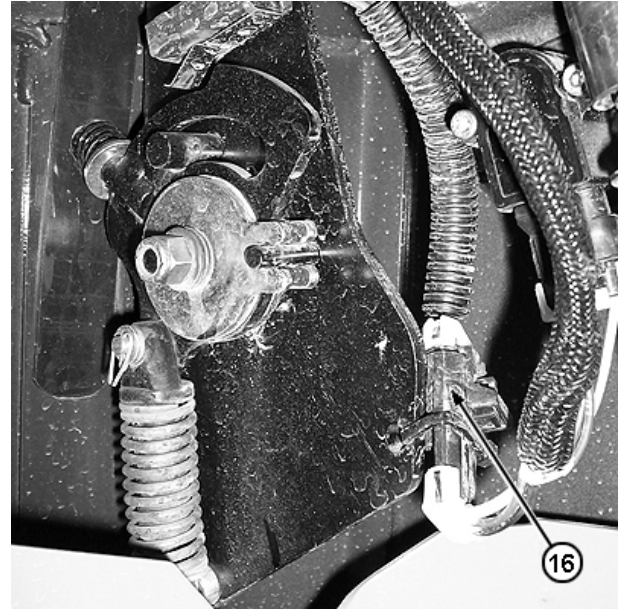

T199669A —UN—04MAY04

TE14778,000002D -19-07MAY04-1/2

5. Remove two cap screws (8) from front of left side console.
6. Remove park lock lever assembly from left side console.
7. Assemble park lock lever assembly to left side console using two cap screws (8). Tighten to specification.

### Specification

Park Lock Lever	
Mounting Cap	
Screw—Torque.....	73 N·m 54 lb-ft

8. Assemble control lever knob onto control lever. Tighten nut to specification.

### Specification

Control Lever Knob	
Nut—Torque.....	23 N·m 17 lb-ft

9. Connect park lock lever switch connector (16) to cab harness.
10. Turn battery disconnected switch to ON.

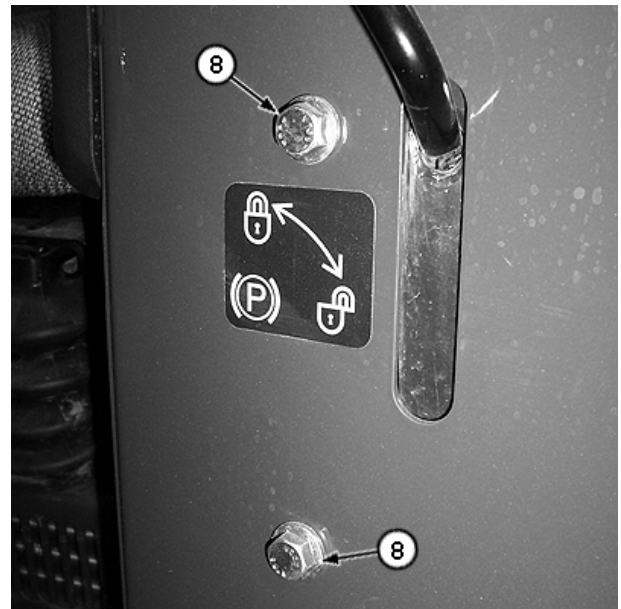

T199668A —UN—04MAY04

TE14778,000002D -19-07MAY04-2/2

## Park Lock Linkage Disassemble and Assemble

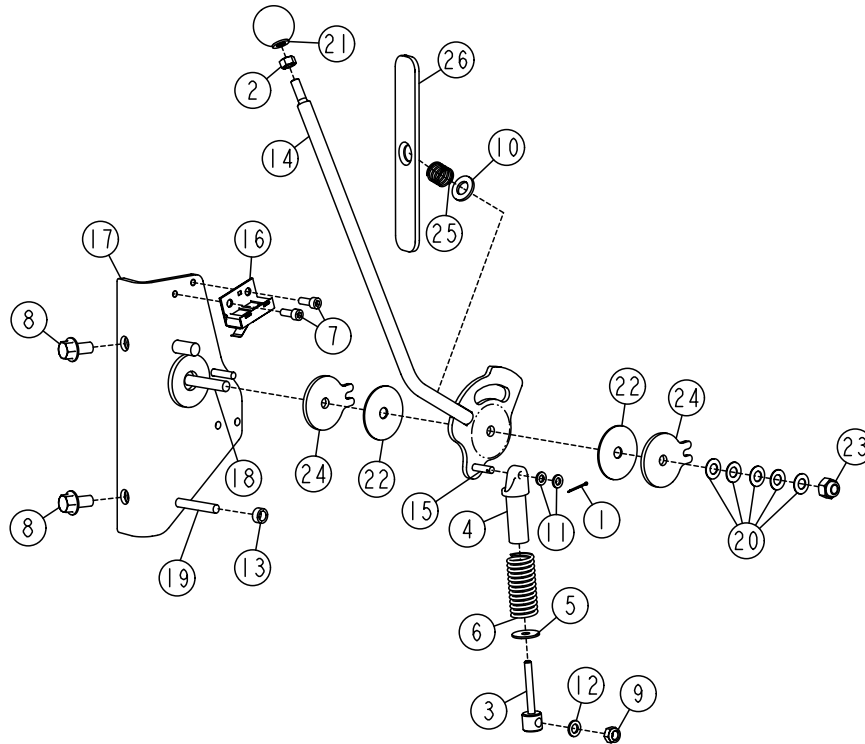

## T199655

1— Cotter Pin	8— Flanged Head Cap Screw (2 used)	15— Stud	22— Washer (2 used)
2— Nut	9— Lock Nut	16— Switch	23— Lock Nut
3— Pin Fastener	10— Washer	17— Bracket	24— Plate (2 used)
4— Pin Fastener	11— Washer (2 used)	18— Threaded Stud	25— Compressing Spring
5— Washer	12— Washer	19— Threaded Stud	26— Plate
6— Spring	13— Washer	20— Spring Washer (5 used)	27— Washer
7— Hex Socket Head Cap Screw (2 used)	14— Control Lever	21— Knob	

1. Lower all equipment to ground and stop engine.
2. Turn battery disconnect switch to OFF.
3. Remove park lock assembly. See Park Lock Linkage Remove and Install. (Group 1115.)
4. Remove plate (26), spring (25), and washer (10).
5. Remove lock nut (23), spring washers (20), plate (24), and washer (22).
6. Loosen lock nut (9) several turns. Do not remove.

Continued on next page

TE14778,000002C -19-03DEC09-1/3

T199655—UN—07MAY04

**CAUTION:** Park lock control lever is under spring pressure. Removing control lever without relieving spring pressure can cause bodily injury. Relieve spring pressure by SLOWLY removing control lever over stops and rotating lever over center.

7. Using pry bar, lift control lever (14) and pin fastener (3) until control lever is higher than stops (27 and 28). This allows lever to rotate further and relieve spring tension.
8. Remove control lever (14), pin fastener (4), spring (6), and washer (5).
9. Disassemble remaining parts.
10. Assemble pin fastener (4) onto control lever stud (15) using washers (11) and cotter pin (1).
11. Assemble pin fastener (3) onto threaded stud (19) using washers (13 and 12), and lock nut (9). Do not tighten lock nut.
12. Assemble plate (24) and washer (22) onto threaded stud (18).
13. Assemble washer (5) and compression spring (6) onto pin fastener (3).
14. With pin fastener (4) slid into compression spring (6), assemble control lever onto threaded stud (18).
15. Rotate control lever until lever fits over stops (28 and 29). Push into place.
16. Tighten lock nut (9) to specification.

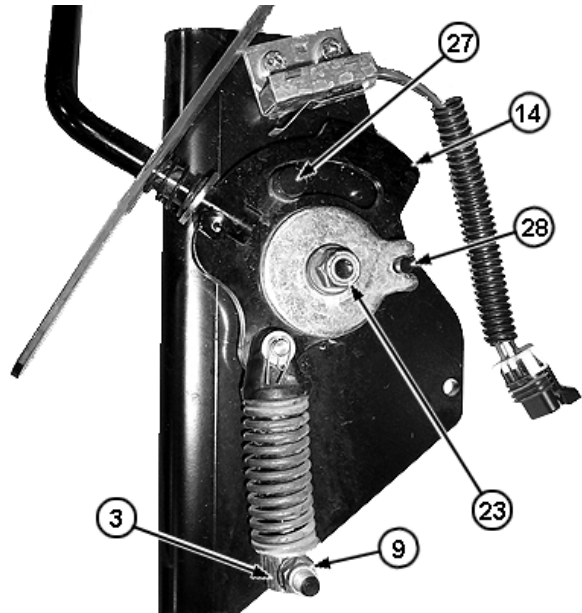

- |                   |              |
|-------------------|--------------|
| 3— Pin Fastener   | 23— Lock Nut |
| 9— Lock Nut       | 27— Stop     |
| 14— Control Lever | 28— Stop     |

**Specification**

Lock Nut (M8)—Torque..... Tighten lock nut until solid then loosen 1/2 turn.

17. Assemble washer (22) and plate (24) onto threaded stud (18).

TE14778,000002C -19-03DEC09-2/3

18. Assemble spring washers (20) as shown. Assemble lock nut (23) and tighten to specification.

**Specification**

Lock Nut (3/8)—Torque..... Tighten lock nut until solid then loosen 1/2—2 turns.

19. Assemble switch (16) onto bracket using hex socket head cap screws (7). Tighten to specification.

**Specification**

Hex Socket Head Cap Screws—Torque..... 10.4 N-m  
92 lb-in.

20. Assemble washer (10), and compression spring (25) onto control lever (14).
21. Assemble plate (26) onto control lever (14) with chamfer pointing away from spring.
22. Install park lock assembly. See Park Lock Linkage Remove and Install. (Group 1115.)

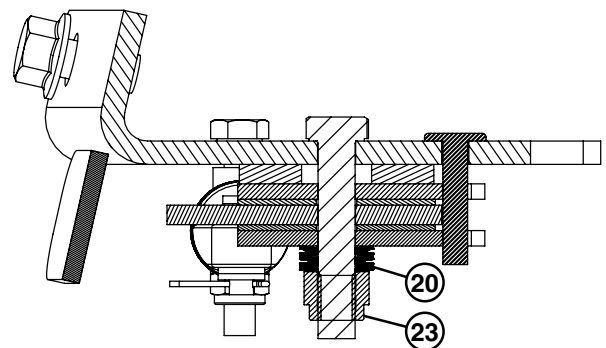

- |                             |              |
|-----------------------------|--------------|
| 20— Spring Washers (5 used) | 23— Lock Nut |
|-----------------------------|--------------|

TE14778,000002C -19-03DEC09-3/3

T199670A —UN—04MAY04

T199665 —UN—04MAY04

*Control Linkage*

## Park Brake Valve Disassemble and Assemble

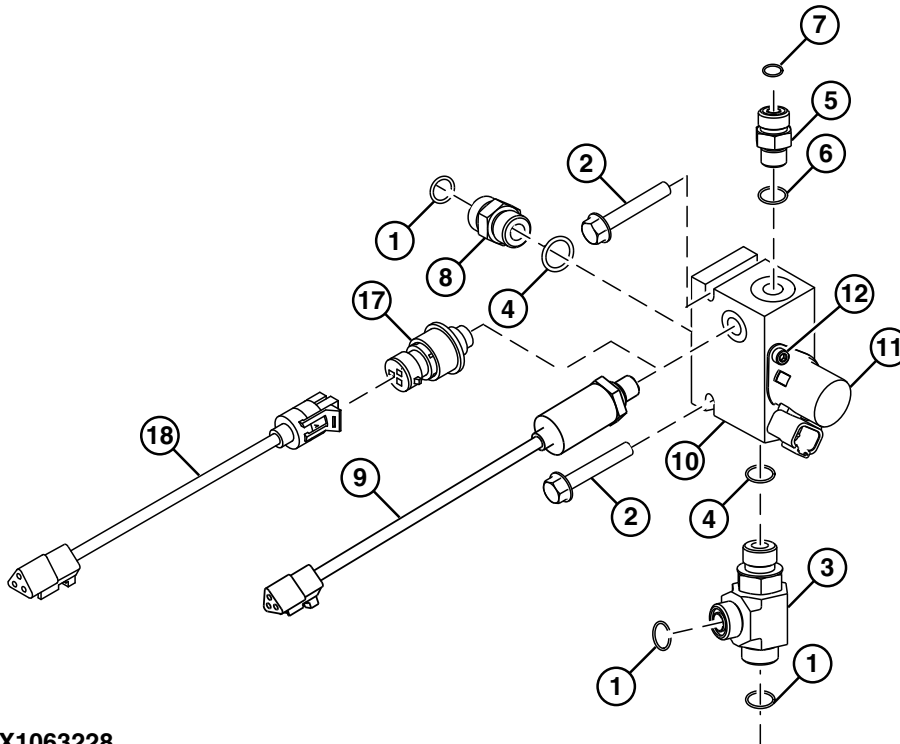

**TX1063228**

*Park Brake Valve*

- |                       |                    |  |  |
|-----------------------|--------------------|--|--|
| 1— O-Ring (3 used)    | 5— Adapter Fitting | 9— Charge Pressure Sensor (S.N. —173344) | 17— Charge Pressure Sensor (S.N. 173345— )         |
| 2— Cap Screw (2 used) | 6— O-Ring          | 10— Park Brake Valve Housing             | 18— Charge Pressure Sensor Harness (S.N. 173345— ) |
| 3— Tee Fitting        | 7— O-Ring          | 11— Solenoid Valve                       |  |
| 4— O-Ring (2 used)    | 8— Adapter Fitting | 12— Hex Socket Head Cap Screw (2 used)   |  |

1. Mark position of hydraulic tee fitting (3) to aid in assembly, and remove.
2. Remove charge pressure sensor (9 or 17).

3. Remove adapter fittings (5 and 8).

Continued on next page

TE14778.0000026 -19-22APR10-1/2

TX1063228 —UN—02SEP09

4. Remove hex socket head cap screws (12) and solenoid valve (11) from park brake valve housing (10).
5. Remove O-rings (13—16).
6. Clean and inspect parts. Replace as needed.
7. Lubricate parts with clean hydraulic oil.
8. Install O-rings (13—16) on solenoid valve.
9. Install solenoid valve (11) in park brake valve housing (10).
10. Clean threads of socket head cap screws (12). Apply PM37509 cure primer and PM37418 thread lock and sealer (medium strength) to threads of socket head cap screw (12) and tighten to specification.

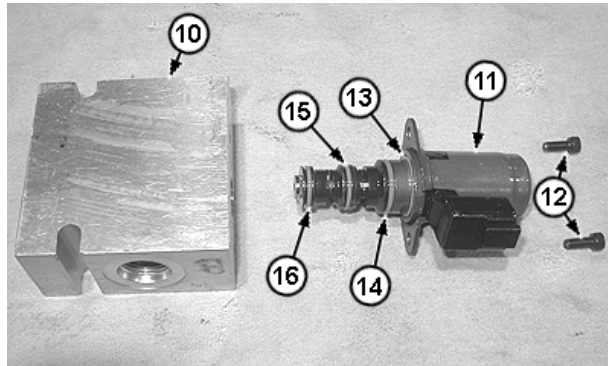

T199535A —UN—28APR04

- 10— Park Brake Valve Housing
- 11— Solenoid Valve
- 12— Hex Socket Head Cap Screw (2 used)
- 13— O-Ring
- 14— O-Ring
- 15— O-Ring
- 16— O-Ring

**Park Brake Valve—Specification**  
 Spool Socket Head Cap  
 Screw—Torque..... 9 N·m  
 80 lb.-in.

11. Install adapter fittings (5 and 8).
12. Install charge pressure sensor (9 or 17) and tighten to specification.

**Park Brake Valve—Specification**  
 Charge Pressure  
 Sensor—Torque.....20 N·m  
 177 lb.-in.

13. Install tee fitting (3) in position as marked during removal.

TE14778,0000026 -19-22APR10-2/2

### Park Brake Disassemble and Assemble

1. Remove park brake. See Park Brake Remove and Install. (Group 1100.)
2. Scribe a line between cover and housing to aid assembly.
3. Remove four socket head cap screws and washers (1) and separate cover from housing.
4. Remove O-ring from cover.

1— Socket Head Cap Screw and Washer (4 used)

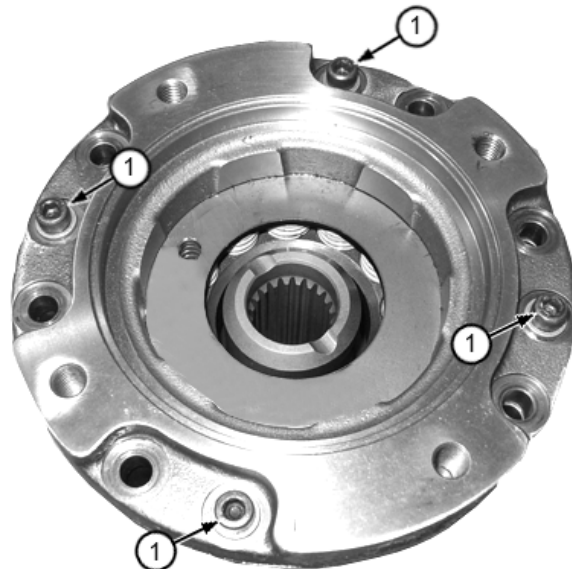

T198544A —UN—22APR04

Continued on next page

TE14778,0000025 -19-18APR06-1/8

5. Remove spring retainer plate (1).

1— Spring Retainer Plate



T198545A —UN—19MAR04

TE14778.0000025 -19-18APR06-2/8

6. Remove springs (1 and 2).

1— Springs (12 used)

2— Springs (12 used)

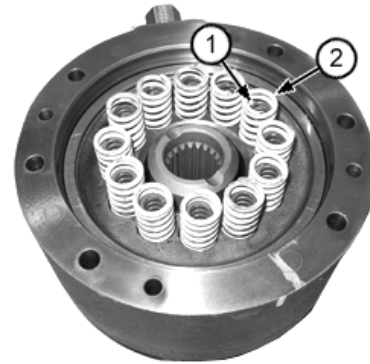

T198546A —UN—19MAR04

TE14778.0000025 -19-18APR06-3/8

7. Remove piston (1).

1— Piston

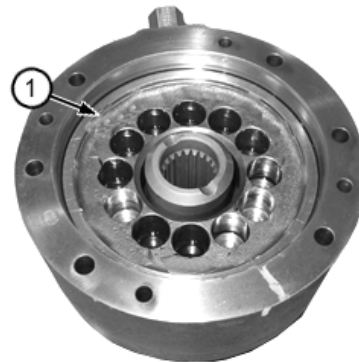

T198548A —UN—19MAR04

Continued on next page

TE14778.0000025 -19-18APR06-4/8

8. Remove O-rings (1 and 2) from piston.

1—O-Ring

2—O-Ring



T198550A —UN—19MAR04

TE14778,0000025 -19-18APR06-5/8

9. Remove splined coupling (1).

10. Scribe a line between quill and housing to aid assembly.

1—Splined Coupling

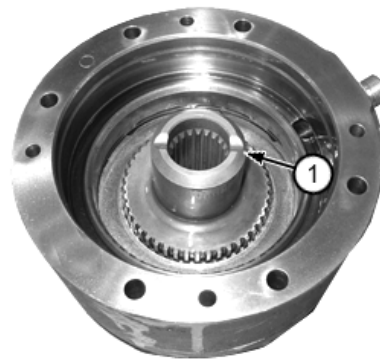

T198549A —UN—19MAR04

TE14778,0000025 -19-18APR06-6/8

11. Insert two screws (1) through housing (2) into quill.  
Tap screws with plastic hammer to separate quill from housing.

1—Screw (2 used)  
2—Housing

3—Quill

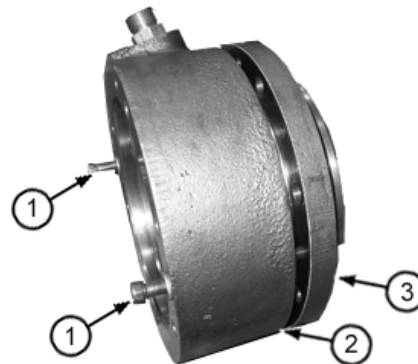

T198551A —UN—19MAR04

Continued on next page

TE14778,0000025 -19-18APR06-7/8

12. Remove friction disks (1) and separator plates (2) from housing.

Remove O-ring (3).

13. Clean and inspect parts.

14. Install splined coupling in quill.

15. Install a separator plate, then a friction disk, and continue alternating plates and disks until all are installed in quill.

16. Install O-ring on quill.

17. Apply clean hydraulic oil to O-ring, quill, and housing.

18. Install housing onto quill.

19. Install O-rings on piston.

20. Apply clean hydraulic oil to piston, O-rings, and housing.

21. Install piston in housing.

22. Install double springs into piston.

23. Install spring retainer onto springs.

24. Install O-ring on cover.

25. Apply clean hydraulic oil to cover, O-ring, and housing.

26. Install cover in housing.



1— Friction Disk (7 used)      3— O-Ring  
2— Separator Plate (8 used)

27. Install cap screws and washers. Tighten cap screws to specification.

**Park Brake—Specification**

Park Brake Assembly	
Socket Head Cap	
Screw—Torque.....	37 N·m
	27 lb·ft

T198552A —UN—19MAR04

TE14778,0000025 -19-18APR06-8/8

*Hydraulic System*

## Section 18 Operator's Station

### Contents

	Page		Page
<b>Group 1800—Removal and Installation</b>			
Cab or ROPS Remove and Install.....	18-1800-1	Cab or ROPS Under Seat Heater Disassemble and Assemble .....	18-1830-16
<b>Group 1810—Operator's Enclosure</b>		Receiver-Dryer Remove and Install .....	18-1830-18
Slide Glass Remove and Install.....	18-1810-1	Condenser Remove and Install .....	18-1830-18
Stationary Glass Remove and Install .....	18-1810-2	Compressor Remove and Install .....	18-1830-19
Sliding Window Remove and Install .....	18-1810-4	Compressor Remove and Install .....	18-1830-21
Front Window Wiper Remove and Install .....	18-1810-6	Compressor Clutch Disassemble and Assemble .....	18-1830-23
Door Window Wipers Remove and Install .....	18-1810-8	Clutch Hub Clearance Check .....	18-1830-24
Rear Window Wiper Remove and Install .....	18-1810-10	Compressor Manifold Inspect.....	18-1830-24
Front Window Wipers Remove and Install .....	18-1810-11	Compressor Disassemble and Assemble.....	18-1830-25
<b>Group 1821—Seat and Seat Belt</b>			
Standard Seat Remove and Install .....	18-1821-1		
Deluxe Seat Remove and Install .....	18-1821-5		
Air Suspension Seat Remove and Install .....	18-1821-15		
<b>Group 1830—Heating and Air Conditioning</b>			
R134a Refrigerant Cautions.....	18-1830-1		
R134a Compressor Oil Charge Check .....	18-1830-1		
R134a Compressor Oil Removal.....	18-1830-1		
R134a Component Oil Charge .....	18-1830-2		
Leakage Testing .....	18-1830-3		
R134a Refrigerant Recovery, Recycling and Charging Station Installation Procedure.....	18-1830-3		
Recover R134a System.....	18-1830-4		
Evacuate R134a System.....	18-1830-5		
Charge R134a System .....	18-1830-6		
Air Conditioner System Cleaning Procedures .....	18-1830-7		
Purge R134a System .....	18-1830-7		
Flush R134a System .....	18-1830-8		
Evaporator or Heater Core Remove and Install .....	18-1830-9		
Expansion Valve Remove and Install .....	18-1830-11		
A/C Freeze Switch Remove and Install .....	18-1830-11		
Upper Cab Heater Blower Motor and Heater Blower Resistor Remove and Install.....	18-1830-12		
Cab Upper Heater Disassemble and Assemble.....	18-1830-14		

*Contents*

# Group 1800 Removal and Installation

## Cab or ROPS Remove and Install

SPECIFICATIONS	
Cooling System Capacity	11.3 L 12 qt
<b>Cab/ROPS</b>	
Cab Weight	703 kg 1550 lb
ROPS Weight	499 kg 1100 lb
Cab/ROPS Mounting Cap Screws Torque	624 N·m 460 lb-ft
SERVICE EQUIPMENT AND TOOLS	
JT05552 Lifting Eyebolts	

1. Drain engine coolant.

### Specification

Cooling System—Capacity..... 11.3 L  
12 qt

2. **For Cabs Equipped With Air Conditioning System:**

Evacuate air conditioning system. See Evacuate R134a System. (Group 1830.)

3. Remove engine side shields and precleaner cover from machine.
4. Remove floor mat and floor plate from machine.
5. Disconnect transmission and engine main wiring harness connectors (A and B) and cable (C).

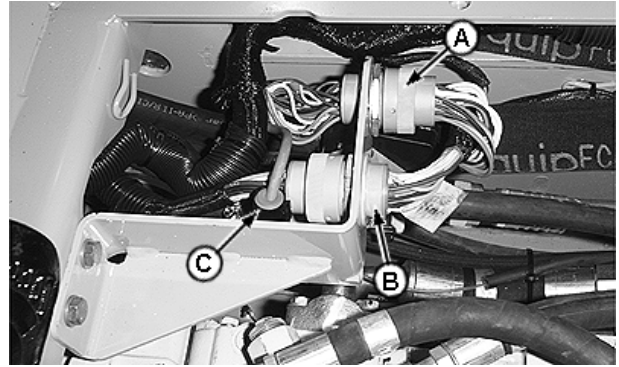

T116814B —UN—20AUG98

**A—Transmission Main Wiring Harness Connector**     **C—Cable**  
**B—Engine Main Wiring Harness Connector**

CED,TX03399,5019 -19-06APR99-1/14

6. Remove transmission controller cover.
7. Disconnect wiring harnesses (2) from transmission controller (3).

**2— Wiring Harness (2 used)     3— Transmission Controller**

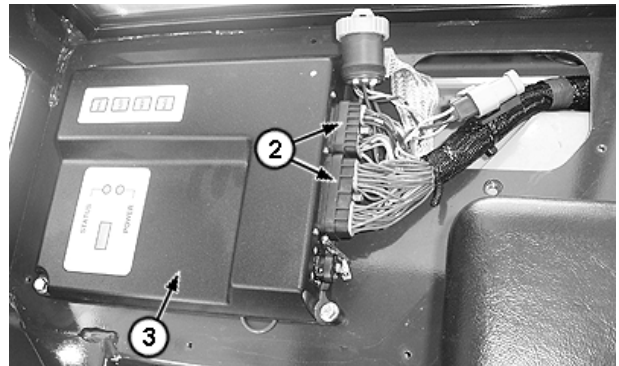

T200481A —UN—28MAY04

*Transmission Controller*

Continued on next page

CED,TX03399,5019 -19-06APR99-2/14

## Removal and Installation

8. Disconnect four wire connectors (A—D) from single lever controller (SLC). To aid in assembly, tag wires for proper location.
9. On machines equipped with dual batteries, remove rear battery.
10. Remove fuel cap and rubber boot from filler neck.
11. Remove hydraulic control tee handle.

**A**—B4 Transmission Speed Control Sensor. T07 Blue, T04 Blue, Z04 Gray Wires

**B**—B5 Left And Right Steer Sensor. (Marked BLUE on housing below sensor.) T10 Blue, T11 Blue, Z05 Gray Wires

**C**—S3 Neutral Start Switch. E09B White Wire, E03B White Wire

**D**—B2 FNR Sensor. (Marked YELLOW on housing below sensor.) T01 Blue, T02 Blue, Z01 Gray Wires

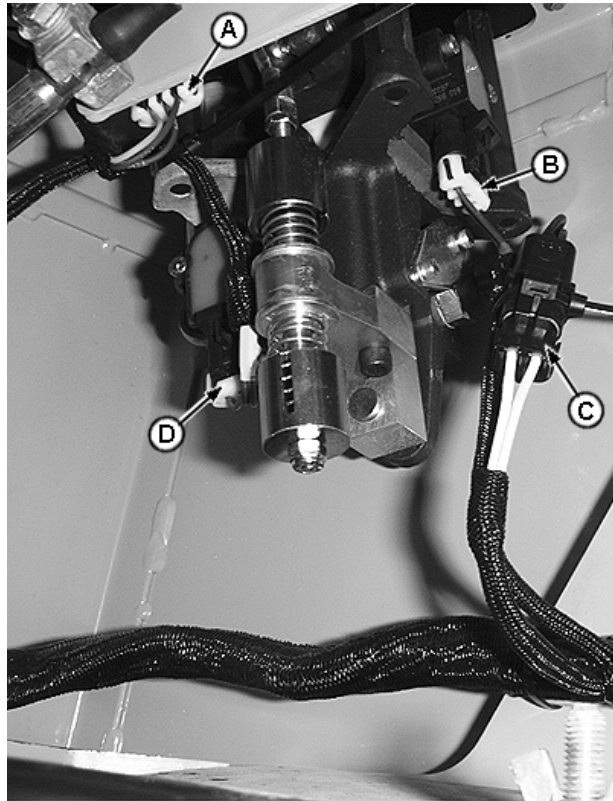

T116726B —UN—20AUG98

CED,TX03399,5019 -19-06APR99-3/14

12. Disconnect hoses (1) and (2) from engine.

**1**—Heater Hose

**2**—Heater Hose

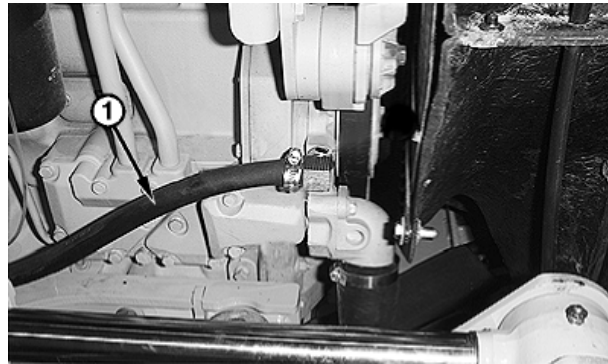

T116813C —UN—15DEC98



T117196C —UN—15DEC98

Continued on next page

CED,TX03399,5019 -19-06APR99-4/14

## Removal and Installation

13. Remove two cap screws on rear light plate and backup alarm bracket. Allow bracket to hang out back of cab.

**14. For Cabs Equipped With Air Conditioning System:**

Disconnect air conditioning hoses (1).

15. Cap and plug all openings.

**1—Air Conditioning Hose (2 used)**



T118601B —UN—15DEC98

CED,TX03399,5019 -19-06APR99-5/14

16. Remove four mounting cap screws (A) and rubber mounts.

**A—Mounting Cap Screw (4 used)**

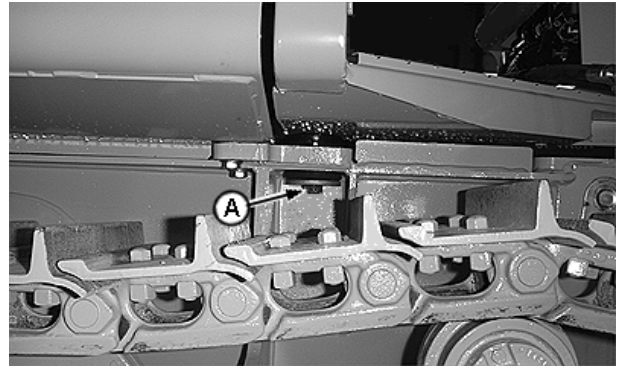

T116733B —UN—13AUG98

Continued on next page

CED,TX03399,5019 -19-06APR99-6/14

**⚠ CAUTION: Prevent possible crushing injury from cab. Use appropriate lifting device.**

**Cab/ROPS—Specification**

Cab—Weight.....	703 kg
	1550 lb
ROPS—Weight.....	499 kg
	1100 lb

**IMPORTANT: Cab/ROPS should be removed with rear end slightly higher than front end to avoid damaging rear of fuel tank.**

17. Install four JT05552 Lifting Eyebolts (A) in top of cab/ROPS.
18. Attach chain and slowly raise cab/ROPS up.
19. Remove cab or ROPS.

**A—JT05552 Lifting Eyebolts (4 used)**

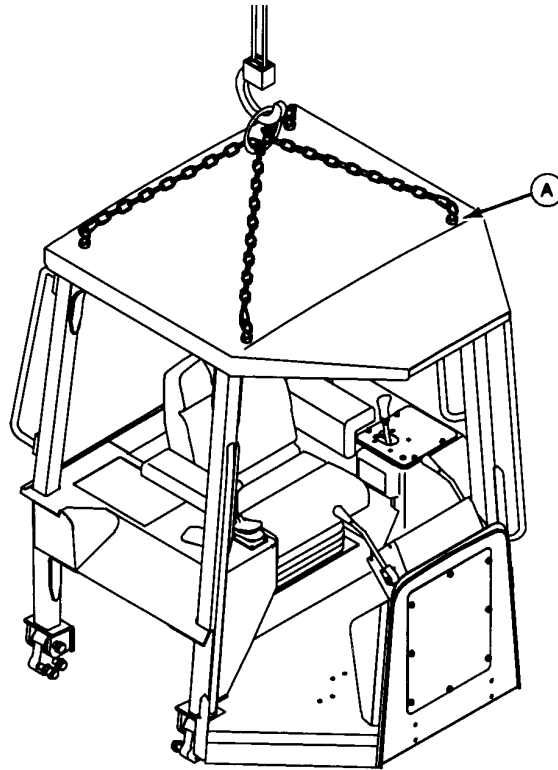

T8388AH—UN—12JUN95

Continued on next page

CED, TX03399, 5019 -19-06APR99-7/14

**IMPORTANT: Prevent possible damage to rear of fuel tank. Cab/ROPS should be installed with rear end slightly higher than front end.**

20. Install four lifting eyebolts (A) in top of cab/ROPS. Install chain and hoist.

<b>Cab/ROPS—Specification</b>	
Cab—Weight.....	703 kg 1550 lb
ROPS—Weight.....	499 kg 1100 lb

21. Slowly begin to lower cab/ROPS into place on machine.
22. When installing cab/ROPS, route all wiring harnesses back to their original location and replace all tie bands that were removed.

**A—Lifting Eyebolts (4 used)**

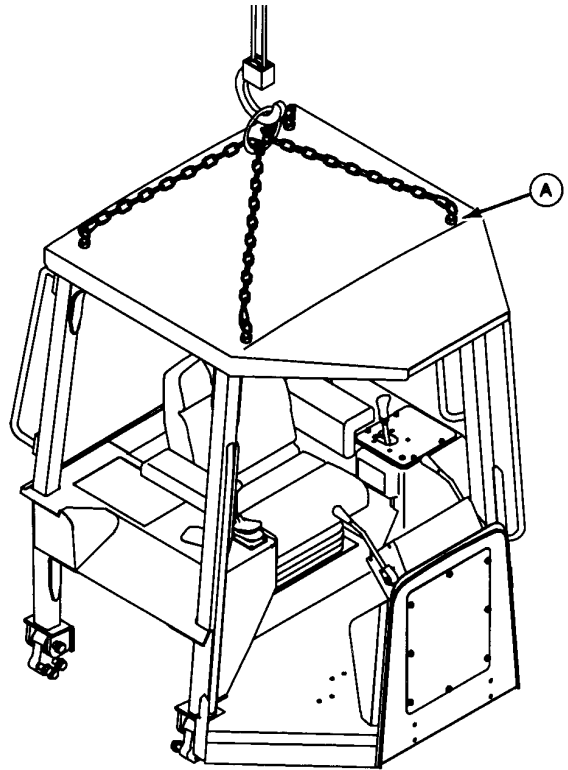

T8388AH —UN—12JUN95

CED,TX03399,5019 -19-06APR99-8/14

23. Install cab/ROPS to machine with four mounting cap screws (A) and rubber isolators. Tighten cap screws to specification.

<b>Cab/ROPS—Specification</b>	
Cab/ROPS Mounting	
Cap Screws—Torque.....	624 N·m 460 lb·ft

**A—Mounting Cap Screw (4 used)**

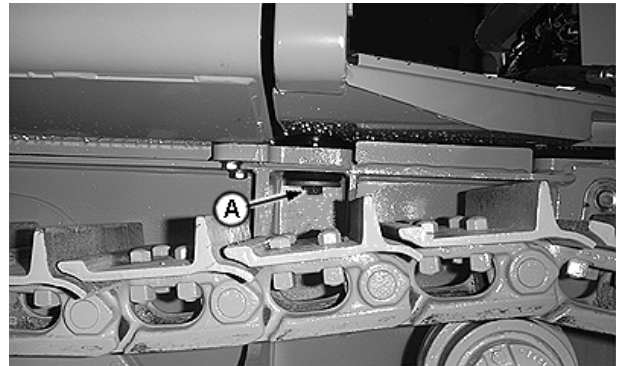

T116733B —UN—13AUG98

Continued on next page

CED,TX03399,5019 -19-06APR99-9/14

Removal and Installation

**24. For Cabs Equipped With Air Conditioning System:**

Verify O-rings are present and in good condition on air conditioning hoses and apply refrigerant oil.

Connect air conditioning hoses (1) as shown.

**25. Install rear light plate and backup alarm bracket to cab using two cap screws.**

**1— Air Conditioning Hose (2 used)**

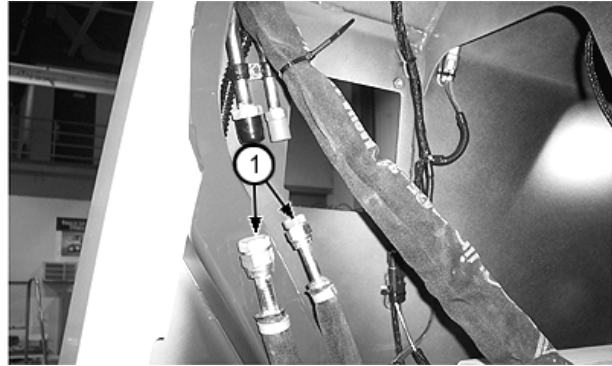

T200472A —UN—28MAY04

CED,TX03399,5019 -19-06APR99-10/14

**26. Connect heater hoses (1) and (2) to engine.**

**27. Install boot and hydraulic control tee handle.**

**28. On machines equipped with dual batteries, install rear battery.**

**1— Heater Hose**

**2— Heater Hose**

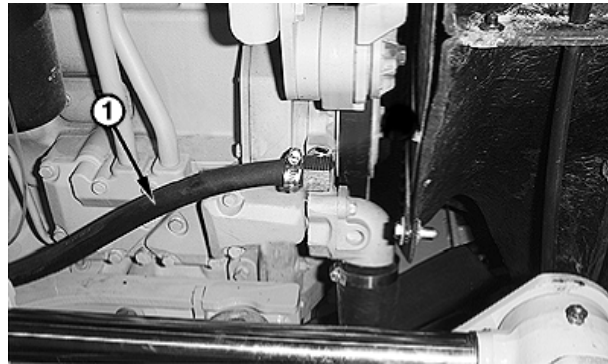

T118813C —UN—15DEC98



T117195C —UN—15DEC98

Continued on next page

CED,TX03399,5019 -19-06APR99-11/14

## Removal and Installation

29. Connect four wire connectors (A—D) on single lever control (SLC).

**A**—B4 Transmission Speed Control Sensor. T07 Blue, T04 Blue, Z04 Gray Wires

**B**—B5 Left And Right Steer Sensor. (Marked BLUE on housing below sensor.) T10 Blue, T11 Blue, Z05 Gray Wires

**C**—S3 Neutral Start Switch. E09B White Wire, E03B White Wire

**D**—B2 FNR Sensor. (Marked YELLOW on housing below sensor.) T01 Blue, T02 Blue, Z01 Gray Wires

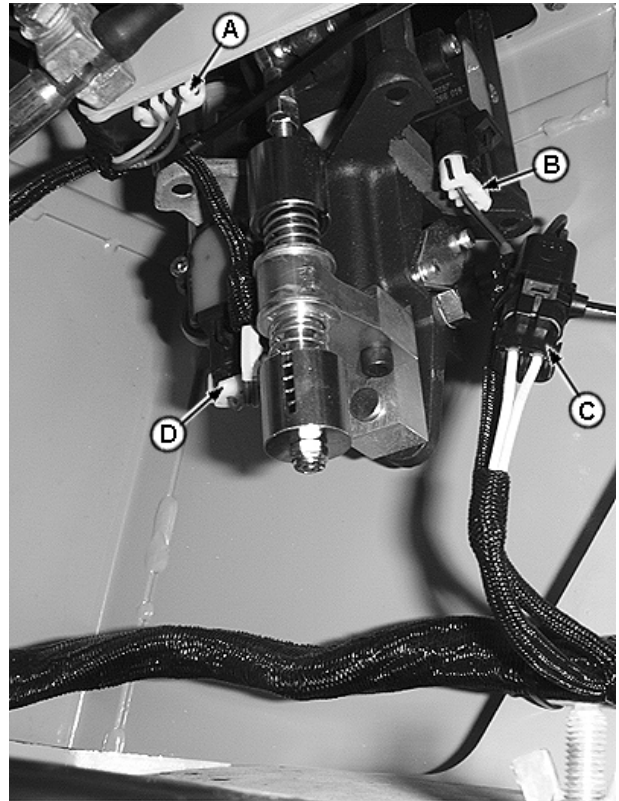

T116726B —UN—20AUG98

CED,TX03399,5019 -19-06APR99-12/14

30. Connect wiring harnesses (2) to transmission controller (3).

31. Install transmission controller cover.

**2**— Wiring Harness (2 used)

**3**— Transmission Controller

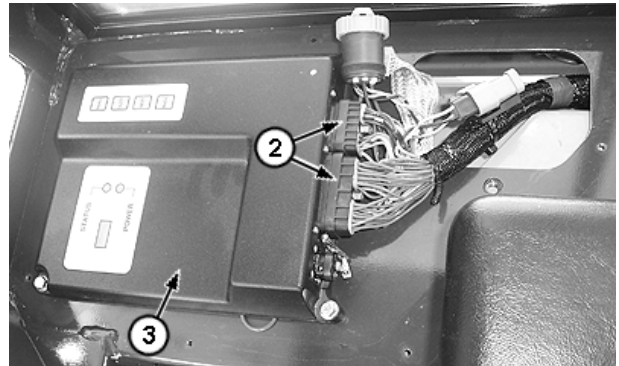

T200481A —UN—28MAY04

Continued on next page

CED,TX03399,5019 -19-06APR99-13/14

Removal and Installation

- 32. Connect transmission and engine main wiring harness connectors (A and B) and cable (C).
- 33. Install floor plate and floor mat.
- 34. Install molding strip to front of cab/ROPS.
- 35. Fill engine coolant.

**Cab/ROPS—Specification**

Cooling System—Capacity.....	11.3 L
	12 qt

- 36. Install engine side shields and precleaner cover.
- 37. Install boot on fuel filler neck and install fuel cap.
- 38. **For Cabs Equipped With Air Conditioning System:**  
Charge air conditioning system. See Charge R134a System. (Group 1830.)

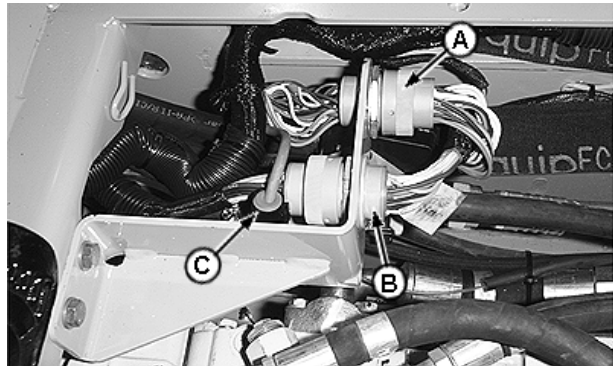

T116814B —UN—20AUG98

**A—Transmission Main Wiring Harness Connector**      **C—Cable**  
**B—Engine Main Wiring Harness Connector**

CED, TX03399, 5019 -19-06APR99-14/14

Slide Glass Remove and Install

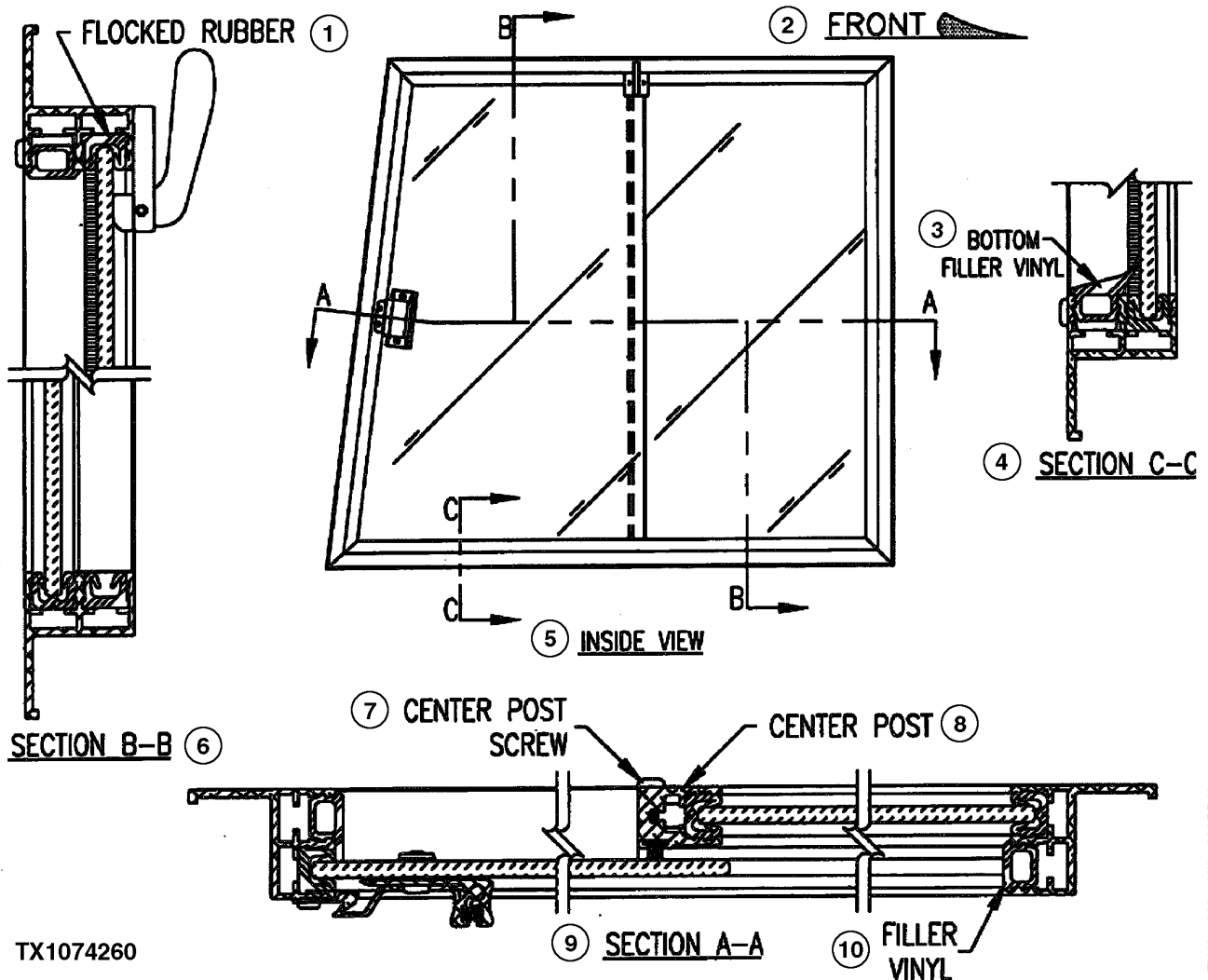

TX1074260

Sliding Glass Components

- |                        |                |                      |                  |
|------------------------|----------------|----------------------|------------------|
| 1— Flocked Rubber      | 4— Section C—C | 7— Center Post Screw | 10— Filler Vinyl |
| 2— Front               | 5— Inside View | 8— Center Post       |                  |
| 3— Bottom Filler Vinyl | 6— Section B—B | 9— Section A—A       |                  |

1. Move the slide glass to the closed position.
2. Starting at the front of the window, begin removing the flocked rubber from the channel behind the glass at the top front of the window (approximately 76 mm [3 in.] of this section of rubber extends under the glass). Slide this portion out in order to completely remove flocked rubber section.
3. Slide the glass to the front of the window and lift it up into the open channel left by removing the flocked rubber. This will allow the glass to clear the bottom channel and be removed by tilting the bottom toward the inside of the window.
4. Install new glass with the bottom of the glass tilted toward the inside of window. Lift window up into the open channel at the top of the window until the bottom of the glass can be inserted into the bottom channel.
5. Slide the glass into the rear section of flocked rubber still in the frame and move it to the closed position.
6. Reinstall the front section of the flocked rubber by first working it in between the top of the glass and the channel until it meets up with the rear section (coating the end of the rubber with soapy water will aid in installing the flock).
7. Insert the opposite end of the rubber into the end of the channel. Push in and smooth out the middle portion.

CED, TX03768, 2514 -19-22MAR10-1/1

TX1074260 —JUN—22APR10

### Stationary Glass Remove and Install

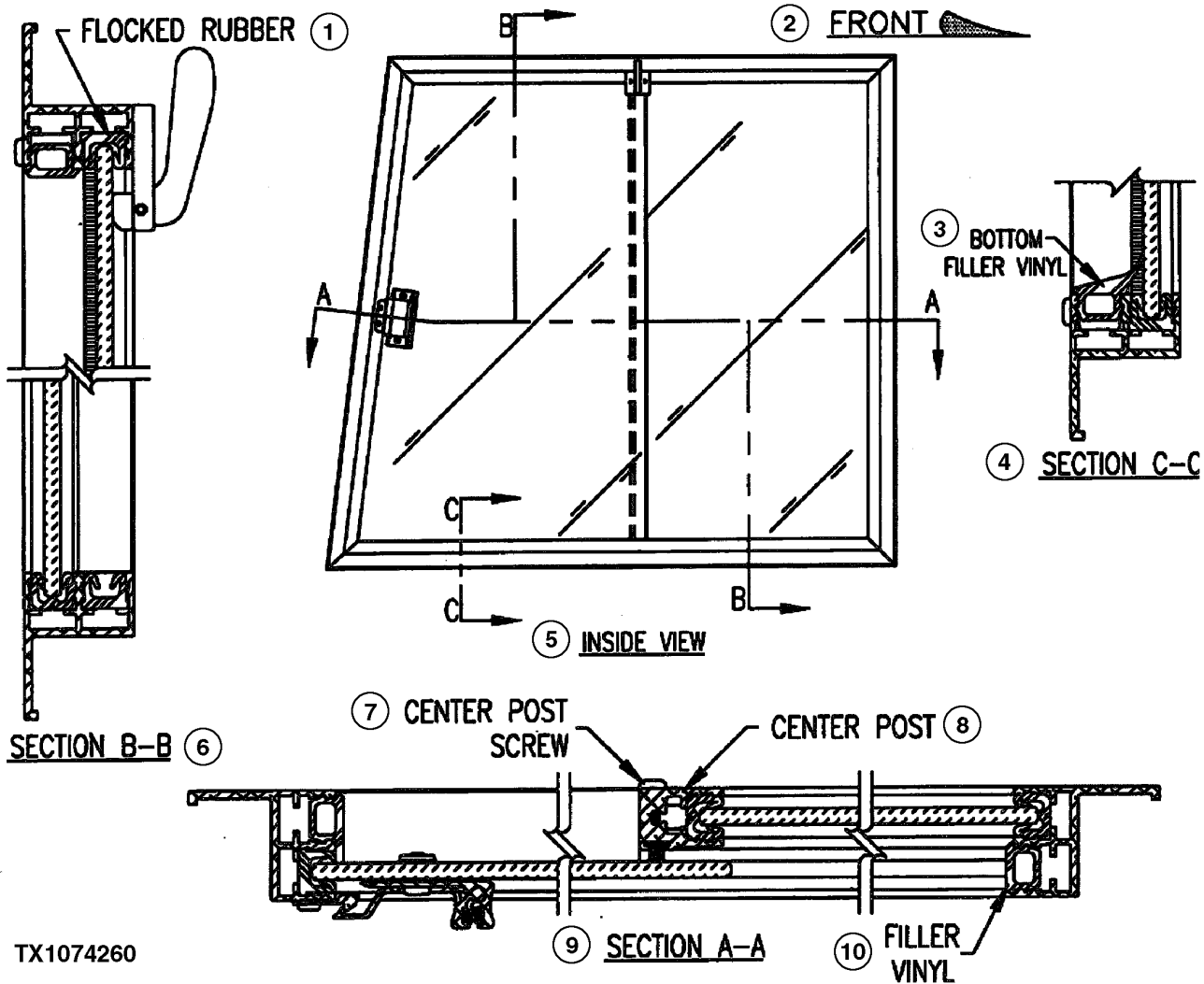

TX1074260

TX1074260 —UN—22APR10

Stationary Glass Components

- |                        |                |                      |                  |
|------------------------|----------------|----------------------|------------------|
| 1— Flocked Rubber      | 4— Section C—C | 7— Center Post Screw | 10— Filler Vinyl |
| 2— Front               | 5— Inside View | 8— Center Post       |                  |
| 3— Bottom Filler Vinyl | 6— Section B—B | 9— Section A—A       |                  |

- From the outside of the window and using a screwdriver, remove the filler vinyl and center post screws (the filler vinyl is held into the channel by compression only). The two center post screws are located on the outside face of the frame at both ends of the center post.
- With the screws removed, pull back on the center post to remove it from the glass.
- Slide the glass back until it clears the flocked rubber in the frame channel. Lift the glass up into the now open channel of the frame until the bottom of the glass can be swung clear.
- To install new glass, tilt bottom of glass toward the outside of window, lift it up into the open channel behind the flocked rubber at the top of the window until the bottom of glass can be inserted into the bottom channel.
- Slide the glass into the flocked rubber until it is fully seated in the front channel.
- Reinstall the center post assembly by tilting it until the milled ends can be inserted into the channel behind the glass and push it on to the glass. (The screw holes in the frame will align with the holes in the center post when stationary glass and center post have been properly installed.)
- Fasten the center post screws and push filler vinyls back into the channels. Press vinyl in at both ends and then the middle (vinyls may appear to be too long, but is important not to cut them.)

CED, TX03768, 2515 -19-22MAR10-1/1

*Operator's Enclosure*

### Sliding Window Remove and Install

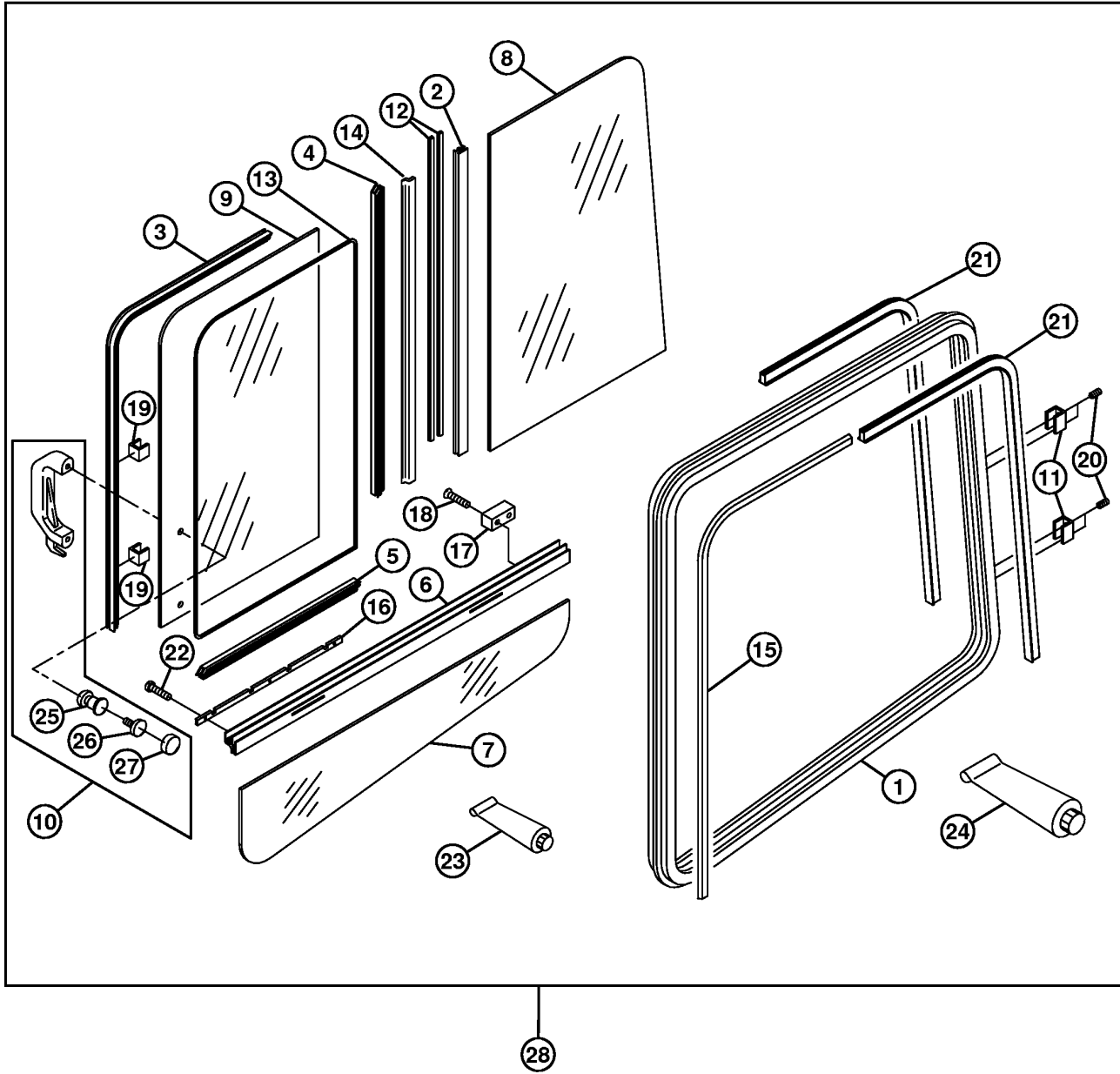

T213246

Cab Sliding Side Window

T213246—UN—04OCT05

Continued on next page

CED, TX14826, 12085 -19-17AUG99-1/2

*Operator's Enclosure*

1— Frame	8— Windowpane, Fixed	15— Isolator	22— Screw (3 used)
2— Guard	9— Windowpane, Sliding	16— Rail	23— Adhesive
3— Frame	10— Handle	17— Stop	24— Liquid Gasket
4— Frame	11— Sheet (2 used)	18— Screw (2 used)	25— Sleeve (2 used)
5— Frame	12— Brush (2 used)	19— Guide (7 used)	26— Screw (2 used)
6— Guide	13— Isolator (3 used)	20— Set Screw (3 used)	27— Cover (2 used)
7— Windowpane, Fixed	14— Isolator	21— Isolator (3 used)	28— Windowpane (complete)

CED, TX14826, 12085 -19-17AUG99-2/2



Operator's Enclosure

1— Hose	10— Tie Band (As Required)	19— Screw (3 used)	28— Washer
2— Reducer	11— Wiper Motor	20— Grommet (3 used)	29— Screw (2 used)
3— Hose	12— Bracket	21— Screw (2 used)	30— Pivot Plate
4— Shaft Assembly	13— Washer	22— Washer (2 used)	31— Pin
5— Nut	14— Lock Nut	23— Bushing	32— Washer
6— Lock Washer	15— Clip (2 used)	24— Nut	33— Jam Nut
7— Wiper Arm	16— Washer (2 used)	25— Cap	34— Switch
8— Grommet	17— Link Assembly	26— Nut	
9— Wiper Blade	18— Arm	27— Washer	

CED,OUTX547,211 -19-22OCT98-2/2

### Door Window Wipers Remove and Install

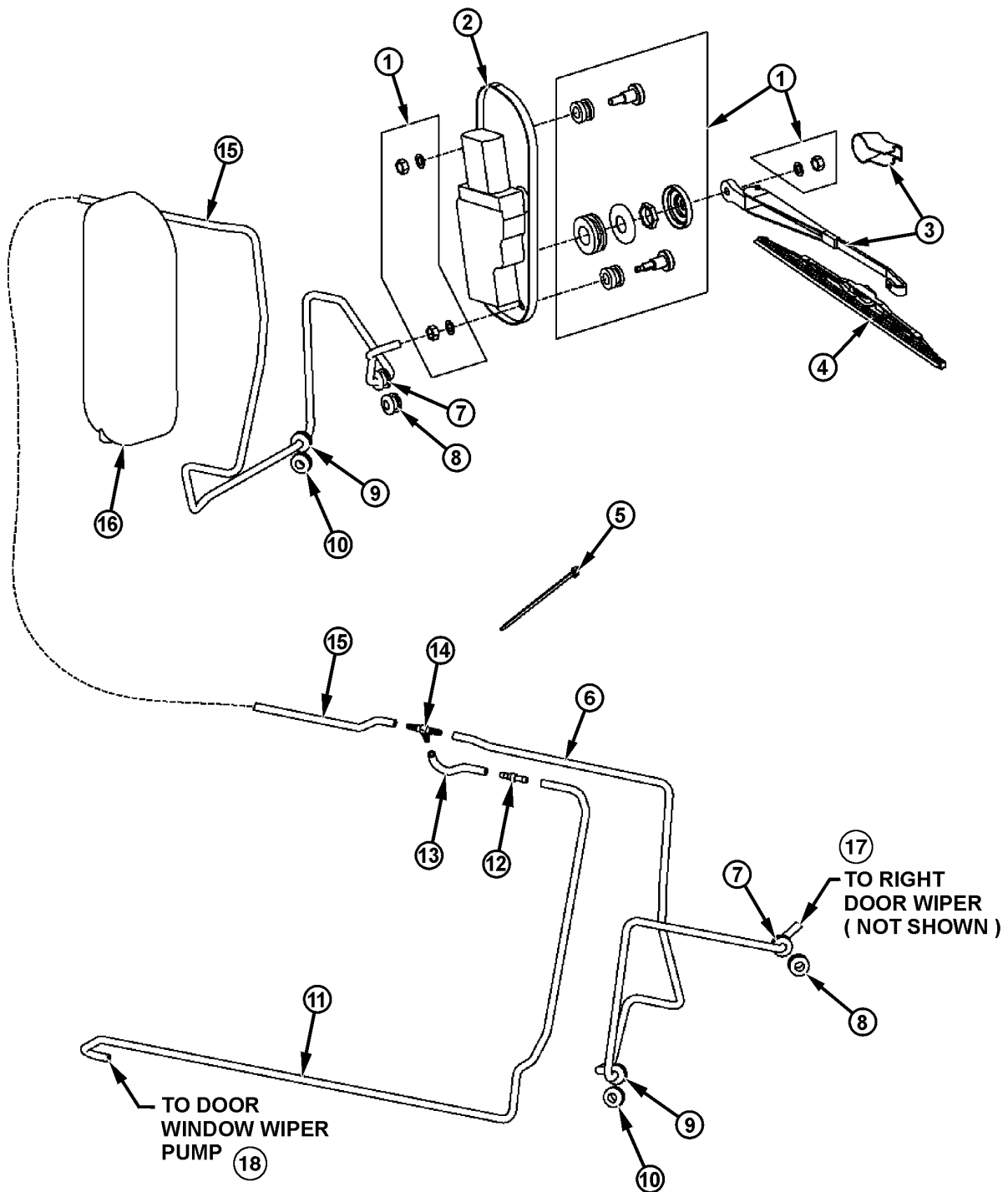

TX1074261

Door Window Wiper (left shown)

TX1074261 —UN—22APR10

Continued on next page

CED, TX03399, 2366 -19-22MAR10-1/2

*Operator's Enclosure*

- |                             |                        |                 |                                     |
|-----------------------------|------------------------|-----------------|-------------------------------------|
| 1— Screw and Washer Kit     | 6— Hose                | 11— Hose        | 16— Wiper Cover                     |
| 2— Wiper Motor (left shown) | 7— Grommet (2 used)    | 12— Valve       | 17— To Right Door Wiper (not shown) |
| 3— Wiper Arm (2 used)       | 8— Grommet (2 used)    | 13— Hose        | 18— To Door Window Wiper Pump       |
| 4— Wiper Blade (2 used)     | 9— Grommet (2 used)    | 14— Tee Fitting |                                     |
| 5— Tie Band (as required)   | 10— Windowpane Grommet | 15— Hose        |                                     |

CED, TX03399,2366 -19-22MAR10-2/2

### Rear Window Wiper Remove and Install

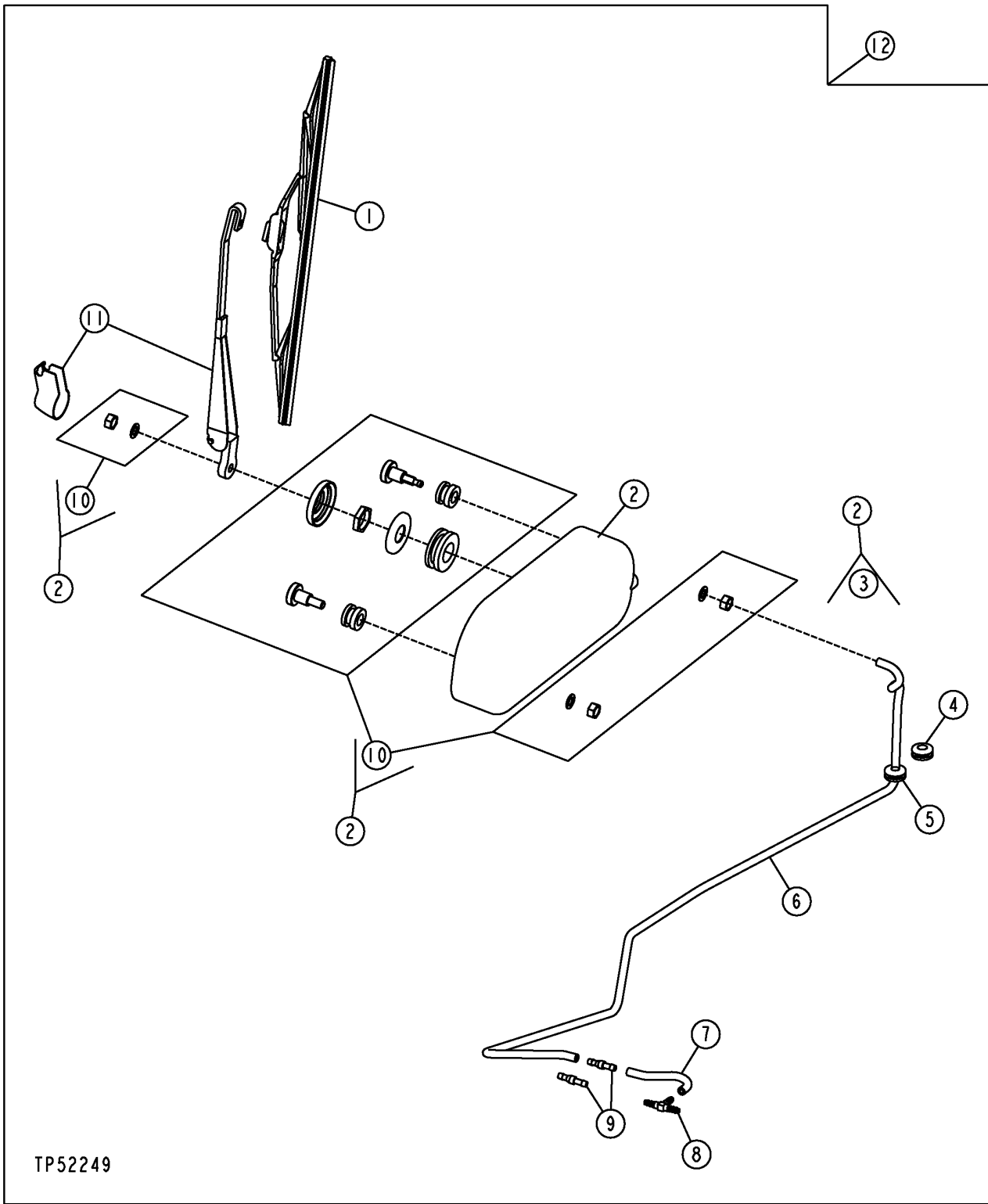

TP52249

TP52249 —UN—18MAY99

Continued on next page

MF82180,00001D9 -19-06MAY04-1/2

## Operator's Enclosure

1— Wiper Blade  
2— Wiper Motor  
3— Cover

4— Grommet  
5— Grommet  
6— Hose

7— Hose  
8— Tee Fitting  
9— Flow Control Valve

10— Hardware  
11— Wiper Arm

MF82180,00001D9 -19-06MAY04-2/2

### Window Washer Pumps Remove and Install

1. Drain window washer reservoir (5).
2. Disconnect window washer pump inlet (1) and outlet hose (2).
3. Disconnect window washer pump harness (6).
4. Remove window washer pump (3).
5. Install window washer pump.
6. Connect window washer pump inlet and outlet hoses.
7. Connect window washer pump harness.
8. Fill window washer reservoir (5).

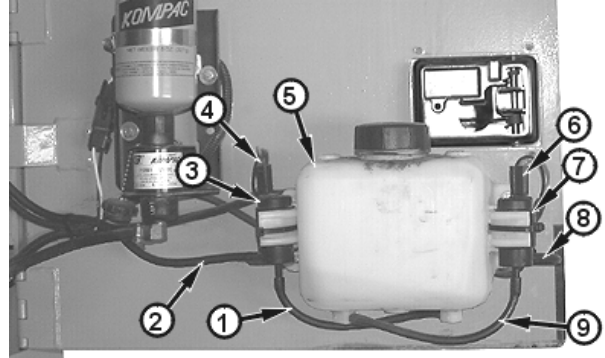

T121000B—UN—09APR99

- |   |   |
|---|---|
| <p>1— Hose (Window Washer Reservoir to Front/Rear Window Washer Pump Inlet)</p> <p>2— Hose (Washer Pump Outlet-to-Front/Rear Windows)</p> <p>3— Front/Rear Window Washer Pump</p> <p>4— Front/Rear Window Washer Pump Harness</p> <p>5— Window Washer Reservoir</p> | <p>6— Left/Right Door Window Washer Pump Harness</p> <p>7— Left/Right Door Window Washer Pump</p> <p>8— Hose (Washer Pump Outlet-to-Right/Left Door Windows)</p> <p>9— Hose (Window Washer Reservoir to Left/Right Door Window Washer Pump Inlet)</p> |
|---|---|

CED,OUO1066,302 -19-23MAR01-1/1

*Operator's Enclosure*

Standard Seat Remove and Install (Old)

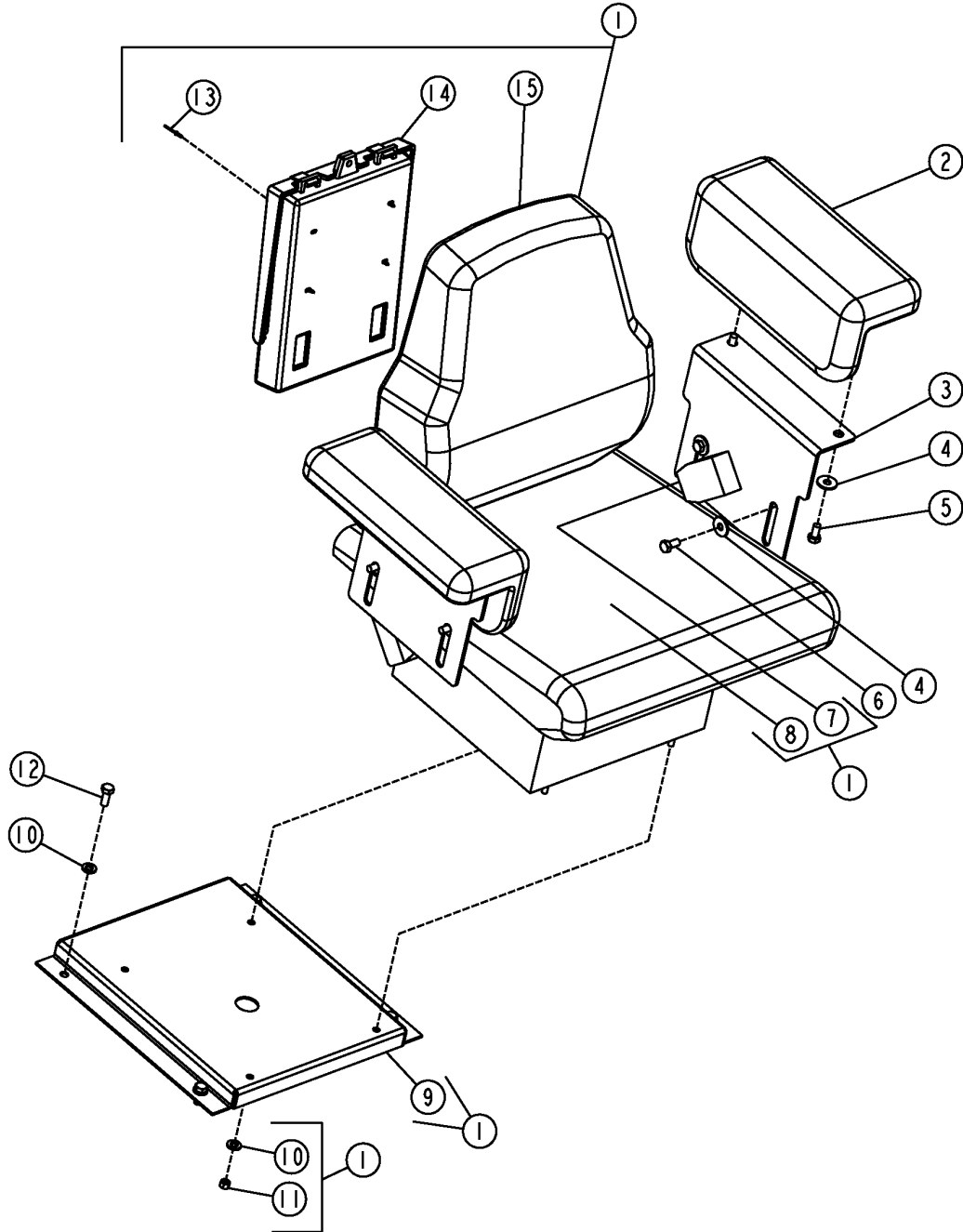

TP52109

Continued on next page

CED,OUTX547,168 -19-17MAR06-1/5

TP52109—UN—16/JAN99

## Seat and Seat Belt

- |                                      |                       |                        |                    |
|--------------------------------------|-----------------------|------------------------|--------------------|
| 1— Standard Seat Suspension Assembly | 5— Cap Screw (4 used) | 9— Bracket             | 13— Rivet (4 used) |
| 2— Armrest (2 used)                  | 6— Cap Screw (4 used) | 10— Washer (8 used)    | 14— Holder         |
| 3— Armrest Bracket (2 used)          | 7— Seat Belt          | 11— Lock Nut (4 used)  | 15— Back Pad       |
| 4— Washer (8 used)                   | 8— Seat Pad           | 12— Cap Screw (4 used) |                    |

**⚠ CAUTION:** Prevent possible crushing injury from seat suspension. Use proper lifting equipment and safety precautions.

1. Remove parts as necessary.
2. Install parts as necessary.

CED,OUTX547,168 -19-17MAR06-2/5

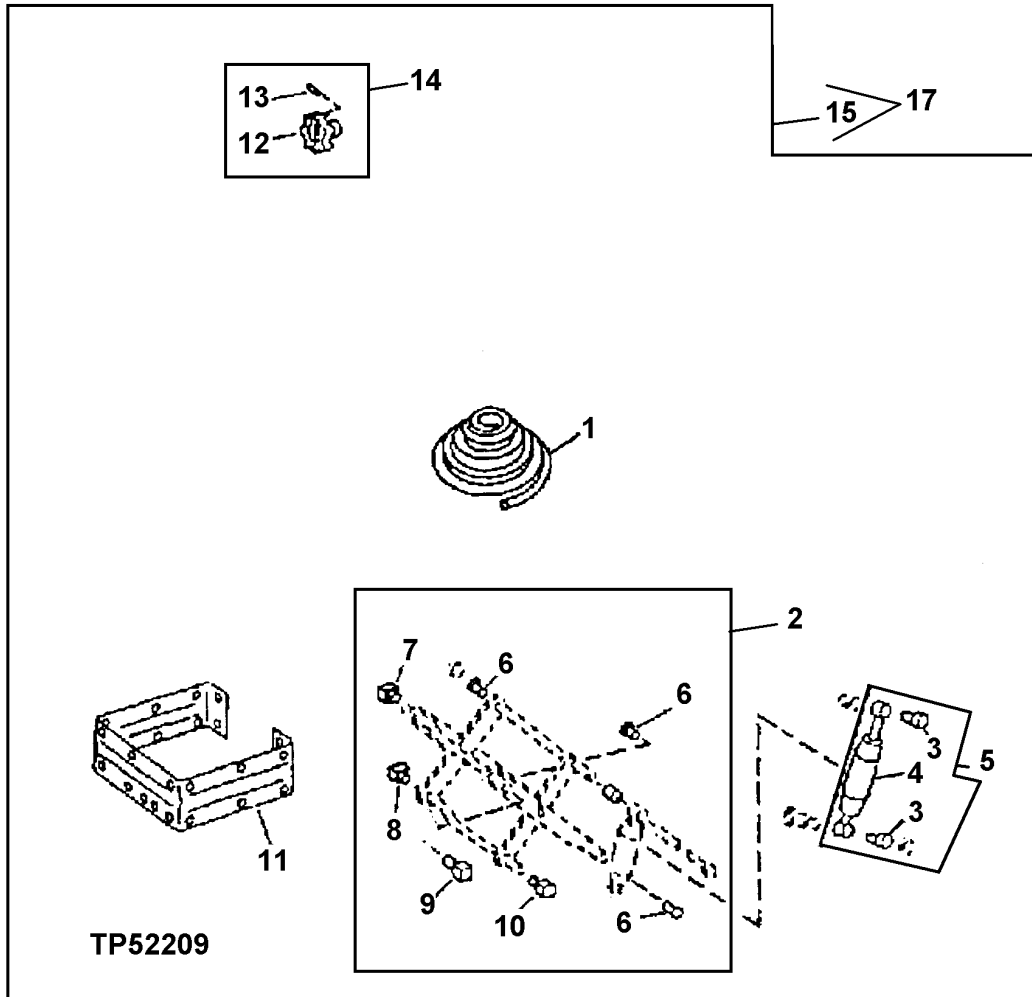

**TP52209**

### Standard Seat Suspension

- |                           |                       |                     |   |
|---------------------------|-----------------------|---------------------|---|
| 1— Spring                 | 5— Shock Absorber Kit | 9— Bar              | 13— Spring Pin                            |
| 2— Suspension Bearing Kit | 6— Bushing (4 used)   | 10— Bar             | 14— Height and Weight Adjustable Knob Kit |
| 3— Bushing (2 used)       | 7— Bar                | 11— Boot with Plugs | 15— Guard Suspension Assembly             |
| 4— Absorber               | 8— Bar                | 12— Knob            | 17— Standard Seat Suspension Assembly     |

Continued on next page

CED,OUTX547,168 -19-17MAR06-3/5

TP52209 —UN—14JAN99

Seat and Seat Belt

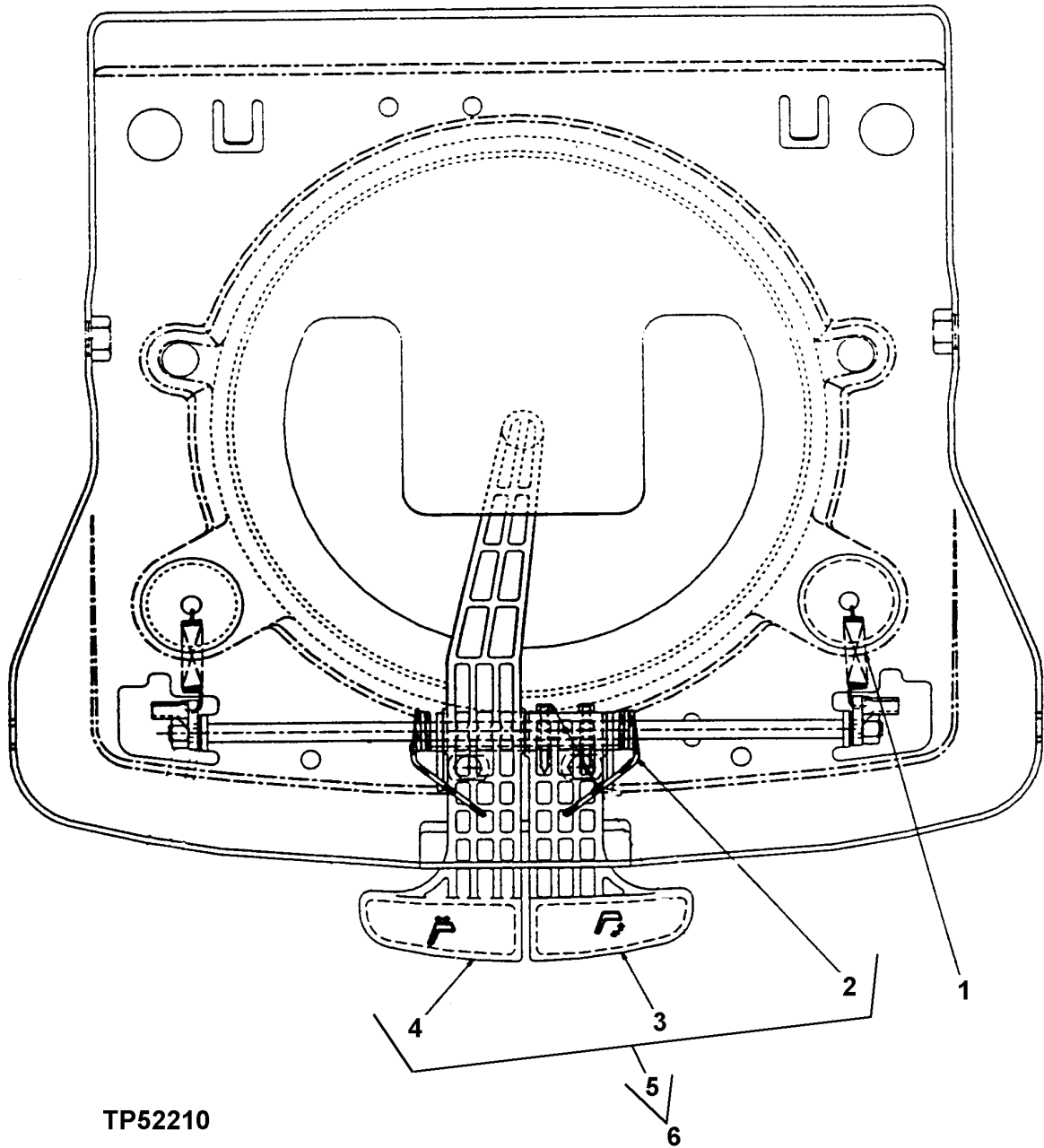

TP52210

Seat Slide and Tilt Control (Standard or Deluxe Seat)

1— Spring (2 used)  
2— Torsion Spring

3— Seat Tilt Control  
4— Fore-Aft Control

5— Slide/Seat Tilt Control Kit  
6— Standard or Deluxe Seat  
Suspension Assembly

Continued on next page

CED,OUTX547,168 -19-17MAR06-4/5

TP52210—UN—14JAN99

Seat and Seat Belt

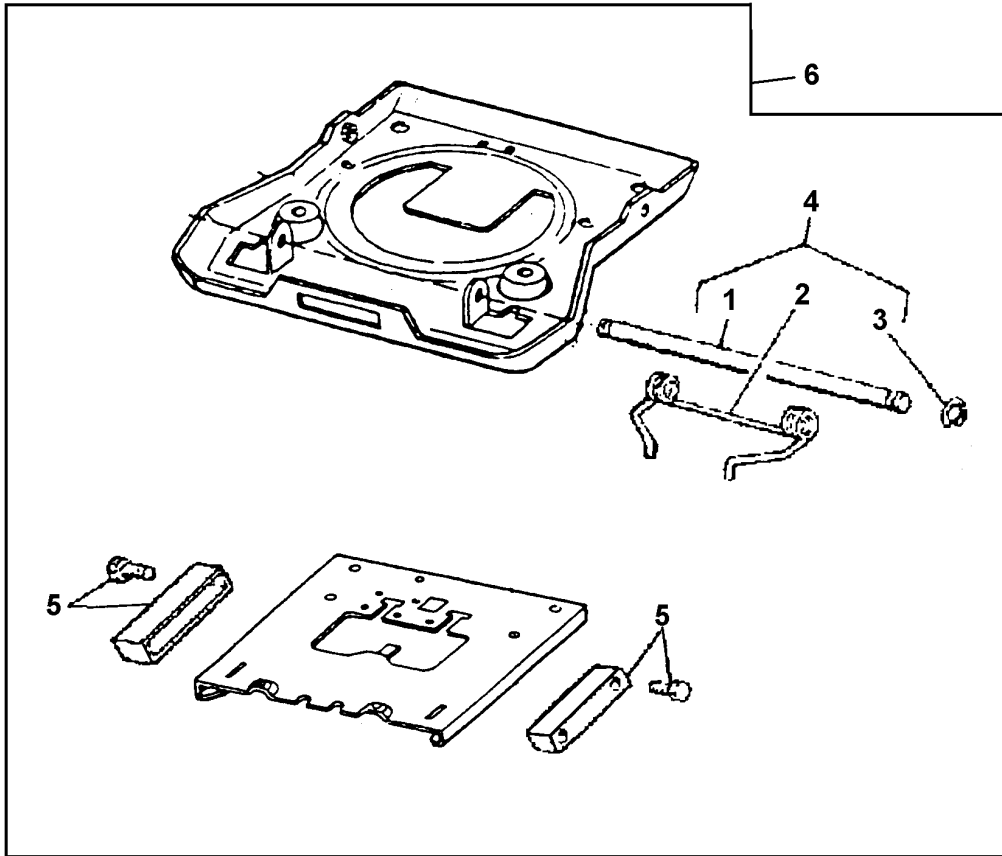

TP52211

Seat Slide Spring (Standard or Deluxe Seat)

1— Shaft  
2— Spring

3— Snap Ring  
4— Slide Latch Spring Kit

5— Slide Puck Kit  
6— Standard or Deluxe Seat  
Suspension Assembly

CED,OUTX547,168 -19-17MAR06-5/5

TP52211 —UN—14JAN99

**Deluxe Seat Remove and Install**

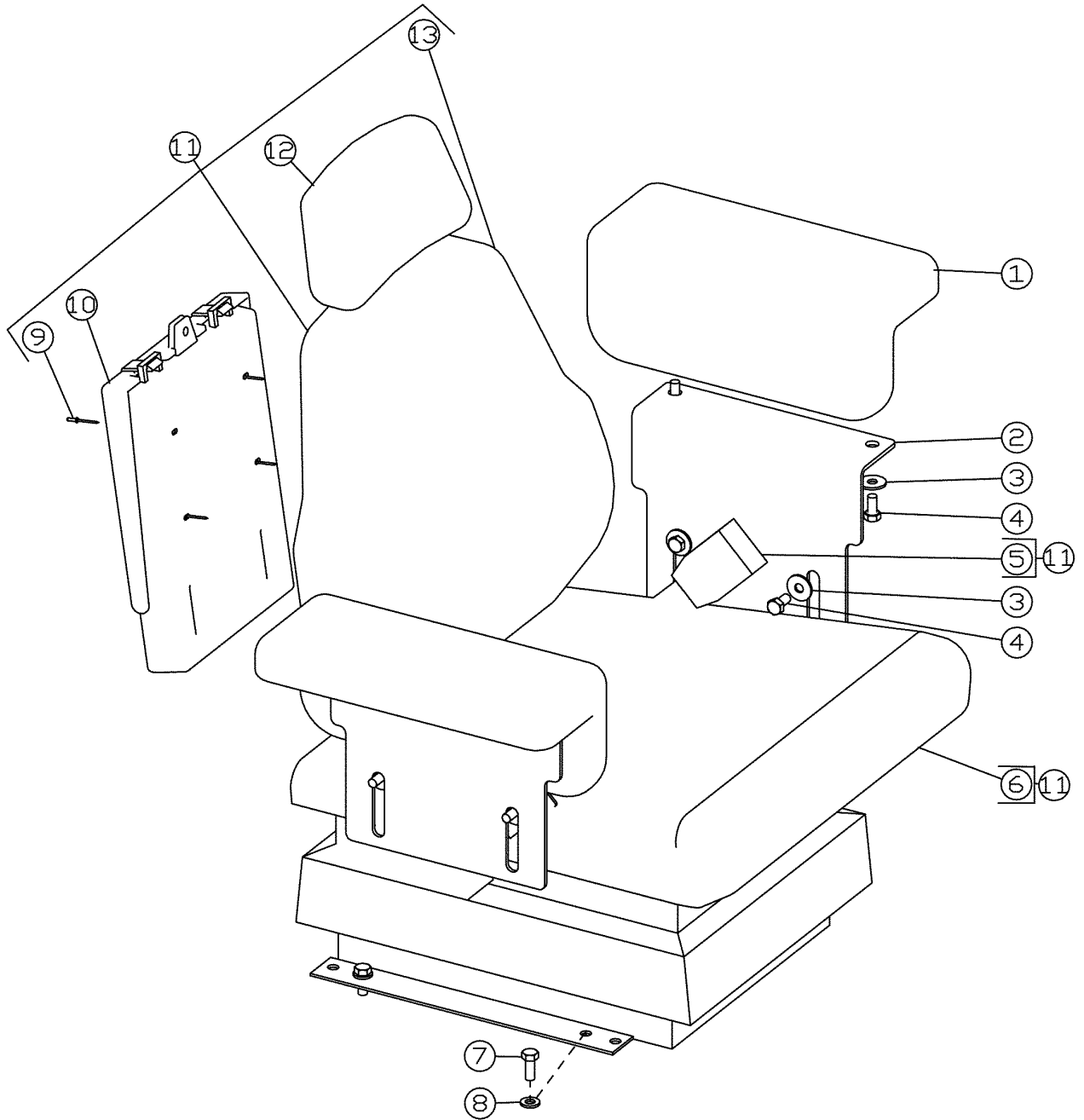

T119920

*Deluxe Seat Suspension*

Continued on next page

CED,OUO1066,274 -19-29JUL09-1/10

T119920 —UN—27JAN99

*Seat and Seat Belt*

1— Armrest (2 used)  
2— Armrest Bracket (2 used)  
3— Washer (8 used)  
4— Cap Screw (8 used)

5— Seat Belt  
6— Seat Pad  
7— Cap Screw (4 used)  
8— Washer (4 used)

9— Rivet (As Required)  
10— Holder  
11— Deluxe Seat Suspension  
Assembly  
12— Cushion

13— Back Pad

 **CAUTION: Prevent possible crushing injury from seat suspension. Use proper lifting equipment and safety precautions.**

1. Remove parts as necessary.
2. Install parts as necessary.

Continued on next page

CED,OUO1066,274 -19-29JUL09-2/10

Seat and Seat Belt

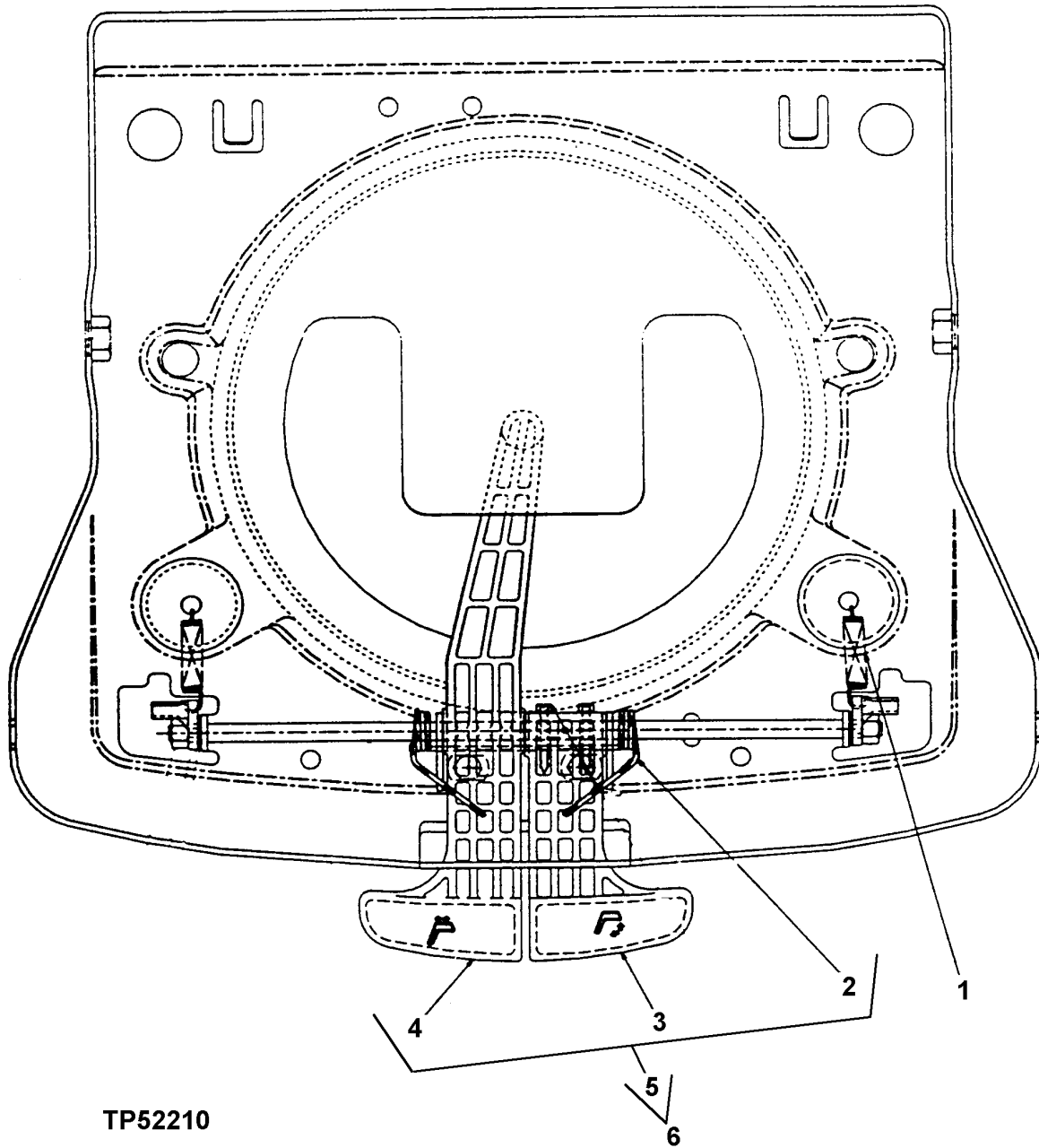

TP52210

Seat Slide and Tilt Control (Standard or Deluxe Seat)

1— Spring (2 used)  
2— Torsion Spring

3— Seat Tilt Control  
4— Fore-Aft Control

5— Slide/Seat Tilt Control Kit  
6— Standard or Deluxe Seat  
Suspension Assembly

Continued on next page

CED,OUO1066,274 -19-29JUL09-3/10

TP52210 — UN — 14/JAN99

Seat and Seat Belt

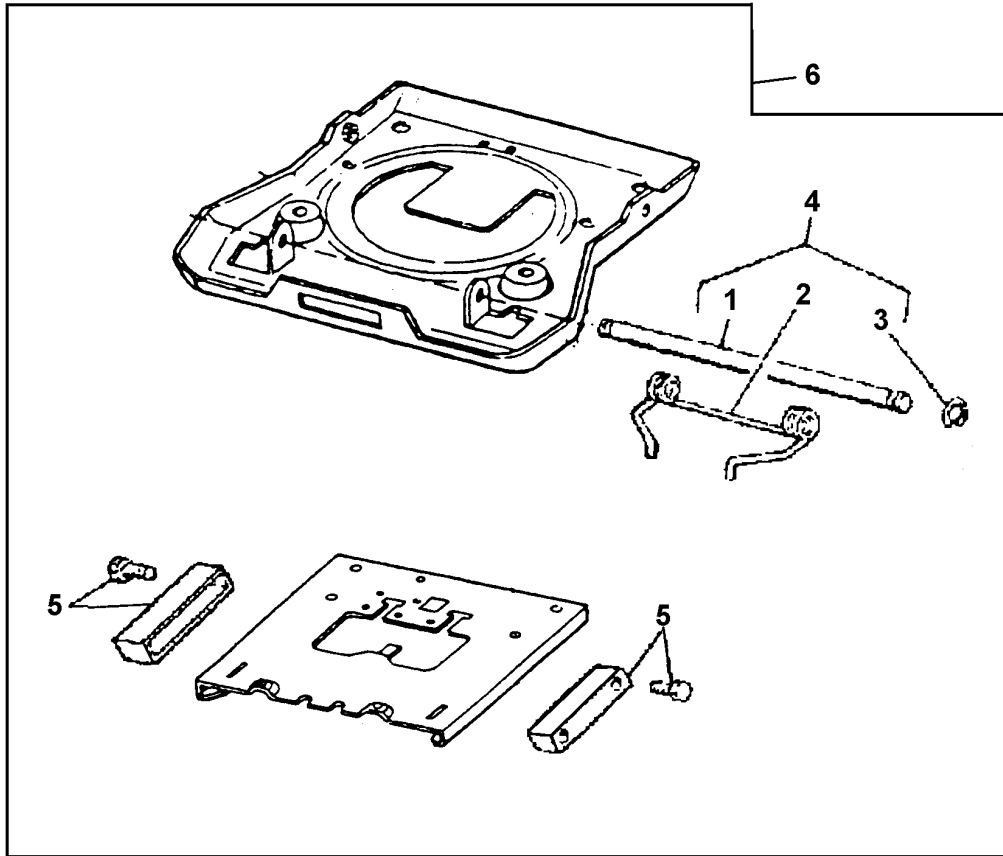

TP52211

Seat Slide Spring (Standard or Deluxe Seat)

1— Shaft  
2— Spring

3— Snap Ring  
4— Slide Latch Spring Kit

5— Slide Puck Kit  
6— Standard or Deluxe Seat  
Suspension Assembly

Continued on next page

CED,OUO1066,274 -19-29JUL09-4/10

TP52211 —UN—14JAN99

Seat and Seat Belt

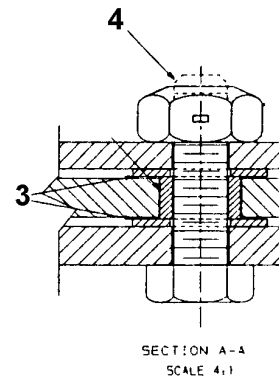
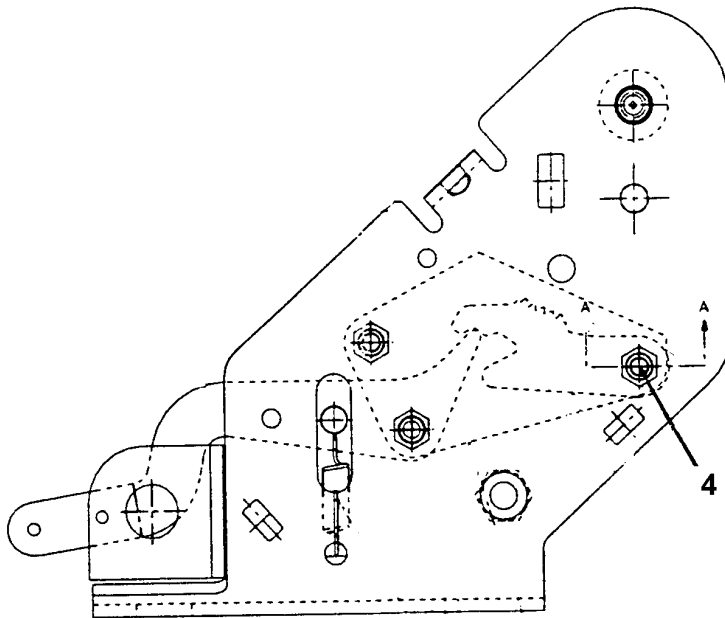
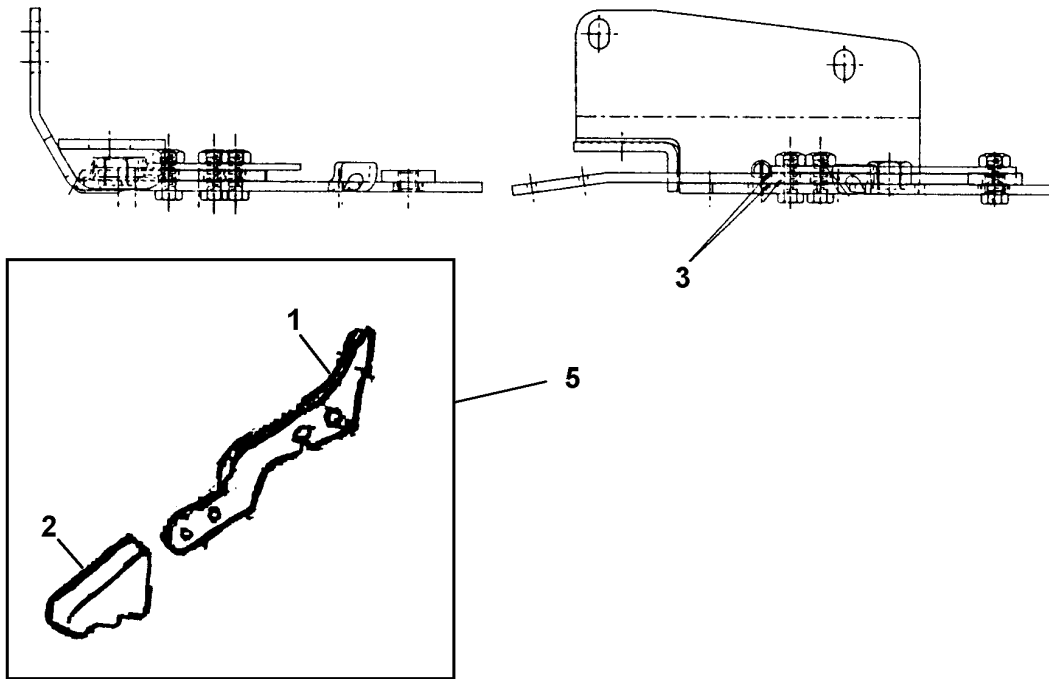

**TP52212**

*Recliner/Lumbar Knob Kit (Deluxe Seat)*

- 1— Recliner Kit
- 2— Recliner Kit and Screw

- 3— Washer (6 used)
- 4— Cap Screw (3 used)

- 5— Deluxe Seat Suspension Assembly

Continued on next page

CED,OUO1066,274 -19-29JUL09-5/10

TP52212 —UN—14JAN99

Seat and Seat Belt

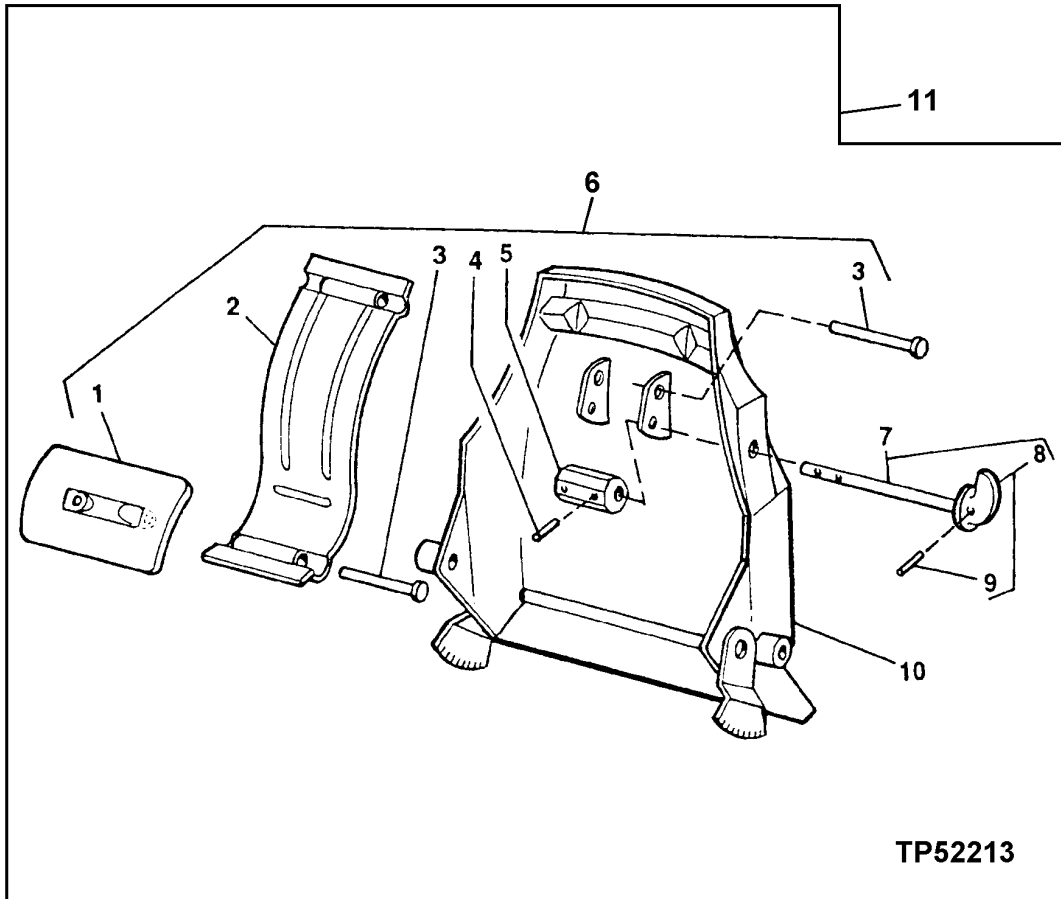

TP52213

Lumbar Support and Control (Deluxe Seat)

1— Isolator  
2— Support  
3— Pin (2 used)

4— Spring Pin  
5— Cam  
6— Lumbar Kit

7— Knob with Shaft  
8— Lumbar Knob Kit  
9— Spring Pin

10— Seat Back  
11— Deluxe Seat Suspension  
Assembly

Continued on next page

CED.OUO1066,274 -19-29JUL09-6/10

TP52213 — UN—14JAN99

Seat and Seat Belt

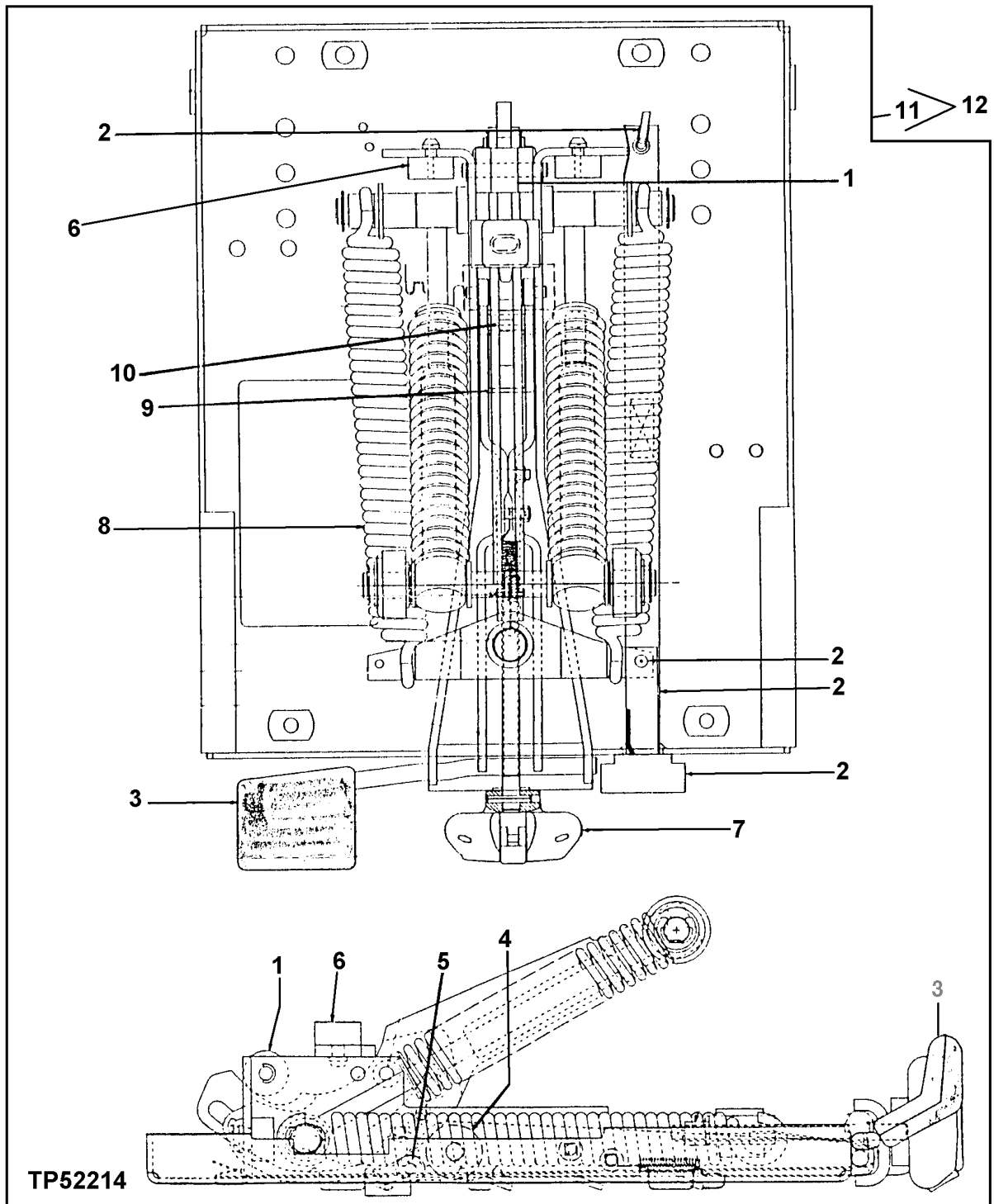

TP52214

TP52214 —UN—14 JAN99

Seat Suspension Kits (Deluxe Seat)

- |  |  |  |  |
|--|--|--|--|
| 1— Cam Kit—Cam Follower and Pin                    | 4— Cam Kit—Cam Follower and Pin                      | 7— Weight Adjust Knob Kit—Knob, Fixture, Spacer, Shaft | 10— Actuator Kit—Idler Roller (2 used), Cam Roller |
| 2— Weight Kit—Tape, Guide, Cable Tie and Pop Rivet | 5— Actuator Kit—Idler roller (2 used) and cam roller | 8— Spring Kit—Bushings (2 used) and Springs (2 used)   | 11— Seat Suspension Sub-Assembly                   |
| 3— Knob Kit—Height Adjust Knob Upper and Lower     | 6— Bumper Kit—Bumpers (3 used)                       | 9— Cam Kit—Cam Follower, Pin                           | 12— Deluxe Seat Suspension                         |

Continued on next page

CED,OUO1066,274 -19-29JUL09-7/10

Seat and Seat Belt

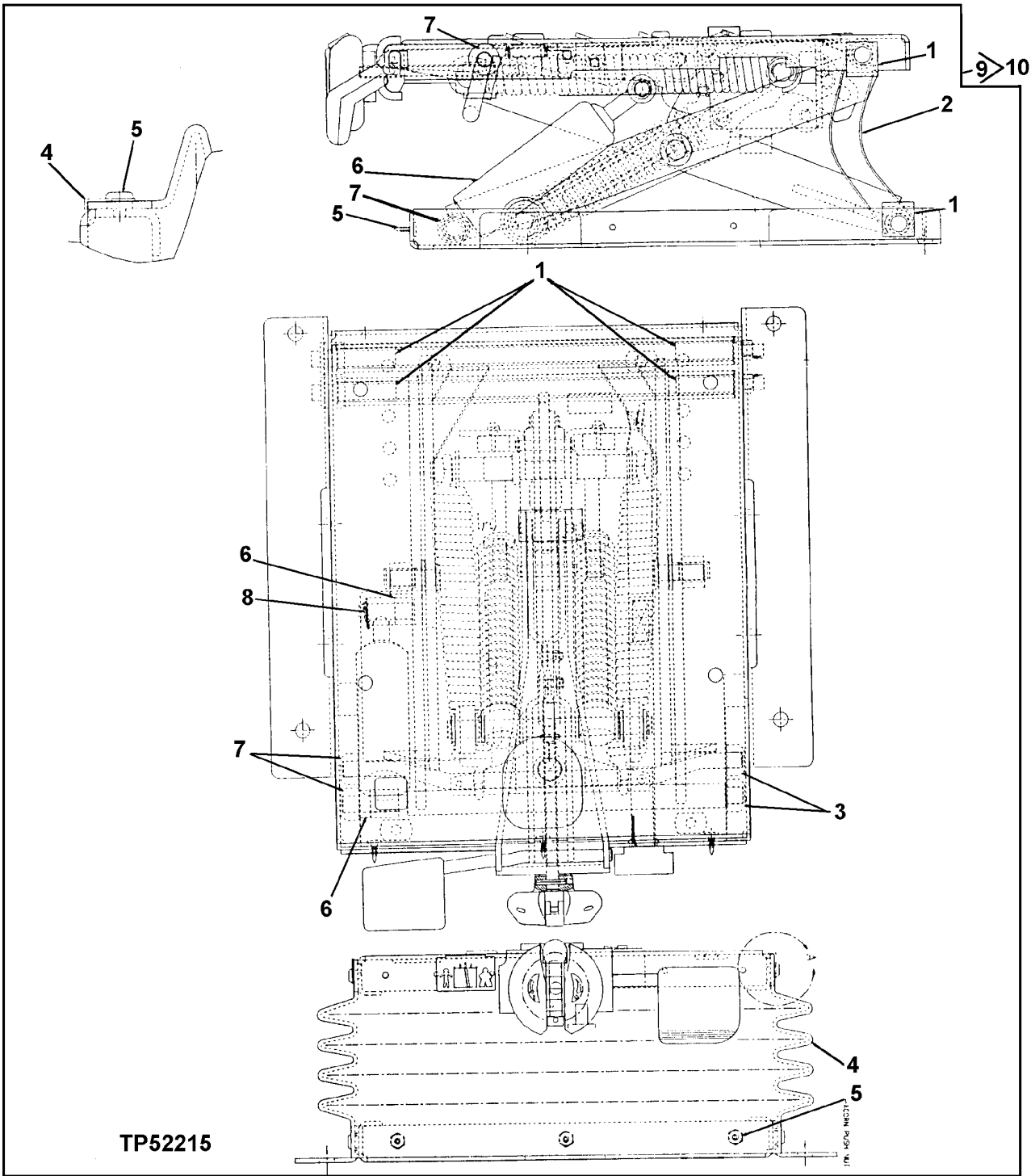

Seat Suspension Kits (Deluxe Seat)

TP52215 — UN — 14 JAN 99

Continued on next page

CED, OOU1066, 274 -19-29 JUL 09-8/10

*Seat and Seat Belt*

- |  |  |  |                            |
|--|--|--|----------------------------|
| 1— Universal Driveshaft Kit—Bearings (4 used), Bearing Shaft Weldment (2 used) | 4— Boot Kit—Clip (23 used), Male Fastener (3 used), Female Fastener (3 used), Boot, Boot Retainer (2 used) | 7— Roller Kit—Roller (4 used)  | 10— Deluxe Seat Suspension |
| 2— Tether Belt Kit—Tether Belt (2 used)  | 5— Boot Clip Kit—Clip (23 used), Male Fastener (3 used), Female Fastener (3 used)                          | 8— Height Adjust Kit—Spring Bushing (2 used), Spring (2 used), Retainer ring (4 used), Push Nut (2 used) |                            |
| 3— Roller Kit—Roller (4 used)  | 6— Shock Kit—Push Nut, Shock, Bearing (2 used)   | 9— Deluxe Seat Sub-Assembly  |                            |

Continued on next page

CED,OUO1066,274 -19-29JUL09-9/10

Seat and Seat Belt

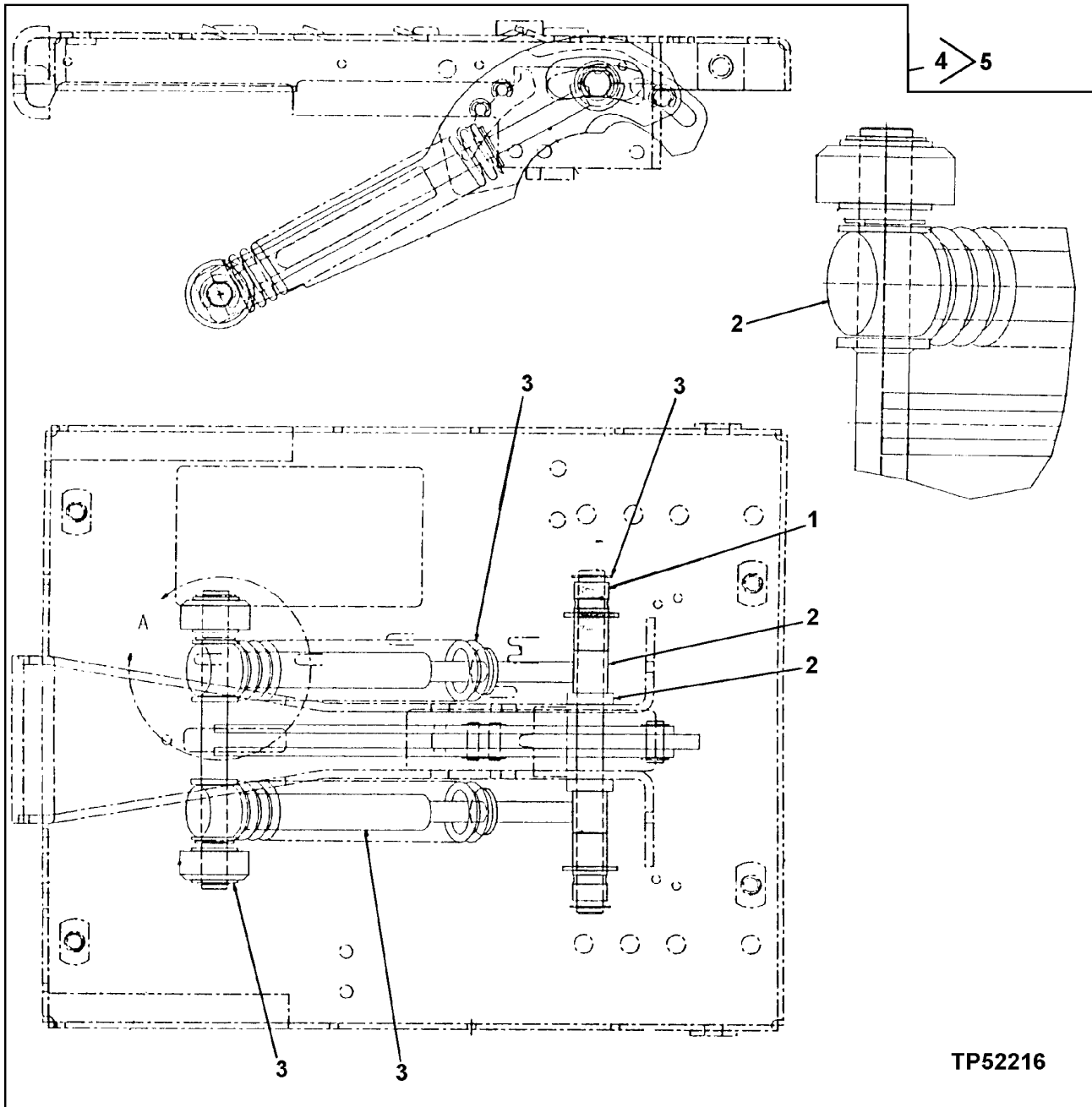

TP52216

TP52216—UN—14JAN99

Seat Suspension Kits (Deluxe Seat)

- |   |   |                           |
|---|---|---------------------------|
| 1— Spring Kit—Spring Shaft<br>Bushing (2 used), Spring (2<br>used)  | 3— Height Adjust Kit—Bushing<br>(4 used), Spring (4 used),<br>Retainer Ring (4 used), Push<br>Nut (2 used), Spacer (2 used),<br>Spring Rod Weldment (2<br>used) | 5— Deluxe Suspension Seat |
| 2— Spring Kit—Height Adjust<br>Spring Rod Weldment (2<br>used), Spring Guide Bushing<br>(2 used), Spring (2 used),<br>Spacer (2 used) | 4— Deluxe Sub-Assembly  |                           |

CED,OUO1066,274 -19-29JUL09-10/10

### Air Suspension Seat Remove and Install

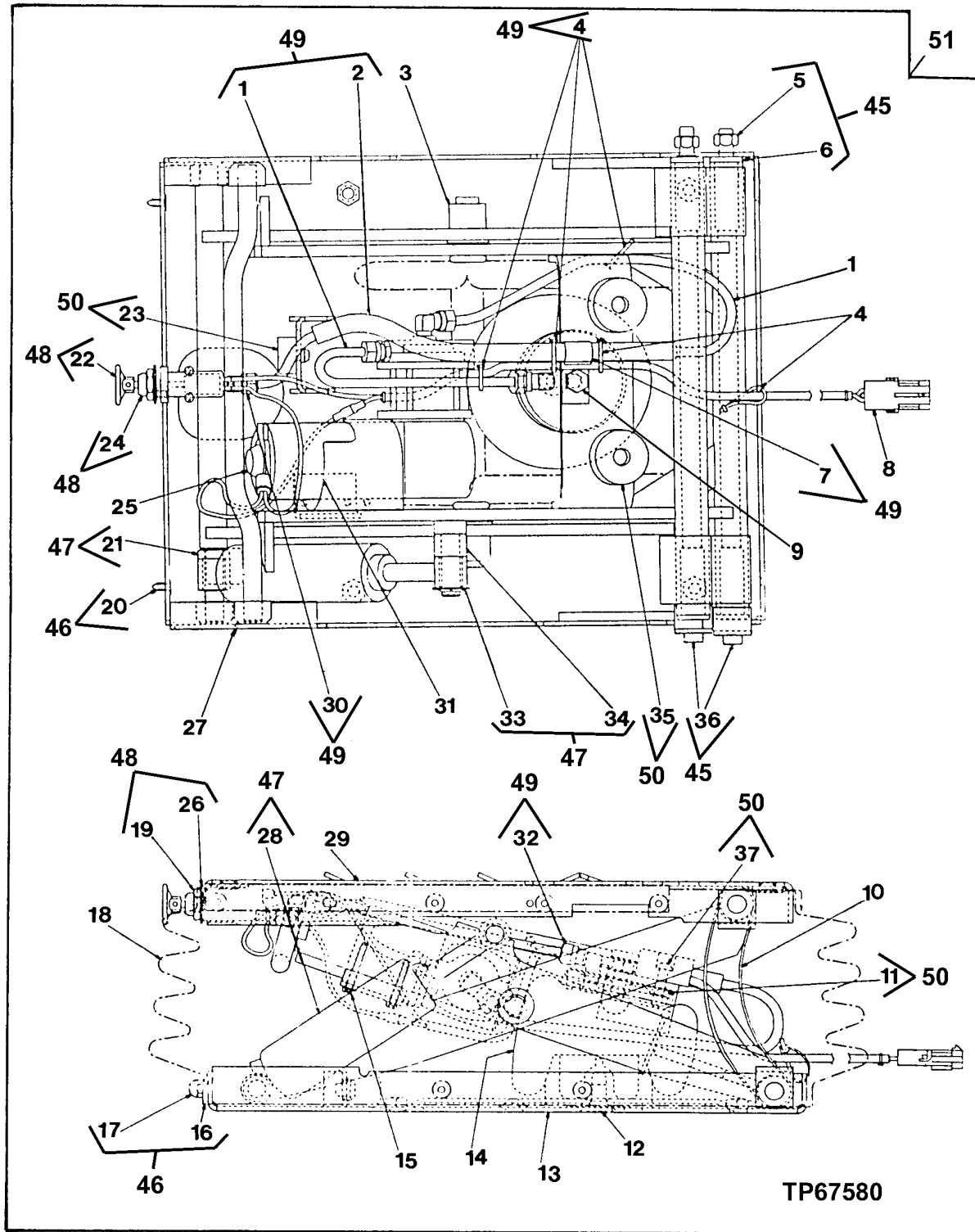

Seat Suspension Kits (deluxe air seat)

Continued on next page

CED, TX03399, 6055 -19-04DEC09-1/2

TP67580—UN—19AUG99

## Seat and Seat Belt

1— Line (3 used)	12— Screw	23— Bumper	34— Bearing
2— Air Line Tube	13— Housing	24— Control Valve	35— Bumper
3— Arm	14— Spring	25— Compressor	36— Bearing (2 used)
4— Tie Band (5 used)	15— Screw (2 used)	26— Lock Washer	37— Screw
5— Lock Nut (2 used)	16— Clip (23 used)	27— Roller	45— Universal Suspension Driveshaft
6— Suspension Shaft (2 used)	17— Push Nut (3 used)	28— Absorber	46— Boot Clip
7— Clip	18— Boot Kit	29— Housing	47— Shock Absorber Kit
8— Wire Harness	19— Nut	30— Connector (2 used)	48— Air Control Valve
9— Cap Screw	20— Clip (3 used)	31— Bracket	49— Air Line Fitting
10— Tether Belt Kit	21— Bearing	32— Elbow Fitting (2 used)	50— Bumper
11— Lock Nut	22— Knob	33— Bolt	51— Seat and Air Suspension Assembly

 **CAUTION: Prevent possible crushing injury from seat suspension. Use proper lifting equipment and safety precautions.**

1. Remove parts as necessary.
2. Install parts as necessary.

CED, TX03399, 6055 -19-04DEC09-2/2

**R134a Refrigerant Cautions**

**⚠ CAUTION: DO NOT** allow liquid refrigerant to contact eyes or skin. Liquid refrigerant will freeze eyes or skin on contact. Wear goggles, gloves and protective clothing.

If liquid refrigerant contacts eyes or skin, **DO NOT** rub the area. Splash large amounts of **COOL** water on affected area. Go to a physician or hospital immediately for treatment.

**DO NOT** allow refrigerant to contact open flames or very hot surfaces such as electric welding arc, electric heating element and lighted smoking materials.

**DO NOT** heat refrigerant over 52°C (125°F) in a closed container. Heated refrigerant will develop high pressure which can burst the container.

Keep refrigerant containers away from heat sources. Store refrigerant in a cool place.

**DO NOT** handle damp refrigerant container with your bare hands. Skin may freeze to container. Wear gloves.

If skin freezes to container, pour **COOL** water over container to free the skin. Go to a physician or hospital immediately for treatment.

CED,OUTX547,172 -19-21OCT98-1/1

**R134a Compressor Oil Charge Check**

Remove compressor if R134a leakage was detected and repaired. See Compressor Remove and Install . (Group 1830.)

Drain oil from the compressor and record the amount. See R134a Compressor Oil Removal. (Group 1830.)

*NOTE: Drain oil and save if this is a new compressor.*

If the oil drained from a compressor removed from operation is very black or the amount of oil is less than specification, perform the following:

**Specification**

Compressor	
Oil—Volume.....	6.0 mL 0.2 fl oz

1. Remove and discard the receiver-dryer.

2. Remove, clean, but do not disassemble the valve.
3. Flush the complete system with TY16134 air conditioning flushing solvent.
4. If the compressor is serviceable, pour flushing solvent in the manifold ports and internally wash out the old oil.
5. Install a new receiver-dryer.
6. Install required amount of TY22025 refrigerant oil in the compressor. See R134a Component Oil Charge. (Group 1830.)
7. Connect all components, evacuate and charge the system.

CED,OUTX547,173 -19-05MAY04-1/1

**R134a Compressor Oil Removal**

1. Remove compressor from machine. See Compressor Remove and Install. (Group 1830.)
2. Remove inlet/outlet manifold from compressor, and clutch dust cover.
3. Drain oil into graduated container while rotating compressor shaft.

4. Record measured oil and discard oil properly.
5. Install new oil. See R134a Component Oil Charge. (Group 1830.)
6. Install compressor. See Compressor Remove and Install. (Group 1830.)

CED,OUTX547,174 -19-05MAY04-1/1

## R134a Component Oil Charge

**CAUTION:** All new compressors are charged with a mixture of nitrogen, R134a refrigerant and TY22025 (R134a) refrigerant oil. Wear safety goggles and discharge the compressor slowly to avoid possible injury.

Compressors can be divided into three categories when determining the correct oil charge for the system.

- New compressor from parts depot
- Used compressor removed from operation
- Compressor internally washed with flushing solvent

**Use the following procedure to determine the amount of system oil charge prior to installation of compressor on a machine.**

1. When the complete system, lines, and components were flushed add the correct amount of oil as described.

- New compressor from parts depot contains a amount of new oil. System requires an additional amount of new oil.

**Specification**

Oil, New Compressor Installation, Complete System Flushed—Supplied Volume.....	210—250 mL 7.0—8.4 fl oz
Additional Volume .....	32.5 mL 1.1 fl oz

- Used compressor removed from operation, oil drained, and flushed requires specified amount of new oil.

**Specification**

Oil, Used Compressor Installation, Complete System Flushed—Volume.....	260 mL 8.8 fl oz
---	---------------------

2. When the complete system was not flushed add the correct amount of oil for the compressor plus the amount of oil for each component that was serviced.

- New compressor from parts depot, drain and return specified amount of oil to the compressor. See R134a Compressor Oil Removal. (Group 1830.)

Item	Measurement	Specification
Evaporator	Oil Charge	32.5 mL 1.1 fl oz
Condenser	Oil Charge	32.5 mL 1.1 fl oz
Receiver/Dryer	Oil Charge	30 mL 1.0 fl oz

**Specification**

Oil, New Compressor Installation, Complete System Not Flushed—Volume.....	Drain and return 45 mL Drain and return 1.5 fl oz
--	--

- Used compressor removed from operation and oil drained. See R134a Compressor Oil Removal. (Group 1830.) Add specified amount of new oil.

**Specification**

Oil, Used Compressor Installation, Complete System Not Flushed, Oil Drained—Volume.....	Add 45 mL Add 1.5 fl oz
--	----------------------------

- Used compressor removed from operation, oil drained, and flushed add specified amount of new oil.

**Specification**

Oil, Used Compressor Installation, Complete System Not Flushed, Oil Drained, Flushed—Volume.....	Add 60 mL Add 2.0 fl oz
--	----------------------------

**NOTE:** Hoses = 3 mL per 0.3 m (0.1 fl oz per ft).  
Approximate total length equals 12.5 m (41.0 ft).

3. If any section of hose is removed and flushed or replaced, measure the length of hose and use the formula to determine the correct amount of oil to be added.

**CAUTION:** DO NOT leave the system or R134a compressor oil containers open. This oil easily absorbs moisture. DO NOT spill R134a compressor oil on acrylic or ABS plastic. This oil will deteriorate these materials rapidly. Identify R134a oil containers and measures to eliminate accidental mixing of different oils.

Components listed below which have been removed, drained or flushed, require the removal of the compressor to determine the correct oil charge. Use the following chart as a guide for adding oil to components:

Item	Measurement	Specification
Hoses	Oil Charge	121.2 mL approximate 4.1 fl oz approximate

CED,OUTX547,175 -19-05MAY04-2/2

### Leakage Testing

1. Inspect all lines, fittings, and components for oily or dusty spots. When refrigerant leaks from the system, a small amount of oil is carried out with it.
2. A soap and water solution can be sprayed on the components in the system to form bubbles at the source of the leak.
3. If a leak detector is used, move the leak detector probe under the hoses and around the connections at specified rate.
4. Some refrigerant manufacturers add dye to refrigerant to aid in leak detection.

CED,OUO1066,309 -19-05MAY04-1/1

### R134a Refrigerant Recovery, Recycling and Charging Station Installation Procedure

**⚠ CAUTION:** Do not remove high pressure relief valve (A). Air conditioning system will discharge rapidly causing possible injury.

**IMPORTANT:** Use correct refrigerant recovery, recycling and charging stations. **DO NOT** mix refrigerant, hoses, fittings, components or refrigerant oils.

1. Close both high and low pressure valves on refrigerant recovery, recycling and charging station (H).
2. Remove cap from low pressure test port (G).
3. Connect low pressure blue hose (D) from refrigerant recovery, recycling and charging station (H) to low pressure test port (G) on compressor.
4. Connect high pressure red hose (C) to high pressure quick disconnect (B).
5. Follow the manufacturers instructions when using the refrigerant recovery, recycling and charging station.

- |                              |   |
|------------------------------|---|
| A—High Pressure Relief Valve | E—High Pressure Hose                                  |
| B—High Pressure Test Port    | F—Low Pressure Hose                                   |
| C—Red Hose                   | G—Low Pressure Test Port                              |
| D—Blue Hose                  | H—Refrigerant Recovery/Recycling and Charging Station |

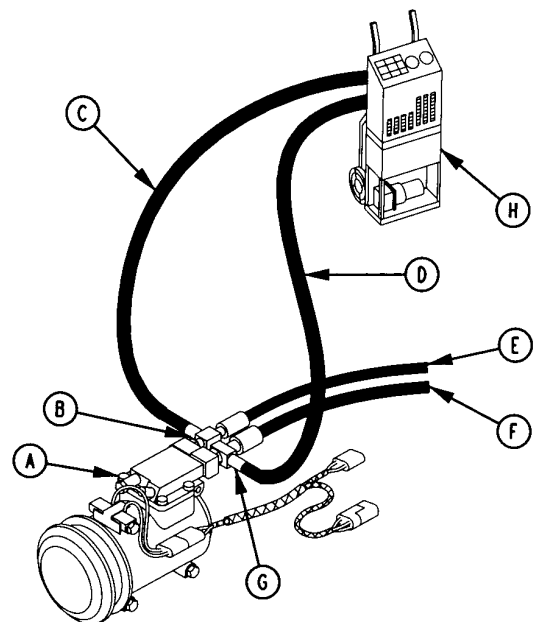

TX1073899 (CV)

R134a Refrigerant Recovery, Recycling and Charging Station

TX1073899 —UN—24MAR10

CED,OUTX547,176 -19-22MAR10-1/1

## Recover R134a System

**CAUTION:** Do not remove high pressure relief valve (A). Air conditioning system will discharge rapidly causing possible injury.

**IMPORTANT:** Use correct refrigerant recovery, recycling and charging stations. **DO NOT** mix refrigerant, hoses, fittings, components or refrigerant oils.

**NOTE:** Run the air conditioning system for three minutes to help in the recovery process. Turn air conditioning system off before proceeding with recovery steps.

1. Connect refrigerant recovery, recycling and charging station. See R134a Refrigerant Recovery, Recycling and Charging Station Installation Procedure. (Group 1830.)
2. Follow the manufacturers instructions when using the refrigerant recovery, recycling and charging station.

A—High Pressure Relief Valve	E—High Pressure Hose
B—High Pressure Test Port	F—Low Pressure Hose
C—Red Hose	G—Low Pressure Test Port
D—Blue Hose	H—Refrigerant Recovery/Recycling and Charging Station

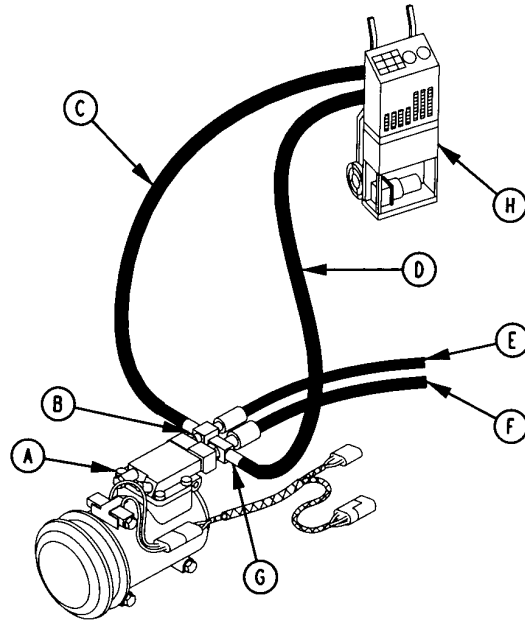

TX1073899 (C)

Recover R134a System

CED.OUTX547,177 -19-22MAR10-1/1

TX1073899 —UN—24MAR10

## Evacuate R134a System

**CAUTION:** Do not remove high pressure relief valve (A). Air conditioning system will discharge rapidly causing possible injury.

**IMPORTANT:** Use correct refrigerant recovery, recycling and charging stations. **DO NOT** mix refrigerant, hoses, fittings, components or refrigerant oils.

**Do not run compressor while evacuating.**

1. Connect refrigerant recovery, recycling and charging station. See R134a Refrigerant Recovery, Recycling and Charging Station Installation Procedure. (Group 1830.)
2. Open low and high pressure valves on refrigerant recovery, recycling and charging station.
3. Follow the manufacturers instructions and evacuate the system.

**NOTE:** The vacuum specifications listed are for sea level conditions. Subtract 3.4 kPa (34 mbar) (1 in. Hg) from 98 kPa (980 mbar) (29 in. Hg) for each 300 m (1000 ft) elevation above sea level.

4. Evacuate system until low pressure gauge registers specified vacuum.

If specified vacuum cannot be obtained in 15 minutes, test the system for leaks. See Leak Testing. (Group 1830.) Correct any leaks.

### Specification

Vacuum—Pressure at	
Sea Level.....	98 kPa 980 mbar 29 in. Hg
Pressure Above Sea	
Level.....	Subtract 3.4 kPa from 98 kPa for each 300 m elevation Subtract 34 mbar from 980 mbar for each 300 m elevation Subtract 1 in. Hg from 29 in. Hg for each 1000 ft elevation

5. When vacuum reaches specified level, close low-side and high-side valves. Turn vacuum pump off.
6. If the vacuum decreases more than specified amount in 5 minutes, there is a leak in the system.

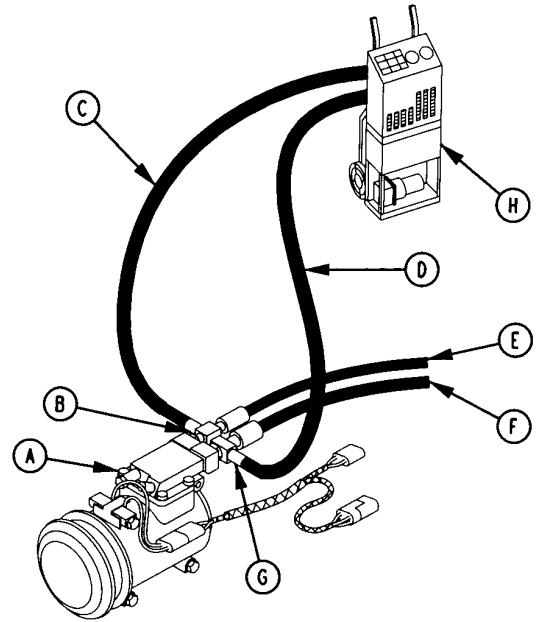

TX1073899 (CV)

A—High Pressure Relief Valve  
B—High Pressure Test Port  
C—Red Hose  
D—Blue Hose

E—High Pressure Hose  
F—Low Pressure Hose  
G—Low Pressure Test Port  
H—Refrigerant Recovery/Recycling and Charging Station

### Specification

Leak Present—Decrease	
in Vacuum.....	3.4 kPa 34 mbar 1 in. Hg

7. Repair leak.
8. Start to evacuate.
9. Open low-side and high-side valves.
10. Evacuate system for 30 minutes after initial specified vacuum is reached.
11. Close low-side and high-side valves. Stop evacuation.
12. See Charge R134a System. (Group 1830.)

CED,OUTX547,178 -19-22MAR10-1/1

TX1073899 —JUN—24MAR10

### Charge R134a System

**CAUTION:** Do not remove high pressure relief valve (A). Air conditioning system will discharge rapidly causing possible injury.

**IMPORTANT:** Use correct refrigerant recovery, recycling and charging stations. **DO NOT** mix refrigerant, hoses, fittings, components or refrigerant oils.

1. Connect JT02045 R134a refrigerant recovery, recycling and charging station. See R134a Refrigerant Recovery, Recycling and Charging Station Installation Procedure. (Group 1830.)
2. Evacuate the system. See Evacuate R134a System. (Group 1830.)

**NOTE:** Before beginning to charge air conditioning system, the following conditions must exist: Engine STOPPED, the pump must be capable of pulling at least 28.6 in. Hg vacuum (sea level). Subtract 3.4 kPa (34 mbar) (1 in. Hg) from 98 kPa (980 mbar) (29 in. Hg) for each 300 m (1000 ft) elevation above sea level.

3. Follow the manufacturers instructions and charge the system.
4. Add refrigerant until system is charged to specification.

**Specification**

Refrigerant—Weight..... 1.6 kg  
 3.5 lbs

5. Perform Air Conditioner Check (Group 9005-10.)

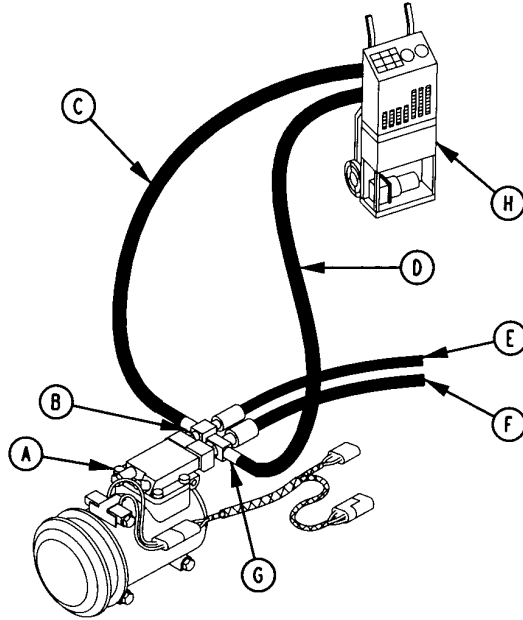

TX1073899 ©

Charge R134a System

- A—High Pressure Relief Valve
- B—High Pressure Test Port
- C—Red Hose
- D—Blue Hose
- E—High Pressure Hose
- F—Low Pressure Hose
- G—Low Pressure Test Port
- H—Refrigerant Recovery/Recycling and Charging Station

TX1073899—UN—24MAR10

CED.OUTX547,179 -19-22MAR10-1/1

## Air Conditioner System Cleaning Procedures

### Flushing

Flushing the system or component is a cleaning process using a liquid solvent to remove oil and debris. Purging is always necessary after flushing to remove solvent from the system or component.

Following is a list of situations that require a flushing procedure be done:

1. The compressor has an internal failure.
2. No oil remains in used compressor.
3. Oil drained from compressor appears or smells overheated.
4. System was contaminated with a mixture of refrigerant oils.
5. System was left open to the atmosphere long enough for dirt, moisture, or debris to enter the tubing or components.
6. System has an internal blockage.

The following solvent is recommended for flushing air conditioner systems. Use only solvents with an equivalent MSDS.

- TY16134 Air Conditioning System Flushing Solvent

### Purging

Purging the system or a component is a cleaning process using a gas to force liquid from the system. Purging alone will not remove refrigerant oil from the system.

Following is a list of situations that require a purging procedure be done:

- After flushing system with solvent, to prevent oil dilution
- System was contaminated with nitrogen or two refrigerants.
- System was left open to the atmosphere and flushing could not be performed.
- Installation of new lines, condenser, or evaporator was required.

### Evacuating

Evacuating the system is a process to remove air and moisture from the system, creating a vacuum. See Evacuate R134a System. (Group 1830.)

MF82180,00001DD -19-17MAR06-1/1

## Purge R134a System

**IMPORTANT: Air compressors used for purging systems require a water separator. Purging without a separator adds moisture, creating hydrofluoric acid when combined with refrigerant oil. Acid is corrosive to metal tubing.**

1. Connect dry nitrogen hose to gauge manifold center hose.
2. Connect gauge manifold suction hose to compressor suction port, and open valves.
3. Connect gauge manifold discharge hose to compressor discharge post, and open valve. Disconnect discharge hose from gauge manifold to allow purging nitrogen to atmosphere.

4. Open nitrogen tank valve and adjust regulator to Specification. Purge system for two minutes. Disconnect nitrogen supply.

#### Specification

Nitrogen	
Purge—Pressure.....	275 kPa for two minutes
	2.75 bar for two minutes
	40 psi for two minutes

5. Evacuate system. See Evacuate R134a System. (Group 1830.)

CED, TX03399, 2292 -19-05MAY04-1/1

## Flush R134a System

Add flushing solvent to system with JT02075 Air Conditioning Flusher and JT02098 Fitting Kit.

*NOTE: Flushing can be performed on vehicle.*

1. Recover refrigerant. See Recover R134a System. (Group 1830.)
2. Remove compressor and measure oil drained from both manifold ports.
3. Clean compressor as follows:

- a. Pour specified amount of flushing solvent into suction port and Specified amount of flushing solvent into discharge port. Plug both ports in compressor manifold, using Caps.

### Specification

Compressor Flushing Solvent—Quantity in Suction Port.....	240 mL 8 fl oz
Quantity in Discharge Port.....	120 mL 4 fl oz

- b. Turn compressor end for end and roll it side to side.
  - c. Remove both plugs from manifold ports and drain solvent from compressor.
  - d. Connect battery power to compressor clutch coil. Rotate pulley at least five revolutions to move solvent out of cylinders.
  - e. Invert compressor, roll end for end, and side to side. Drain thoroughly.
  - f. Let compressor sit inverted for three to five minutes.
  - g. Repeat previous two steps at least three times.
4. Remove and discard receiver-dryer.
  5. Divide system into two circuits:
    - a. Condenser, including inlet and outlet hoses.
    - b. Evaporator, including inlet and outlet hoses.

**IMPORTANT: DO NOT attempt to flush through compressor or receiver-dryer. Flushing through expansion valve is acceptable if refrigerant oil has normal odor and appearance.**

### 6. To Flush/Purge Condenser:

Connect flusher outlet hose to inlet end of compressor discharge line using JT02102 Adapter.

7. Attach a return hose and aerator nozzle to outlet end of receiver/dryer inlet hose using JT03197 Adapter. Put nozzle in container to collect flushing solvent.
8. Fill flusher tank with solvent and fasten all connections.

### Specification

Flusher Tank—Capacity.....	4 L 1 gal
----------------------------	--------------

*NOTE: Air pressure must be at least 620 kPa (6.2 bar) (90 psi) for flushing and purging.*

9. Connect a supply line of moisture-free compressed air or dry nitrogen to flusher air valve. Adjust regulator to specification.

### Specification

Regulated Air—Minimum Pressure.....	620 kPa 6.2 bar 90 psi
-------------------------------------	------------------------------

10. Open air valve to force flushing solvent into condenser circuit. Flusher tank is empty when hose pulsing stops. Additional flushing cycles are required if system is heavily contaminated with burned oil or metal particles.

**IMPORTANT: Purging the condenser circuit takes 10—12 minutes to thoroughly remove solvent.**

11. Disconnect hose from aeration nozzle to check circuit for solvent. Hold hose close to a piece of cardboard; continue purging until cardboard is dry.

## Flush Evaporator

1. If system is contaminated with burned refrigerant oil or debris, remove and bench flush evaporator. Go to Step 18 to flush evaporator through expansion valve, if oil appears normal. Remove evaporator. See Evaporator or Heater Core Remove and Install. (Group 1830.)
2. Force flushing solvent through evaporator inlet with compressed air.
3. Purge system until dry.
4. Reinstall evaporator.

## Flush Evaporator Through Expansion Valve

1. Connect flusher outlet hose to connection of receiver/dryer outlet hose using JT03188 Adapter.
2. Attach a hose and aerator nozzle to compressor inlet line using JT02101 Adapter. Put nozzle in a container to collect solvent.
3. Repeat Steps 8, 9 and 10 to flush evaporator.

*NOTE: Purging the evaporator circuit takes 12—15 minutes to thoroughly remove solvent.*

4. Disconnect hose from aeration nozzle to check circuit for solvent. Hold hose close to a piece of cardboard. Continue purging until cardboard is dry.

Install a new receiver-dryer compatible with R134a refrigerant. Tighten connections and mounting bracket.

Add required oil. See R134a Component Oil Charge. (Group 1830.)

Install compressor, and connect refrigerant lines to manifold.

Connect clutch coil wire. Install drive belt.

Purge system. See Purge R134a System. (Group 1830.)

CED,TX03399,2293 -19-05MAY04-2/2

## Evaporator or Heater Core Remove and Install

*NOTE: Anytime air conditioning system is discharged, a new receiver-dryer must be installed.*

1. Remove cap screws to remove access cover to air conditioning and heater assembly.
2. Recover air conditioning system. See Recover R134a System. (Group 1830.)
3. Disconnect (1, 2, 4—6, 8 and 9).
4. Remove Cap Screw (3) on both sides.
5. Remove eight screws (7) and remove A/C and heater assembly.

- |   |  |
|---|--|
| 1— Receiver-Dryer<br>Hose-to-Condenser                | 6— Expansion Valve<br>Hose-to-Compressor   |
| 2— Receiver-Dryer Hose from<br>Evaporator             | 7— Cap Screw (8 used)                      |
| 3— Cap Screw (2 used)                                 | 8— A/C Blower Fans and<br>Switch Connector |
| 4— Two Heater Hoses-to-Under<br>the Seat Heater Core  | 9— Low Pressure Switch<br>Connector        |
| 5— A/C Harness Connector-to-<br>Cab Harness Connector |  |

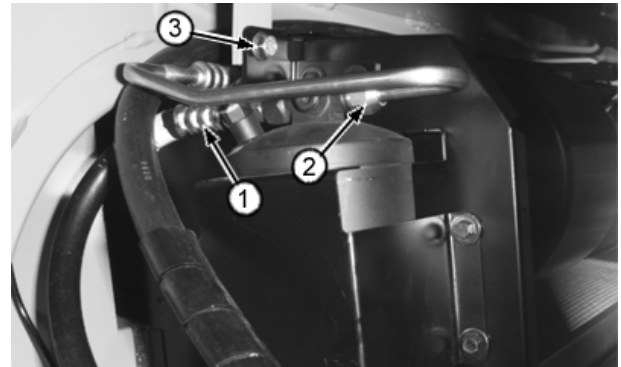

Receiver-Dryer Lines

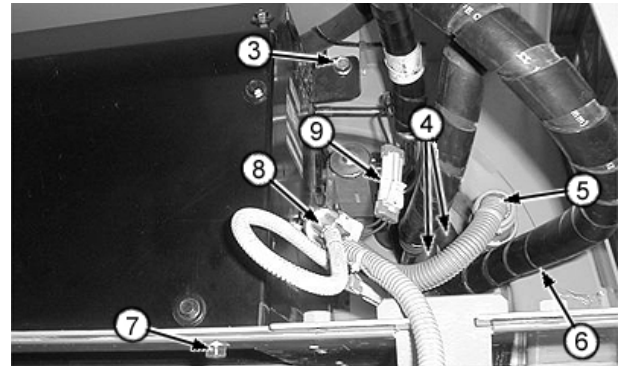

Expansion Valve, Plate and Bracket

T118219B—UN—03NOV98

T118220B—UN—05NOV98

KV70328,0000079 -19-16DEC09-1/3

6. Disconnect lines and bracket from expansion valve (14).
7. Remove two screws (12) and remove expansion valve.
8. Remove bracket (13).
9. Remove two cap screws and remove plate (10).
10. Remove cover (11) and remove evaporator or heater core.

- |                                     |                     |
|-------------------------------------|---------------------|
| 10— Plate                           | 13— Bracket         |
| 11— Evaporator/Heater Core<br>Cover | 14— Expansion Valve |
| 12— Cap Screw (2 used)              |                     |

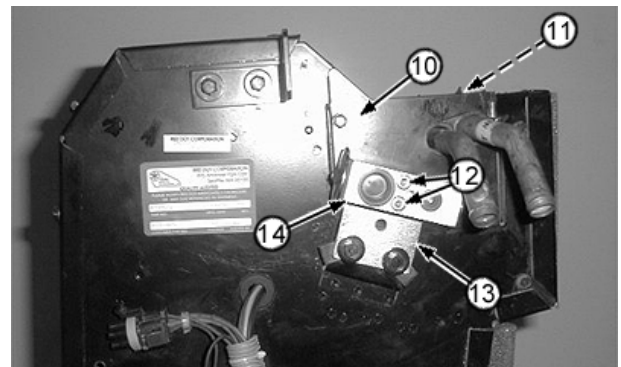

Expansion Valve, Plate and Bracket

T118221B—UN—03NOV98

Continued on next page

KV70328,0000079 -19-16DEC09-2/3

11. Install evaporator or heater core.
12. Install (11, 10, 13, and 14). Tighten cap screws.
13. Connect (4—6, 8 and 9). Tighten cap screws (3 and 7).
14. Connect hoses (1 and 2).
15. Install access cover and tighten cap screws.
16. Install new receiver/dryer.
17. Apply refrigerant oil to new O-rings and immediately connect lines.
18. Add oil. See R134a Component Oil Charge. (Group 1830)
19. Evacuate and charge the air conditioning system.  
See Evacuate R134a System (Group 1830) and See Charge R134a System. (Group 1830)

- |   |  |
|---|--|
| 1— Receiver-Dryer<br>Hose-to-Condensor                | 8— A/C Blower Fans and<br>Switch Connector |
| 2— Receiver-Dryer Hose from<br>Evaporator             | 9— Low Pressure Switch<br>Connector        |
| 3— Cap Screw (2 used)                                 | 10— Plate                                  |
| 4— Two Heater Hoses-to-Under<br>the Seat Heater Core  | 11— Evaporator/Heater Core<br>Cover        |
| 5— A/C Harness Connector-to-<br>Cab Harness Connector | 12— Cap Screw (2 used)                     |
| 6— Expansion Valve<br>Hose-to-Compressor              | 13— Bracket                                |
| 7— Cap Screw (8 used)                                 | 14— Expansion Valve                        |

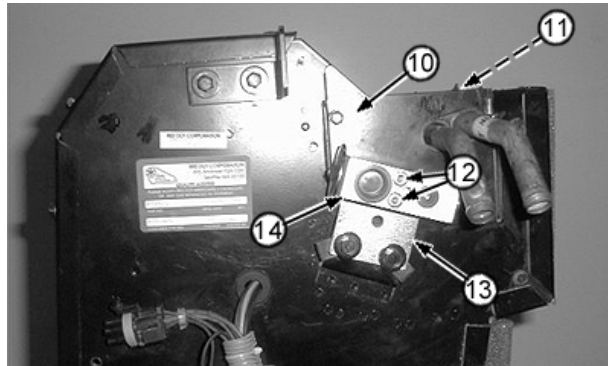

Expansion Valve, Plate and Bracket

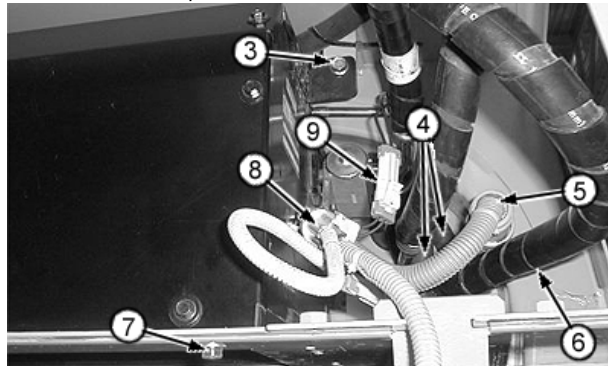

Receiver/Dryer Lines

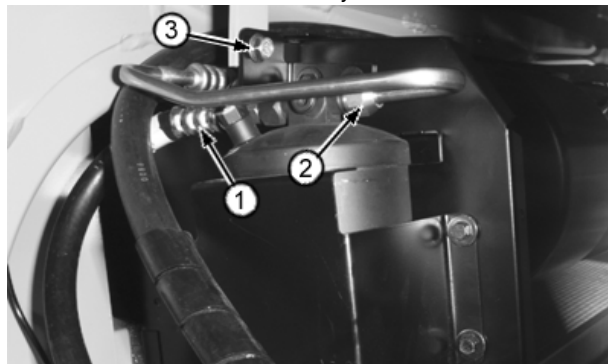

A/C and Heater Lines and Wiring Connectors

T118221B—UN—03NOV98

T118220B—UN—05NOV98

T118219B—UN—03NOV98

KV70328,0000079 -19-16DEC09-3/3

### Expansion Valve Remove and Install

**NOTE:** Anytime air conditioning system is discharged, a new receiver-dryer must be installed.

1. Open Access cover
2. Recover the air conditioning system. See Recover R134a System. (Group 1830.)
3. Disconnect hoses (1 and 3) and remove cap screw and bracket (2).
4. Remove two screws on expansion valve and remove valve.
5. Install valve, bracket and connect hoses.
6. Install new receiver-dryer. See Receiver-Dryer Remove and Install. (Group 1830.)
7. Apply refrigerant oil to new O-rings and immediately connect lines.
8. Add oil. See R134a Component Oil Charge. (Group 1830.)

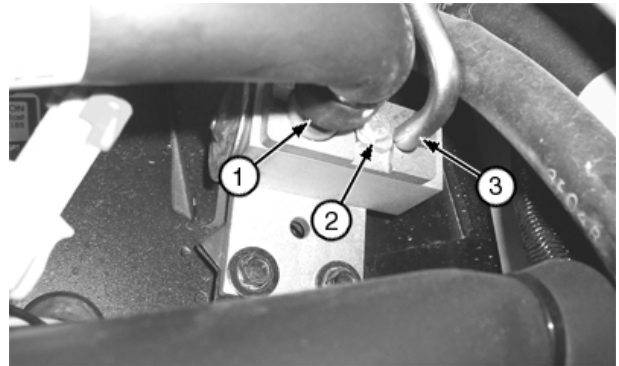

Expansion Valve

1— Expansion Valve  
Hose-to-Compressor  
2— Cap Screw and Bracket

3— Expansion Valve  
Hose-to-Receiver/Dryer

9. Evacuate and charge the air conditioning system. See Evacuate R134a System and See Charge R134a System. (Group 1830.)

KV70328,000007A -19-14JUN06-1/1

T200241A —UN—20MAY04

### A/C Freeze Switch Remove and Install

1. Disconnect connector (1).
2. Remove sensor (2) from evaporator.
3. Remove cap screws (3).

1— Connector  
2— Sensor

3— Cap Screw (2 used)

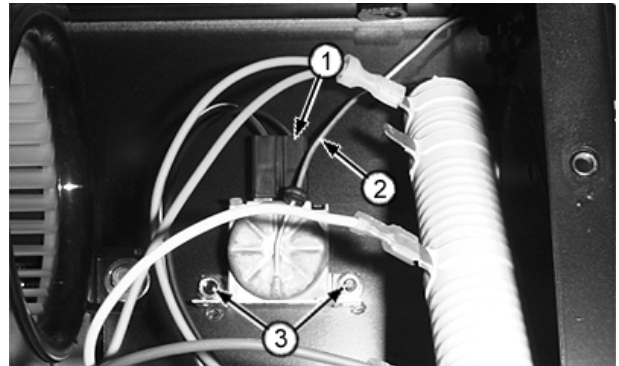

CED,TX03399,5071 -19-06MAY04-1/1

T118417B —UN—16NOV98

### Upper Cab Heater Blower Motor and Heater Blower Resistor Remove and Install

1. Remove A/C and heater access cover.
2. Remove blower motor cover (for blower motor only).
3. Disconnect blower motor connectors (3). Remove cap screws (1 and 2).
4. Remove blower motor.
5. Disconnect leads (5) and cap screw (4) to remove heater resistor.
6. Install new resistor and connect leads and install cap screw (4).
7. Install blower motor and connect connectors.
8. Install covers.

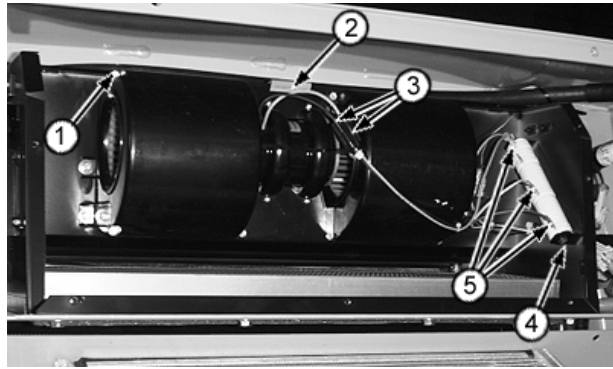

T118407B —UN—16NOV98

1— Cap Screw (4 used)  
2— Cap Screw  
3— Blower Motor Connector (2 used)

4— Resistor Cap Screw  
5— Resistor Wire Lead (3 used)

CED, TX03399, 5066 -19-29JUL09-1/1



### Cab Upper Heater Disassemble and Assemble

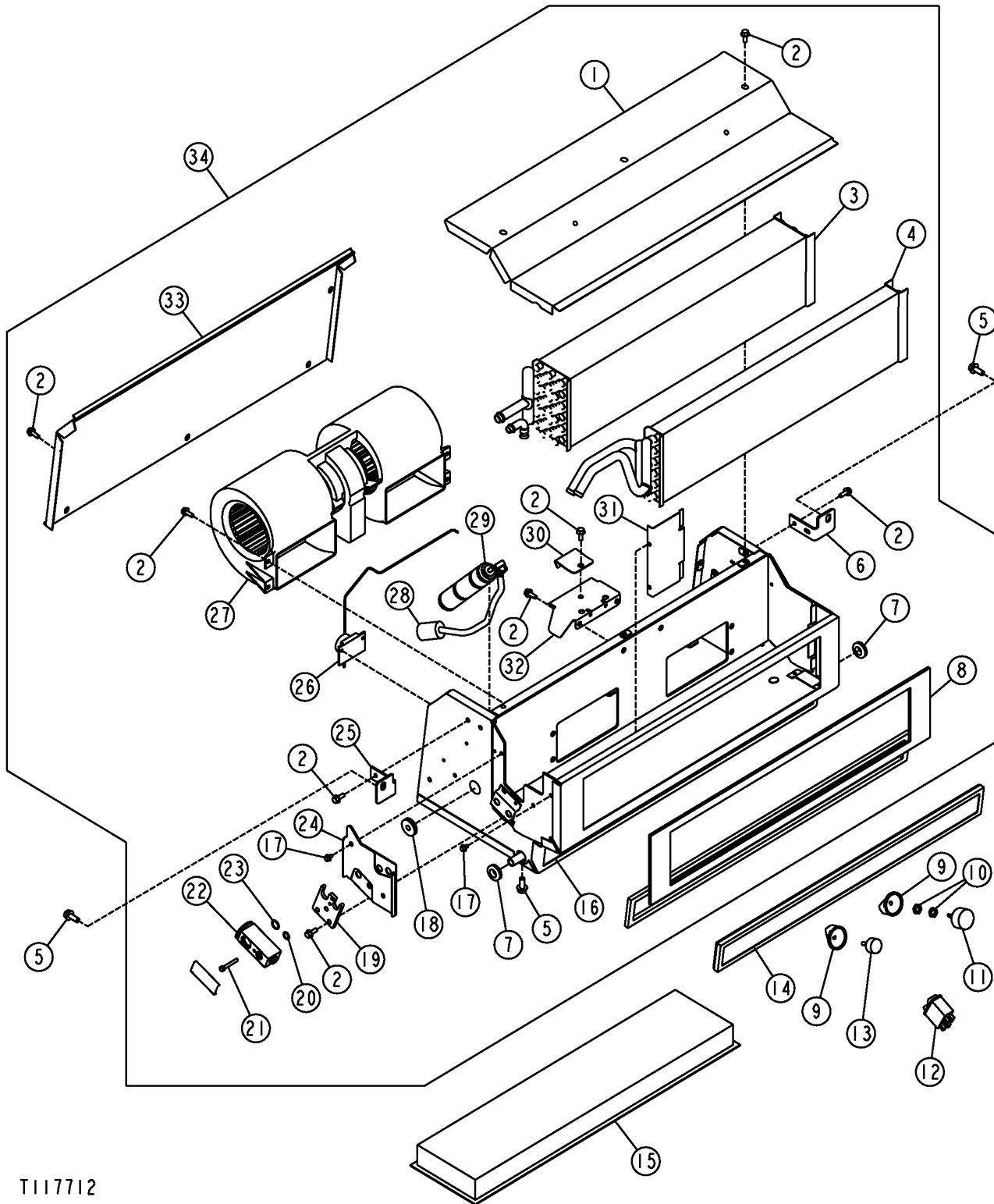

T117712

T117712 —UN—15DEC98

Continued on next page

CED.TX03399.5025 -19-09MAR06-1/2

*Heating and Air Conditioning*

1— Top Cover	10— Nut (2 used)	19— Mount Plate	28— Wiring Harness
2— Cap Screw (24 used)	11— Rotary Switch	20— O-Ring	29— Resistor
3— Evaporator Core	12— Heater Switch	21— Cap Screw (2 used)	30— Motor Support Retainer
4— Heater Core	13— Heater Control Switch	22— Thermal Expansion Valve	31— Motor Retainer
5— Cap Screw (10 used)	14— Recirculation Filter	23— O-Ring	32— Bracket
6— Bracket	15— Fresh Air Filter	24— Plate	33— A/C Back Cover
7— Grommet (2 used)	16— Main Housing	25— Bracket	34— Upper Heater Assembly
8— Gasket Kit	17— Cap Screw (4 used)	26— Freeze Control Switch	
9— Switch Knob (2 used)	18— Grommet	27— Blower Fan	

CED, TX03399, 5025 -19-09MAR06-2/2

### Cab or ROPS Under Seat Heater Disassemble and Assemble

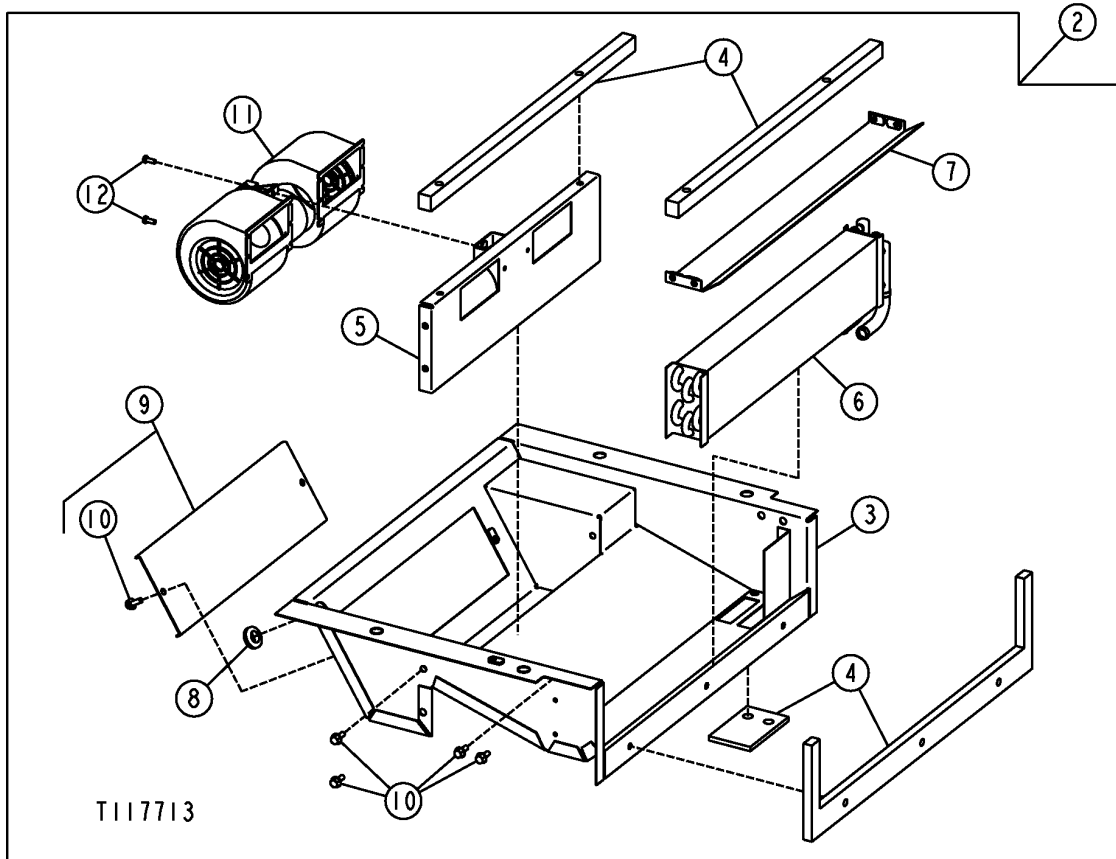
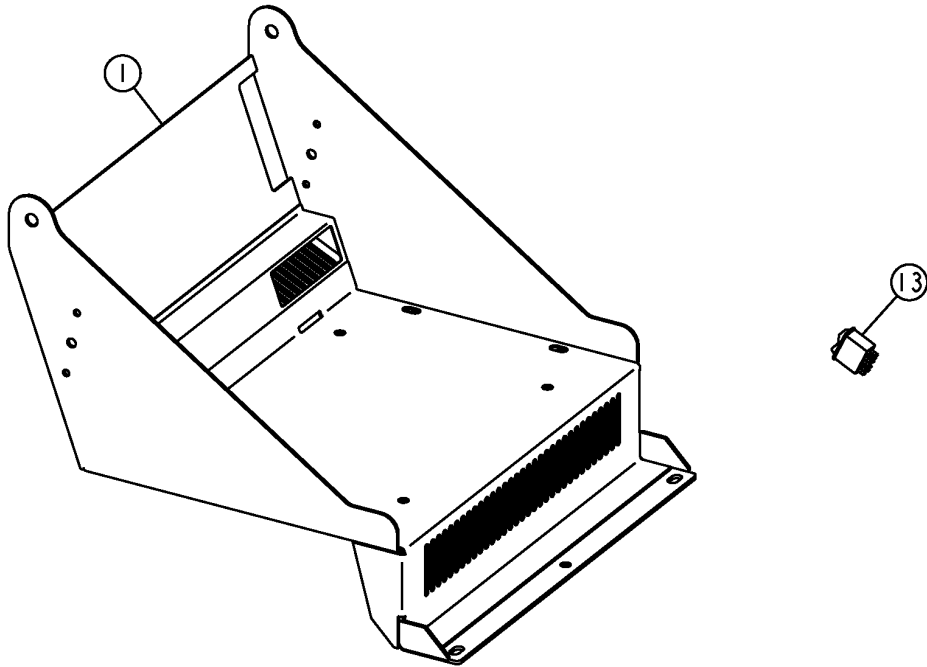

T117713

T117713—UN—03DEC98

Continued on next page

CED, TX03399, 5024 -19-06MAY04-1/3

## Heating and Air Conditioning

- 1— Heater Base
- 2— Heater Assembly
- 3— Heater Tray
- 4— Gasket Kit

- 5— Blower Motor Bulkhead
- 6— Heater Core
- 7— Support
- 8— Wiring Harness (Not Shown)  
with Grommet

- 9— Backing Plate
- 10— Cap Screw (10 used)
- 11— Blower
- 12— Cap Screw (2 used)

- 13— Switch

1. Drain engine coolant. See Drain and Refill Capacities for amount. (Operator's Manual.)
2. Remove floor mat and floor access plate.
3. For machines equipped with a toolbox, pull out drawer and remove cap screw holding toolbox in place. Remove toolbox.

CED, TX03399, 5024 -19-06MAY04-2/3

4. Remove four cap screws (A) from around seat box bottom.
5. Remove shoulder cap screws (C) from seat box under armrest (B) on both sides of seat.
6. Remove two cap screws from knee pad (E) on both sides of seat (if equipped).
7. On units equipped with rear screen or cab, tilt back of seat forward.
8. Tilt seat up as far as possible with jack screw (D) located in left rear corner of seat box.
9. Disconnect blower wire connector and heater hoses.
10. Remove heater/blower assembly
11. Remove part as necessary.
12. Assemble parts and lower seat.
13. Install floor access plate and floor mat.
14. Fill engine coolant. See Drain and Refill Capacities. (Operator's Manual.)

- A—Cap Screws Around Seat Box Bottom (4 used)
- B—Armrest
- C—Shoulder Cap Screws (2 used)

- D—Jack Screw
- E—Knee Pad



T116757B —UN—21AUG98

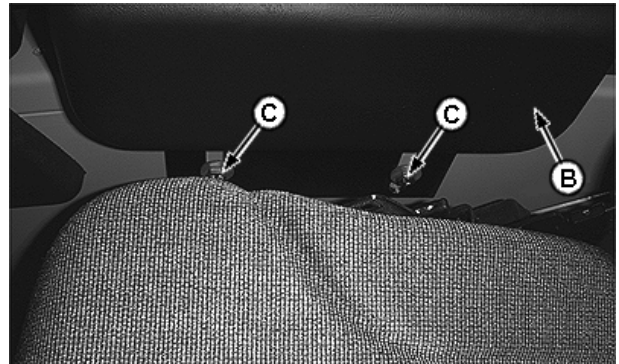

T116757B —UN—21AUG98

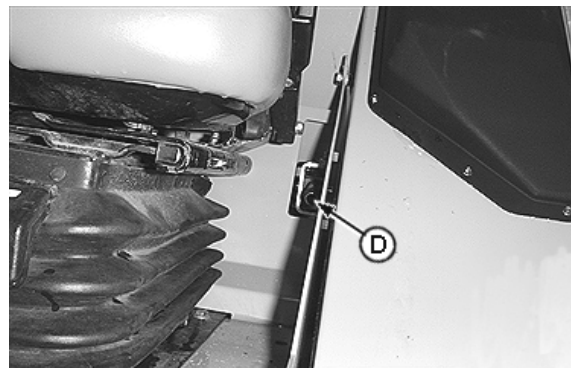

T200435A —UN—27MAY04

CED, TX03399, 5024 -19-06MAY04-3/3

### Receiver-Dryer Remove and Install

**NOTE:** Anytime air conditioning system is discharged, a new receiver-dryer must be installed.

1. Remove left hand side cover.
2. Recover the air conditioning system. See Recover R134a System. (Group 1830.)
3. Disconnect hoses (1 and 3) and remove four cap screws (2) and remove receiver-dryer.
4. Install new receiver-dryer, and bracket. Tighten cap screws.
5. Apply refrigerant oil to new O-rings and immediately connect lines.
6. Add oil. See R134a Component Oil Charge. (Group 1830.)
7. Evacuate and charge the air conditioning system. See Evacuate R134a System and see Charge R134a System. (Group 1830.)

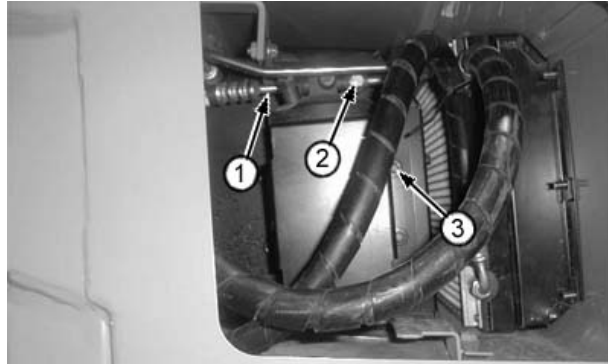

T118142B—UN—02NOV98

1— Receiver/Dryer  
Hose-to-Condenser  
2— Receiver/Dryer  
Hose-from-Evaporator

3— Receiver/Dryer Bracket  
Screw (4 used)

CED,OUTX547,181 -19-09MAR06-1/1

### Condenser Remove and Install

**NOTE:** Anytime air conditioning system is discharged, a new receiver-dryer must be installed.

*If servicing the condenser fans do not disconnect condenser hoses. Remove condenser and lay to the side.*

1. Remove bottom cover.
2. Recover the air conditioning system. See Recover R134a System. (Group 1830.)
3. Disconnect hoses (1 and 3) and remove six cap screws (2) and remove condenser.
4. Install condenser. Tighten cap screws.
5. Connect lines (1 and 3).
6. Install a new receiver-dryer. See Receiver-Dryer Remove and Install. (Group 1830.)
7. Apply refrigerant oil to new O-rings connect lines.
8. Add compressor oil. See R134a Component Oil Charge. (Group 1830.)

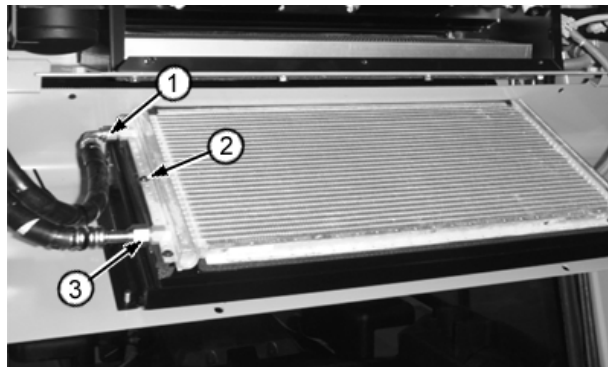

T118149B—UN—02NOV98

1— From Receiver-Dryer-to-  
Condenser Hose  
2— Cap Screw (6 used)

3— Condenser-to-Compressor  
Hose

9. Evacuate and charge the air conditioning system. See Evacuate R134a System and see Charge R134a System. (Group 1830.)

CED,OUTX547,183 -19-09MAR06-1/1

### Compressor Remove and Install

*NOTE: Anytime air conditioning system is discharged, a new receiver-dryer must be installed.*

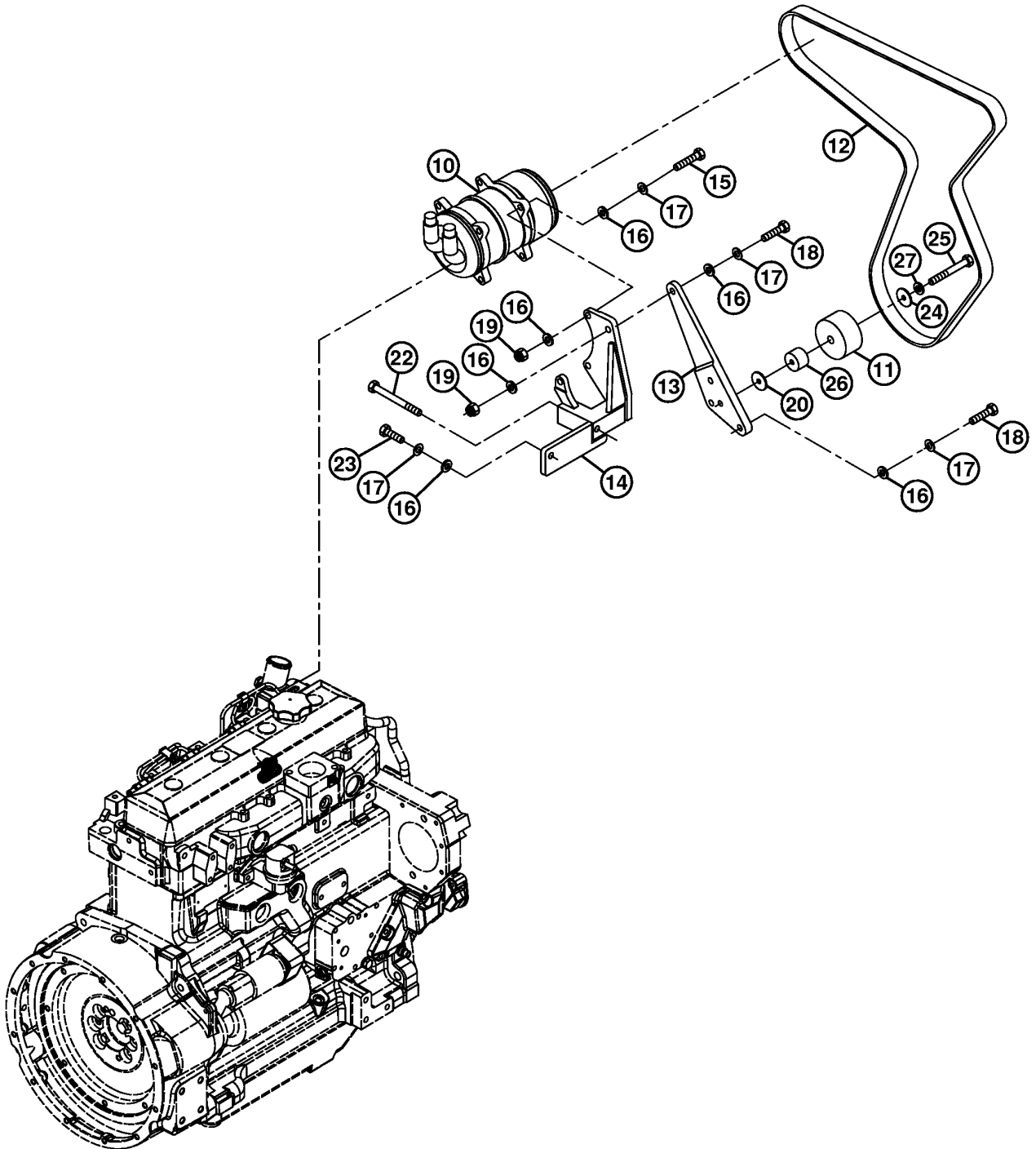

T216793

Compressor  
Continued on next page

CED, TX03399, 5020 -19-16DEC09-1/4

T216793 —UN—01NOV05

## Heating and Air Conditioning

- |                   |               |               |              |
|-------------------|---------------|---------------|--------------|
| 10— Compressor    | 15— Cap Screw | 20— Washer    | 26— Tube Nut |
| 11— Idler         | 16— Washer    | 22— Screw     | 27— Washer   |
| 12— Adjuster Belt | 17— Washer    | 23— Cap Screw |              |
| 13— Clamp         | 18— Cap Screw | 24— Sleeve    |              |
| 14— Bracket       | 19— Lock Nut  | 25— Screw     |              |

- Remove refrigerant from the system. See Recover R134a System. (Group 1830.)

CED, TX03399, 5020 -19-16DEC09-2/4

- Disconnect wiring harness (3), suction hose (4) and discharge hose (5).

- |                   |                   |
|-------------------|-------------------|
| 3— Wiring Harness | 5— Discharge Hose |
| 4— Suction Hose   |                   |

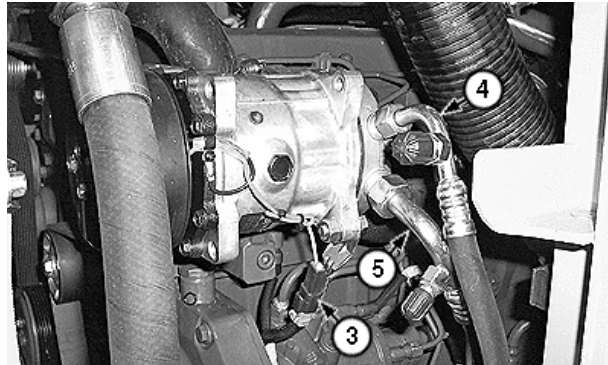

TX1005151A —UN—23MAR06

CED, TX03399, 5020 -19-16DEC09-3/4

- Loosen screw (1) and tensioner (2) to remove adjuster belt (12).
- Remove three cap screws (15) and compressor (10).
- Install compressor and tighten cap screws.
- Connect suction hose, discharge hose and wiring harness.
- Install belt.
- Install new receiver-dryer. See Receiver-Dryer Remove and Install. (Group 1830.)
- Evacuate and charge the air conditioning system. See Evacuate R134a System and see Charge R134a System. (Group 1830.)

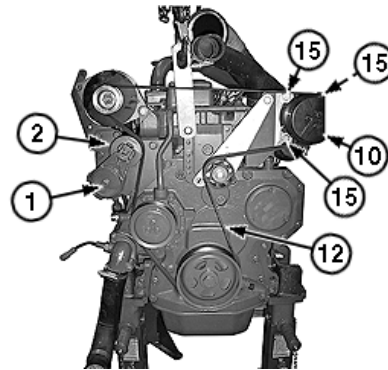

- |                |                   |
|----------------|-------------------|
| 1— Screw       | 12— Adjuster Belt |
| 2— Tensioner   | 15— Cap Screw     |
| 10— Compressor |                   |

TX1005148A —UN—23MAR06

CED, TX03399, 5020 -19-16DEC09-4/4

**IMPORTANT: When turning air conditioning on for the first time, set the engine rpm at slow idle to avoid possible high pressure discharge of extra refrigerant oil that is in all new compressors.**

### Compressor Remove and Install

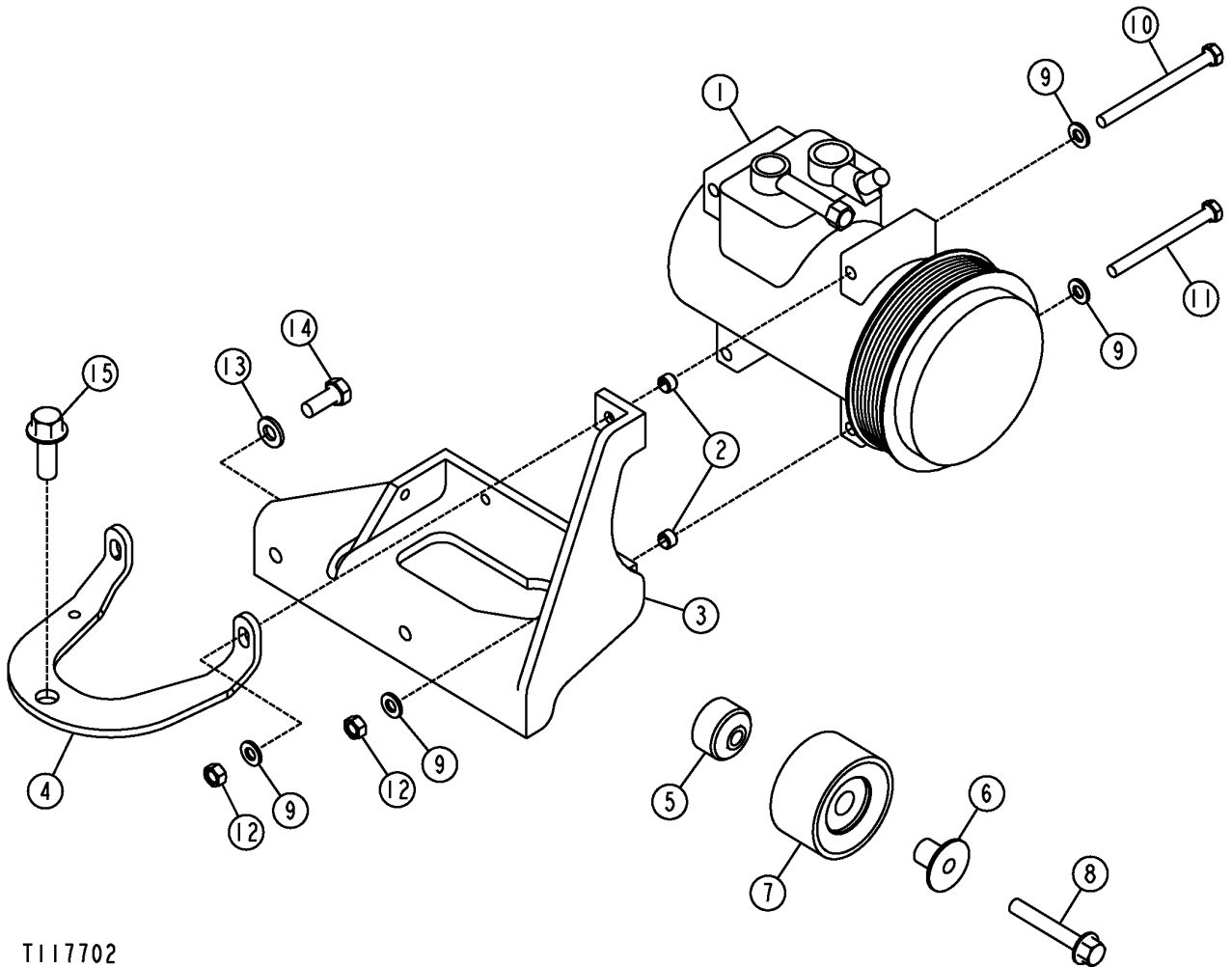

T117702

T117702—UN—22OCT98

*Compressor and Bracket*

- |                       |             |                       |                       |
|-----------------------|-------------|-----------------------|-----------------------|
| 1—Compressor          | 5—Spacer    | 9—Washer (6 used)     | 13—Washer (2 used)    |
| 2—Spring Pin (2 used) | 6—Sleeve    | 10—Cap Screw          | 14—Cap Screw (2 used) |
| 3—Bracket             | 7—Pulley    | 11—Cap Screw (3 used) | 15—Cap Screw          |
| 4—Support             | 8—Cap Screw | 12—Nut (3 used)       |                       |

1. Remove refrigerant from the system. See Recover R134a Refrigerant. (Group 1830.)
2. Loosen belt adjuster and remove belt
3. Disconnect wiring lead, suction and discharge lines.
4. Remove four cap screws and compressor.
5. Repair or replace compressor. See Compressor Disassemble and Assemble. (Group 1830)
6. Install compressor and tighten cap screws.

Support Bracket-to-Engine Block Cap Screws—Torque.....	120 N·m 89 lb-ft
Compressor Bracket-to-Engine Block Cap Screws—Torque.....	70 N·m 52 lb-ft
Idler Pulley-to-Fan Drive Cap Screws—Torque.....	50 N·m 37 lb-ft

**Specification**

Compressor-to-Bracket Cap Screws—Torque.....	35 N·m 26 lb-ft
--	--------------------

7. Connect suction and discharge lines and wiring lead.
8. Install belt.
9. Install new receiver-dryer.

Continued on next page

KV70328.000007B -19-10DEC08-1/2

*Heating and Air Conditioning*

10. Evacuate and charge the air conditioning system.  
See Evacuate R134a System and see Charge R134a  
System. (Group 1830.)

**avoid possible high pressure discharge of extra  
refrigerant oil that is in all new compressors.**

**IMPORTANT: When turning air conditioning on for  
the first time, set the engine rpm at slow idle to**

KV70328,000007B -19-10DEC08-2/2

## Compressor Clutch Disassemble and Assemble

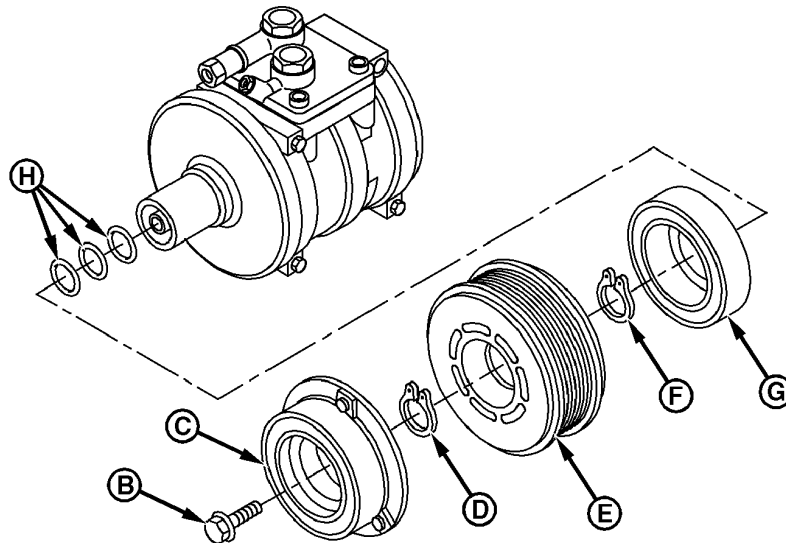

T114965

1. Mount compressor on D01006AA Bench Mounted Holding Fixture or DFRW20 Compressor Holding Fixture using two 6 in. x 1/4 in. eye bolts with nuts as illustrated.
2. Remove dust cover.
3. Hold the clutch hub using JDG747 Compressor Clutch Spanner (A) and remove the clutch shaft bolt (B).
4. Remove the clutch hub (C). Remove the shims (H) from the clutch hub and save for installation.
5. Remove and discard snap ring (D). Remove the pulley (E) using a plastic hammer or JDG220 Puller, JDG748 Jaws and JDG771 Forcing Screw.
6. Disconnect the clutch coil lead wire. Remove and discard the snap ring (F) and remove the clutch coil (G).

**NOTE:** The bearing in the pulley is not serviceable.

7. Check pulley bearing operation. Replace pulley and bearing as required.
8. Install the clutch coil and new snap ring with flat side of the snap ring down. Connect the clutch coil lead wire.
9. Install the pulley and new snap ring with the flat side of the snap ring down. Apply grease to the shims (H) and install to the clutch hub.
10. Install clutch hub and shaft bolt and tighten.

### Specification

Compressor Hub	
Retaining Nut—Torque.....	14 N·m 124 lb-in.

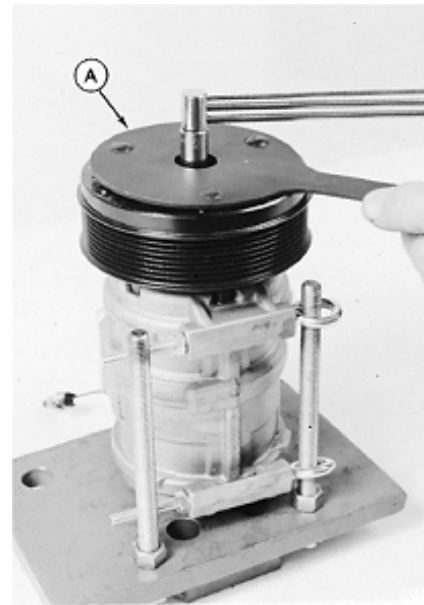

A—JDG747 Compressor Clutch Spanner  
B—Clutch Shaft Bolt  
C—Clutch Hub  
D—Pulley Snap Ring

E—Pulley  
F—Clutch Coil Snap Ring  
G—Clutch Coil  
H—Shims

T114965 —UN—29APR08

RWZ1157 —UN—24JUN92

TX,18,RB761 -19-17MAR06-1/1

### Clutch Hub Clearance Check

**NOTE:** The clutch coil is not polarity sensitive.

1. Check pulley-to-clutch hub clearance using a dial indicator. Mount the gauge to the pulley as illustrated and connect a set of jumper wires from the compressor to a 12V battery.
2. Rotate the pulley and check clearance in three equally spaced locations around the clutch hub. Add or remove shims to obtain specified clearance.

**Specification**

Air Conditioning	
Clutch Hub-to-	
Pulley—Clearance.....	0.35—0.65 mm
	0.014—0.026 in.

3. Tighten clutch shaft bolt to specification after correct clearance is obtained.

**Specification**

Air Conditioning Clutch	
Shaft Bolt—Torque .....	14 N·m
	124 lb-in.



RW21159 —JUN—24JUN92

TX,18,RB762 -19-17MAR06-1/1

### Compressor Manifold Inspect

1. Remove cap screws (A) and the manifold (B).
2. Remove and discard seal (C). Inspect porting surfaces.
3. Lubricate and install a new seal (C).
4. Install manifold and tighten cap screws.

**Specification**

Manifold Through	
Bolt—Torque.....	26 N·m
	230 lb-in

**A—Manifold Cap Screw**  
**B—Manifold**

**C—Manifold Seal**

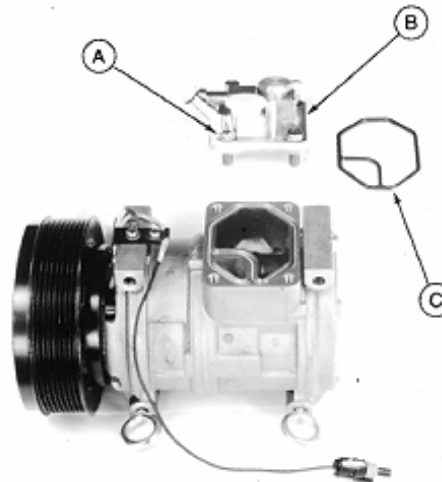

RW21160 —JUN—24JUN92

TX,18,RB763 -19-17APR06-1/1

**Compressor Disassemble and Assemble**

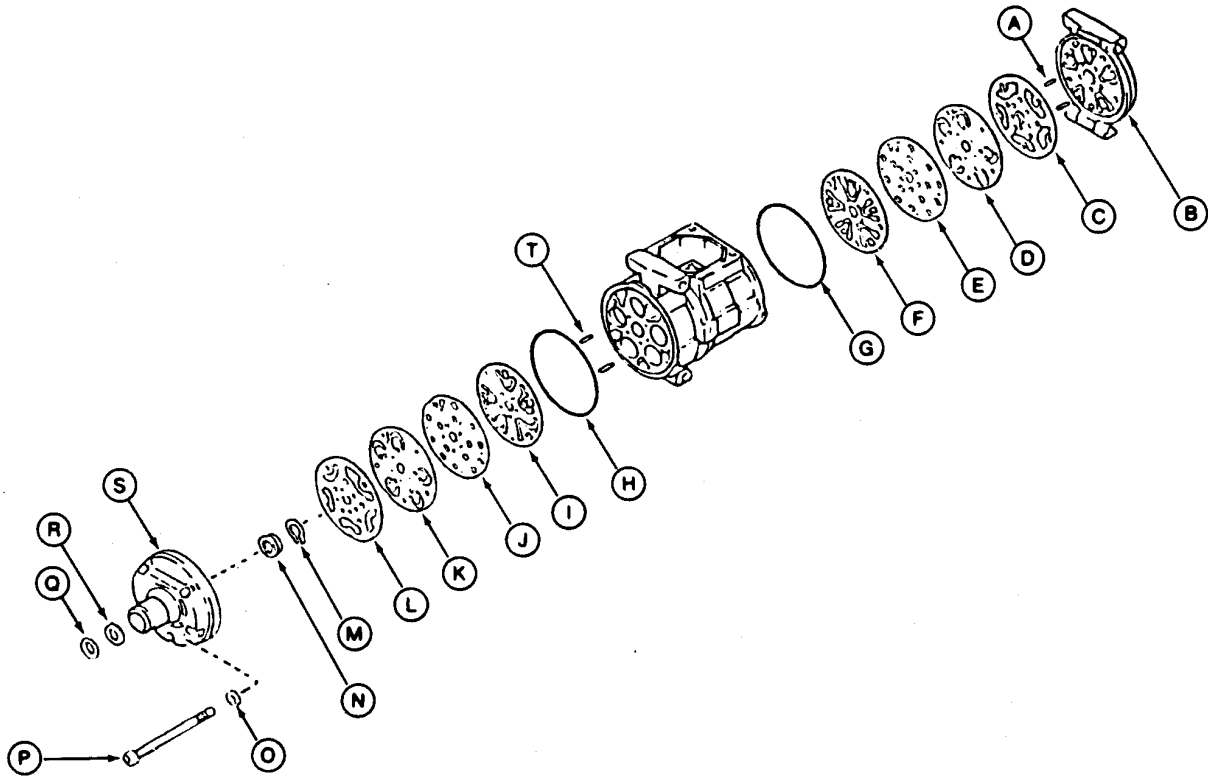

- |                             |                            |                              |                 |
|-----------------------------|----------------------------|------------------------------|-----------------|
| A—Rear Pins                 | F—Rear Suction Reed Valve  | K—Front Discharge Reed Valve | P—Through Bolt  |
| B—Rear Housing              | G—Rear O-Ring              | L—Front Gasket               | Q—Felt Holder   |
| C—Rear Gasket               | H—Front O-Ring             | M—Snap Ring                  | R—Felt          |
| D—Rear Discharge Reed Valve | I—Front Suction Reed Valve | N—Lip Seal                   | S—Front Housing |
| E—Rear Valve Plate          | J—Front Valve Plate        | O—Washer                     | T—Front Pins    |

Continued on next page

TX,18,RB764 -19-17MAR06-1/3

RW2161 — JUN—24JUN92

1. Clean the compressor using solvent before disassembly. Mount compressor on holding fixture and remove clutch. See Compressor Clutch Disassemble and Assemble. (Group 1830.)

**IMPORTANT: When removing front and rear housing, be careful not to damage the sealing surfaces.**

2. Disassemble the compressor as illustrated and discard the O-rings, gaskets, lip seal, snap ring, and through bolt washers. Replace parts from service kits.

*NOTE: The valve plates, reed valves, cylinders, and cylinder housings are not serviceable. Some cylinder scuffing (light scratches) is normal.*

3. Inspect the valves for an even wear pattern and the cylinders for scoring or excessive wear. Replace compressor as required.
4. Remove the shaft seal snap ring (M). Turn the housing over and remove the felt holder (Q) and felt (R) from the front housing (S).
5. Remove the shaft lip seal (N) from the front housing (S) using a small tool with 5/8 in. OD.
6. Wash all parts in clean solvent and dry before assembly.

**IMPORTANT: Lubricate O-rings, gaskets, and lip seal using only TY22025 (R134a) refrigerant oil during assembly. Other oils could damage the compressor.**

7. Apply R134a oil to the bore of the front housing and install new lip seal (N) to the bottom of the bore using a socket. Install new snap ring (M) flat side down.

**IMPORTANT: Bushing spacer (U) must be in position before assembling the compressor.**

8. Install pins (A) and new O-ring (G) in the rear cylinder.

*NOTE: The rear valve plate is marked with an "R" and is installed face up.*

9. Install parts (F—D) over the pins on the rear cylinder.

10. Install a new gasket (C) flat side down and the rear housing (B) on the rear cylinder. Mount the compressor onto the holding fixture.

11. Install pins (T) and new O-ring (H) in the front cylinder.

*NOTE: The front valve plate is marked with an "F" and is installed face up.*

12. Install parts (I—K) over the pins on the front cylinder.

13. Install a new gasket (L) flat side down. Put JDG746 lip seal protector on the shaft and lubricate with R134a oil.

14. Install the front housing (S) on the front cylinder and remove the lip seal protectors. Install through bolts (P) and new washers (O).

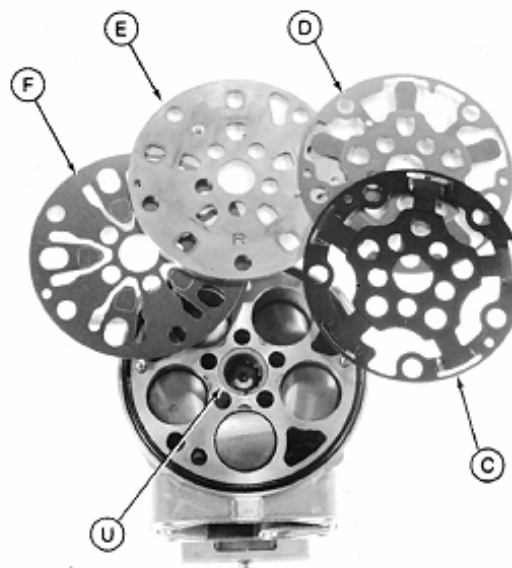

C—Rear Gasket  
 D—Rear Discharge Reed Valve  
 E—Rear Valve Plate  
 F—Rear Suction Reed Valve  
 U—Pump Body

15. Partially tighten the through bolts and then tighten to specification.

**Specification**

Air Conditioning	
Compressor Through Bolt—Torque.....	26 N·m
	230 lb-in.

16. Install the felt (R) and felt holder (Q) using the clutch hub.

Continued on next page

TX,18,RB764 -19-17MAR06-2/3

RW21162 —UN—24JUN92

RW21163 —UN—24JUN92

*Heating and Air Conditioning*

17. Install the pulley-clutch hub and check clearance. See  
Clutch Hub Clearance Check. (Group 1830.)

TX,18,RB764 -19-17MAR06-3/3



**Section 19**  
**Sheet Metal and Styling**

**Contents**

**Page**

**Group 1910—Hood and Engine Enclosure**

Hood Remove and Install ..... 19-1910-1

Hood Support and Engine Side Shields  
Remove and Install .....19-1910-3

**Group 1921—Grille and Grille Housing**

Grille and Grille Housing Removal..... 19-1921-1

Grille and Grille Housing  
Installation ..... 19-1921-4

Hood Remove and Install

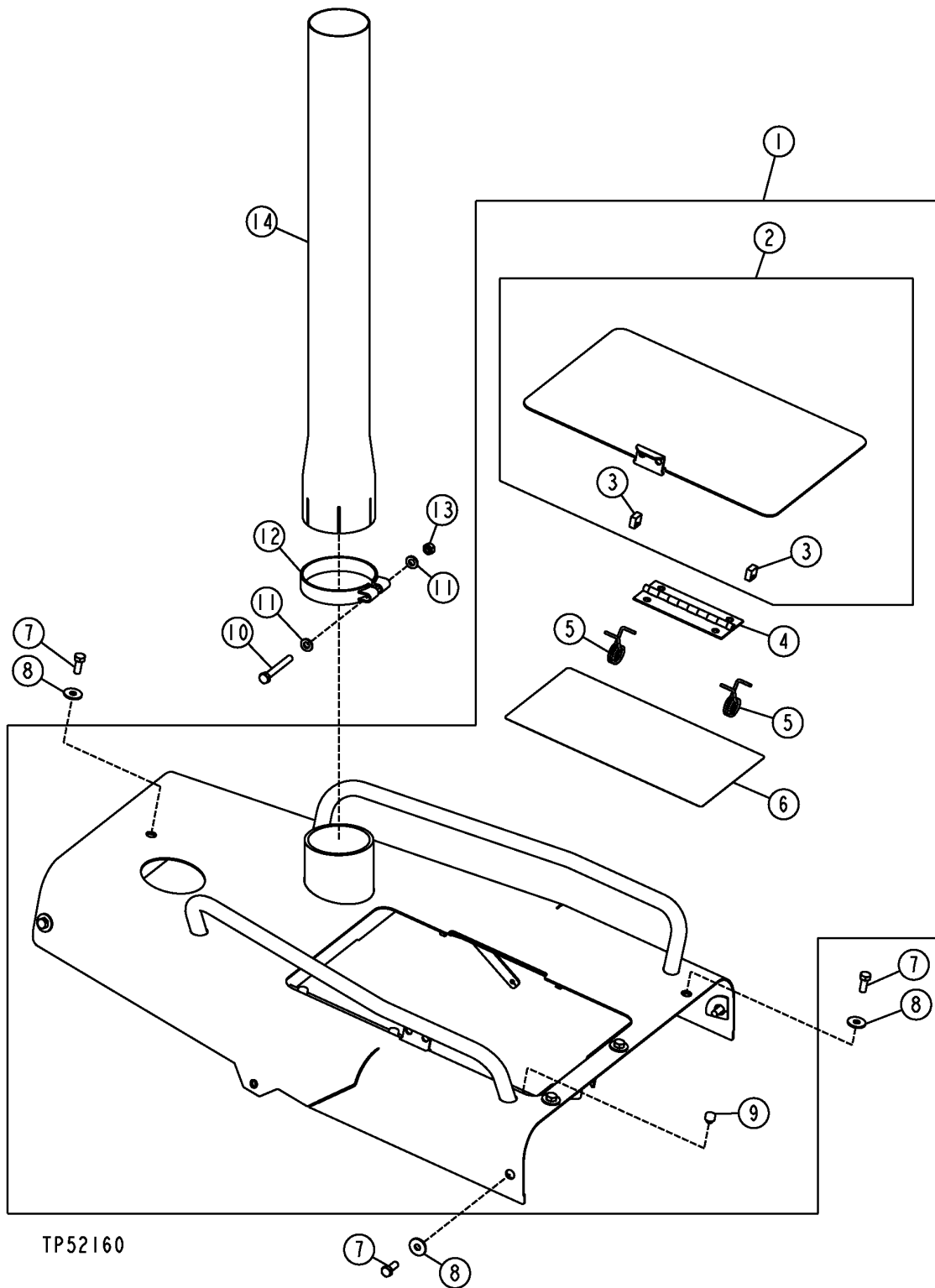

TP52160

TP52160—UN—14/JAN99

Continued on next page

CED.TX03399.5001 -19-16APR99-1/2

Hood and Engine Enclosure

- 1— Hood Assembly
- 2— Door
- 3— Strap (4 used)
- 4— Hinge

- 5— Spring (2 used)
- 6— Label
- 7— Cap Screw (8 used)
- 8— Washer (8 used)

- 9— Bumper (3 used)
- 10— Cap Screw
- 11— Washer (2 used)
- 12— Clamp

- 13— Nut
- 14— Extension

1. Remove engine side shields.
2. Disconnect wires on horn.
3. Disconnect oil fill tube clamp from hood (550J and 650J only).

4. Install strap and hoist.
5. Remove hood.
6. Remove parts as necessary.
7. Install hood. Tighten cap screws.
8. Connect ground wire on horn and install engine side shields.

**⚠ CAUTION: Prevent possible crushing injury from removing hood. Use proper lifting equipment and safety precautions.**

**Specification**

Hood—Weight..... 30 kg  
66 lb

CED, TX03399, 5001 -19-16APR99-2/2

**Hood Support and Engine Side Shields Remove and Install**

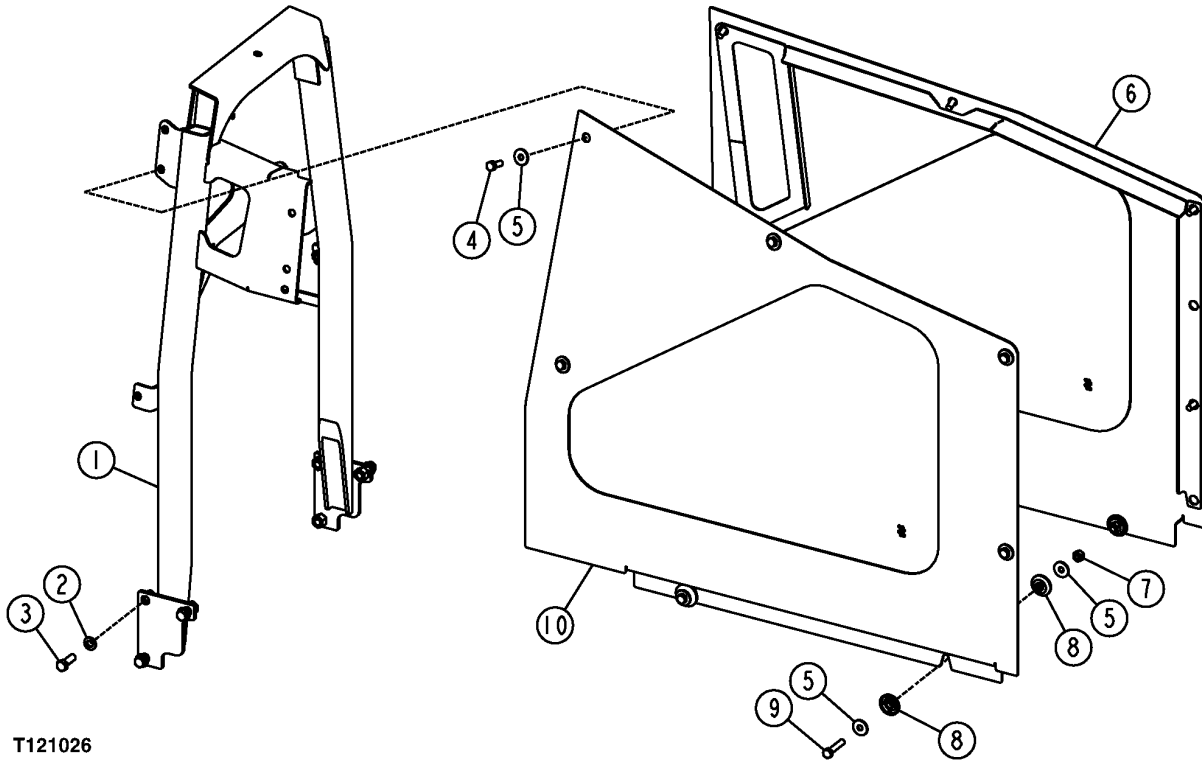

T121026

T121026—UN—14APR99

- 1— Hood Support
- 2— Washer (6 used)
- 3— Cap Screw (6 used)

- 4— Cap Screw (10 used)
- 5— Washer (18 used)
- 6— Shield (Left Engine Side)

- 7— Nut (4 used)
- 8— Guide (8 used)
- 9— Cap Screw (4 used)

- 10— Shield (Right Engine Side)

1. Remove and install when necessary.

2. Tighten cap screws.

CED,OUTX547,184 -19-16APR99-1/1

## Grille and Grille Housing Removal

1. Lower all equipment to the ground. Operate hydraulic controls to relieve pressure in the system.
2. Remove cap screw (1) and pull hoses away from grille.

**CAUTION:** Prevent possible crushing injury from removing grille. Use proper lifting equipment and safety precautions.

### Grille—Specification

450J Standard	
Grille—Weight.....	22.8 kg 50 lb
550J and 650J Standard	
Grille—Weight.....	28 kg 62 lb
450J Heavy Duty	
Grille—Weight.....	52.4 kg 116 lb
550J and 650J Heavy Duty Grille—Weight.....	
	64 kg 141 lb

3. Connect grille to hoist. Remove cap screws and remove grille.
4. Disconnect head light wire connectors and remove head lights and panel (2).

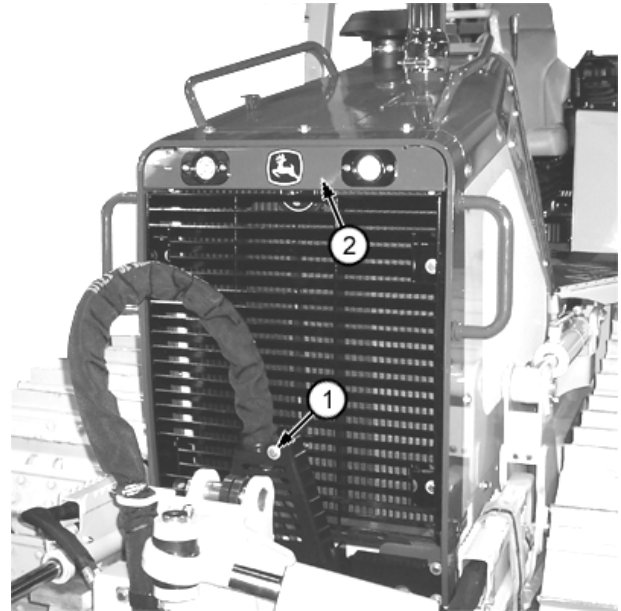

Standard Grille

1— Cap Screw

2— Head Lights and Panel

T199714A —UN—05MAY04

CED, TX03399, 5002 -19-29, JUL09-1/3

**CAUTION:** Prevent possible crushing injury from removing hood. Use proper lifting equipment and safety precautions.

### Grille Housing—Specification

450J Grille	
Housing—Weight.....	32 kg 71 lb
550J and 650J Grille	
Housing—Weight.....	36 kg 80 lb

5. Connect grille housing to hoist, using lifting straps around handles.
6. Remove radiator/oil cooler-to-grille housing cap screws (2).
7. Remove rubber mounts (1).

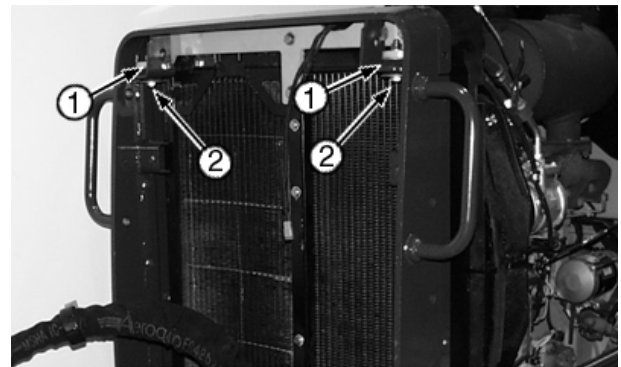

1— Rubber Mounts (2 used)

2— Radiator/Oil Cooler-to-  
Grille Housing Cap Screw  
(2 used)

T119162B —UN—22DEC98

Continued on next page

CED, TX03399, 5002 -19-29, JUL09-2/3

## Grille and Grille Housing

8. Remove cap screws (1), allowing hose guard (3) to hang.
9. Remove cap screws (2) from grille housing.
10. Remove grille housing.

1— Cap Screw (6 used)  
2— Cap Screw (2 used)

3— Hose Guard

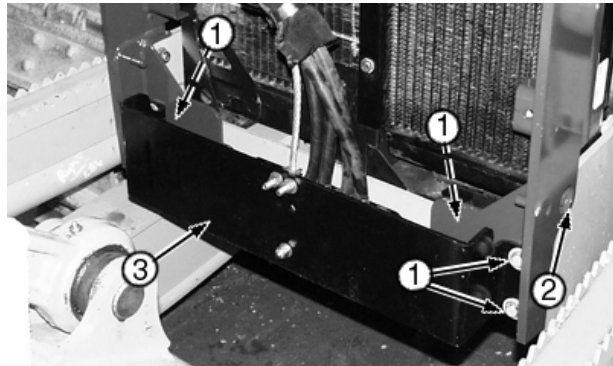

T119187B —UN—22DEC98

Standard Grille Hose Guard

CED,TX03399,5002 -19-29JUL09-3/3



### Grille and Grille Housing Installation

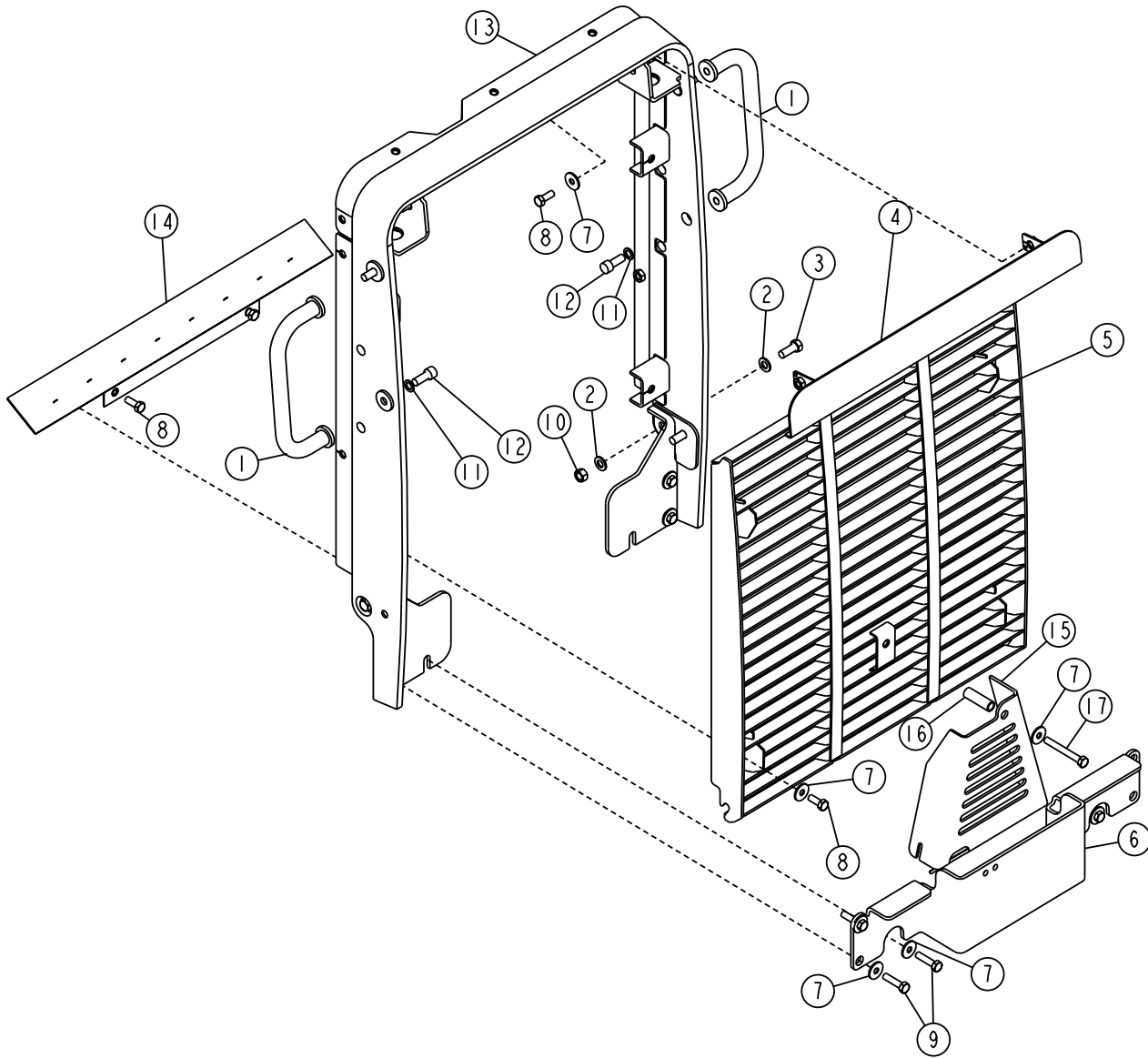

T142711

Standard Grille and Grille Housing

T142711 —UN—11JUN01

Continued on next page

CED, TX03399, 5003 -19-07JUN01-1/4

*Grille and Grille Housing*

1— Handle (2 used)  
2— Washer (4 used)  
3— Cap Screw (2 used)  
4— Head Light Plate  
5— Grille

6— Hose Guard  
7— Washer (12 used)  
8— Cap Screw (8 used)  
9— Cap screw (6 used)  
10— Nut (2 used)

11— Washer (4 used)  
12— Screw (4 used)  
13— Grille Frame  
14— Shield  
15— Hose Guard

16— Spacer  
17— Cap Screw

Continued on next page

CED, TX03399, 5003 -19-07JUN01-2/4

Grille and Grille Housing

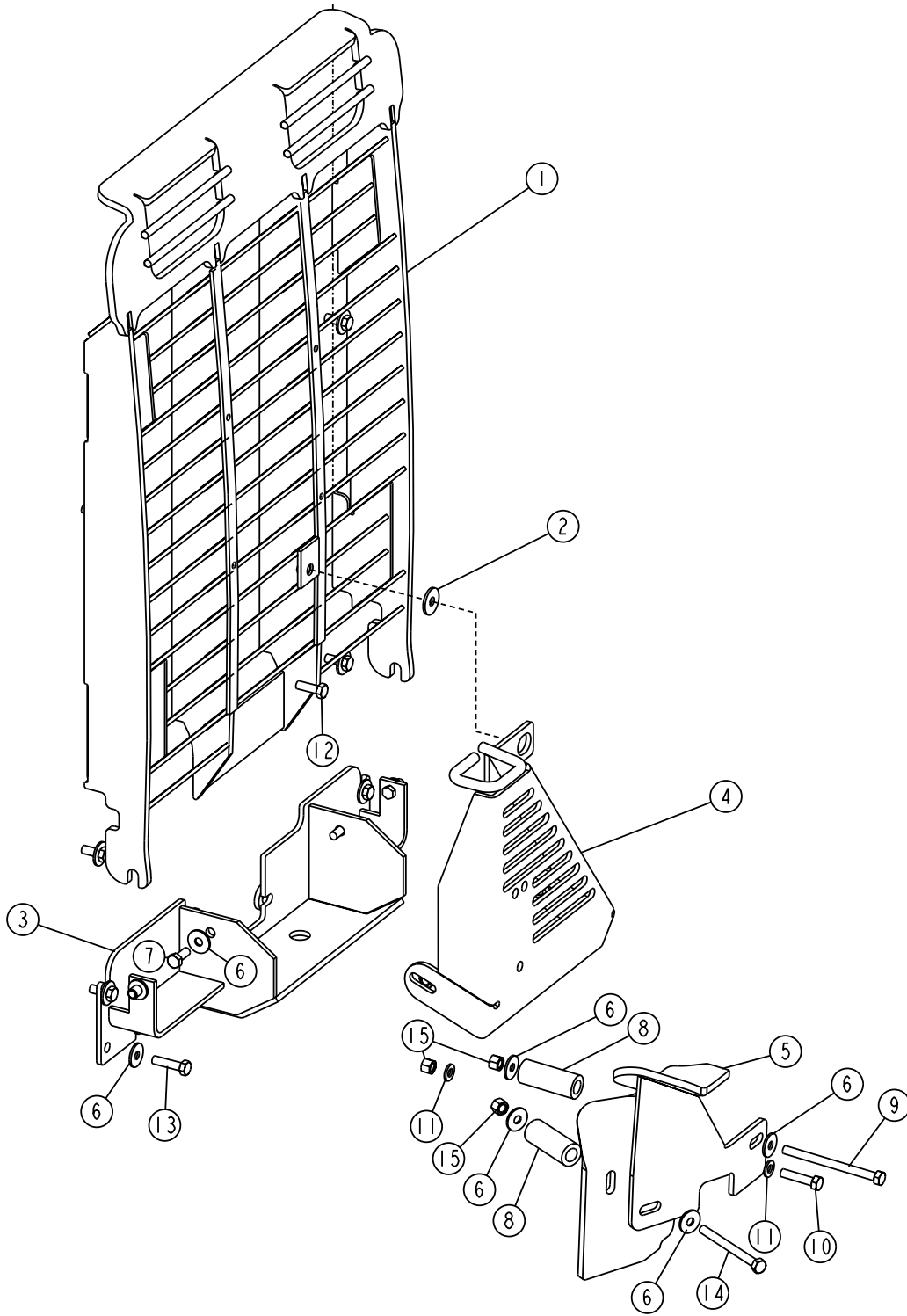

T142712—JUN—11JUN01

Heavy Duty Grille and Grille Housing

- |               |                       |                     |                        |
|---------------|-----------------------|---------------------|------------------------|
| 1— Grille     | 5— Hose Guard         | 9— Cap Screw        | 13— Cap Screw (4 used) |
| 2— Washer     | 6— Washer (6 used)    | 10— Cap Screw       | 14— Cap Screw          |
| 3— Hose Guard | 7— Cap Screw (8 used) | 11— Washer (2 used) | 15— Lock Nut (3 used)  |
| 4— Hose Guard | 8— Bushing (2 used)   | 12— Cap Screw       |                        |

Continued on next page

CED, TX03399, 5003 -19-07JUN01-3/4

*Grille and Grille Housing*

**⚠ CAUTION: Prevent possible crushing injury from removing grille housing. Use proper lifting equipment and safety precautions.**

**Grille Housing—Specification**

450J Grille	
Housing—Weight.....	32 kg 71 lb
550J and 650J Grille	
Housing—Weight.....	36 kg 80 lb

1. Connect grille housing to hoist using lifting straps around handles.
2. Install grille housing and upper rubber mounts. Tighten cap screws to specification.

**Specification**

Upper Radiator/Oil Cooler Bracket-to-Grill Housing Cap	
Screws—Torque.....	58 N·m 43 lb-ft

3. Install hose guards. Tighten cap screws to specification.

**Specification**

Grille Housing Cap	
Screws—Torque.....	73 N·m 54 lb-ft

4. Connect head light wire connectors and install head light plate.

**⚠ CAUTION: Prevent possible crushing injury from removing grille. Use proper lifting equipment and safety precautions.**

**Grille—Specification**

450J Standard Grille—Weight.....	22.8 kg 50 lb
550J and 650J Standard Grille—Weight.....	28 kg 62 lb
450J Heavy Duty Grille—Weight.....	52.4 kg 116 lb
550J and 650J Heavy Duty Grille—Weight.....	64 kg 141 lb

5. Install grille (5) and connect hoses to grille.

CED,TX03399,5003 -19-07JUN01-4/4

*Grille and Grille Housing*

## Section 21 Main Hydraulic System

### Contents

	Page
<b>Group 2160—Hydraulic System</b>	
Hydraulic Pump Remove and Install .....	21-2160-1
Hydraulic Pump (With Winch Option) Disassemble and Assemble .....	21-2160-3
Hydraulic Pump (Without Winch Option) Disassemble and Assemble .....	21-2160-7
Hydraulic Reservoir Remove and Install .....	21-2160-9
Hydraulic Reservoir and Hydrostatic Reservoir Cleanout Cover Remove and Install .....	21-2160-11
Disassemble and Assemble .....	21-2160-14
Hydraulic Charge Filter Remove and Install .....	21-2160-15
Disassemble and Assemble .....	21-2160-16

*Contents*

## Hydraulic Pump Remove and Install

1. Lower all equipment to ground.
2. Stop engine and relieve hydraulic system pressure.
3. Turn battery disconnect switch to OFF.
4. Drain Hydraulic Reservoir.

### Specification

Hydraulic Reservoir—Capacity.....	32 L
	8.5 gal

5. If equipped with heater, drain engine coolant.

### Specification

Engine Coolant—Capacity.....	11.3 L
	3 gal

6. Remove floor mat and floor access plate.
7. For machines with toolbox, pull out drawer and remove cap screw holding toolbox in place. Remove toolbox from machine.
8. Remove four cap screws (A).
9. Remove shoulder cap screws (C) from seat box under armrest (B) on both sides of seat.
10. Remove two cap screws from knee pad (E) on both sides of seat.
11. Tilt seat up as far as possible with jack screw (D) located in left rear corner of seat box.

A—Cap Screw (4 used)      D—Jack Screw  
 B—Armrest                      E—Knee Pad  
 C—Shoulder Cap Screw (2 used)



Seat Base Cap Screws

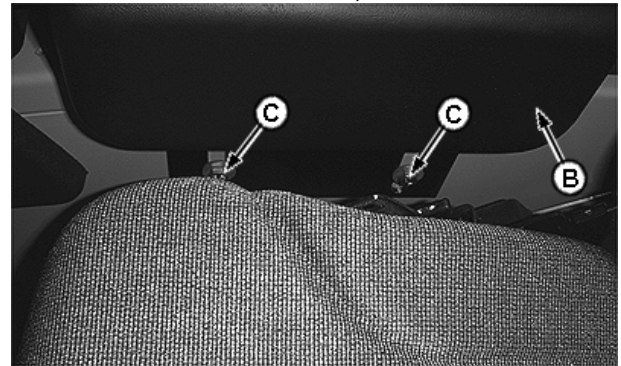

Seat Armrest Cap Screws



Jack Screw

KV70328,000007C -19-06DEC06-1/3

12. Disconnect blower harness connector (1) and heater hoses (2 and 3)
13. Remove heater assembly, If equipped.

1— Blower Harness Connector    3— Heater Hose  
 2— Heater Hose

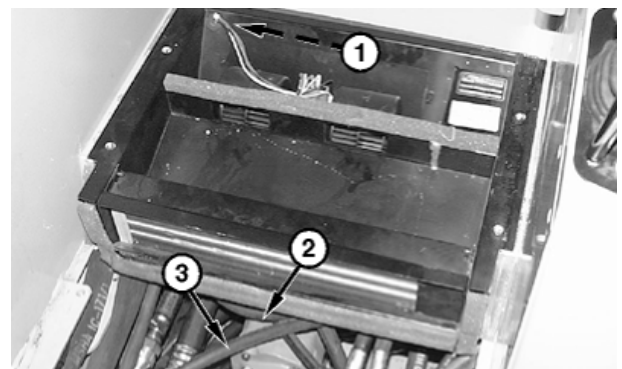

Heater

Continued on next page

KV70328,000007C -19-06DEC06-2/3

14. Disconnect hoses (1 and 2). Cap and plug all openings
15. Install a cap screw and large washer on end of DFT1132 Hydrostatic Motor and Hydraulic Pump Removal and Installation tool (4). Install lifting straps around pump.

**CAUTION:** Prevent possible crushing injury from removing hydraulic pump. Use proper lifting equipment and safety precautions.

**Hydraulic Pump—Specification**

Hydraulic Pump—Weight.....	23 kg
	51 lb

16. Remove cap screws (3) and carefully remove hydraulic pump from left side of machine.
17. Install hydraulic pump and tighten cap screws to specifications.

**Hydraulic Pump—Specification**

Hydraulic Pump Mounting	
Cap Screws—Torque.....	140 N·m
	103 lb-ft

18. Connect hydraulic pump-to-reservoir and hydraulic pump-to-control valve inlet hydraulic hoses (1 and 2).
19. Return any hoses moved for access to original position and install tie bands.
20. Install heater and connect heater hoses, if equipped.
21. Lower seat and secure floor plate.
22. Install tool box, knee pads, and armrests.
23. Install floor access plate and floor mat.
24. Fill hydraulic reservoir. See Transmission and Hydraulic Oil. (Operator's Manual.)

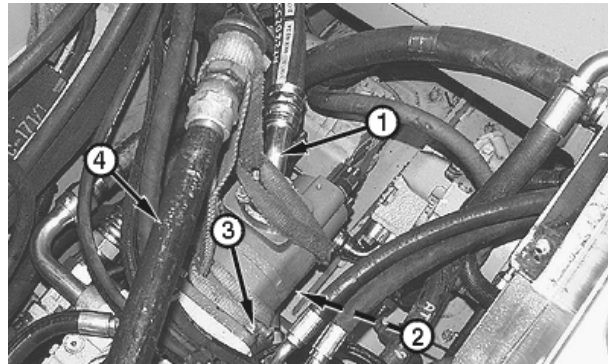

Hydraulic Pump

T119661B—UN—19JAN09

- |   |   |
|---|---|
| 1— Hydraulic Pump-to-Reservoir Hydraulic Hose           | 3— Cap Screws (4 used)  |
| 2— Hydraulic Pump-to-Control Valve Inlet Hydraulic Hose | 4— DFT1132 Hydrostatic Motor and Hydraulic Pump Removal and Installation tool |

**Hydraulic Pump—Specification**

Hydraulic Reservoir—Capacity.....	32 L
	8.5 gal

25. Fill radiator with coolant. See Diesel Engine Coolant. (Operator's Manual.)

**Hydraulic Pump—Specification**

Engine Coolant—Capacity.....	11.3 L
	3 gal

26. Turn battery disconnect switch to ON.
27. Operate machine and check for leaks.

KV70328,000007C -19-06DEC06-3/3

### Hydraulic Pump (With Winch Option) Disassemble and Assemble

1. Remove retainer ring (2) and seal retainer (1).

*NOTE: For replacement of input shaft seals (4—5) perform steps 1—4 only.*

2. Remove seals (4 and 5).
3. Install seal (4) flush with face of recess in housing with lip toward gear.
4. Install seal (5) flush with counterbore seal in seal retainer (1) with lip away from gear.
5. Install O-ring (3) on seal retainer and apply petroleum jelly to lip of seals and O-ring. Install seal retainer and retainer ring.

1— Seal Retainer  
2— Retainer Ring  
3— O-Ring

4— Seal  
5— Seal

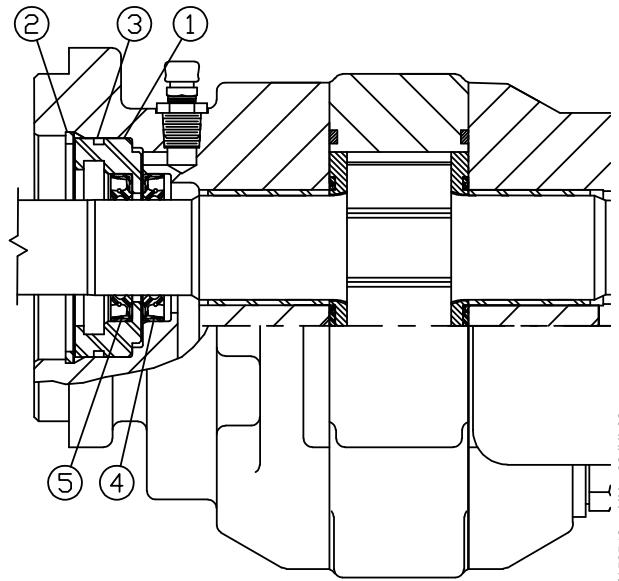

Pump Seal Assembly

T156546 —UN—02JUL02

Continued on next page

TX.3260,SS2327 -19-16NOV06-1/4

## Hydraulic System

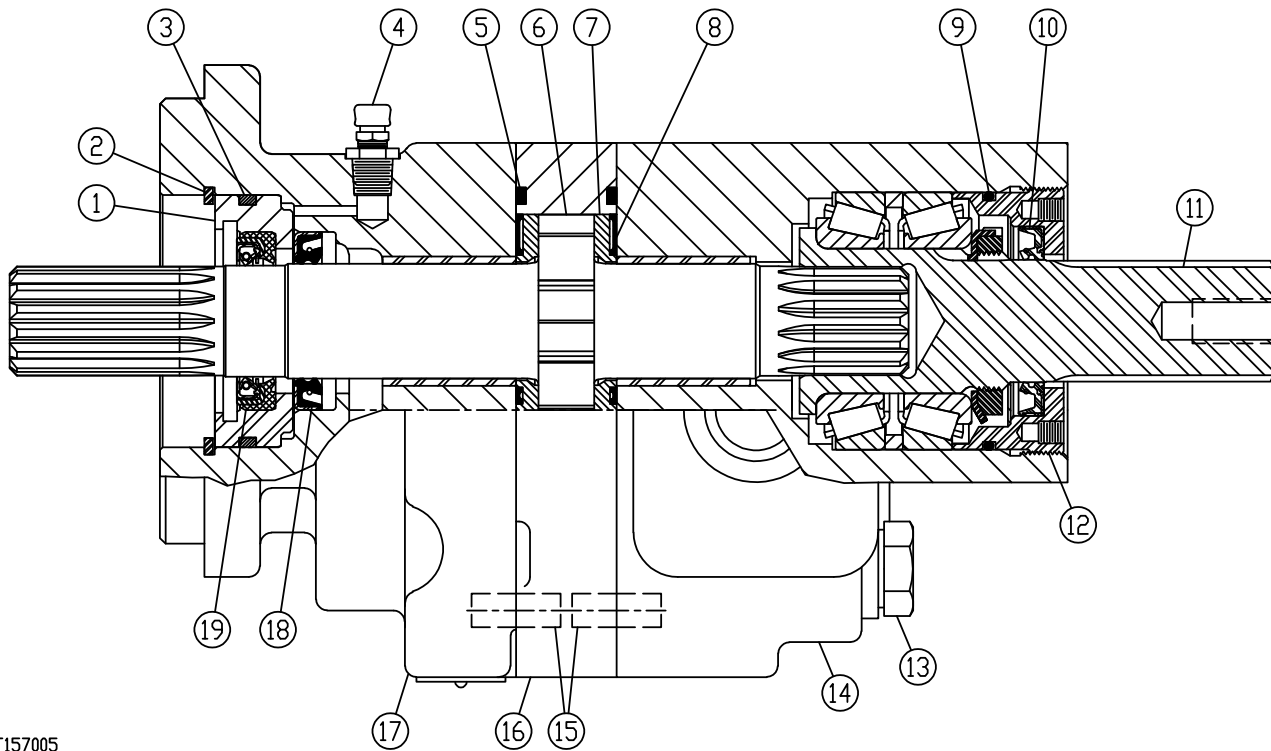

T1157005

Pump with Winch

T1157005—UN—08JUL02

- |  |   |   |   |
|--|---|---|---|
| <p>1— Seal Retainer<br/>2— Retainer Ring<br/>3— O-Ring<br/>4— Vent<br/>5— Square Seal (2 used)</p> | <p>6— Gear Shaft Set<br/>7— Thrust Plate (2 used)<br/>8— Channel Seal (2 used)<br/>9— O-Ring<br/>10— Seal</p> | <p>11— Stub Shaft Assembly<br/>12— Threaded Seal Retainer<br/>13— Cap Screw<br/>14— Stub Shaft Housing<br/>15— Alignment Pin (4 used)</p> | <p>16— Gear Housing<br/>17— Front Housing<br/>18— Seal<br/>19— Seal</p> |
|--|---|---|---|

6. Put a mark across housings (14, 16 and 17) to aid in assembly.

**IMPORTANT:** The assembly of gear shaft set, thrust plates, and channel seals are important. For correct reassembly identify location of parts.

7. Remove cap screws, nuts and washers and separate housings. Remove gear shaft set (6) and thrust plates (7).

*NOTE: Gear shaft set, and pump housings are not serviceable. If any of these parts are worn or damaged, replace pump.*

Continued on next page

TX.3260,SS2327 -19-16NOV06-2/4

8. Remove set screws (1) from stub shaft housing (4).
9. Remove stub shaft retainer (3) from stub shaft housing (4).
10. Remove stub shaft assembly (2) from stub shaft housing (4) using a spanner wrench.

*NOTE: Stub shaft assembly is not serviceable. If worn or damaged, replace.*

11. Inspect parts for wear or damage. Replace parts as necessary.
12. Replace seal (5) and O-ring (6) on stub shaft retainer (3).

1— Set Screws (2 used)  
2— Stub Shaft Assembly  
3— Stub Shaft Retainer

4— Stub Shaft Housing  
5— Seal  
6— O-Ring

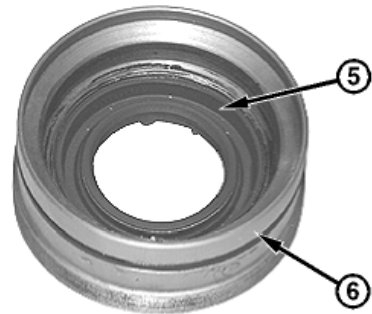
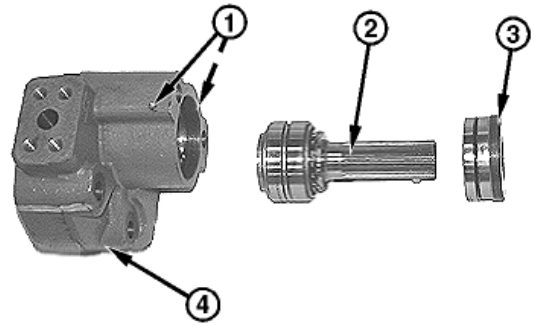

T118260B —UN—07JAN99

T119316B —UN—07JAN99

Continued on next page

TX,3260,SS2327 -19-16NOV06-3/4

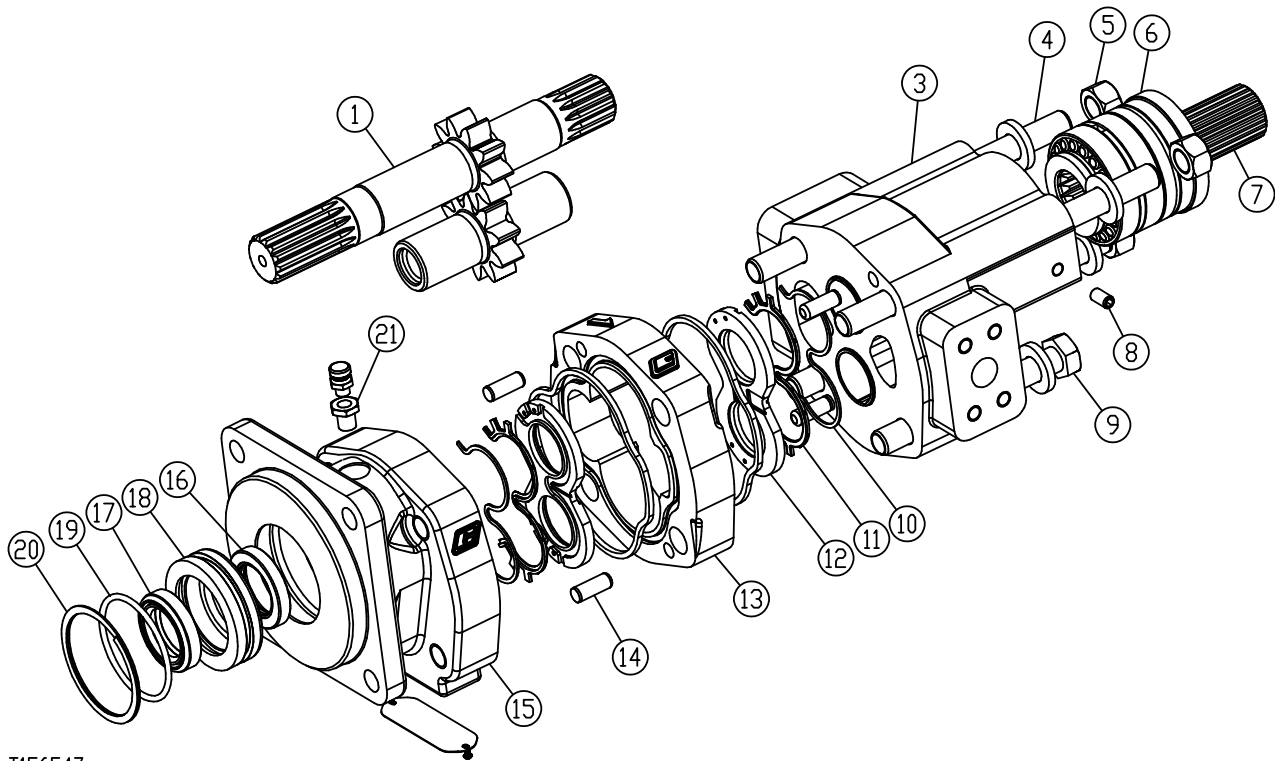

T156547

Hydraulic Pump with Winch

- |                        |                           |                            |                   |
|------------------------|---------------------------|----------------------------|-------------------|
| 1— Matched Gear Set    | 7— Stub Shaft Assembly    | 12— Thrust Plate (2 used)  | 17— Seal          |
| 3— Stub Shaft Housing  | 8— Set Screw (2 used)     | 13— Center Gear Housing    | 18— Seal Retainer |
| 4— Stud (3 used)       | 9— Cap Screw              | 14— Alignment Pin (4 used) | 19— O-Ring        |
| 5— Nut (6 used)        | 10— Backing Seal (2 used) | 15— Lower Gear Housing     | 20— Retainer Ring |
| 6— Stub Shaft Retainer | 11— Channel Seal (2 used) | 16— Seal                   |                   |

13. Apply clean hydraulic oil on all internal parts.
14. Install stub shaft assembly (7) in stub shaft housing (3), seating the bearing in the bottom of housing.
15. Install stub shaft retainer (6) in housing and tighten so there is no end play on stub shaft assembly (7).
16. Install and tighten set screws (8).
17. Install matched gear set (1) in center housing (13).
18. Install channel seals (11) in thrust plates (12). Install backing seals (10) into step of channel seals (11).
19. Install thrust plate and seal assemblies on the matched gear set with the seals facing away from the gear and sealing toward the pressure side of the pump as shown above.

20. Assemble center gear housing (13) and lower gear housing (15).
21. Assemble stub shaft housing (3) to center and lower gear housings.
22. Install studs with nuts and cap screws. Tighten cap screws to specifications.

**Hydraulic Pump—Specification**

Hydraulic Pump	
Housing Studs and	
Cap Screws (With Winch	
Option)—Torque.....	271 N·m
	200 lb·ft

TX,3260,SS2327 -19-16NOV06-4/4

T156547 —UN—02JUL02

### Hydraulic Pump (Without Winch Option) Disassemble and Assemble

1. Remove retaining ring (2) and seal retainer (1).
2. Remove seals (4 and 5).
3. Install seal (4) flush with face of recess in housing with lip toward gear.
4. Install seal (5) flush with counterbore seal in retainer (1) with lip away from gear.
5. Install O-ring (3) on seal retainer and apply petroleum jelly to lip of seals and O-ring. Install seal retainer (1) and retaining ring (2).

- |                   |         |
|-------------------|---------|
| 1— Seal Retainer  | 4— Seal |
| 2— Retaining Ring | 5— Seal |
| 3— O-Ring         |         |

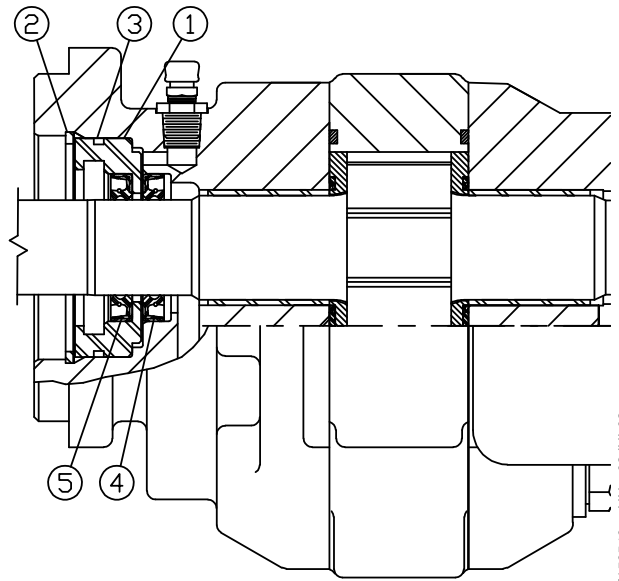

Pump Seal Assembly

Continued on next page

CED,OUTX782,567 -19-16NOV06-1/2

## Hydraulic System

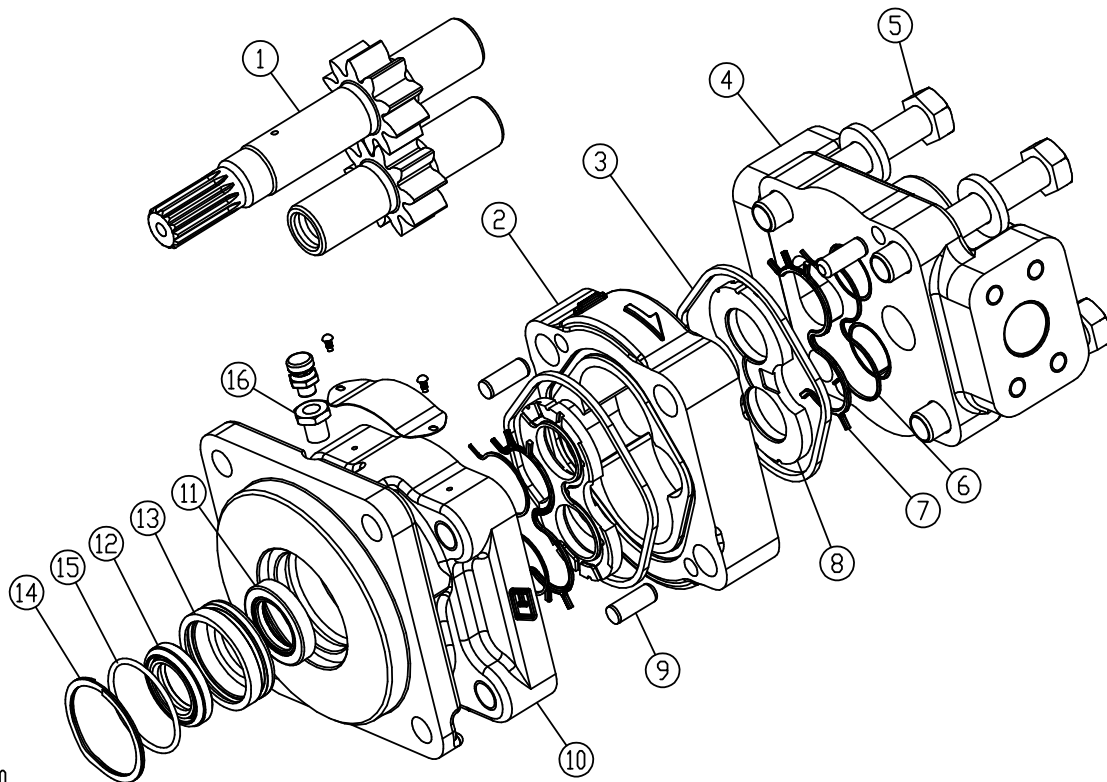

T156550

Hydraulic Pump Assembly

T156550 —UN—02JUL02

- |  |  |  |
|--|--|--|
| <p>1— Matched Gear Set<br/>                 2— Center Gear Housing<br/>                 3— Gasket Seal (2 used)<br/>                 4— Upper Gear Housing</p> | <p>5— Cap Screw (4 used)<br/>                 6— Backing Seal (2 used)<br/>                 7— Channel Seal (2 used)<br/>                 8— Thrust Plate (2 used)</p> | <p>9— Alignment Pin (4 used)<br/>                 10— Lower Gear Housing<br/>                 11— Seal<br/>                 12— Seal</p> |
| <p>13— Seal Retainer<br/>                 14— O-ring<br/>                 15— Retainer Ring</p>  |  |  |

6. Put a mark across housings (2, 4 and 10) to aid in assembly.
7. Remove cap screws and washers. Separate housings.
8. Remove matched gear set (1) and thrust plates (8) with seals (6 and 7).

*NOTE: Pump parts (1, 2, 4, 8 and 10) are not serviceable. If any of these parts are worn or damaged, replace pump.*

9. Inspect parts for wear or damage. Replace parts as necessary.
10. Apply clean hydraulic oil on all internal parts.
11. Install matched gear set (1) in center gear housing (2).
12. Install channel seals (7) in thrust plates (8). Install backing seals (6) into step of channel seals.

13. Install thrust plate (8) and seal assemblies on the matched gear set (1) with the seals facing away from the gear and sealing toward the pressure side of the pump as shown above.
14. Assemble center gear housing (2) and lower gear housing (10).
15. Install upper gear housing and cap screws. Tighten cap screws to specifications.

### Hydraulic Pump—Specification

Hydraulic Pump Housing	
Cap Screws (Without	
Winch Option)—Torque.....	271 N·m
	200 lb·ft

CED,OUTX782,567 -19-16NOV06-2/2

### Hydraulic Reservoir Remove and Install

1. Remove ROPS or cab. See Cab or ROPS Remove and Install. (Group 1800.)
2. Drain reservoir.

**Specification**

Hydraulic  
 Reservoir—Capacity..... 32 L  
 8.5 gal

3. Disconnect control valve-to-hydraulic oil filter return hose (2), hydraulic oil filter restriction indicator lead (3), and reservoir-to-hydraulic pump suction hose (5).
4. Remove hydraulic oil filter (1) and primary fuel filter (4) with hoses attached and set aside.
5. Disconnect control valve linkages (6), starting aid wire connector (9), and starting aid tube (10).
6. Remove bracket and starting aid solenoid (8).
7. Remove control valve (7) with hoses attached and set aside.
8. Remove control levers, linkage, and bellcrank.

- |  |  |
|--|--|
| 1— Hydraulic Oil Filter                              | 6— Control Valve Linkages                          |
| 2— Control Valve-to-Hydraulic Oil Filter Return Hose | 7— Control Valve                                   |
| 3— Hydraulic Oil Filter Restriction Indicator Lead   | 8— Bracket and Starting Aid Solenoid (if equipped) |
| 4— Primary Fuel Filter                               | 9— Starting Aid Wire Connector (if equipped)       |
| 5— Reservoir- to-Hydraulic Pump Suction Hose         | 10— Starting Aid Tube (if equipped)                |

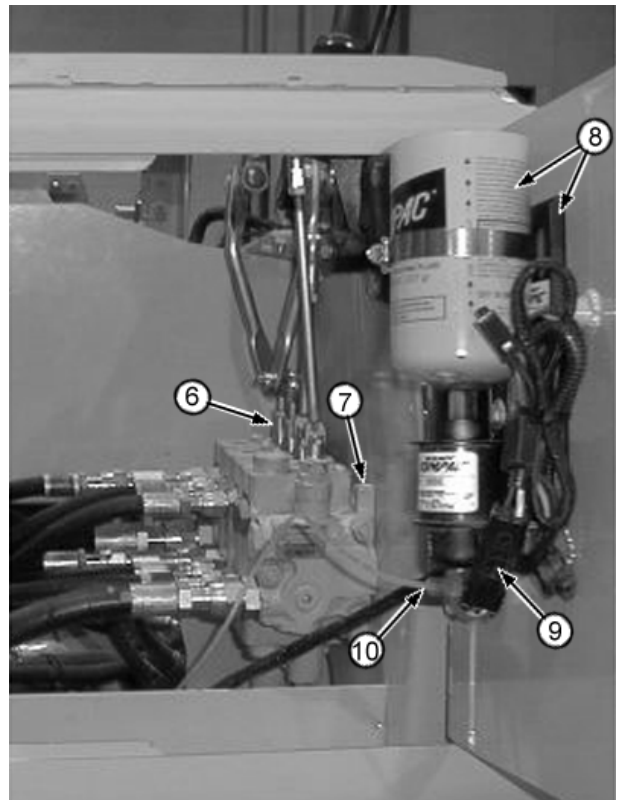
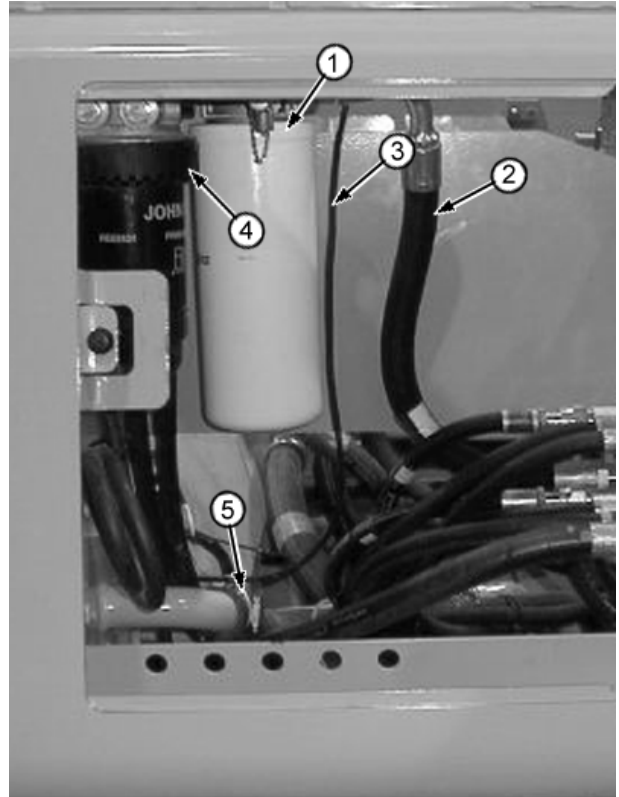

T117730B —UN—12OCT98

T117731B —UN—12OCT98

Continued on next page

CED, TX03768, 2521 - 19-15JUN06-1/4

## Hydraulic System

9. Attach chain and hoist to reservoir.

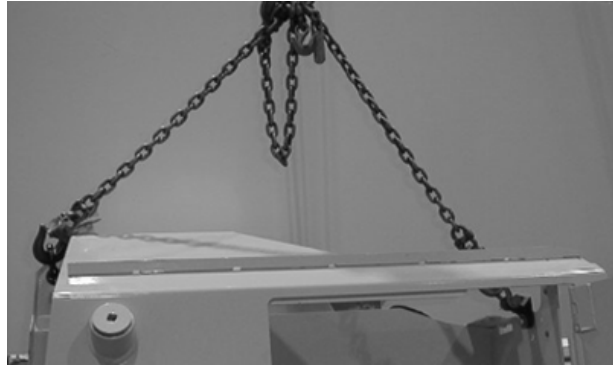

T118032B —UN—26OCT98

CED, TX03768, 2521 -19-15JUN06-2/4

**⚠ CAUTION:** Prevent possible crushing injury from removing hydraulic reservoir. Use proper lifting equipment and safety precautions.

### Hydraulic Reservoir—Specification

Hydraulic Reservoir—Weight.....	102 kg 225 lb
---------------------------------	------------------

10. Remove cap screws (1—4).

11. Install reservoir. Tighten cap screws (1—4) to specification.

### Hydraulic Reservoir—Specification

Hydraulic Reservoir-to-Main Frame Cap Screws—Torque.....	319 N·m 235 lb·ft
--	----------------------

Fuel Tank Bracket-to-Hydraulic Reservoir Cap Screw—Torque.....	244 N·m 180 lb·ft
--	----------------------

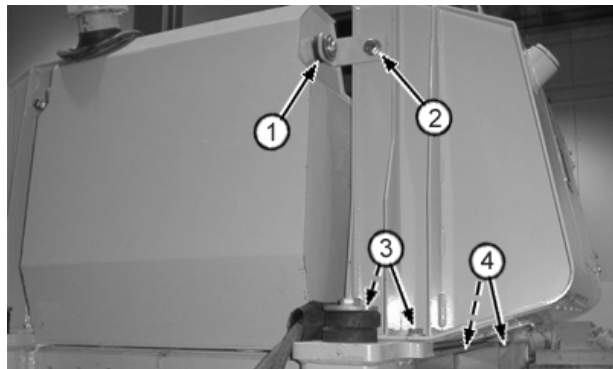

T118062B —UN—26OCT98

**1— Cap Screw  
2— Cap Screw**

**3— Cap Screw (2 used)  
4— Cap Screw (2 used)**

Bracket-to-Isolator-to-Fuel Tank Cap Screws—Torque.....	87 N·m 64 lb·ft
---	--------------------

Continued on next page

CED, TX03768, 2521 -19-15JUN06-3/4

## Hydraulic System

12. Install control valve, control valve levers and linkage and bellcrank (4).
13. Install bracket, solenoid, and tube (5), hydraulic filter (7) and water separator (1). Tighten cap screws to specification.

### Hydraulic Reservoir—Specification

Hydraulic Filter Nuts-to-Studs on Hydraulic Reservoir—Torque.....	31 N·m 23 lb·ft
---	--------------------

14. Connect hydraulic filter restriction indicator lead (2), hydraulic filter hose (3), and reservoir hose (6).
15. Install cab or ROPS. See Cab or ROPS Remove and Install. (Group 1800.)
16. Fill hydraulic reservoir to specification.

### Specification

Hydraulic Reservoir—Capacity.....	32 L 8.5 gal
-----------------------------------	-----------------

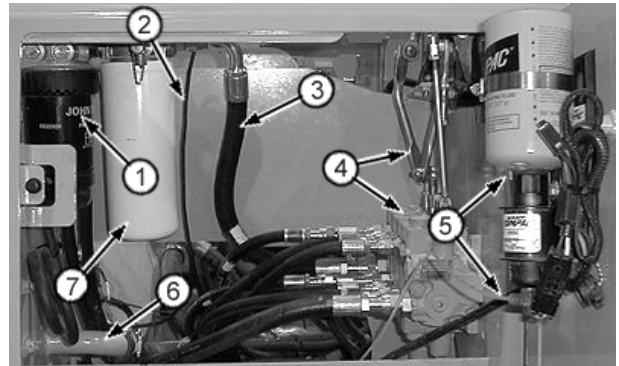

- |   |   |
|---|---|
| 1— Water Separator                              | 5— Bracket, Solenoid and Tube (if equipped) |
| 2— Hydraulic Filter Restriction Indicator Lead  | 6— Reservoir Hose                           |
| 3— Hydraulic Filter Hose                        | 7— Hydraulic Filter                         |
| 4— Control Valve, Levers, Linkage and Bellcrank |   |

T118036B —UN—26OCT98

CED, TX03768, 2521 -19-15JUN06-4/4

### Hydraulic Reservoir and Hydrostatic Reservoir Cleanout Cover Remove and Install

1. Drain reservoir. See Change Hydraulic Oil and Filter or see Change Transmission Oil and Filter. (Operator's Manual.)
2. Remove components as necessary to access cleanout cover.

**IMPORTANT: Prevent fluid contamination. Remove paint and debris from sealing edge of cleanout cover prior to removal.**

3. Remove paint from sealing edge of hydraulic reservoir cleanout cover (3).

*NOTE: Do not fully remove cap screw (2) from inner plate.*

4. Loosen cap screw (2) enough to remove cleanout cover assembly.

**IMPORTANT: Avoid fluid contamination. Paint may be chipped if cleanout cover drops into reservoir. Clean all debris from reservoir before installing cleanout cover.**

5. Inspect gasket and cover plates for any cuts or loose material that could lead to contamination. Repair or replace parts as necessary.

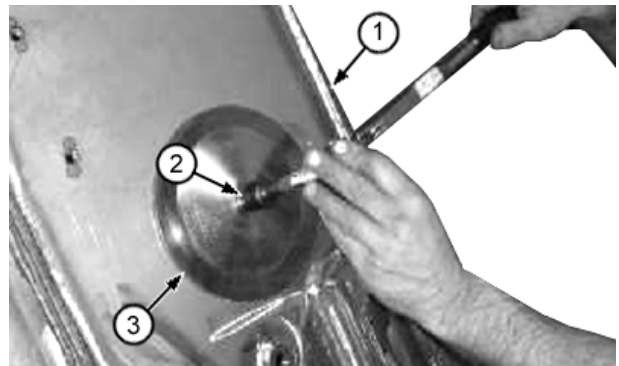

*Hydraulic Reservoir Cleanout Cover*

- |                        |                                       |
|------------------------|---------------------------------------|
| 1— Hydraulic Reservoir | 3— Hydraulic Reservoir Cleanout Cover |
| 2— Cap Screw           |                                       |

**IMPORTANT: Avoid fluid contamination. Do not allow paint or debris to enter reservoir. Thoroughly clean if debris enters reservoir.**

6. Inspect and remove paint buildup and debris from reservoir exterior wall.

Inspect locator tabs in reservoir to verify that they are perpendicular to reservoir wall.

Continued on next page

JW40272,00004E3 -19-27AUG09-1/4

T197423A —UN—02FEB04

**NOTE:** Cap screw should turn into weld nut without resistance. If resistance is felt, inspect weld nut for debris in threads and clean as necessary.

**NOTE:** Avoid possible fluid leak. Verify O-ring is installed under head of cap screw before assembly.

- Loosely assemble cleanout cover with gasket and inner plate.

**NOTE:** To ease installation, do not thread cap screw all the way into weld nut. Orient as shown.

4— Inner Plate Tab

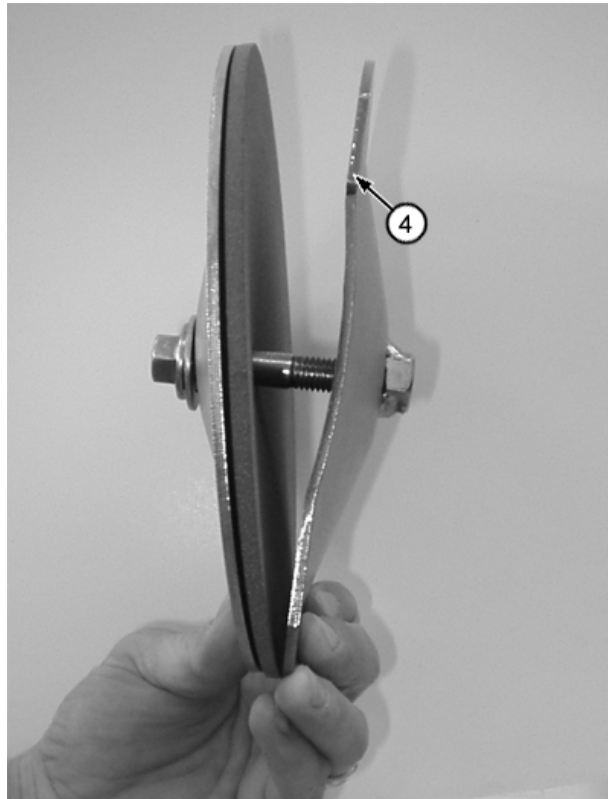

T198245B —UN—02MAR04

JW40272.00004E3 -19-27AUG09-2/4

**IMPORTANT:** To prevent damage to the inner plate, the inner plate must seat flush against reservoir wall. Damage will result to locator tabs (5 and 6) if inner plate is installed incorrectly.

**NOTE:** Install inner plate with inner plate tabs (4) facing toward top of reservoir. Inner plate must be located between upper (5) and lower (6) locator tabs.

- Install cleanout cover assembly starting with one corner of inner plate upper tabs.

Rest one tab of inner plate on upper locator tab (5) and rotate inner plate around until entirely inside reservoir. Pull back on cap screw to seat inner plate against reservoir wall **between** upper and lower locator tabs (5 and 6).

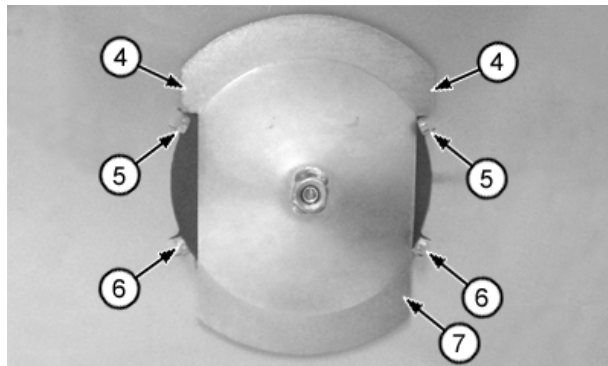

Tab Location View Inside Reservoir

4— Inner Plate Tab (2 used)      6— Lower Locator Tab (2 used)  
5— Upper Locator Tab (2 used)      7— Inner Plate

T198238B —UN—02MAR04

Continued on next page

JW40272.00004E3 -19-27AUG09-3/4



### Hydraulic Reservoir Disassemble and Assemble

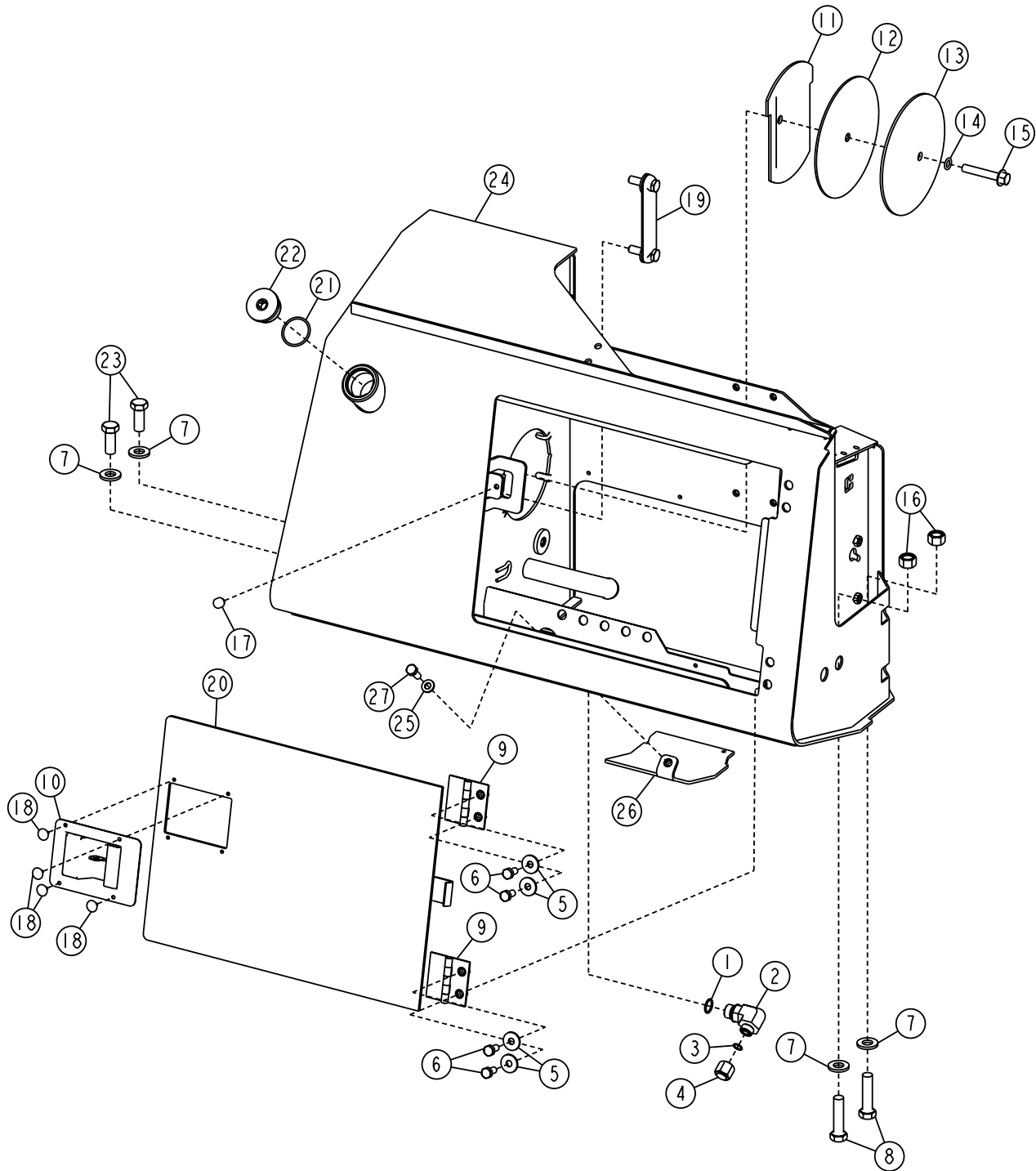

TX1062875

Hydraulic Reservoir

TX1062875 —UN—18AUG09

Continued on next page

CED.TX03768.2522 -19-20AUG09-1/2

## Hydraulic System

1— O-Ring 2— Elbow Fitting 3— O-Ring 4— Plug 5— Washer (4 used) 6— Cap Screw (4 used) 7— Washer (4 used)	8— Cap Screw (2 used) 9— Hinge (2 used) 10— Latch 11— Inner Plate 12— Gasket 13— Cleanout Cover 14— O-Ring	15— Cap Screw 16— Nut (2 used) 17— Grommet 18— Rivet (4 used) 19— Level Gauge 20— Door 21— O-Ring	22— Plug 23— Cap Screw (2 used) 24— Reservoir 25— Washer 26— Access Cover Plate 27— Cap Screw
--	--	---	--

Item	Measurement	Specification
Hydraulic Reservoir		
Reservoir Cleanout Cover Cap Screw	Torque	47 N·m 35 lb.-ft.

CED, TX03768, 2522 -19-20AUG09-2/2

### Hydraulic Filter Remove and Install

1. Open right side access door
2. Loosen oil fill plug on reservoir to release pressure
3. Disconnect hoses (1 and 3) and hydraulic filter wiring lead (4).
4. Remove cap screws (2) and remove hydraulic filter
5. Install hydraulic filter
6. Connect hoses (1 and 3) and hydraulic filter wiring lead (4).

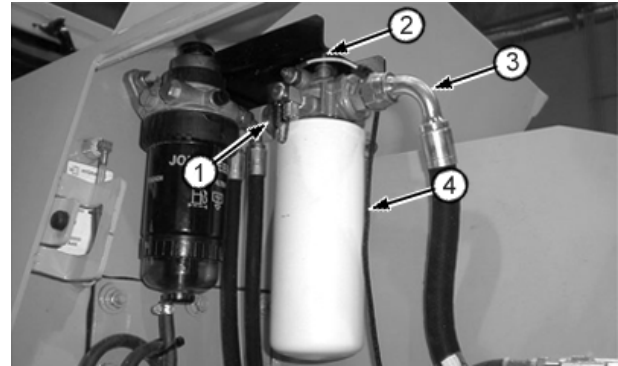

*Hydraulic Filter*

- |   |   |
|---|---|
| 1— Hydraulic Filter-to-Hydraulic Reservoir Hose | 3— Control Valve-to-Hydraulic Filter Hose |
| 2— Cap Screw (4 used)                           | 4— Hydraulic Filter Wiring Lead           |

T118063B —JUN—26OCT98

KV70328,000007E -19-14JUN06-1/1

### Hydraulic Filter Disassemble and Assemble

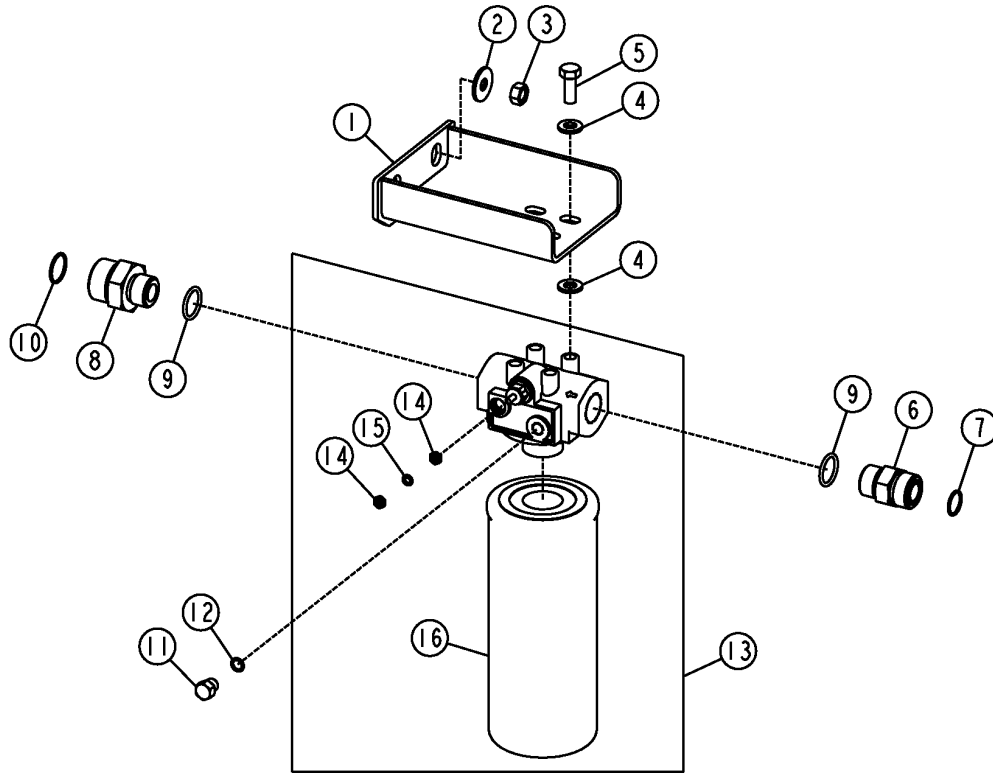

Hydraulic Filter

- |                    |                       |                    |                      |
|--------------------|-----------------------|--------------------|----------------------|
| 1— Bracket         | 5— Cap Screw (4 used) | 9— O-Ring (2 used) | 13— Filter Head      |
| 2— Washer (2 used) | 6— Adapter            | 10— O-Ring         | 14— Nut              |
| 3— Nut (2 used)    | 7— O-Ring             | 11— Plug           | 15— Washer           |
| 4— Washer (8 used) | 8— Adapter            | 12— O-Ring         | 16— Hydraulic Filter |

1. Remove and replace parts as needed
2. Tighten nuts (3) and cap screws (5) to specification

Bracket-to-Filter Base	
Cap Screws—Torque.....	50 N·m 37 lb-ft

**Specification**

Filter Mounting	
Bracket-to-Tank Stud	
Nuts—Torque.....	31 N·m 23 lb-ft

KV70328,000007D -19-14JUN06-1/1

T118077—UN—16NOV98

## Section 32 Bulldozer

### Contents

	Page	
<b>Group 3201—Blades</b>		
Blade Remove and Install.....	32-3201-1	
Blade Retainer Split Bearing Installation .....	32-3201-3	
Cutting Edges and End Bits Remove and Install .....	32-3201-4	
<b>Group 3215—Control Linkage</b>		
Hydraulic Control Lever Linkage Remove and Install.....	32-3215-1	
Auxiliary Control Linkage Remove and Install .....	32-3215-3	
<b>Group 3240—Frames</b>		
Dozer C-Frame Remove and Install .....	32-3240-1	
<b>Group 3260—Hydraulic System</b>		
Hydraulic Control Valve Remove and Install .....	32-3260-1	
Disassemble and Assemble.....	32-3260-2	
Wiper Seals and Lip Seals, Replace.....	32-3260-3	
Disassemble and Assemble Auxiliary Section .....	32-3260-9	
Disassemble and Assemble Angle Section.....	32-3260-10	
Disassemble and Assemble Tilt Section .....	32-3260-12	
Disassemble and Assemble Lift Section .....	32-3260-13	
Integrated Grade Control (IGC) Lever Remove and Install (S.N. 130886—).....	32-3260-15	
Integrated Grade Control (IGC) Lever Disassemble and Assemble (S.N. 130886—).....	32-3260-17	
Disassemble and Assemble System Relief Valve.....	32-3260-18	
Cylinders		
Remove and Install Tilt.....	32-3260-19	
Remove and Install Angle .....	32-3260-20	
Remove and Install Lift.....	32-3260-21	
Angle, Lift, and Tilt Cylinders Disassemble and Assemble (John Deere 120 Series Cylinders) .....		32-3260-21

*Contents*

Blade Remove and Install

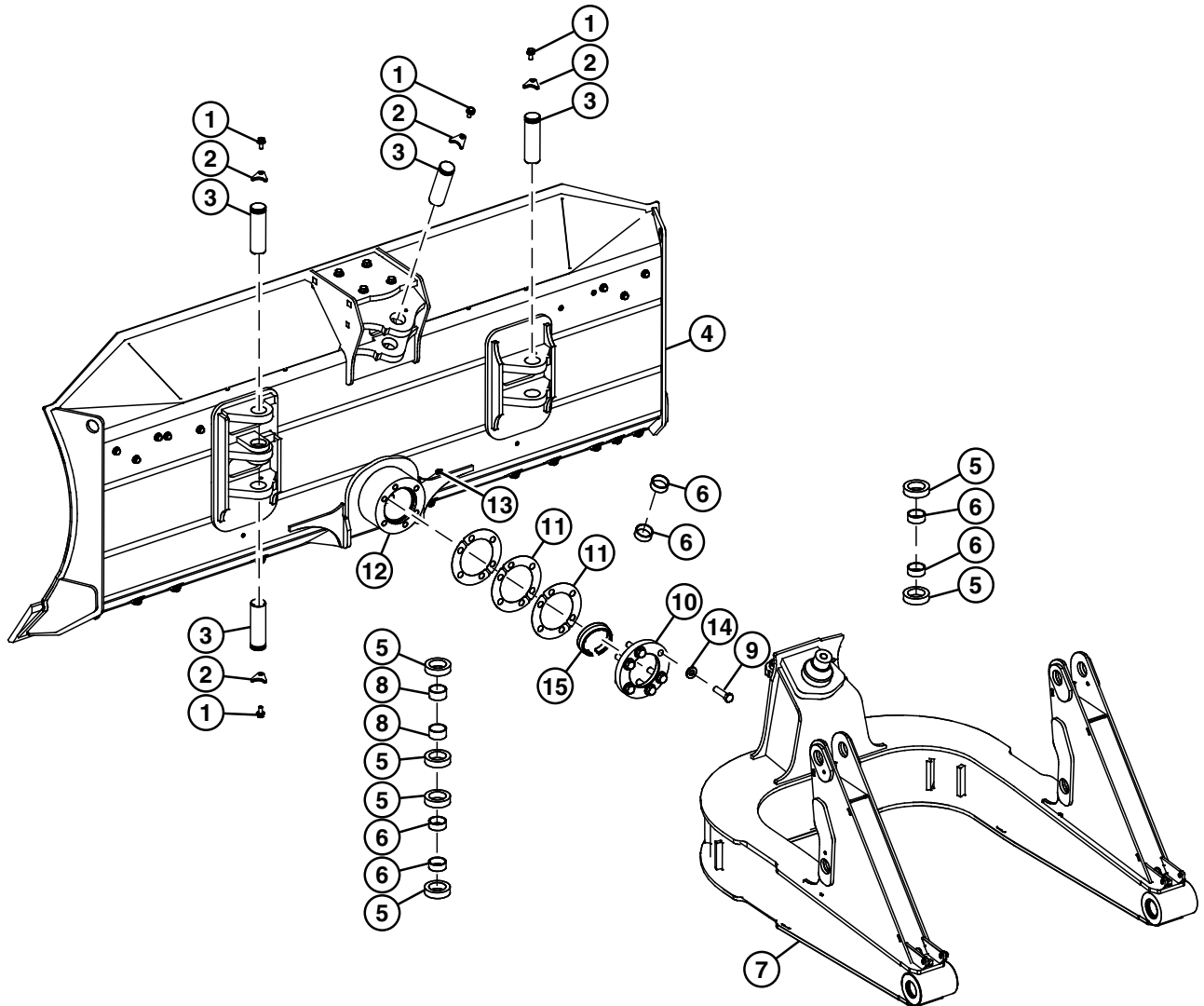

TX1032997

C-Frame and Socket (3 shim)

Continued on next page

KV70328,00002BE -19-04DEC09-1/2

TX1032997 —UN—28FEB08

Blades

- 1— Cap Screw (4 used)
- 2— Retainer Plate (4 used)
- 3— Pin (4 used)
- 4— Blade

- 5— Bushing (8 used)
- 6— Bushing (6 used)
- 7— C-Frame
- 8— Bushing (2 used)

- 9— Cap Screw (6 used)
- 10— Socket Cap
- 11— Shim (3 used)
- 12— Socket

- 13— Lubrication Fitting
- 14— Washer (6 used)
- 15— Split Bearing

There have been multiple shim configurations. If new shims are required the three shim design will retrofit previous configurations.

1. Lower all equipment to the ground.
2. Stop engine and operate control valves to relieve hydraulic system pressure.

**CAUTION: Prevent possible crushing injury. Use proper lifting equipment and safety precautions.**

3. Install appropriate lifting device and apply stabilizing pressure to blade (4).

Specification	
Blade—Weight.....	667 kg 1471 lb

4. Remove both retainer plates (2) and cap screws (1) from tilt cylinder and angle cylinder pins on left side of blade.
5. Remove pin (3) from tilt cylinder head end and remove bushings (5 and 8)
6. Remove pin from angle cylinder rod end and remove bushings (5 and 6)
7. Remove retainer plate and cap screw from angle cylinder pin on right side of blade.
8. Remove pin from angle cylinder rod end and remove bushings.
9. Remove retainer plate and cap screw from pitch link pin at center of blade.
10. Remove pin from pitch link end and remove bushings.

*NOTE: Socket cap remains on ball of C-Frame until split bearing (15) is removed.*

11. Remove six cap screws (9), socket cap (10) and shims (11).

**CAUTION: Prevent possible crushing injury. Use proper lifting equipment and safety precautions.**

12. Using appropriate lifting device remove blade.

Specification	
Blade—Weight.....	667 kg 1471 lb

*NOTE: If split bearing should be replaced see Blade Retainer Split Bearing Installation. (Group 3201.)*

13. Inspect, repair or replace parts as necessary.

**CAUTION: Prevent possible crushing injury. Use proper lifting equipment and safety precautions.**

14. Using appropriate lifting device install blade (4). Leave lifting device attached to stabilize blade while all connections are made.

Specification	
Blade—Weight.....	667 kg 1471 lb

15. Apply clean engine oil to retainer plate cap screw threads.

**IMPORTANT: When installing shims, install the ball socket retainer without shims. Tighten cap screws and measure gap. Install enough shims to fill gap plus one extra shim.**

*NOTE: When tightening cap screws (9) for socket cap (10) to specification, angle blade to maximum pitch on both sides.*

16. Install socket cap (10) without shims and tighten cap screws. Measure gap between ball socket and retainer. Install shims to fill gap and add one shim. Install pivot cap screws (9). Tighten pivot cap screws to hold socket cap and blade in place, but do not tighten to specification.

**IMPORTANT: Grease socket and ball joint every ten hours or daily. Only use grease specified on machines periodic maintenance chart. Add grease until it escapes at joint.**

17. Install bushings (5 and 6), pin (3), retainer plate (2) and cap screw (1) for pitch link. For machines with adjustable pitch linkage see Blade Pitch Linkage Adjustment. (Group 9025-20.)
18. Install bushings, pin, retainer plate and cap screw for angle cylinder rod end on right side of blade.
19. Install bushings, pin, retainer plate and cap screw for angle cylinder rod end on lower left side of blade.
20. Install bushings (5 and 8), pin, retainer plate and cap screw for tilt cylinder head end on upper left side of blade.

21. Remove lifting device

22. Angle blade to maximum pitch to each side, lube and tighten pivot cap screws as specified.

Specification	
Pivot Cap Screws—Torque.....	255 N·m 188 lb-ft

23. Grease all points as specified in operator's manual. See Grease Dozer Linkage and Blade Socket. (Operator's Manual.)

KV70328.00002BE -19-04DEC09-2/2

24. Operate blade through full range of motion for all blade functions to check for binding.

KV70328,00002BE -19-04DEC09-3/2

### Blade Retainer Split Bearing Installation

Use this procedure to install or replace the blade retainer split bearing.

Order AT347280 Blade Retaining Ring Installation tools from service parts if doing this procedure for first time.

1. Install blade pivot retainer (1) on blade pivot ball on C-Frame.

- |                                 |                     |
|---------------------------------|---------------------|
| 1— Blade Pivot Retainer         | 3— Blade Pivot Ball |
| 2— Blade Retainer Split Bearing |                     |

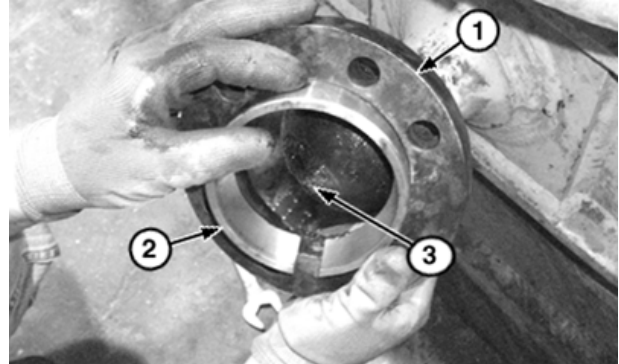

Blade Retainer Split Bearing

KV70328,00002C0 -19-29FEB08-1/2

TX1027253A —UN—07AUG07

2. Install inner installation plate (10) between blade pivot retainer and blade pivot ball (3).
3. Install blade retainer split bearing (2) onto blade pivot ball.
4. Using cap screws (4), washers (6) and nuts (5) install outer installation plate (7).
5. Tighten cap screws evenly until split bearing snaps over pivot ball.
6. Remove nuts, washers, cap screws, outer installation plate and inner installation plate.

- |                       |                                      |
|-----------------------|--------------------------------------|
| 4— Cap Screw (3 used) | 7— T231226 Outer Installation Plate  |
| 5— Nut (3 used)       | 10— T231227 Inner Installation Plate |
| 6— Washer (3 used)    |                                      |

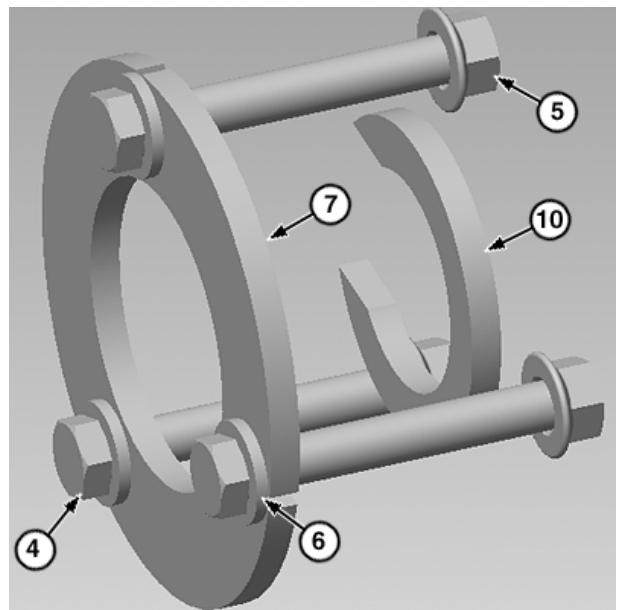

KV70328,00002C0 -19-29FEB08-2/2

TX1029865A —UN—25SEP07

**Cutting Edges and End Bits Remove and Install**

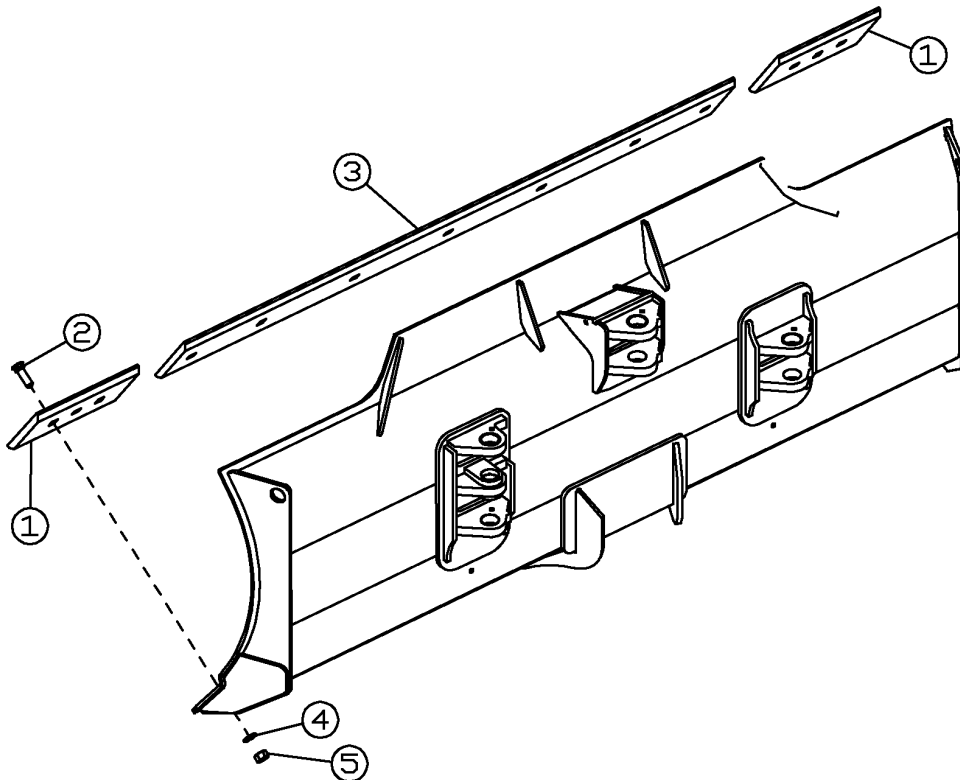

T119374

*Cutting Edge and End Bits 97 in. Blade Shown*

- |                        |                     |                  |
|------------------------|---------------------|------------------|
| 1— End Bit (2 used)    | 3— Cutting Edge     | 5— Nut (13 used) |
| 2— Cap Screw (13 used) | 4— Washer (13 used) |                  |

1. Block frame with cutting edge above ground level.
2. Remove parts (1—5).
3. Inspect parts and replace as necessary.
4. Install parts (1—5). Tighten hardware.

CED,TX03768,2525 -19-10DEC07-1/1

T119374—UN—06/JAN99



Hydraulic Control Lever Linkage Remove and Install

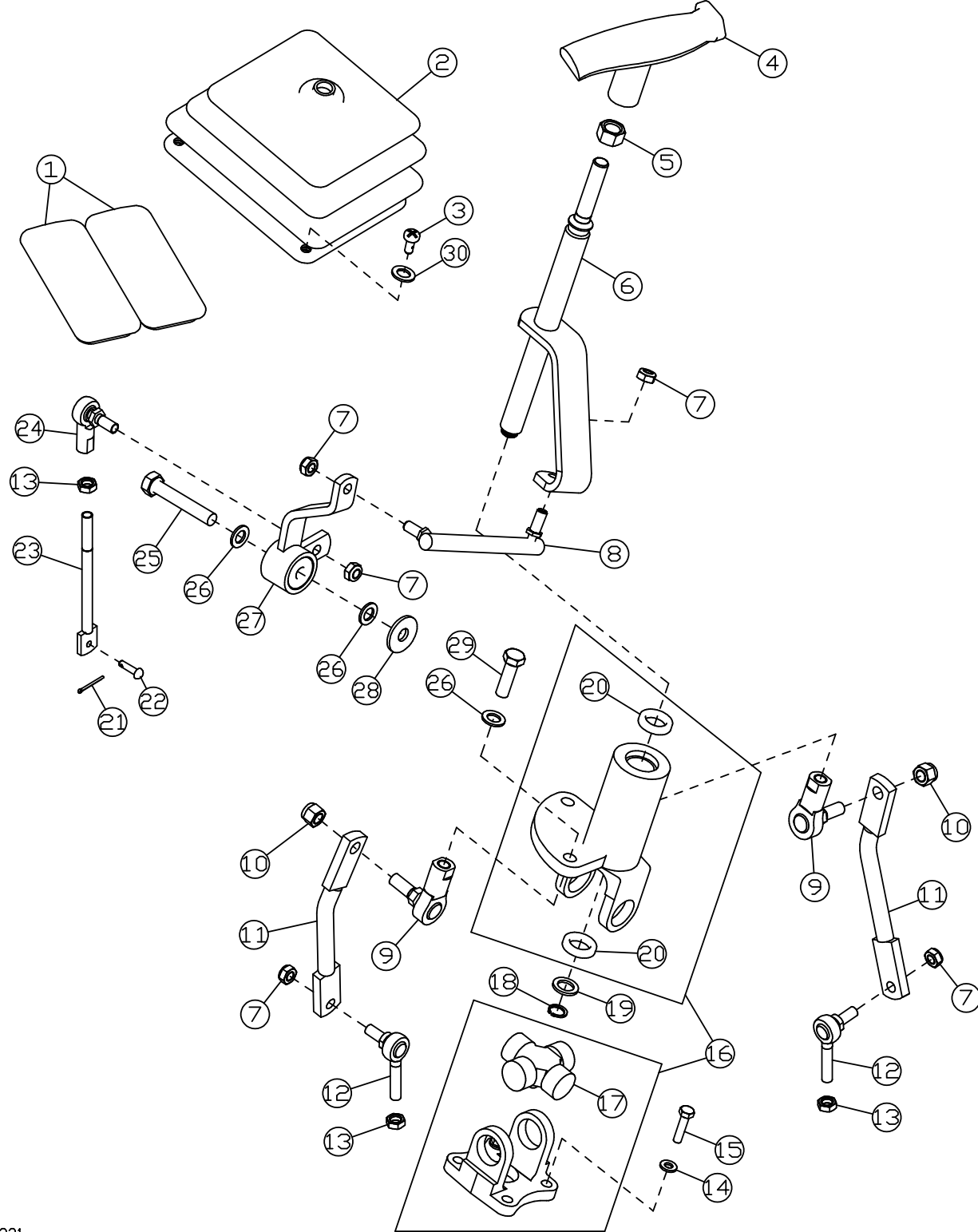

T141321

T141321—UN—07/AUG01

Continued on next page

CED.TX03768.2526 -19-12APR01-1/2

*Control Linkage*

- |   |   |  |  |
|---|---|--|--|
| 1— Grommet (2 used)<br>2— Boot<br>3— Cap Screw (4 used)<br>4— T-Bar Control Handle<br>5— Nut<br>6— Control Shaft<br>7— Lock Nut (5 used)<br>8— Stud Link Ball Joint | 9— Ball Joint (2 used)<br>10— Lock Nut (2 used)<br>11— Tilt Valve and Lift Section Link (2 used)<br>12— Ball Joint (2 used)<br>13— Nut (3 used)<br>14— Washer (4 used)<br>15— Cap Screw (4 used)<br>16— U-Joint Control Housing | 17— U-Joint<br>18— Snap Ring<br>19— Washer<br>20— Bearing (2 used)<br>21— Cotter Pin<br>22— Pin<br>23— Rod-to-Angle Valve Section Link<br>24— Ball Joint | 25— Cap Screw<br>26— Washer (4 used)<br>27— Bellcrank<br>28— Washer<br>29— Cap Screw (2 used)<br>30— Washer (4 used) |
|---|---|--|--|

1. Open access door to control valve.
2. Remove lock nuts (7) on tilt and lift valve ball joints (12).
3. Remove cotter pin (21) and pin (22) on angle valve rod.
4. Remove cap screw (25) and washer (26) from bellcrank (27).
5. Remove cap screws (15) and washers (14) from U-joint assembly.
6. Remove cap screws (3) and boot (2). Remove assembly.
7. Disassemble and assemble parts as required.
8. Tighten cap screws (15).

**T-Bar Control Valve Linkage—Specification**

Mount T-Bar Linkage-to-Hydraulic Tank Cap	
Screws—Torque.....	15 N·m 11 lb·ft

9. Tighten lock nuts (10) to specification.

**T-Bar Control Valve Linkage—Specification**

3/8 Lock Nut—Torque.....	35 N·m 26 lb·ft
--------------------------	--------------------

10. Tighten lock nuts (7) to specification.

**T-Bar Control Valve Linkage—Specification**

5/16 Lock Nut—Torque.....	19 N·m 14 lb·ft
---------------------------	--------------------

11. Adjust T-bar linkage. See Hydraulic Control Lever Linkage Adjustment. (Group 9025-20.)

CED, TX03768, 2526 -19-12APR01-2/2

### Auxiliary Hydraulic Control Lever Linkage Remove and Install

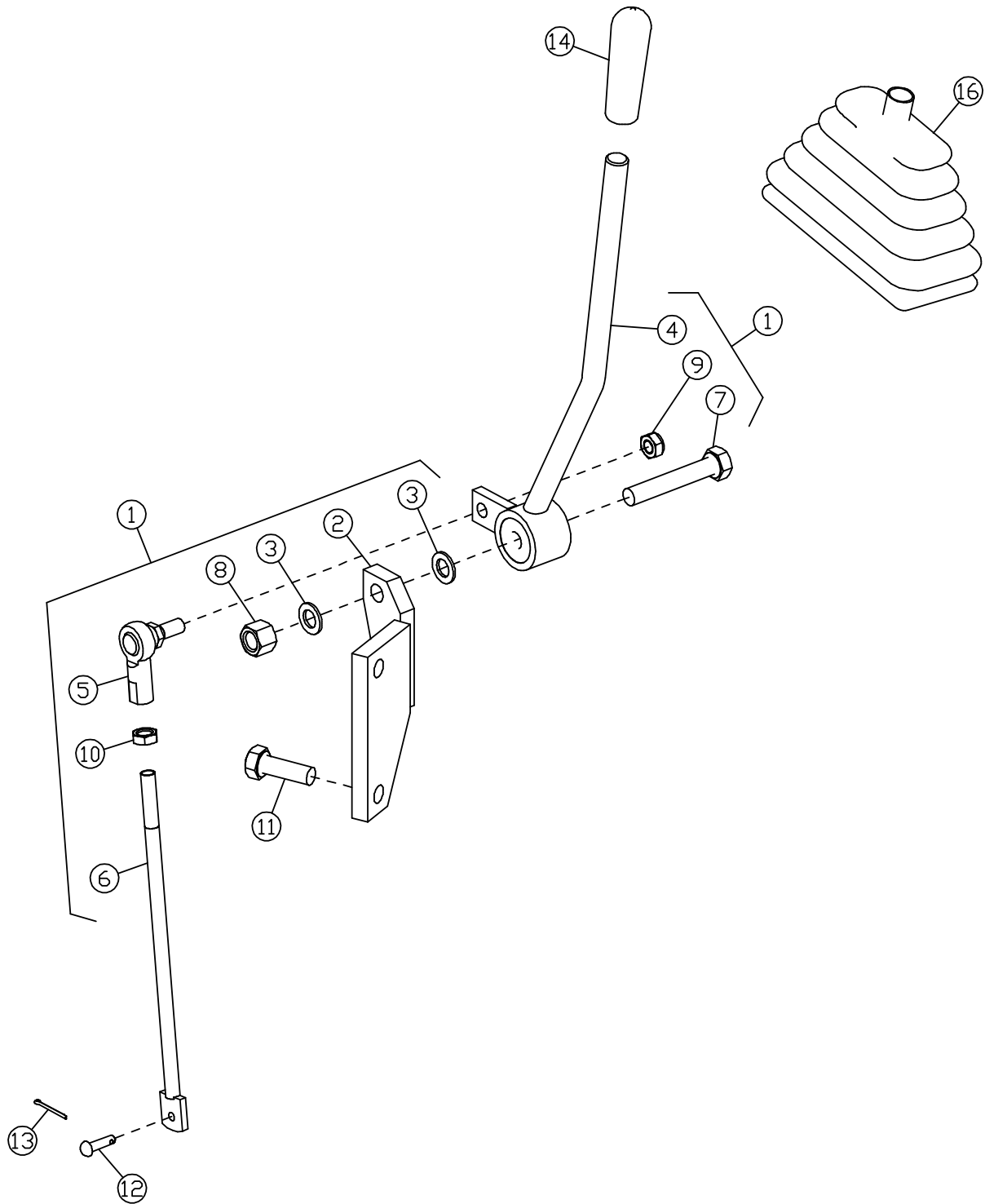

T198500

T198500—UN—16MAR04

Continued on next page

CED,OUTX547,195-19-09APR99-1/2

Control Linkage

1—Control Valve Linkage Assembly  
2—Bracket  
3—Washer  
4—Lever

5—Ball Joint  
6—Rod-to-Auxiliary Valve  
7—Cap Screw  
8—Lock Nut

9—Lock Nut  
10—Nut  
11—Cap Screw (2 used)  
12—Pin

13—Cotter Pin  
14—Grip  
15—Grommet (Not Shown)  
16—Boot

1. Open access cover to control valve.
2. Remove pin (12).
3. Remove cap screw (7).
4. Remove boot (16).
5. Remove auxiliary linkage assembly.
6. Disassemble and assemble parts as required.
7. Install cap screw (7), pin (12), and boot (16). Tighten cap screw (7) to specification.

**Auxiliary Linkage —Specification**

Lever-to-Bracket Cap	
Screw—Torque.....	.50 N·m 37 lb-ft

8. Adjust auxiliary control linkage. See Auxiliary Lever Linkage Adjustment. (Group 9025-20.)

CED,OUTX547,195 -19-09APR99-2/2

*Control Linkage*

## C-Frame Remove and Install

*NOTE: C-Frame can be removed with blade attached.*

1. Lower all equipment to the ground.
2. Stop engine. Operate all controllers to relieve hydraulic system pressure.
3. Remove blade if necessary. See Blade Remove and Install. (Group 3201.)

*NOTE: If equipped with heavy duty grille, remove upper hose guard.*

4. Remove clamp (1).
5. Remove hose guard (2).

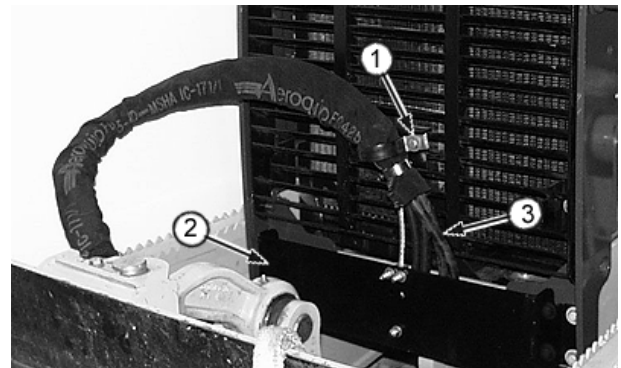

T119392B —UN—07JAN99

1— Hose Clamp  
2— Hose Guard

3— Cylinder Hose (4 used)

BT40170,000001C -19-17JUN02-1/4

**⚠ CAUTION:** Escaping fluid under pressure can penetrate the skin causing serious injury. Avoid the hazard by relieving pressure before disconnecting hydraulic or other lines. Tighten all connections before applying pressure. Search for leaks with a piece of cardboard. Protect hands and body from high pressure fluids.

If an accident occurs, see a doctor immediately. Any fluid injected into the skin must be surgically removed within a few hours or gangrene may result. Doctors unfamiliar with this type of injury should reference a knowledgeable medical source. Such information is available from Deere & Company Medical Department in Moline, Illinois, U.S.A.

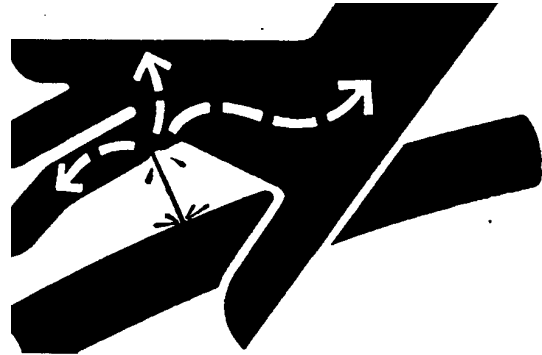

X9811 —UN—23AUG88

6. Disconnect four hoses (3). Cap and plug all openings.

Continued on next page

BT40170,000001C -19-17JUN02-2/4

Frames

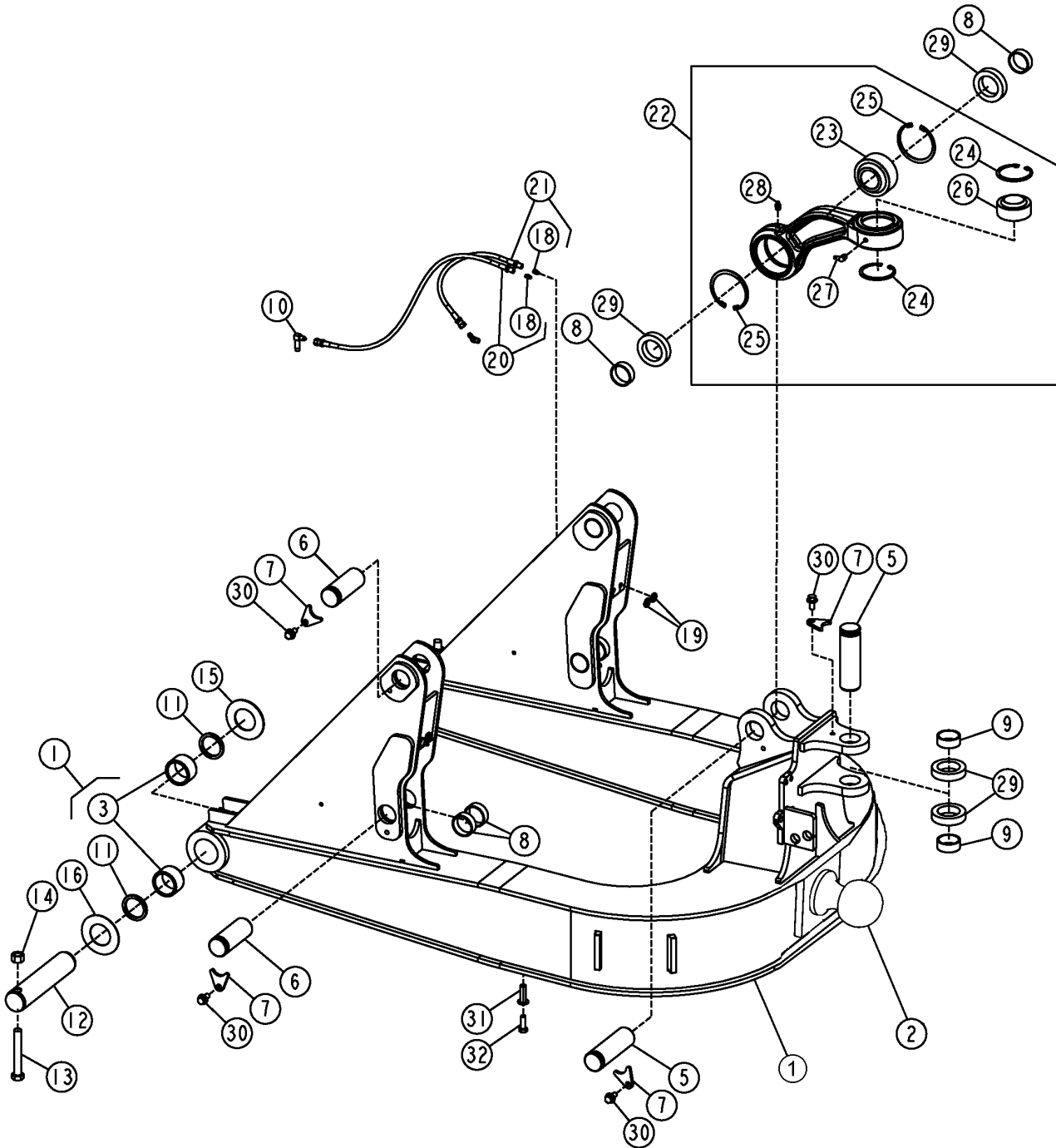

T148206

T148206—UN—19NOV01

Continued on next page

BT40170,000001C -19-17JUN02-3/4

*Frames*

- |                               |                            |                                  |                         |
|-------------------------------|----------------------------|----------------------------------|-------------------------|
| 1— C-Frame                    | 9— Bushing (2 used)        | 17— Not Used                     | 25— Snap Ring (2 used)  |
| 2— Pivot Ball                 | 10— Elbow Fitting (2 used) | 18— Lubrication Fitting (4 used) | 26— Bushing             |
| 3— Bushing (4 used)           | 11— Seal (4 used)          | 19— Nut (4 used)                 | 27— Lubrication Fitting |
| 4— Not Used                   | 12— Pin (2 used)           | 20— Lubrication Hose             | 28— Lubrication Fitting |
| 5— Pin (2 used)               | 13— Cap Screw (2 used)     | 21— Lubrication Hose             | 29— Bushing (4 used)    |
| 6— Lift Cylinder Pin (4 used) | 14— Lock Nut (2 used)      | 22— Strut Support                | 30— Cap Screw (6 used)  |
| 7— Pin Retainer (6 used)      | 15— Washer (2 used)        | 23— Bushing                      | 31— Nut (3 used)        |
| 8— Bushing (6 used)           | 16— Washer (2 used)        | 24— Snap Ring (2 used)           | 32— Cap Screw (3 used)  |

7. Remove lift cylinder pins (6) from rod end of lift cylinders.

**⚠ CAUTION: Prevent possible crushing injury from removing blade. Use proper lifting equipment and safety precautions.**

**C-Frame—Specification**

C-Frame with	
Blade—Weight.....	1040 kg
	2294 lb
C-Frame—Weight.....	375 kg
	826 lb

8. Place chains around C-frame or C-frame and blade. Attach a hoist.
9. Remove pins (12) and remove C-frame or C-frame and blade.
10. Inspect all parts and replace if necessary.
11. Install C-frame, C-frame pins, and lifting cylinder rod end pins.
12. If cylinder hoses were removed, see Hydraulic Component Location. (Group 9025-15.)

BT40170,000001C -19-17JUN02-4/4

*Frames*

## Hydraulic Control Valve Remove and Install

1. Lower all equipment to ground and stop engine.
2. Relieve hydraulic system pressure.
3. Turn battery disconnect switch to OFF.
4. Apply a vacuum to hydraulic reservoir.
5. Disconnect linkage rods (1).
6. Mark and disconnect hoses (9—16). Cap and plug all openings.
7. Remove cap screws (8) and remove control valve.
8. Install control valve using cap screws (8).
9. Connect hoses (9—16).
10. Connect linkage rods (1).
11. Remove vacuum from reservoir.
12. Check and fill hydraulic reservoir as needed.
13. Turn battery disconnect switch to ON.
14. Start machine and check for leaks.

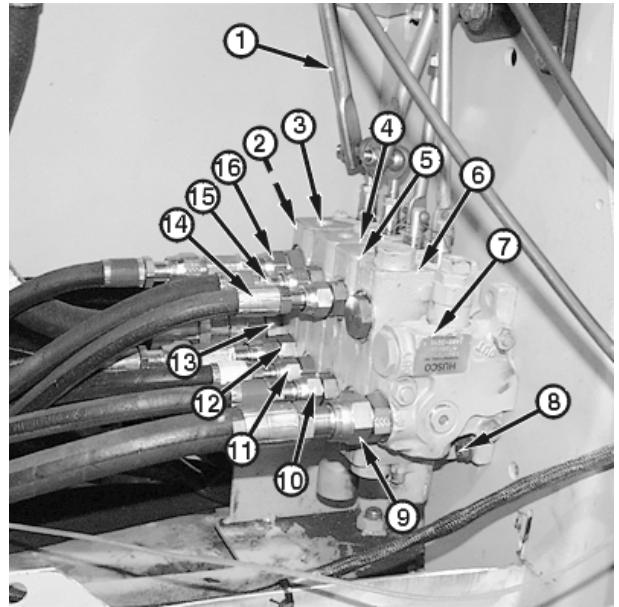

T118949B —UN—15JAN99

- 1— Linkage Rods (4 used)
- 2— Outlet Section
- 3— Lift Section
- 4— Tilt Section
- 5— Angle Section
- 6— Auxiliary Section
- 7— Inlet Section
- 8— Cap Screw (3 used)

- 9— Inlet Valve-to-Hydraulic Pump Hose
- 10— Angle Valve-to-Right Angle Cylinder Rod End and Left Cylinder Head End Hose
- 11— Tilt Valve-to-Tilt Cylinder Head End Hose
- 12— Lift Valve-to-Lift Cylinders Head End Hose
- 13— Outlet Valve-to-Hydraulic Filter Hose
- 14— Angle Valve-to-Left Angle Cylinder Rod End and Right Cylinder Head End Hose
- 15— Tilt Valve-to-Tilt Cylinder Rod End Hose
- 16— Lift Valve-to-Lift Cylinders Rod End Hose

CED, TX03768, 2532 -19-09APR99-1/1

## Hydraulic Control Valve Disassemble and Assemble

**IMPORTANT: Keep all components for each valve section together as a set.**

1. To aid in assembly, identify each section with a mark.
2. Place valve in a vertical position having the inlet section down and supported by wood blocks.
3. Remove nuts (8) and tie rods (7).
4. Carefully remove sections (1—6). Do not lose or damage O-rings (11), load checks (10), and springs (9). Keep load checks and valve sections together as a set.

**IMPORTANT: Use care not to damage or score mating surfaces of valve sections.**

5. Inspect O-rings between each section for wear or damage. Replace as necessary.
6. Inspect springs and load checks for scoring, wear, or damage. Replace as necessary.
7. Apply clean hydraulic oil to all internal parts.
8. Install load check (10), spring (9), and O-ring (11) into each spool section.
9. Assemble sections (1—6), making sure load checks (10), springs (9), and O-rings (11) remain in position.

**IMPORTANT: Tighten tie rod and nuts evenly to prevent valve spool binding or leakage between sections.**

10. Evenly tighten tie rod nuts (8) to specifications.

### Hydraulic Control Valve—Specification

Control Valve Assembly	
5/16-18 in. Tie Rod	
Nuts—Torque.....	17—23 N·m 13—17 lb·ft
Control Valve Assembly	
3/8-24 in. Tie Rod	
Nuts—Torque.....	40—49 N·m 30—36 lb·ft

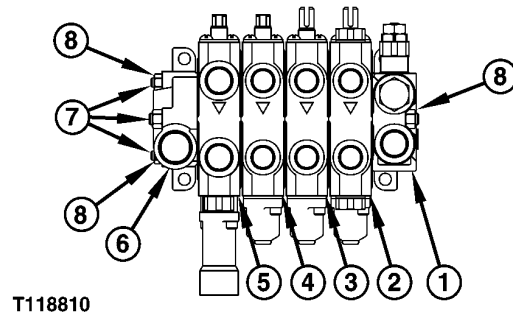

T118810

T118810—UN—10DEC98

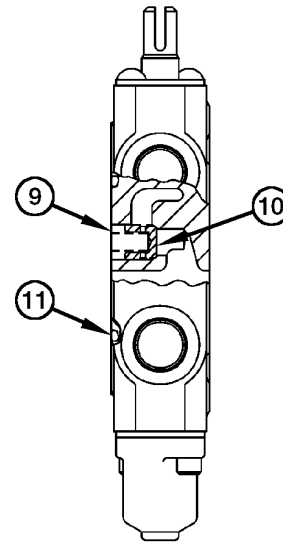

T119779

T119779—UN—22JAN09

- 1— Inlet Section
- 2— Auxiliary Section
- 3— Angle Section
- 4— Tilt Section
- 5— Lift Section
- 6— Outlet Section

- 7— Tie Rod (3 used)
- 8— Nut (6 used)
- 9— Spring (1 in each spool section)
- 10— Load Check (1 in each spool section)
- 11— O-Ring (1 between each section)

CED, TX03768, 2527 -19-29JUL09-1/1

### Wiper Seals and Lip Seals on Hydraulic Control Valve Remove and Install

*NOTE: Replace cap end seals first and tang end seals second. On cap ends, hold tang ends together by placing a screwdriver through tang ends linkage holes.*

1. Remove screws (1) and retainer plate (2) from valve section.
2. Use an O-ring pick to remove wiper seal (3) and lip seal (4).

1— Screw (2 used)  
2— Retainer Plate  
3— Wiper Seal

4— Lip Seal  
5— Spool

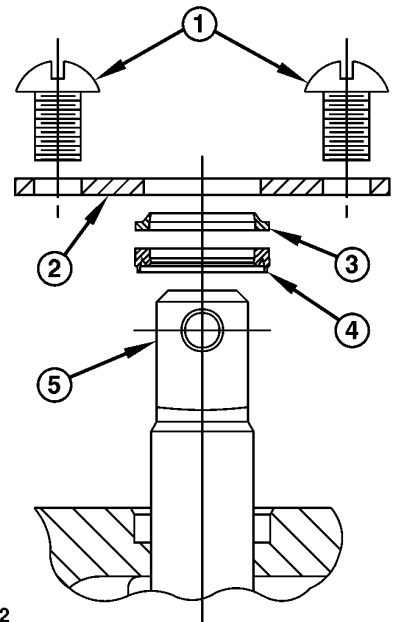

T118812

Wiper and Lip Seal Assembly

T118812 —UN—10DEC98

Continued on next page

CED, TX03768, 2528 -19-10JUL09-1/7

3. Remove socket head cap screws (10) and cap (9) from valve section.
4. Remove spool end screw (8), spring seats (6), centering spring (7) and retainer plate (2).
5. Use an O-ring pick to remove wiper seal (3) and lip seal (4).

- |                         |                                    |
|-------------------------|------------------------------------|
| 2— Retainer Plate       | 7— Centering Spring                |
| 3— Wiper Seal           | 8— Spool End Screw                 |
| 4— Lip Seal             | 9— Cap                             |
| 5— Spool                | 10— Socket Head Cap Screw (2 used) |
| 6— Spring Seat (2 used) |                                    |

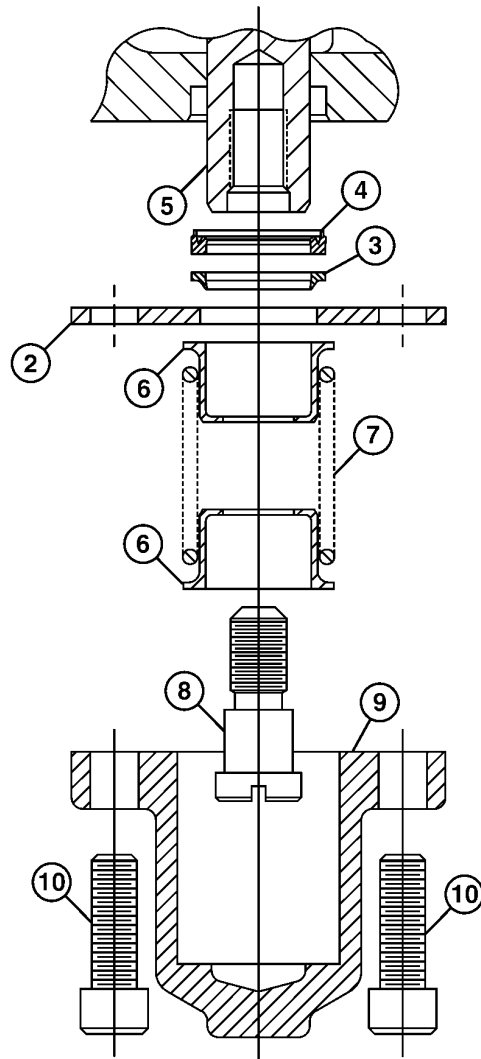

Wiper, Lip Seal and Spool Assembly

TX1060104 — UN—04JUN09

Continued on next page

CED, TX03768, 2528 -19-10JUL09-2/7

**IMPORTANT:** Avoid damage to OD or ID of new lip seal during installation. JDG10583 Seal Installation Tool **MUST** be used to install lip seal and wiper seal.

*NOTE:* Tang (12) of JDG10583 Seal Installation Tool compresses the seal to prevent air from being trapped under it during installation.

6. Lube lip seal (4) and place lip seal into JDG10583 Seal Installation Tool (11) with open side of seal away from tool.
7. Place seal installation tool over end of spool.

4— Lip Seal  
11— JDG10583 Seal Installation Tool

12— Tang

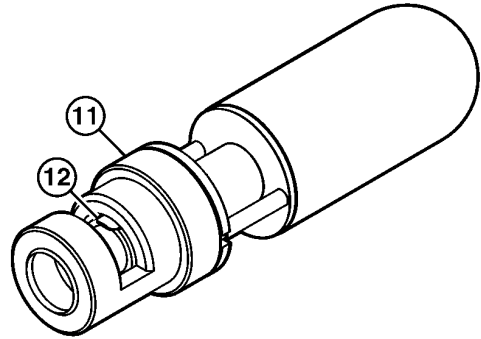

JDG10583 Seal Installation Tool



JDG10583 Seal Installation Tool

TX1060098 —UN—04JUN09

TX1060099A —UN—04JUN09

Continued on next page

CED, TX03768, 2528 -19-10JUL09-3/7

8. Push seal installation tool (11) to install lip seal into counterbore of valve housing.
9. Lube wiper seal and place wiper seal into seal installation tool with smaller OD of wiper seal into tool.
10. Place seal installation tool over end of spool.

11— JDG10583 Seal Installation Tool

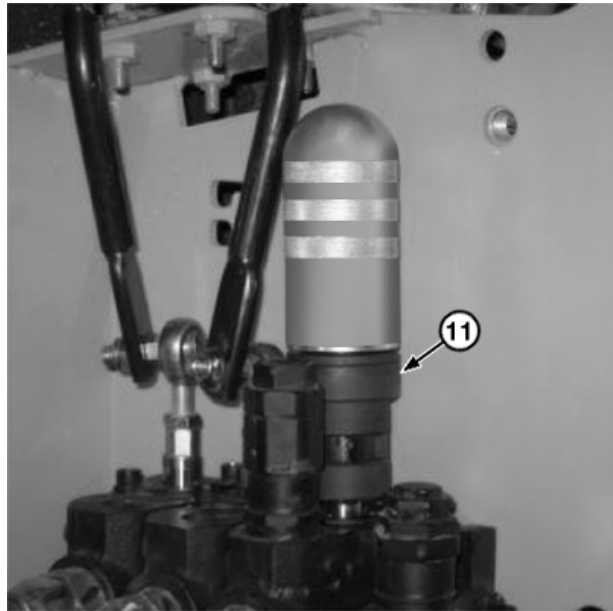

TX1060101A —UN—04JUN09

JDG10583 Seal Installation Tool

CED,TX03768,2528 -19-10JUL09-4/7

**IMPORTANT: Avoid damage to the wiper seal during assembly. The wiper seal must sit flush just below the surface of the valve housing**

11. Push seal installation tool to install wiper seal (3) into counterbore just below surface of valve housing.

3— Wiper Seal  
4— Lip Seal

9— Cap

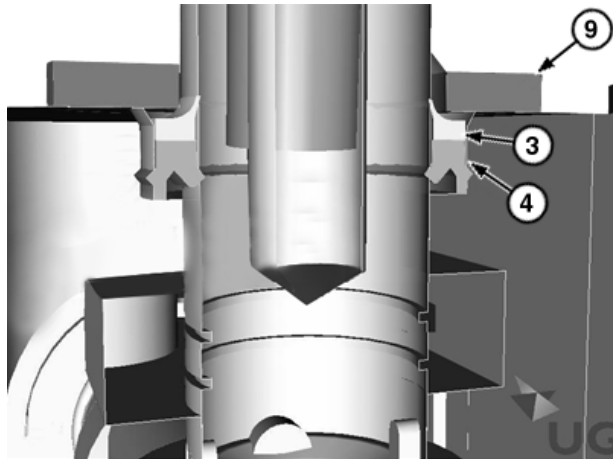

TX1060103A —UN—04JUN09

Seal Installation

Continued on next page

CED,TX03768,2528 -19-10JUL09-5/7

12. Install retainer plate (2), spring seats (6) and centering spring (7).
13. Clean threads of spool (5) and spool end screw (8). Apply PM37509 Cure Primer to threads.
14. Apply PM37421 Thread Lock and Sealer (high strength) to threads of spool end screw (8). Install and tighten spool end screw to specification.

**Hydraulic Control Valve—Specification**

Valve Spool End	
Screw—Torque.....	9.5 N·m 84 lb.-in.

15. Install cap (9) and socket head cap screws (10). Tighten to specification.

**Hydraulic Control Valve—Specification**

Valve Spool Cap Socket	
Head Screws—Torque.....	9.5 N·m 84 lb.-in.

- |                         |                                    |
|-------------------------|------------------------------------|
| 2— Retainer Plate       | 7— Centering Spring                |
| 3— Wiper Seal           | 8— Spool End Screw                 |
| 4— Lip Seal             | 9— Cap                             |
| 5— Spool                | 10— Socket Head Cap Screw (2 used) |
| 6— Spring Seat (2 used) |                                    |

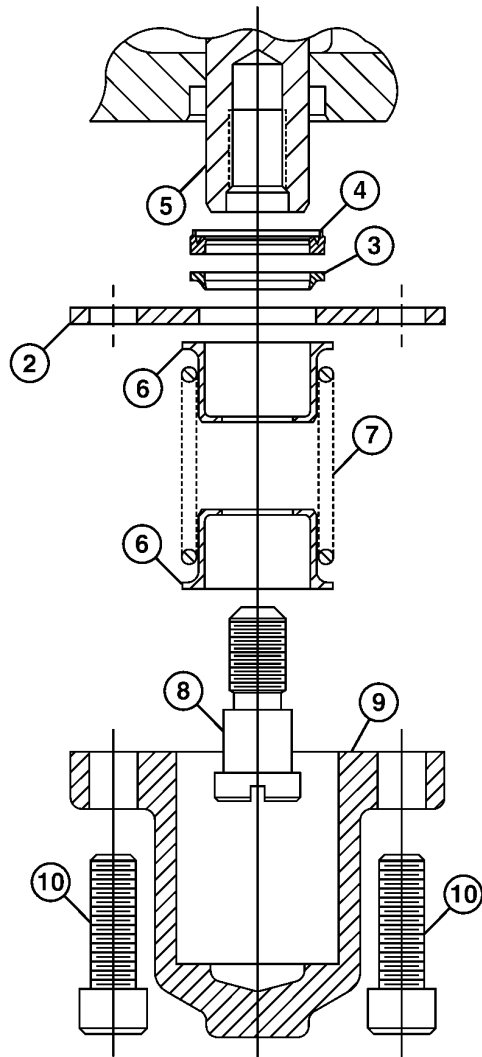

Wiper, Lip Seal and Spool Assembly

Continued on next page

CED, TX03768, 2528 -19-10, JUL09-6/7

TX1060104 —UN—04JUN09

16. Install retainer plate (2) and screws (1). Tighten to specification.

**Hydraulic Control Valve—Specification**

Valve Spool Retainer	
Plate Screws—Torque.....	5.5 N·m 48 lb.-in.

17. Check for correct installation of seals by pushing down on spool (5). Spool must return to neutral position.

- |                  |            |
|------------------|------------|
| 1—Screw (2 used) | 4—Lip Seal |
| 2—Retainer Plate | 5—Spool    |
| 3—Wiper Seal     |            |

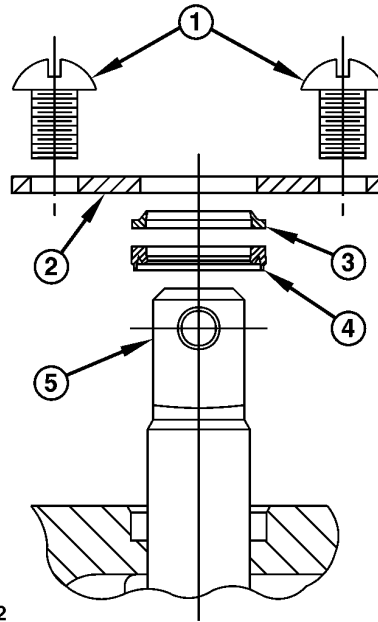

T118812

Wiper and Lip Seal Assembly

T118812 —UN—10DEC98

CED, TX03768, 2528 -19-10JUL09-7/7

**Auxiliary Control Valve Section Disassemble and Assemble**

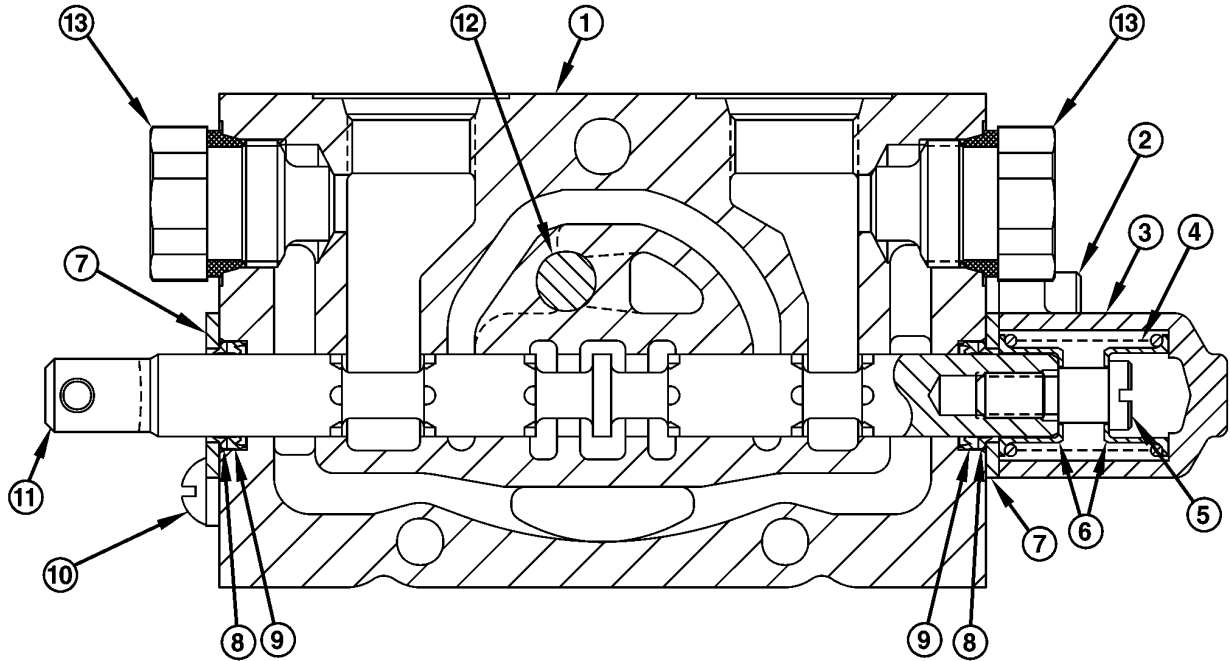

T118814

Control Valve Auxiliary Section

- |                       |                             |                           |                           |
|-----------------------|-----------------------------|---------------------------|---------------------------|
| 1— Valve Housing      | 5— Spool End Screw          | 9— Lip Seal (2 used)      | 13— Shutoff Plug (2 used) |
| 2— Cap Screw (2 used) | 6— Spring Seat (2 used)     | 10— Screw (2 used)        |                           |
| 3— Cap                | 7— Retaining Plate (2 used) | 11— Spool                 |                           |
| 4— Centering Spring   | 8— Wiper Seal (2 used)      | 12— Load Check and Spring |                           |

**IMPORTANT: Spool must be installed into the valve housing the same way it was removed for proper operation of the hydraulic function.**

- Remove parts (2, 3, 7, 10 and 11) from valve housing (1).
- Using a protective cover or wooden blocks, put spool in vise. Remove spool end screw (5), centering spring (4) and spring seats (6).
- Inspect parts for wear or damage. Replace all O-rings and seals.
- Put clean hydraulic oil on spool and install spool into valve housing. Install lip seals (9) and wiper seals (8) using JDG10583 Seal Installation Tool. See Wiper Seals and Lip Seals on Hydraulic Control Valve Remove and Install. (Group 3260.)
- Install parts (4—7) on spool. Clean threads of spool and spool end screw. Apply PM37509 Cure Primer to threads. Apply PM37421 Thread Lock and Sealer

(high strength) on spool end screw. Install and tighten screw to specification.

**Hydraulic Control Valve—Specification**

Auxiliary Valve Spool End Screw—Torque.....	9.5 N·m
	84 lb.-in.

- Apply grease on centering spring (4).
- Assemble remaining parts. Tighten cap screws (2), screws (10) and shutoff plugs (13) to specifications.

**Hydraulic Control Valve—Specification**

Auxiliary Valve Spool	
Cap Socket Head	
Screws—Torque.....	9.5 N·m
	84 lb.-in.
Auxiliary Valve Retainer	
Plate Screws—Torque.....	5.5 N·m
	48 lb.-in.
Auxiliary Valve Shutoff	
Plugs—Torque.....	45 N·m
	33 lb.-ft.

CED.OUTX547,200 -19-29JUL09-1/1

T118814 —UN—14DEC98

## Angle Control Valve Section Disassemble and Assemble

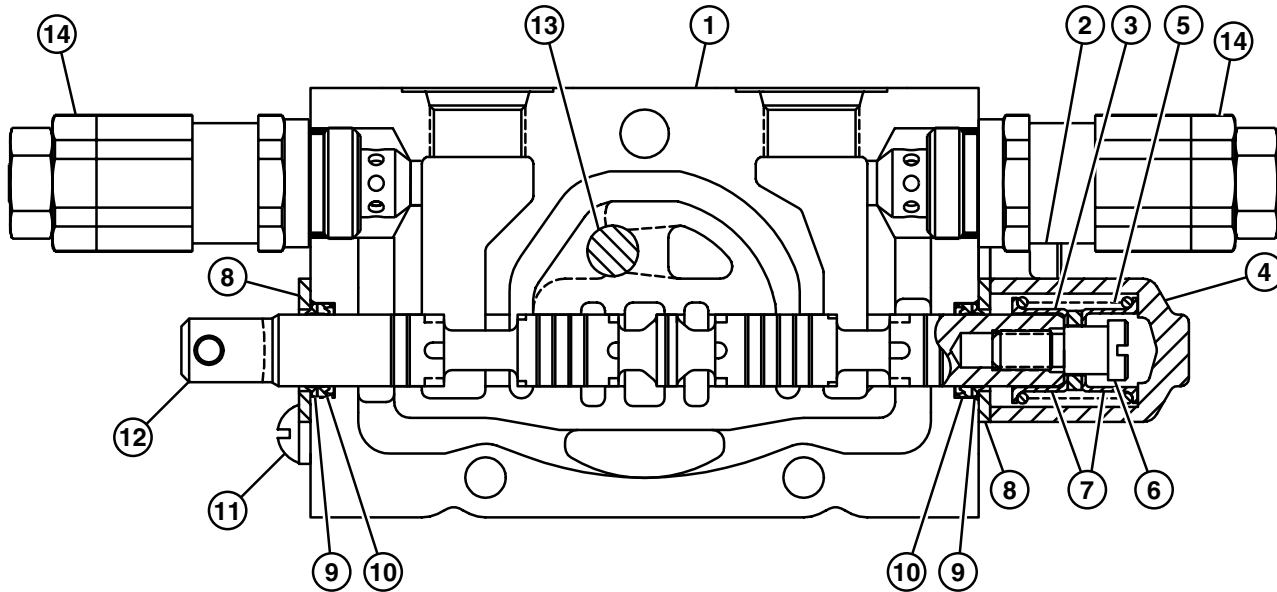

TX1060176—UN—08JUN09

TX1060176

Control Valve Angle Section

- |                       |                             |                        |                                     |
|-----------------------|-----------------------------|------------------------|-------------------------------------|
| 1— Valve Housing      | 5— Centering Spring         | 9— Wiper Seal (2 used) | 13— Load Check and Spring           |
| 2— Cap Screw (2 used) | 6— Spool End Screw          | 10— Lip Seal (2 used)  | 14— Work Port Relief Valve (2 used) |
| 3— Spacer             | 7— Spring Seat (2 used)     | 11— Screw (2 used)     |                                     |
| 4— Cap                | 8— Retaining Plate (2 used) | 12— Spool              |                                     |

**IMPORTANT: Spool must be installed into the valve housing the same way it was removed for proper operation of the hydraulic function.**

1. Remove parts (2, 4, 8, and 11) and spool (12) from valve housing (1).

**IMPORTANT: To avoid changing adjustment, do not loosen adjustment screw on end of relief.**

2. Remove work port relief valves (14).
3. Using a protective cover or wooden blocks, place spool in vise. Remove spool end screw (6), spacer (3), centering spring (5) and spring seats (7).
4. Inspect parts for wear or damage. Replace all O-rings and seals.
5. Put clean hydraulic oil on spool and install spool into valve housing (1). Install lip seals (10) and wiper seals (9) using JDG10583 Seal Installation Tool. See Wiper Seals and Lip Seals on Hydraulic Control Valve Remove and Install. (Group 3260.)
6. Install parts (3 and 5—8) on spool. Clean threads of spool and spool end screw. Apply PM37509 Cure

Primer to threads. Apply PM37421 Thread Lock and Sealer (high strength) on spool end screw. Install and tighten spool end screw to specification.

**Hydraulic Control Valve—Specification**

Angle Valve Spool End	
Screw—Torque.....	9.5 N·m 84 lb.-in.

7. Apply grease to centering spring (5).
8. Assemble remaining parts. Tighten cap screws (2) and screws (11) to specifications.

**Hydraulic Control Valve—Specification**

Angle Valve Spool	
Cap Socket Head	
Screws—Torque.....	9.5 N·m 84 lb.-in.
Angle Valve Retainer	
Plate Screws—Torque.....	5.5 N·m 48 lb.-in.

**IMPORTANT: Tightening work ports relief using jam nut on end of relief will cause damage to work ports relief. Do not tighten work ports relief using jam nut on end of relief.**

Continued on next page

CED,OUO1004,533-19-14JUL09-1/2

*Hydraulic System*

9. Assemble work ports reliefs (14) into housing (1).  
Tighten reliefs to specification.

**Hydraulic Control Valve—Specification**

Angle Valve Circuit

Relief—Torque..... 41—49 N·m  
30—36 lb.-ft.

CED, OYO1004,533 -19-14JUL09-2/2

### Tilt Control Valve Section Disassemble and Assemble

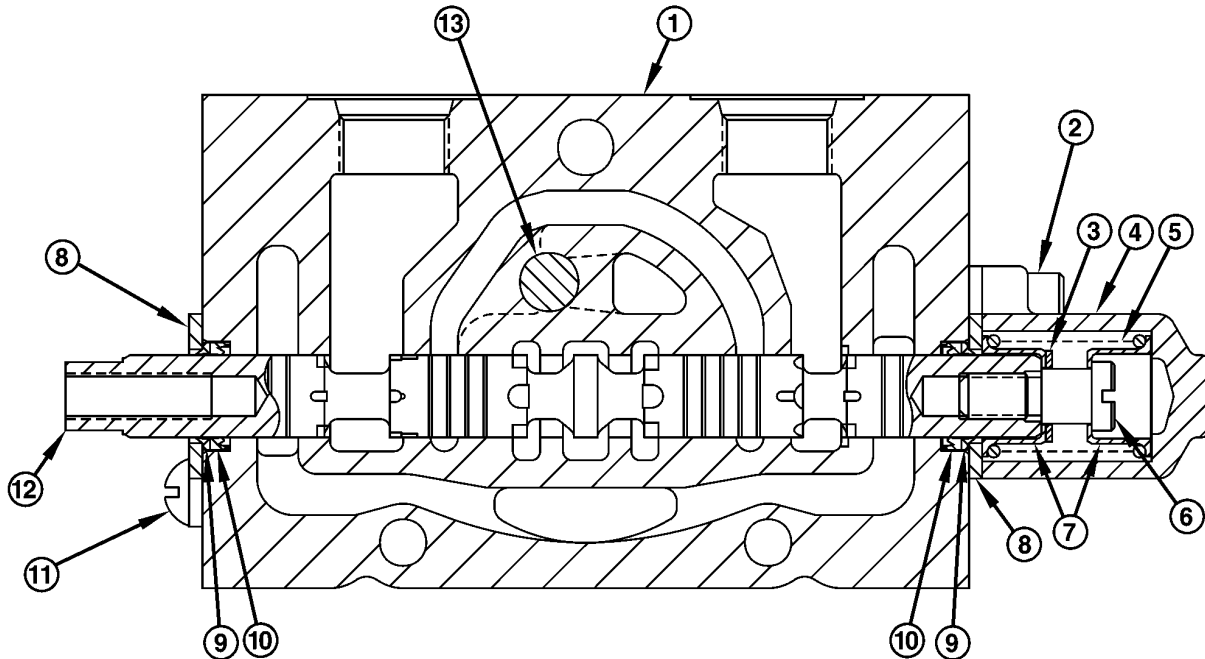

Control Valve Tilt Section

- |                       |                             |                        |                           |
|-----------------------|-----------------------------|------------------------|---------------------------|
| 1— Valve Housing      | 5— Centering Spring         | 9— Wiper Seal (2 used) | 13— Load Check and Spring |
| 2— Cap Screw (2 used) | 6— Spool End Screw          | 10— Lip Seal (2 used)  |                           |
| 3— Spacer             | 7— Spring Seat (2 used)     | 11— Screw (2 used)     |                           |
| 4— Cap                | 8— Retaining Plate (2 used) | 12— Spool              |                           |

**IMPORTANT: Spool must be installed into the valve housing the same way it was removed for proper operation of the hydraulic function.**

- Remove parts (2, 4, 8, 11 and 12) from valve housing (1).
- Using a protective cover or wooden blocks, place spool in vise. Remove spool end screw (6), spacer (3), centering spring (5) and spring seats (7).
- Inspect parts for wear or damage. Replace all O-rings and seals.
- Put clean hydraulic oil on spool and install spool into valve housing. Install lip seals (10) and wiper seals (9) using JDG10583 Seal Installation Tool. See Wiper Seals and Lip Seals on Hydraulic Control Valve Remove and Install. (Group 3260.)
- Install parts (3 and 5—8) on spool. Clean threads of spool and spool end screw. Apply PM37509 Cure Primer to threads. Apply PM37421 Thread Lock and

Sealer (high strength) on spool end screw (6). Install and tighten tilt valve spool end screw to specification.

#### Hydraulic Control Valve—Specification

Tilt Valve Spool End	
Screw—Torque.....	9.5 N·m 84 lb.-in.

- Apply grease to centering spring (5).
- Assemble remaining parts. Tighten cap screws (2) and screws (11) to specifications.

#### Hydraulic Control Valve—Specification

Tilt Valve Spool	
Cap Socket Head	
Screws—Torque.....	9.5 N·m 84 lb.-in.
Tilt Valve Retainer Plate	
Screws—Torque.....	5.5 N·m 48 lb.-in.

CED,OUO1004,534 -19-29JUL09-1/1

T118816—UN—14DEC98

### Lift Control Valve Section Disassemble and Assemble

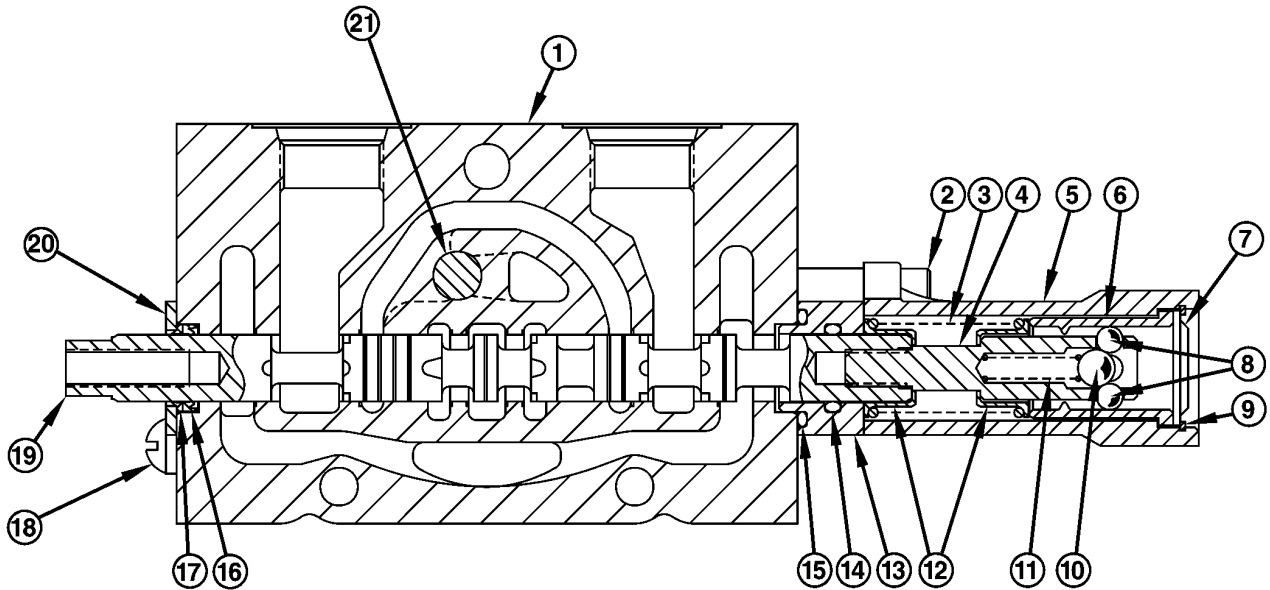

T118817

Control Valve Lift Section

1— Valve Housing	7— Spacer	13— Cap Spacer	19— Spool
2— Cap Screw (2 used)	8— Small Detent Ball (4 used)	14— O-Ring	20— Retainer Plate
3— Centering Spring	9— Retainer Ring	15— O-Ring	21— Check Valve and Spring
4— Detent Spool End Screw	10— Large Detent Ball	16— Lip Seal	
5— Cap	11— Detent Spring	17— Wiper Seal	
6— Detent Sleeve	12— Spring Seat (2 used)	18— Screw (2 used)	

**IMPORTANT:** For proper valve disassembly, spool should be in center (neutral) position, not the detent position. Spool must be installed into the valve housing the same way it was removed for proper operation of the hydraulic function.

1. Remove retainer ring (9) with a screwdriver and spacer (7). Remove parts (2, 18, and 20). The spool (19) and whole end assembly (3—6, 8 and 10—15) can now be removed from the valve housing (1).

**NOTE:** Use a catch pan under valve spool assembly for catching four small detent balls (8) during procedure.

2. Using a protective cover or wooden blocks, put spool in vise. Slide detent spool cap (5) and detent sleeve (6) off of detent spool end screw (4) until detent sleeve is stopped by detent balls (8). Push a 3.8 mm (0.125 in.) punch through detent sleeve into detent spool end screw (4) and depress large detent ball (10) against detent spring (11). This will retract the four small detent balls (8) to allow full removal of parts (5 and 6). Remove detent sleeve from cap (5).

3. Remove parts (3, 4, 8 and 10—12). Remove detent balls (8 and 10) and detent spring (11) from detent spool end screw (4). Remove parts (13—15) from spool (19) and seals (16 and 17) from valve housing (1).

4. Inspect parts for wear or damage. Replace all O-rings and seals.

5. Put clean hydraulic oil on spool (19) and install spool into valve housing (1). On the spool tang (handle) end, install lip seal (16) and wiper seal (17) using JDG10583 Seal Installation Tool. See Wiper Seals and Lip Seals on Hydraulic Control Valve Remove and Install. (Group 3260.)

**NOTE:** Lubricate O-ring (14) prior to installation to prevent O-ring damage.

6. On cap end, install cap spacer (13) and O-rings (14 and 15).

Continued on next page

CED.TX03768,2533 -19-14,JUL09-1/2

T118817 —UN—14DEC98

Hydraulic System

- 7. Clean threads of spool and spool end screw. Apply PM37509 Cure Primer to threads. Apply PM37421 Thread Lock and Sealer (high strength) on threads and assemble spring seats (12), centering spring (3) and detent spool end screw end screw (4) onto end of spool. Tighten spool end screw to specification.

**Hydraulic Control Valve—Specification**

Lift Valve Spool End	
Screw—Torque.....	9.5 N·m 84 lb.-in.

- 8. Apply grease to centering spring (3).
- 9. Install detent spring (11) and detent balls (8 and 10) into detent spool end screw (4). Hold small detent balls (8) in place with grease.
- 10. Slide cap (5) onto spool end. Slide detent sleeve (6) into cap (5), until it touches detent balls (8). Push a 3.18 mm (0.125 in.) punch through detent sleeve (6) into detent spool end screw (4) and depress large detent ball (10) against detent spring (11). This will

retract the four detent balls (8) to allow full installation of the detent sleeve (6) over the spool end and inside the cap.

Check to make sure that all four detent balls (8) are in place.

- 11. Install spacer (7) and retainer ring (9). Install cap screws (2) and tighten to specification.

**Hydraulic Control Valve—Specification**

Lift Valve Cap	
Socket Head Cap	
Screws—Torque.....	9.5 N·m 84 lb.-in.

- 12. Install retainer plate (20) and tighten screws (18) to specification.

**Hydraulic Control Valve—Specification**

Lift Valve Spool Retaining	
Plate Screws—Torque.....	5.5 N·m 48 lb.-in.

CED,TX03768,2533 -19-14JUL09-2/2

### Integrated Grade Control (IGC) Lever Remove and Install (S.N. 130886—)

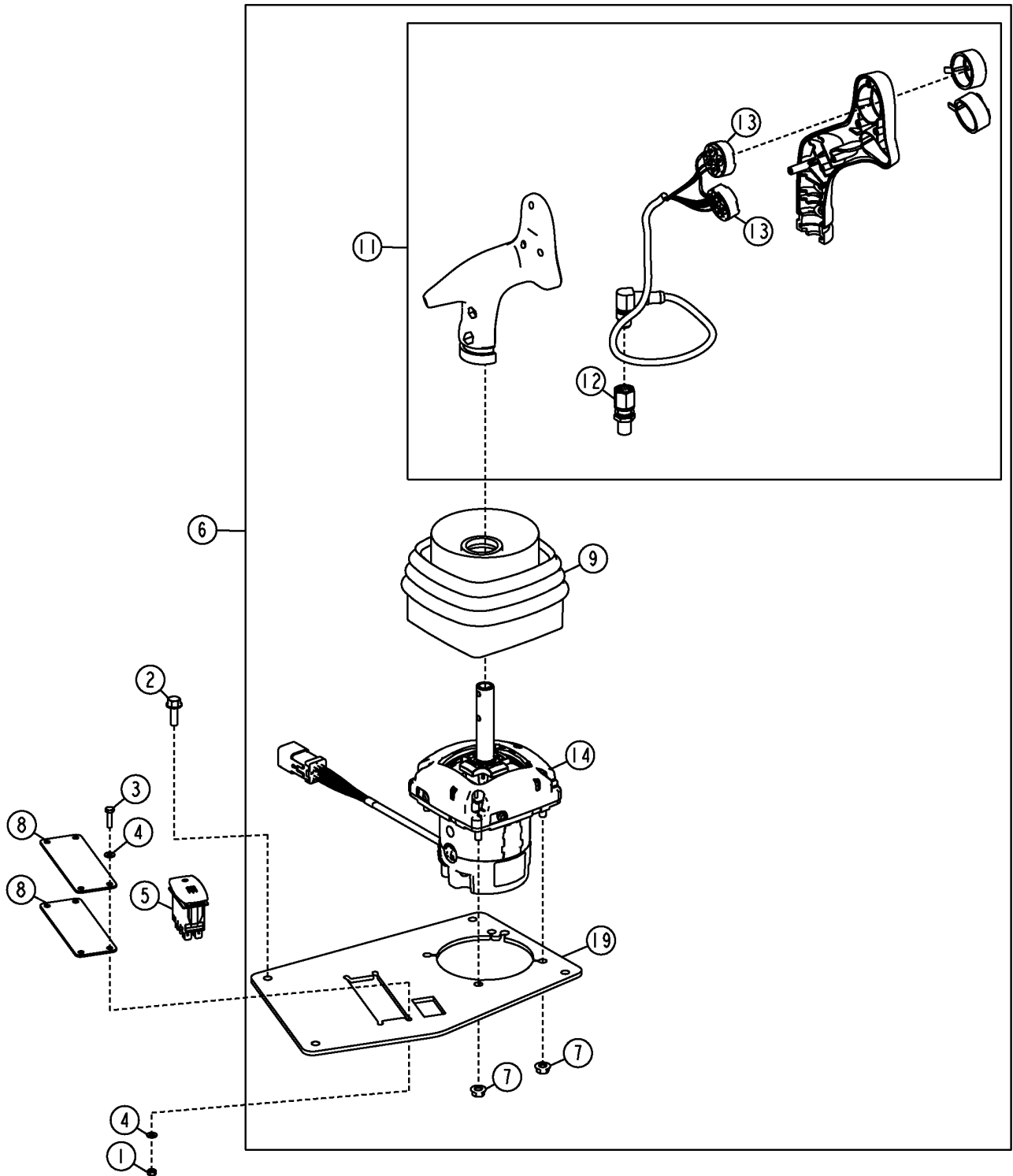

TX1017140

Integrated Grade Control (IGC) Lever Assembly (Joystick) (S.N. 130886-)

Continued on next page

KV70328.00001E7 -19-24MAY07-1/4

TX1017140—UN—28DEC06

## Hydraulic System

1— Nut (4 Used)	6— IGC Lever (Joystick) (Complete)	11— Handle Assembly	16— Not Used
2— Cap Screw (4 Used)	7— Nut (4 Used)	12— Electrical Connector	17— Not Used
3— Cap Screw (4 Used)	8— Plate	13— Cover	18— Not Used
4— Washer (8 Used)	9— Boot	14— Multi-function Controller	19— Plate
5— STC Adapter Fitting	10— Not Used	15— Not Used	

1. Turn battery disconnect switch to OFF position.

KV70328,00001E7 -19-24MAY07-2/4

2. Remove four cap screws (2).
3. Lift plate (19) to expose electrical connections.

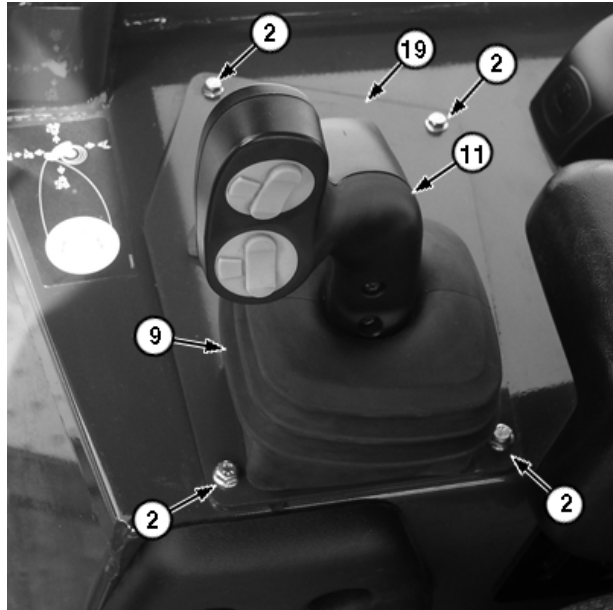

TX1023038A —UN—22MAY07

Integrated Grade Control (IGC) Lever (S.N. 130886-)

KV70328,00001E7 -19-24MAY07-3/4

4. Disconnect electrical connections (12, 20, 21) from assembly.
5. Remove complete lever assembly from machine.
6. Remove four nuts (7) from bottom of IGC lever (6) and remove IGC lever from plate.
7. Repair or replace parts as required
8. Install IGC lever (6) in plate (19) using four nuts (7)
9. Connect electrical connections (12, 20, 21)
10. Install IGC lever assembly using four cap screws (2).
11. Turn battery disconnect switch to ON position.
12. Operate machine and verify all functions work correctly.

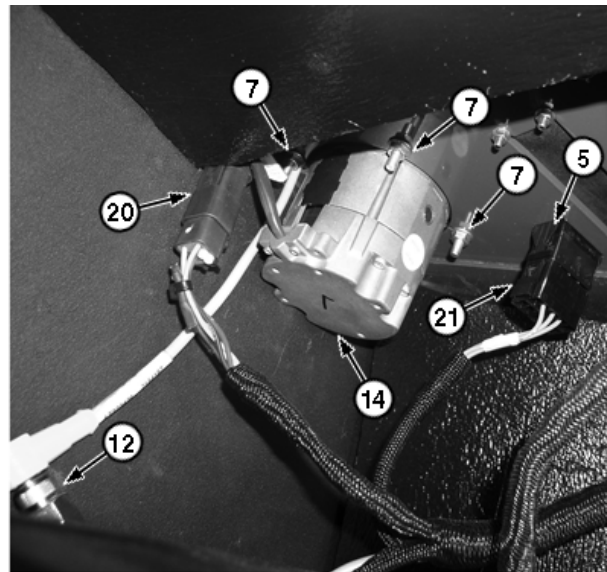

TX1023043A —UN—22MAY07

Integrated Grade Control (IGC) Lever (S.N. 130886-)  
(from inside right side panel)

KV70328,00001E7 -19-24MAY07-4/4

### Integrated Grade Control (IGC) Lever Disassemble and Assemble (S.N. 130886—)

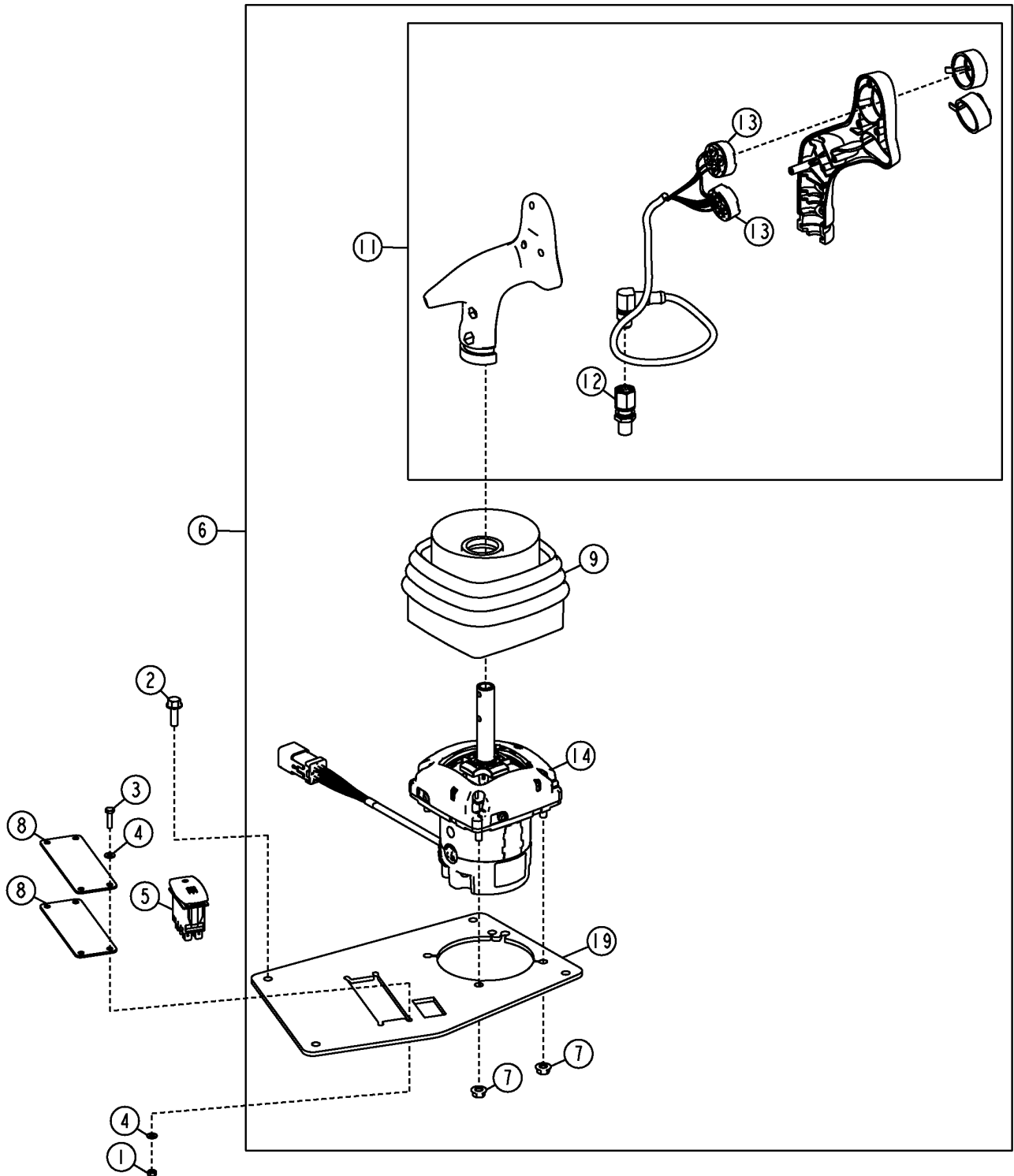

TX1017140

Integrated Grade Control (IGC) Lever Assembly (Joystick) (S.N. 130886-)

Continued on next page

KV70328.00001E8 -19-24MAY07-1/2

TX1017140—UN—28DEC06

## Hydraulic System

1— Nut (4 Used)	6— IGC Lever (Joystick) (Complete)	11— Handle Assembly	16— Not Used
2— Cap Screw (4 Used)	7— Nut (4 Used)	12— Electrical Connector	17— Not Used
3— Cap Screw (4 Used)	8— Plate	13— Cover	18— Not Used
4— Washer (8 Used)	9— Boot	14— Multi-function Controller	19— Plate
5— STC Adapter Fitting	10— Not Used	15— Not Used	

Disassemble and assemble parts as shown.

KV70328,00001E8 -19-24MAY07-2/2

### System and Angle Circuit Relief Valve Disassemble and Assemble

*NOTE: Only O-rings and backup rings are serviceable as a kit. If other parts are damaged, replace relief valve assembly.*

1. Disassemble and inspect parts for wear and damage.
2. Put clean hydraulic oil on all parts before assembly.
3. Adjust system relief valve. See Hydraulic System Relief Valve Test. (Group 9025-25.)

A—Adjusting Screw	J—Piston
B—O-Ring (2 used)	K—Poppet
C—O-Ring	L—O-Ring
D—Pilot Poppet	M—O-Ring
E—Spring	N—O-Ring
F—Backup Ring	O—Valve Body
G—Spring	P—Spring
H—Backup Ring	Q—Valve Body Plug
I—Poppet	R—Nut

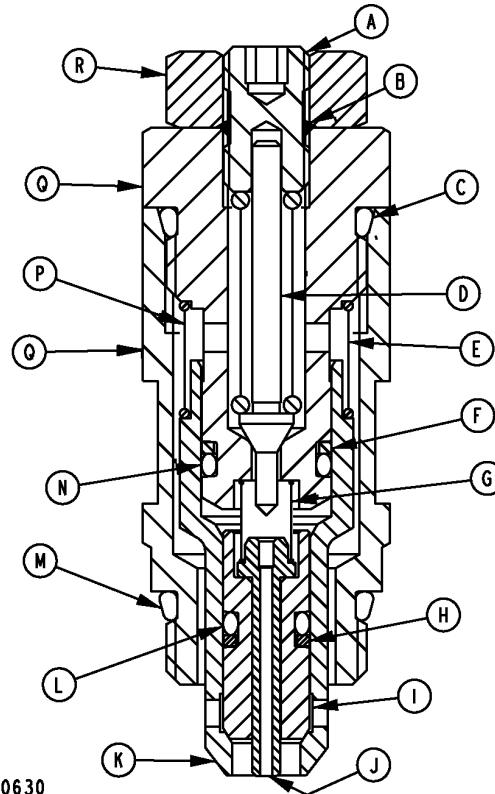

T100630

T100630—UN—05MAR97

CED.OUTX547,201 -19-07DEC01-1/1

### Tilt Cylinder Remove and Install

1. Lower all equipment to the ground.
2. Stop engine. Operate all hydraulic controls to release pressure in hydraulic system.

**⚠ CAUTION:** To avoid injury from escaping fluid under pressure, stop engine and relieve the pressure in the system before disconnecting or connecting hydraulic lines. Tighten all connections before applying pressure.

3. Tag and mark cylinder hoses (3 and 4).
4. Disconnect cylinder hoses (3 and 4). Cap and plug all openings.
5. Attach cylinder to hoist using lift strap.
6. Remove cap screw, retainer, and pin (2). Remove cap screws and retainers on tilt cylinder head end and angle cylinder rod end. Drive tilt cylinder pin (1) and angle pin out.
7. Remove cylinder.
8. Inspect rubber bushings, replace if necessary. See Angle, Lift, and Tilt Cylinders Disassemble and Assemble (John Deere 120 Series Cylinders). (Group 3260.)
9. Install cylinder and pins. Connect hoses.

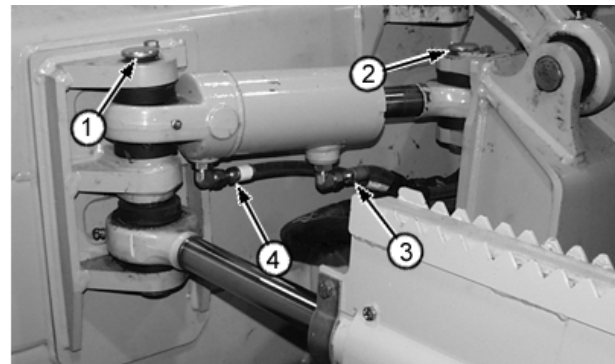
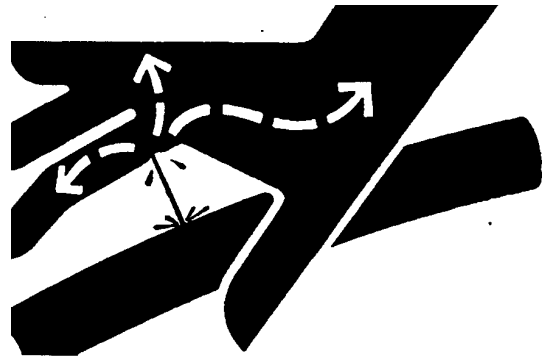

1— Pin Head End  
2— Pin Rod End

3— Cylinder Rod End Hose  
4— Cylinder Head End Hose

X8811 —UN—23AUG88

T119484B —UN—11JAN89

CED, TX03768, 2529 -19-05FEB09-1/1

### Angle Cylinder Remove and Install

1. Lower all equipment to the ground.
2. Stop engine. Operate all hydraulic controls to relieve system pressure.

**CAUTION:** To avoid injury from escaping fluid under pressure, stop engine and relieve the pressure in the system before disconnecting or connecting hydraulic or other lines. Tighten all connections before applying pressure.

3. Tag and disconnect cylinder hoses (1 and 2) and grease lines. Cap and plug all openings.
4. Attach cylinder to hoist using lift strap.
5. Remove cap screw, retainer, and pin (3). Remove cap screws and retainers on tilt cylinder head end and angle cylinder rod end. Drive tilt cylinder head end pin (4) and angle rod end pin (5) out.
6. Remove angle cylinder.
7. Inspect rubber bushings. Replace if necessary. See Angle, Lift, and Tilt Cylinders Disassemble and Assemble (John Deere 120 Series Cylinders). (Group 3260.)
8. Install cylinder and pins. Connect hoses and grease lines.

- |                                 |                               |
|---------------------------------|-------------------------------|
| 1— Angle Cylinder Head End Hose | 4— Tilt Cylinder Head End Pin |
| 2— Angle Cylinder Rod End Hose  | 5— Angle Rod End Pin          |
| 3— Angle Cylinder Head End Pin  |                               |

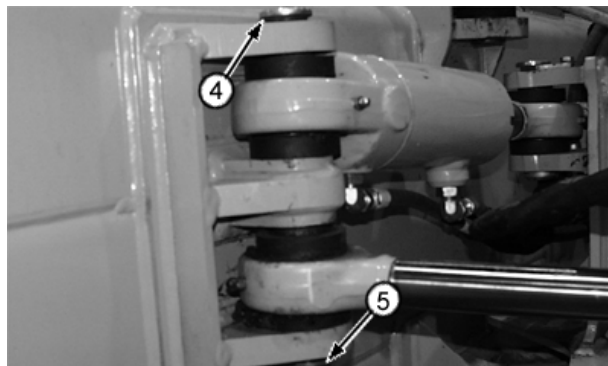
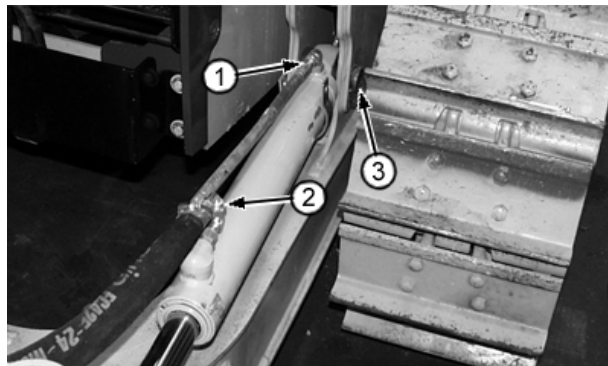
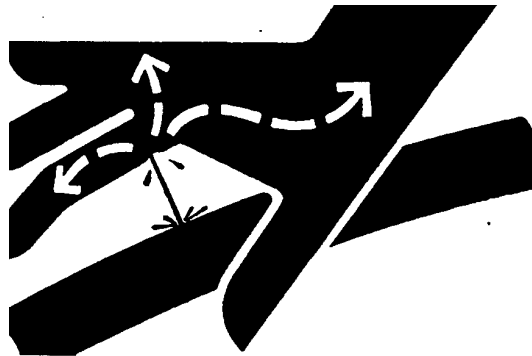

X9811 —UN—23AUG88

T119486B —UN—11JAN89

T119487B —UN—11JAN89

CEDEX03768.2530 -19-05FEB09-1/1

### Lift Cylinder Remove and Install

1. Lower all equipment to the ground.
2. Stop engine. Operate all hydraulic controls to relieve system pressure.

**⚠ CAUTION:** To avoid injury from escaping fluid under pressure, stop engine and relieve the pressure in the system before disconnecting or connecting hydraulic or other lines. Tighten all connections before applying pressure.

3. Tag and disconnect cylinder rod end hose (1) and cylinder head end line (2). Cap and plug all openings.
4. Attach cylinder to hoist using lift strap.
5. Remove cap screws and retainers. Remove pins (3 and 4).
6. Remove lift cylinder. See Angle, Lift, and Tilt Cylinders Disassemble and Assemble (John Deere 120 Series Cylinders). (Group 3260.)
7. Install cylinder and pins. Connect cylinder rod end hose (1) and cylinder head end line (2).

- |                           |                 |
|---------------------------|-----------------|
| 1— Cylinder Rod End Hose  | 3— Head End Pin |
| 2— Cylinder Head End Line | 4— Rod End Pin  |

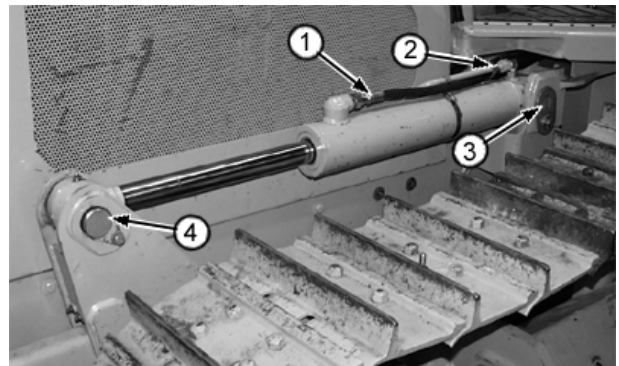
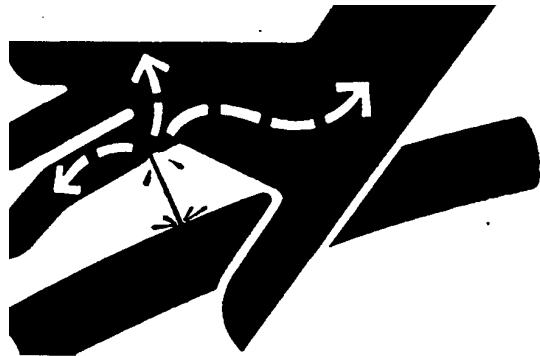

X8811 —UN—23AUG88

T119485B —UN—11JAN99

CED,OUTX547,207 -19-05FEB09-1/1

### Angle, Lift, and Tilt Cylinders Disassemble and Assemble (John Deere 120 Series Cylinders)

See Disassemble Cylinder. TM-H120A. (Group 01) See Assemble Cylinder . TM-H120A. (Group 01)

RG80575,0000007 -19-23JUN08-1/1

*Hydraulic System*

## Section 9900 Dealer Fabricated Tools

### Contents

	Page
<b>Group 0999—Dealer Fabricated Tools</b>	
DF1041 Track Nut Removal Tool .....	9900-0999-1
DF1063 Final Drive Lift Bracket.....	9900-0999-2
DFT1087 Track Recoil Spring Disassembly and Assembly Guard Tool .....	9900-0999-3
DFT1119 Pump Support .....	9900-0999-4
DFT1130 Adapter .....	9900-0999-5
DFT1132 Hydrostatic Motor Removal and Installation Tool.....	9900-0999-6
DFT1137 Hydrostatic Motor Removal and Installation Tool.....	9900-0999-7
DFT1165 Left Hand Hydrostatic Motor Lifting Bracket.....	9900-0999-8
DFT1166 Final Drive Lifting Bracket Adapter .....	9900-0999-9
DFT1167 Final Drive Lifting Bracket Adapter Spacer.....	9900-0999-10
DFT1168 Right Hand Hydrostatic Motor Lifting Bracket.....	9900-0999-11
DFT1211 Final Drive Lifting Bracket Adapter .....	9900-0999-12
DFRW20 Compressor Holding Fixture.....	9900-0999-13
ST4920 Track Recoil Spring Disassembly and Assembly Tool .....	9900-0999-14

*Contents*

DF1041 Track Nut Removal Tool

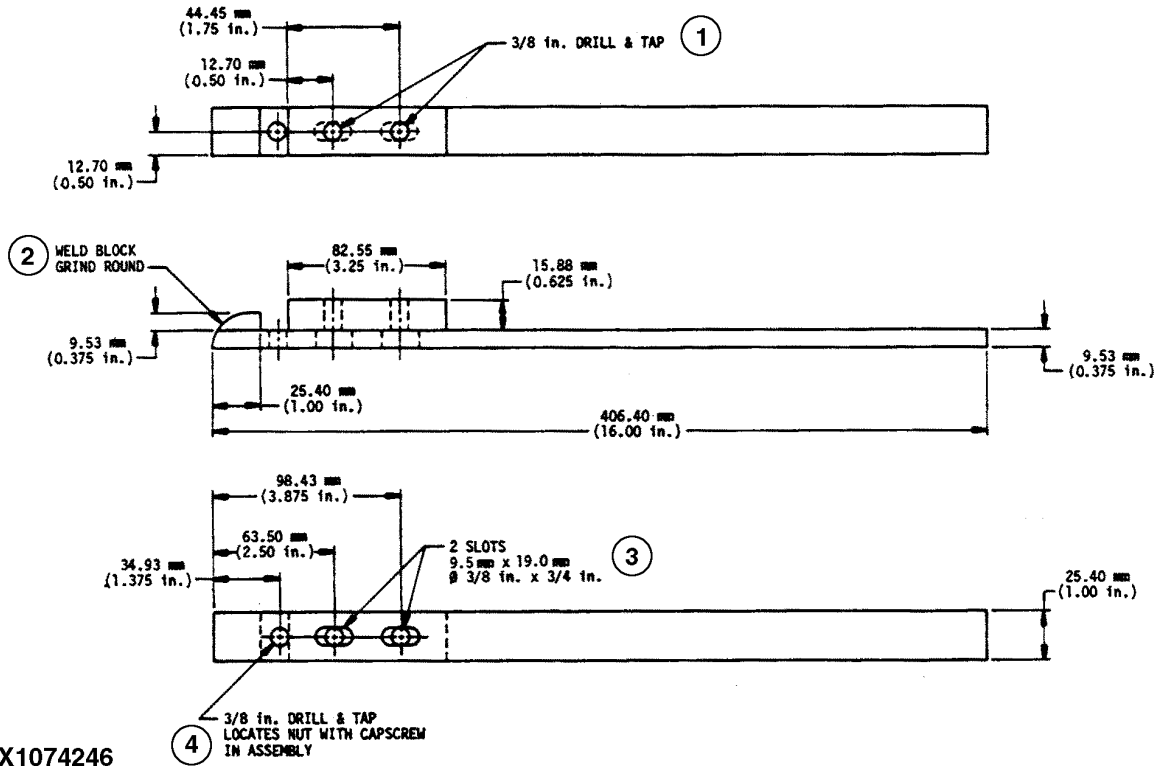

TX1074246

DF1041 Track Nut Removal Tool

1— 3/8 in. Drill and Tap

2— Weld Block; Grind Round

3— 2 Slots 9.5 mm x 19.0 mm (3/8 in. x 3.4 in.)

4— 3/8 in. Drill and Tap; Locates Nut with Cap Screw in Assembly

Tool can be made in dealer's shop. Used to remove and install track shoe nuts.

Material: 1020 Flat Stock

9900,WW11 -19-22MAR10-1/1

TX1074246—UN—22APR10

### DF1063 Final Drive Lift Bracket

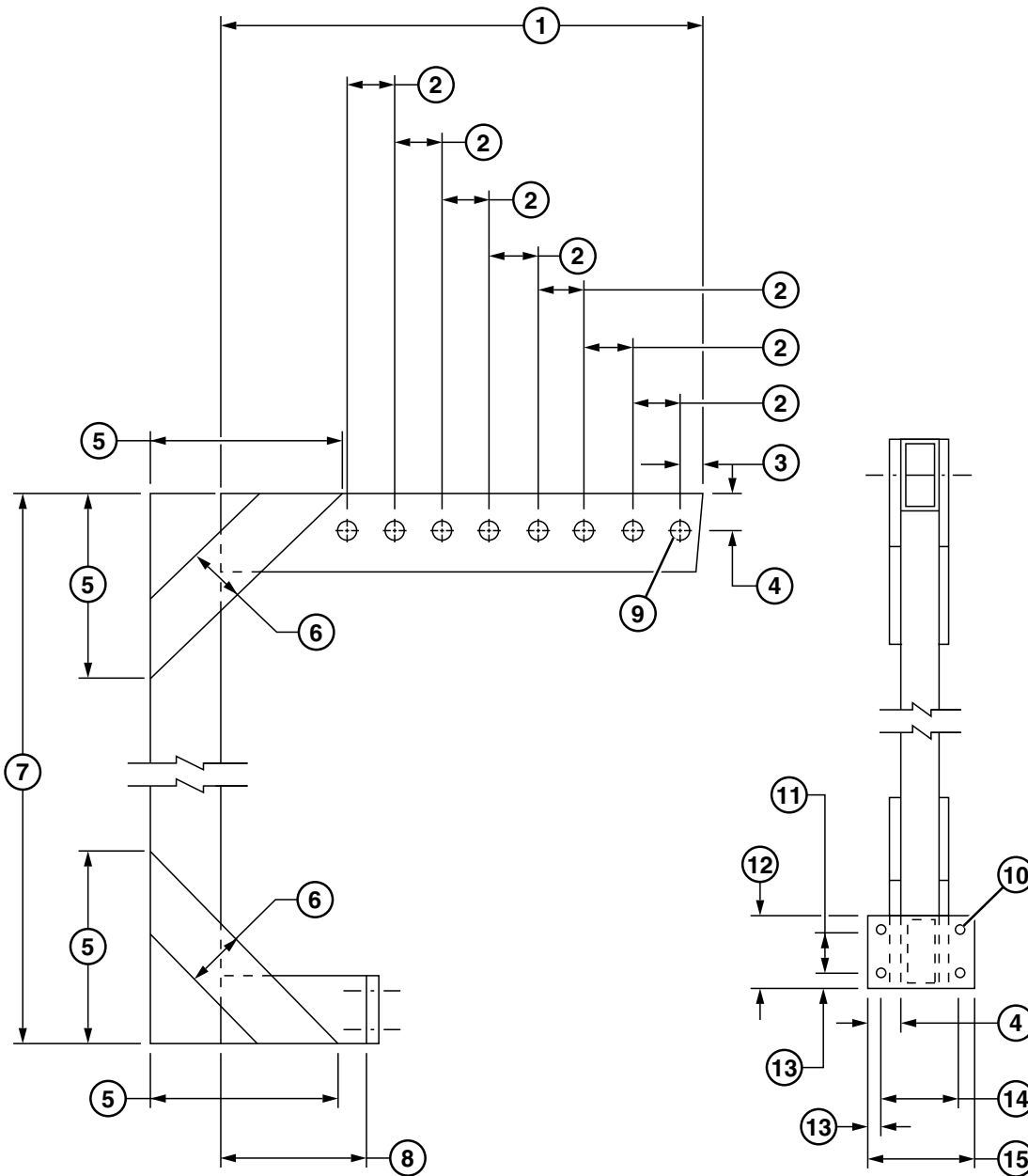

**TX1072724**

*DF1063 Final Drive Lift Bracket*

- |                       |                        |   |                         |
|-----------------------|------------------------|---|-------------------------|
| 1— 508 mm (20.0 in.)  | 5— 203.2 mm (8.00 in.) | 9— 3/4 in. Drill Through Both Sides (8 holes) | 13— 15.9 mm (0.625 in.) |
| 2— 50.8 mm (2.00 in.) | 6— 63.5 mm (2.50 in.)  | 10— 3/8 in. Drill Through (4 holes)           | 14— 82.6 mm (3.25 in.)  |
| 3— 25.4 mm (1.00 in.) | 7— 2286 mm (90.00 in.) | 11— 44.5 mm (1.75 in.)                        | 15— 114.3 mm (4.50 in.) |
| 4— 38.1 mm (1.50 in.) | 8— 152.4 mm (6.00 in.) | 12— 76.2 mm (3.00 in.)                        |                         |

Tool used to remove and install final drives.

Material required:

- 1.5 in. x 3.0 in. Square Tube
- 1/2 in. 1020 Steel
- 3/8 in. x 1.5 in. Cap Screw with Nut (4 used)

CED, TX03399, 5076 -19-24NOV98-1/1

TX1072724—UN—05MAR10

### DFT1087 Track Recoil Spring Disassembly and Assembly Guard Tool

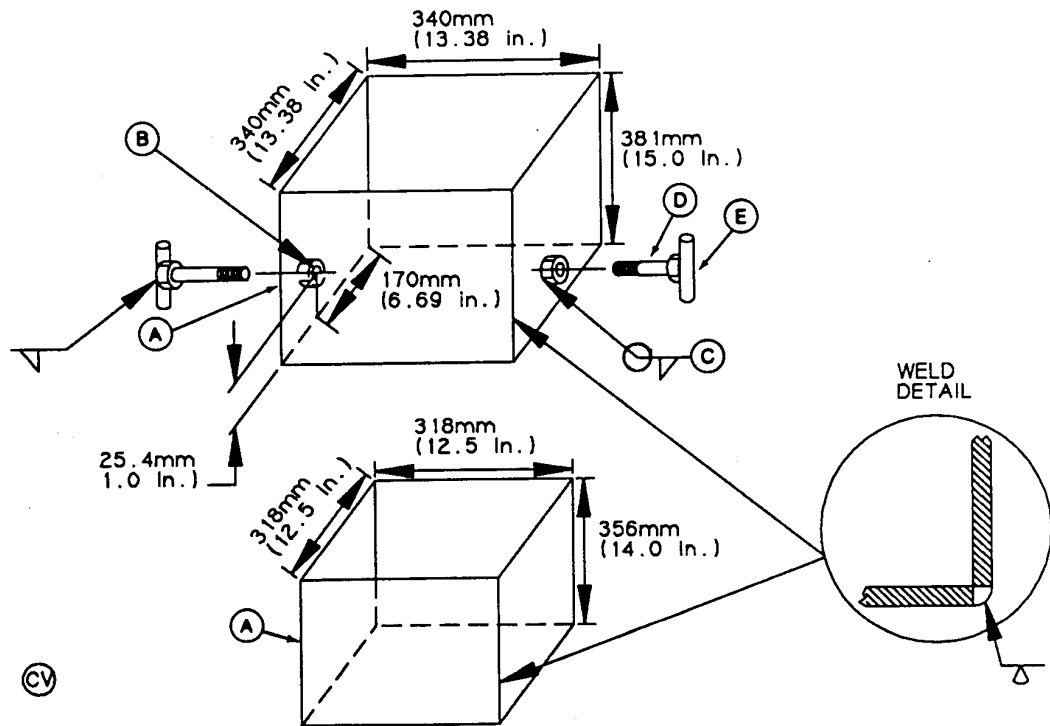

T7162AF (CV)

- |                                |                                  |  |
|--------------------------------|----------------------------------|--|
| A—3/16 in. 1020 CR Steel Plate | C—1/2 in. Nut (2 used)           | E—1/2 x 3 in. Steel Round Stock (2 used) |
| B—9/16 in. Hole (2 places)     | D—1/2 x 2 in. Cap Screw (2 used) |  |

Track Disassembly and Assembly Guard Tool is used with ST4920 Track Recoil Spring Disassembly and Assembly Tool.

Material required:

- 3/16 in. 1020 CR Steel Plate (A)
- 1/2 in. Nut (C) (2 used)
- 1/2 x 2 in. Cap Screw (D) (2 used)
- 1/2 x 3 in. Steel Round Stock (E) (2 used)

TX,01,RB432 -19-19APR06-1/1

T7162AF—UN—17OCT89



**DFT1130 Adapter**

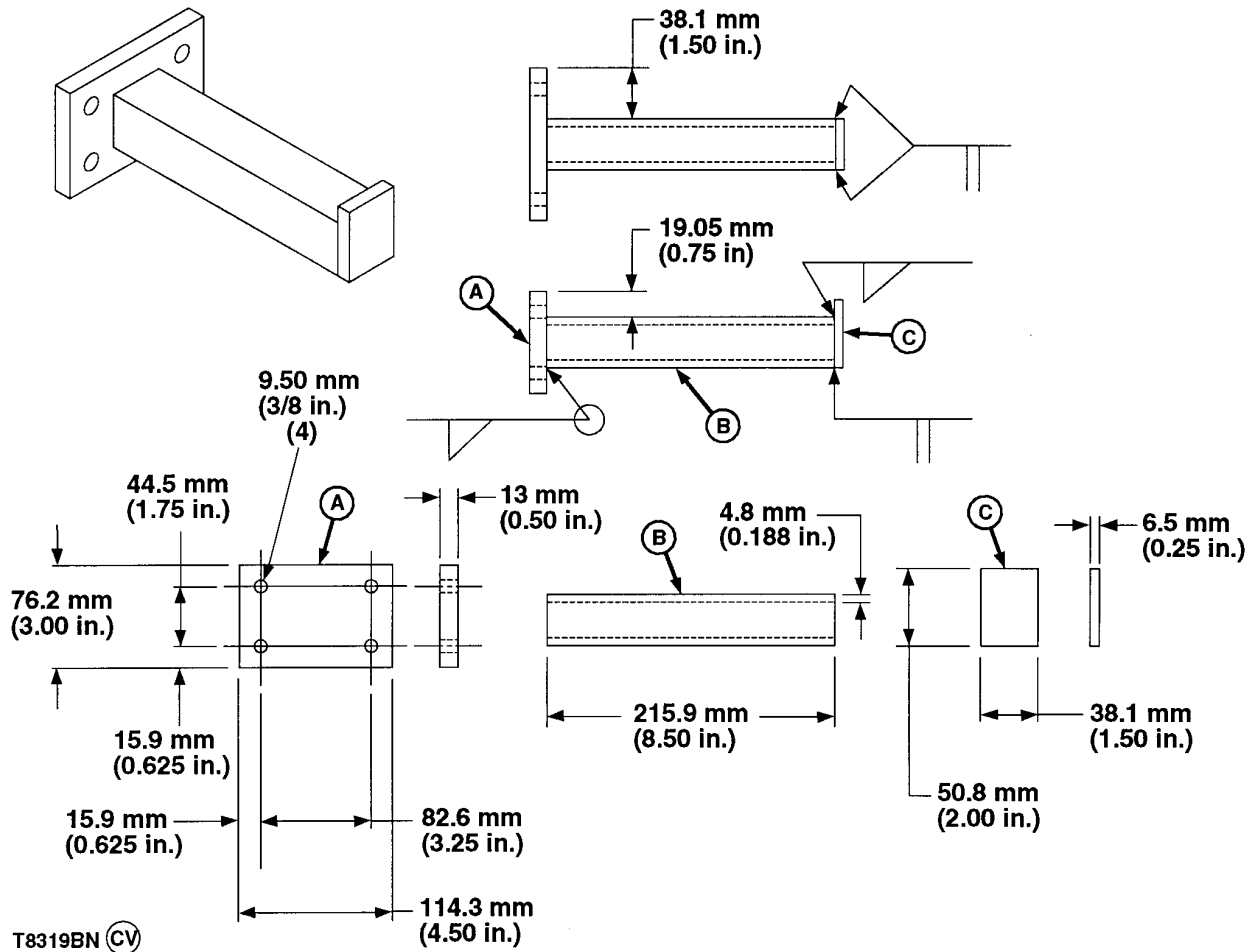

A—Adapter Plate

B—Tube

C—Stop Plate

Adapter is used with DFT1063 Pump Lifting Bracket to remove and install hydrostatic pumps.

Material required:

- 1/2 in. 1020 Steel Plate (A)
- 1-1/2 in. x 1-1/2 in. x 3/16 in. Square Tube (B)
- 1/4 in. 1020 Steel Plate (C)

TX,9900,YY1199 -19-13APR99-1/1

T8319BN—UN—20SEP94

### DFT1132 Hydrostatic Motor Removal and Installation Tool

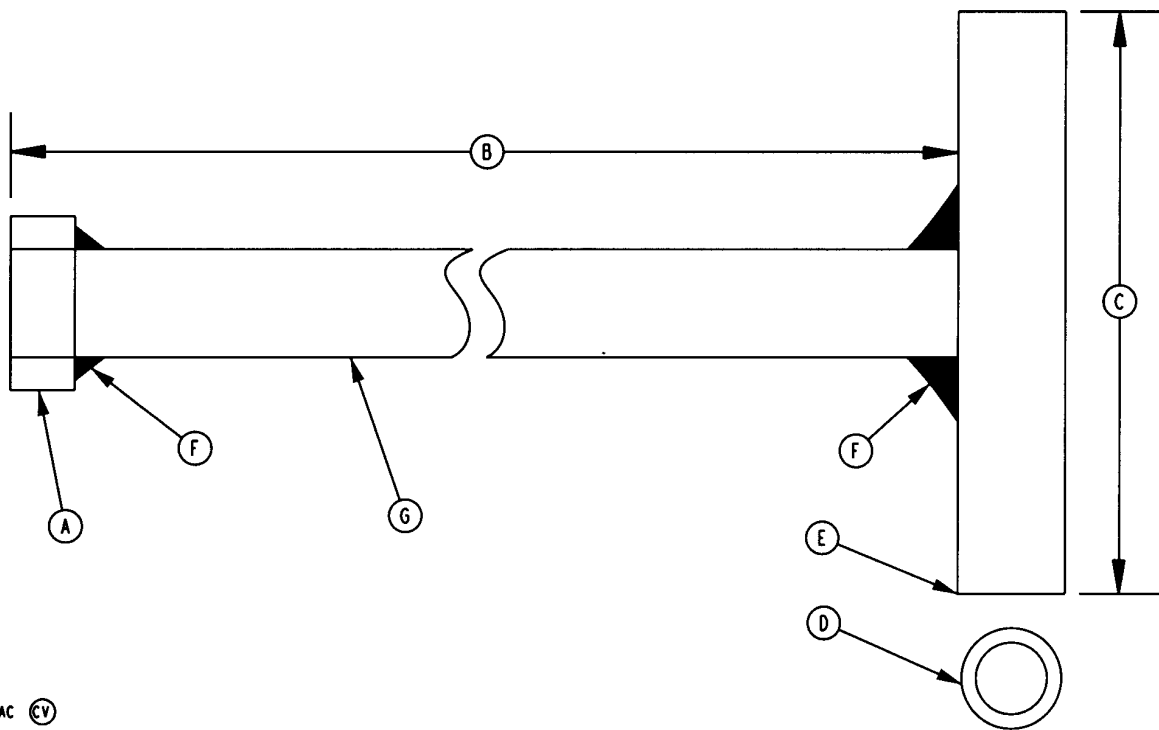

T8366AC ©

T8366AC—UN—10JUL95

- |                            |                                  |        |
|----------------------------|----------------------------------|--------|
| A—1 in. Nut                | C—Pipe 457 mm (18 in.) Long      | E—Pipe |
| B—Pipe 2134 mm (7 ft) Long | D—1 in. ID Heavy Wall Steel Pipe | F—Weld |

G—Pipe

This tool is used to remove and install hydrostatic motors from rear of machine.

Material required:

- 1 in. piece heavy wall steel pipe 8 ft. x 6 in. long
- Weld (E) to (G)

CED,TX03399,5070 -19-01DEC09-1/1

### DFT1137 Hydrostatic Motor Removal and Installation Tool

**IMPORTANT: Modification to tool as shown must be made for right side motor removal.**

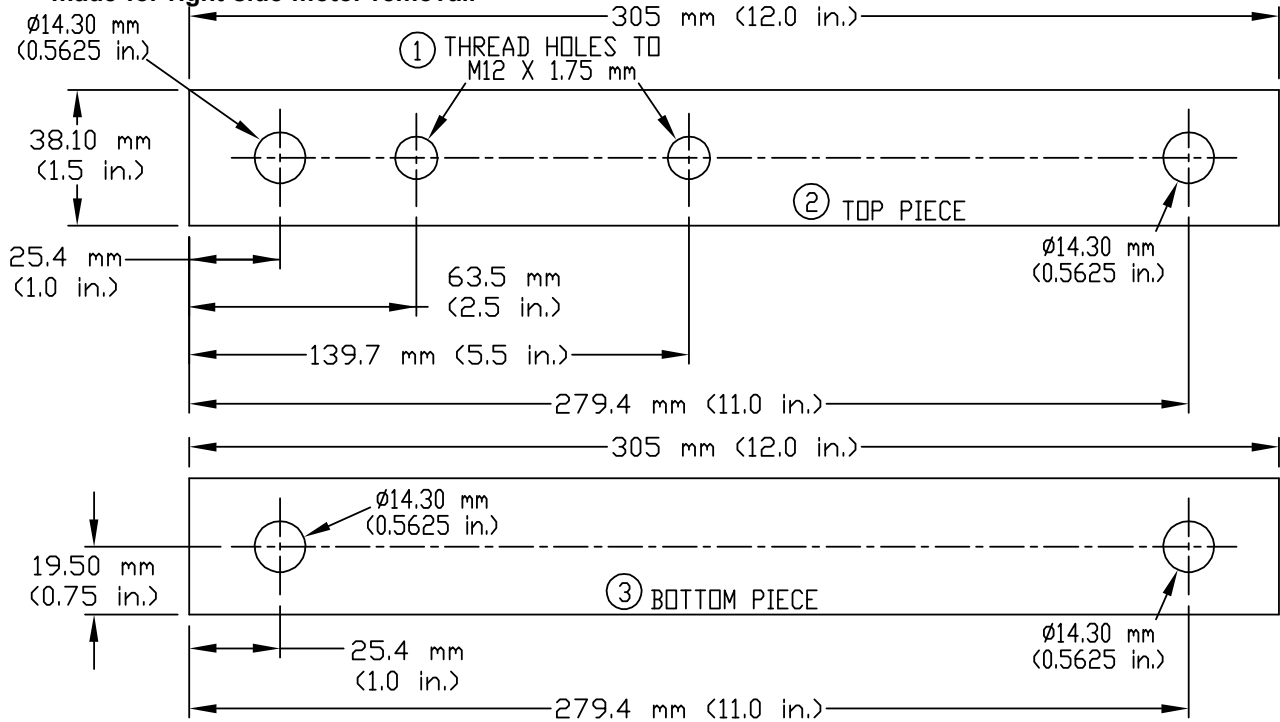

TX1074263

DFT1137 Hydrostatic Motor Removal and Installation Tool

1— Thread Holes to M12 x 1.75 mm

2— Top Piece

3— Bottom Piece

This tool will need to be modified with second threaded hole to allow right side hydrostatic motor to attain correct index position. This tool is to be used with DFT1132 to remove and install hydrostatic motors from rear access hole in frame.

Material required:

- 1-1/2 in. x 3/4 in. x 12 in. long steel bars (2 used)

- M12 x 1.75 eyebolt
- 1/2 in. x 9 in. cap screws with nuts and washers

Install and tighten eyebolt in bracket. Trim any excess eyebolt material so it is even with bottom surface of bracket.

CED,OUO1065,1021 -19-22MAR10-1/1

TX1074263—UN—22APR10

**DFT1165 Left Hand Hydrostatic Motor Lifting Bracket**

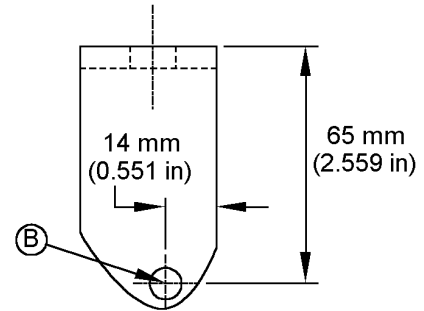
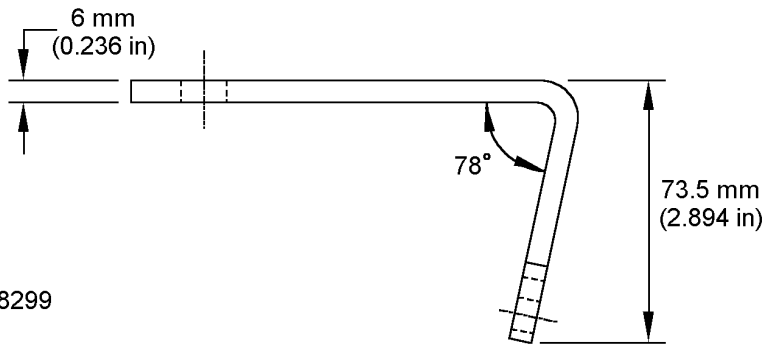
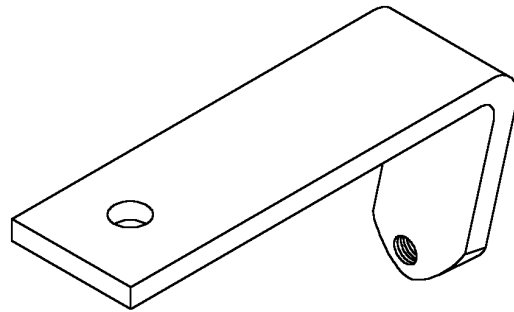
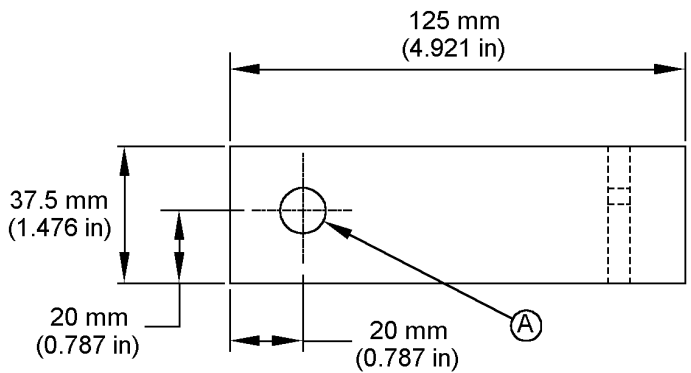

**A**—12 mm (0.472 in.) hole      **B**—M10 x 1.5 drill and tap hole

Used with DFT1132 Hydrostatic Motor Removal and Installation Tool to remove and install hydrostatic left hand motor.

Material: 1020 Flat Stock 7-7/8 in. long, 1/4 x 1-1/2 in.

CED,TX03399,5068 -19-13APR99-1/1

**DFT1166 Final Drive Lifting Bracket Adapter**

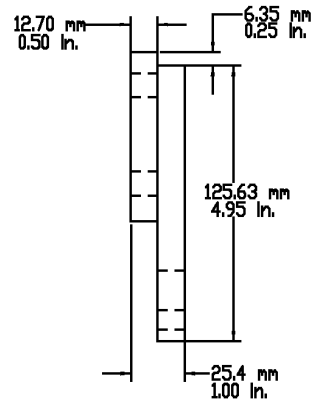
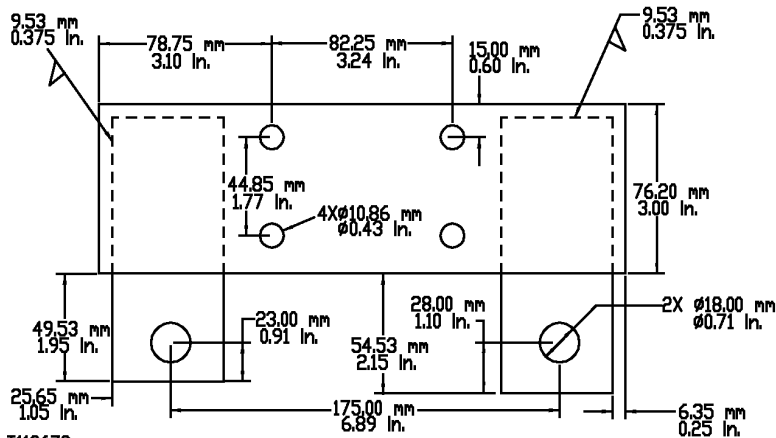
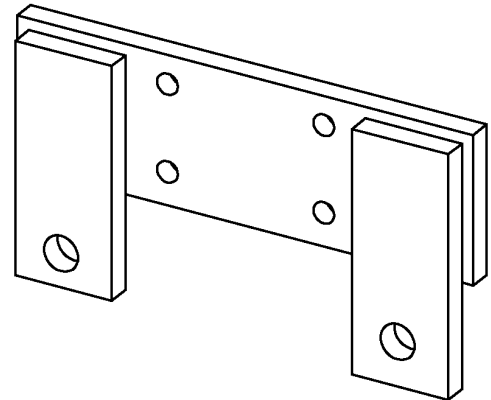
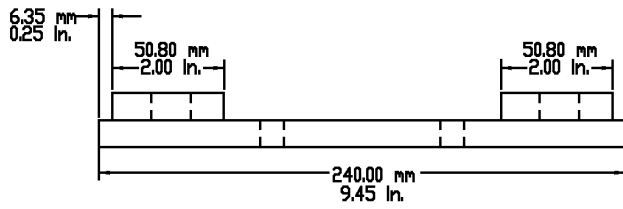

To be used with DFT1063 Final Drive Lifting Bracket and DFT1167 Final Drive Lifting Bracket Adapter Spacer.

Material: 1/2 in. 1020 Steel

T118673

T118673—UN—01DEC98

CED,TX03399,5084 -19-30NOV98-1/1

### DFT1167 Final Drive Lifting Bracket Adapter Spacer

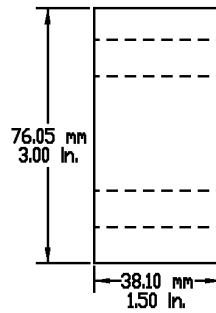
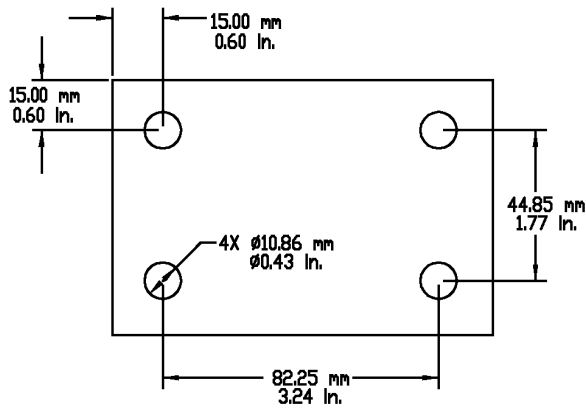
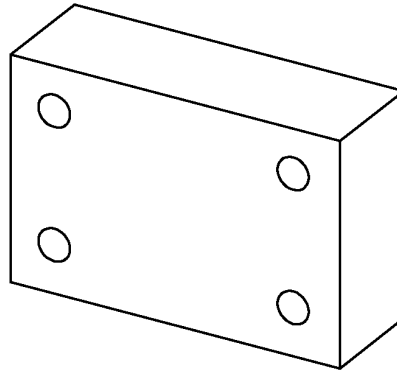
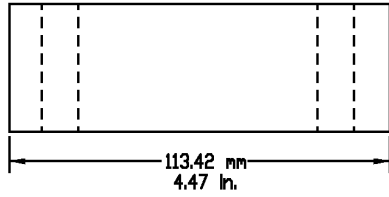

T118674

T118674—UN—01DEC98

To be used with DFT1166 Final Drive Lifting Bracket Adapter when installing DFT1063 Final Drive lifting Bracket.

Material: 1/2 in. 1020 Steel Plate

CED,TX03399,5085 -19-19APR06-1/1

### DFT1168 Right Hand Hydrostatic Motor Lifting Bracket

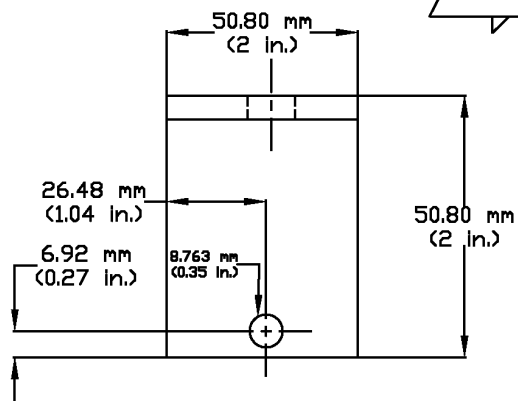
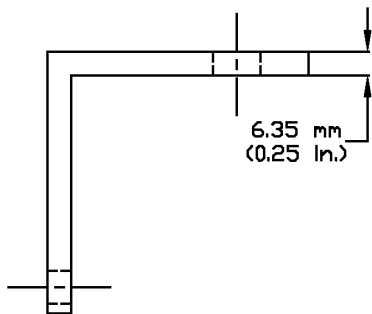
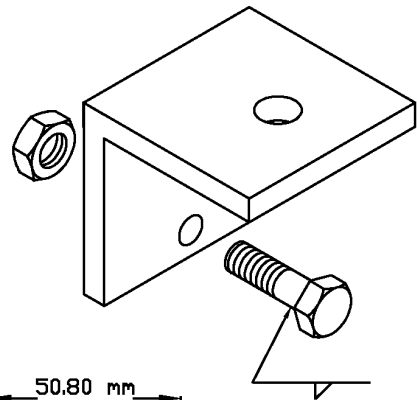
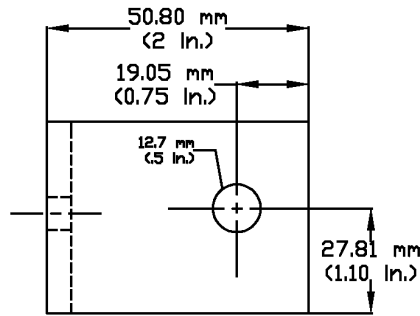

T118914

A—12 mm (0.472 in.) hole      B—M10 x 1.5 drill and tap hole

Used with DFT1132 Hydrostatic Motor Removal and Installation Tool to remove and install hydrostatic right hand motor (without winch option).

Material required:

- 2 in. x 2 in. x 1/4 in. angle iron
- 5/16 x 1-1/2 in. cap screw

Cap screw must be welded to angle iron.

CED,OUO1008,160 -19-13APR99-1/1

T118914—UN—06JAN99

### DFT1211 Final Drive Lifting Bracket Adapter

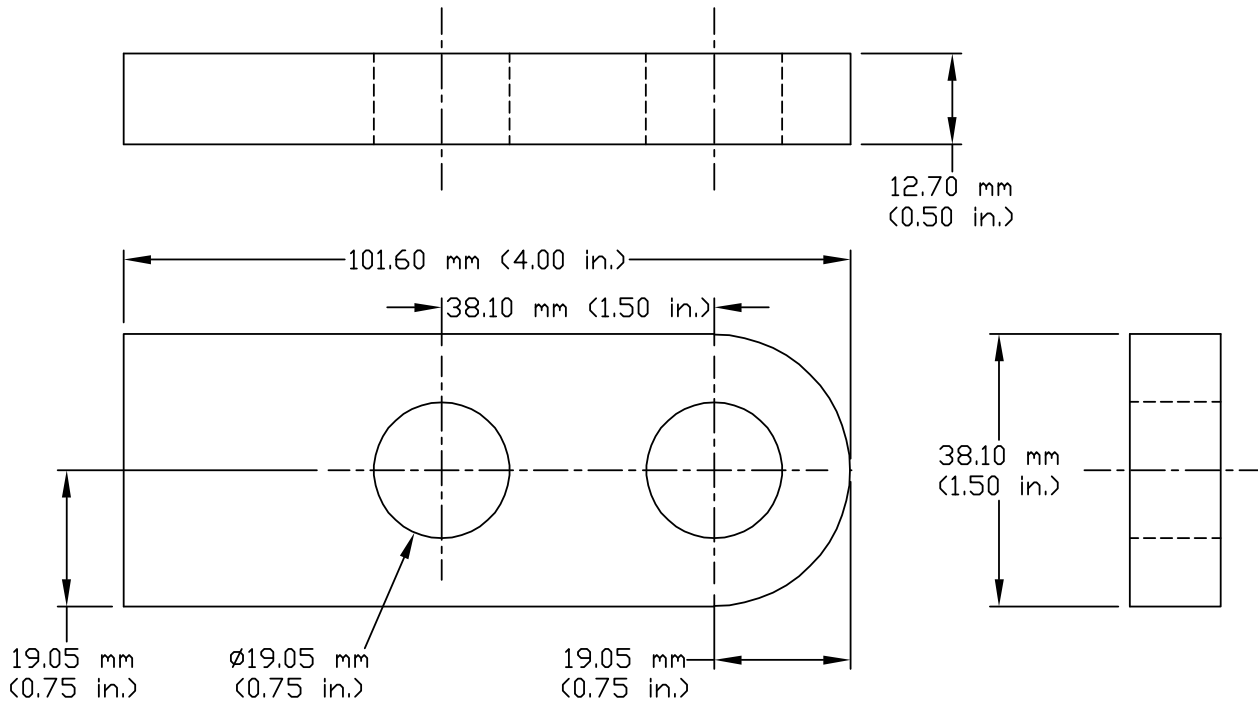

TX1074262

Lifting Bracket Adapter

Adapter used with JT01748 Lifting Bracket to remove and install final drive.

- 1/2 in. 1020 steel plate 1.5 x 4 in.

Material required:

TX1074262—UN—05APR10

CED.OUO1065,1020 -19-22MAR10-1/1

### DFRW20 Compressor Holding Fixture

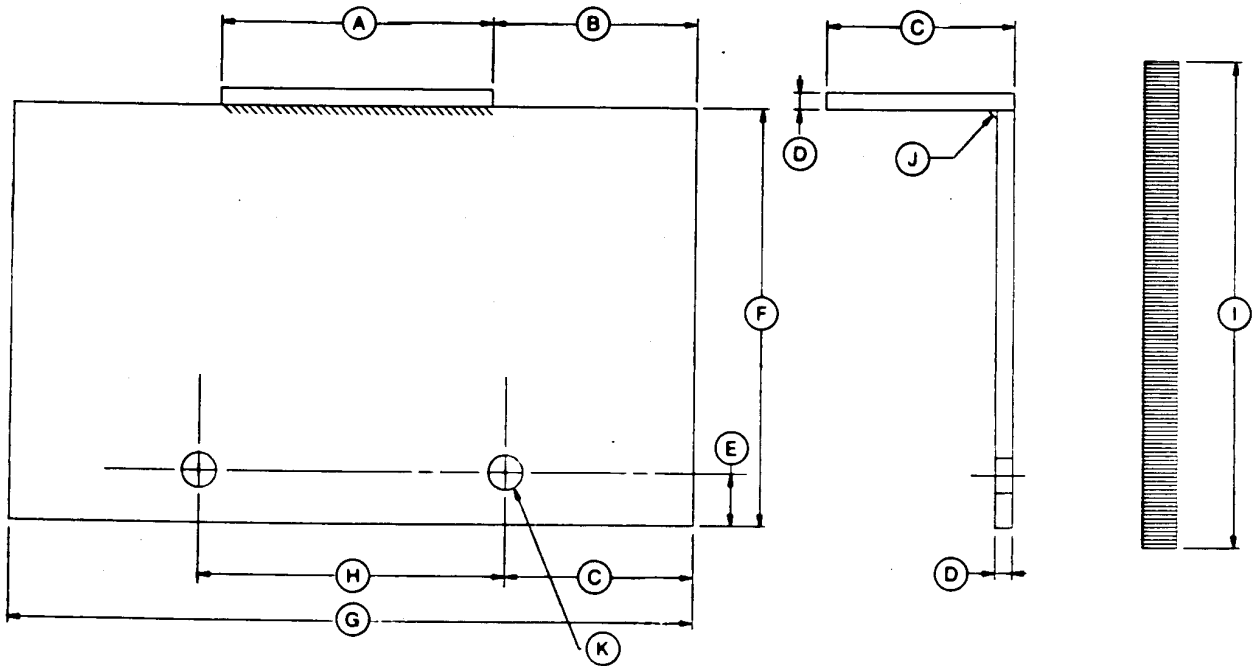

A—102 mm (4 in.)  
 B—76 mm (3 in.)  
 C—70 mm (2.75 in.)

D—6.4 mm (0.25 in.)  
 E—19 mm (0.75 in.)  
 F—152 mm (6 in.)

G—254 mm (10 in.)  
 H—114 mm (4.5 in.)  
 I—178 mm (7 in.)

J— Fillet Weld  
 K—Two Holes

**Material required:**

- 2—Steel Plates (4 x 2.75 in.) and (10 x 6 in.)
- 2—Threaded Steel Rods (0.5 x 7 in.)

- 4—Matching Lock Washers and Nuts

Tool is used to hold air conditioning compressor during assembly and disassembly.

TX,18,RB766 -19-19APR06-1/1

RW13619 —UN—20SEP89

## ST4920 Track Recoil Spring Disassembly and Assembly Tool

*NOTE: It is recommended that DFT1087 Track Recoil Spring Disassembly and Assembly Guard Tool be used with track recoil spring disassembly and assembly tool.*

*Dimensions given are metric.*

Tool is the same as used on other machines except the holder (C). For each track adjuster use the holder with the correct size hole for the nut on that track adjuster.

Track Recoil Spring Disassembly and Assembly Tool (compression tool) is used with hydraulic jack to compress recoil spring in track adjuster repair.

Material required:

- 1020 HR Steel for Holder (C), Supporting Plate (E), Base Plate (F), and Base (G).
- "D" Grade (SAE Grade 5) for Eyebolts (D), Nuts (A), and Cap Screws (H).
- "F" Grade (SAE Grade 8) for Studs (B).

Print Numbers:

- A—ST4050 Nut
- B—ST4045 Bolt
- C—ST4035 Holder (Plate)  
- ST4036 Holder (Plate)  
- ST4037 Holder (Plate)
- D—ST4047 Eyebolt
- E—ST4040 Supporting Base
- F—ST4042 Base Plate
- G—ST4041 Base
- H—ST4046 Cap Screw
- I—ST4049 Lock Washer

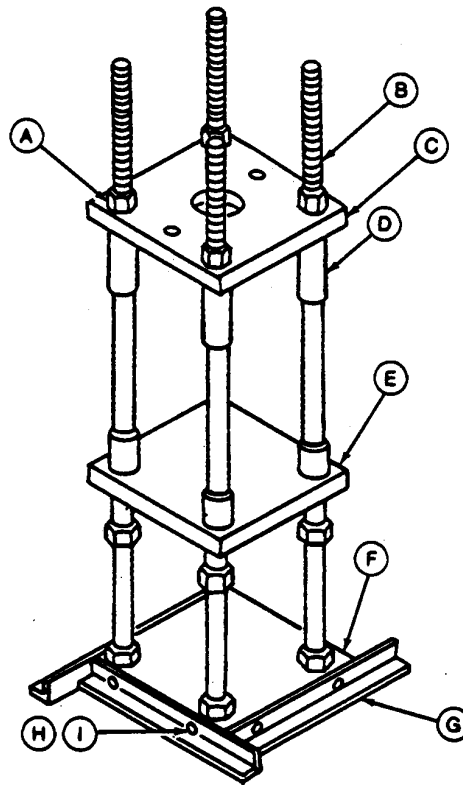

- |                    |                        |
|--------------------|------------------------|
| A—Nut (12 used)    | F—Base Plate           |
| B—Stud (4 used)    | G—Base (4 used)        |
| C—Holder           | H—Cap Screw (8 used)   |
| D—Eyebolt (2 used) | I—Lock Washer (8 used) |
| E—Supporting Plate |                        |

Continued on next page

TX,01, RB519 -19-19APR06-1/4

T6585UY — JUN—24MAR98

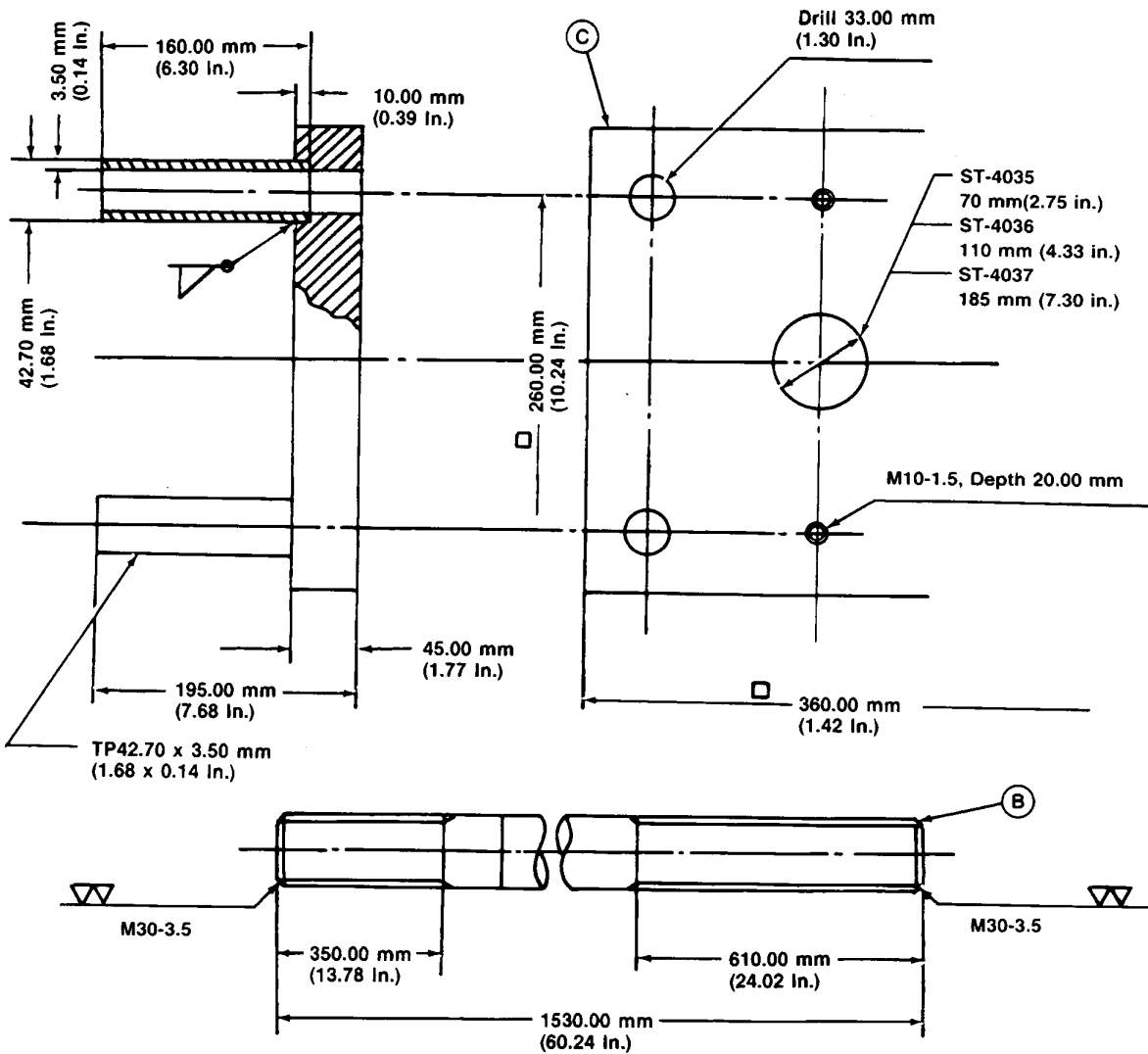

Continued on next page

TX,01,RB519 -19-19APR06-2/4

T7029CI—UN—06JUL89

Dealer Fabricated Tools

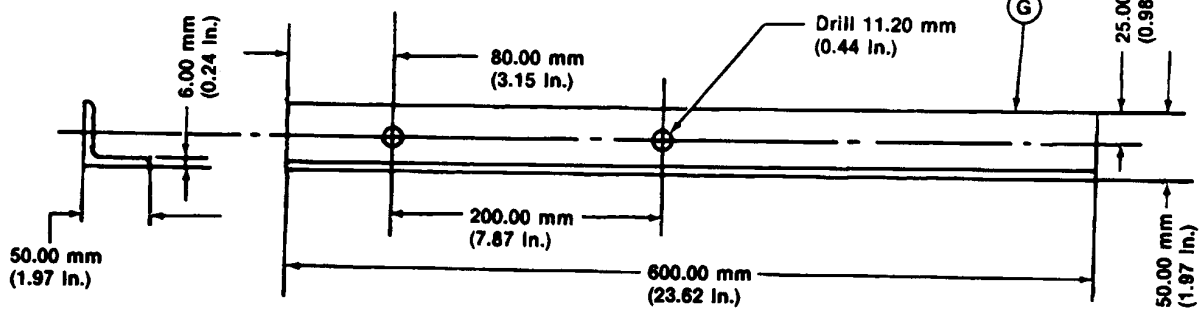
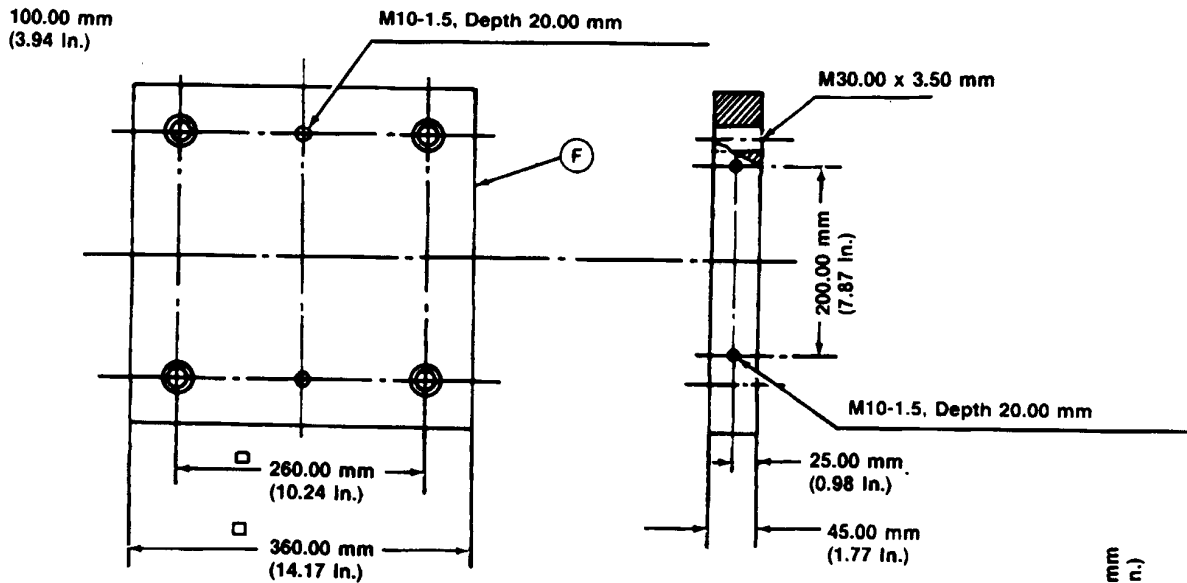
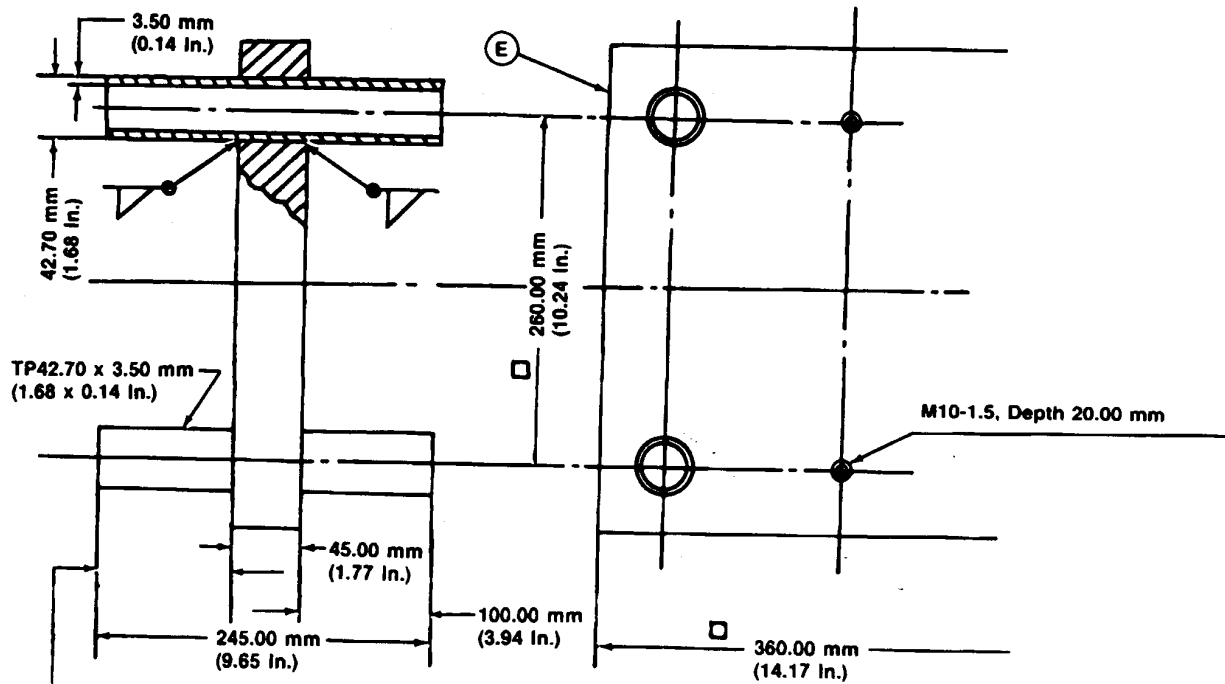

T7029CH—UN—06JUL89

Continued on next page

TX,01, RB519 -19-19APR06-3/4



*Dealer Fabricated Tools*

# Index

	Page		Page
<b>A</b>			
A/C freeze switch		Carrier roller	
Remove and install .....	18-1830-11	Disassemble and assemble .....	01-0130-5
Adjuster		Remove and install .....	01-0130-2
Track tension, assemble and install .....	01-0130-40	Chain	
Track tension, remove and disassemble .....	01-0130-38	Lubricated track, assembly (Turn Bushings and Lubricate Chain) .....	01-0130-22
Air conditioning		Lubricated track, disassembly (Turn Bushings and Lubricate Chain) .....	01-0130-20
Cleaning procedures .....	18-1830-7	Lubricated track, disassembly (Turn Pins and Not Lubricate) .....	01-0130-29
Clutch hub clearance .....	18-1830-24	Lubricated track, remove and install .....	01-0130-17
Compressor clutch .....	18-1830-23	Sealed track, disassemble and assemble .....	01-0130-15
Leak testing .....	18-1830-3	Sealed track, installation .....	01-0130-15
Air conditioning compressor		Sealed track, removal .....	01-0130-11
Remove and install .....	18-1830-19, 18-1830-21	Chain guides and rock guards	
Air suspension seat		Remove and install .....	01-0130-1
Remove and install .....	18-1821-15	Charge filter	
Angle control valve section		Hydraulic, Remove and install .....	21-2160-15
Disassemble and assemble .....	32-3260-10	Charge pump, disassemble and assemble .....	03-0360-9
Angle cylinder		Chemical products	
Assemble .....	32-3260-21	Handling .....	00-01-4
Disassemble .....	32-3260-21	Cleaning procedures	
Remove and install .....	32-3260-20	Air conditioning .....	18-1830-7
Auxiliary control linkage		Cleanout cover	
Remove and install .....	32-3215-3	Remove and install .....	21-2160-11
Auxiliary control valve section		Clutch hub clearance .....	18-1830-24
Disassemble and assemble .....	32-3260-9	Compressor	
<b>B</b>			
Battery		Disassemble and assemble .....	18-1830-25
Explosions, prevent .....	00-01-4	Disassemble and assemble clutch .....	18-1830-23
Blade, dozer		Oil charge check .....	18-1830-1
Remove and install .....	32-3201-1	Oil removal .....	18-1830-1
Blade, Dozer		Remove and install .....	18-1830-19, 18-1830-21
Split Bearing Installation .....	32-3201-3	Compressor manifold	
Brake pedal		Inspect .....	18-1830-24
Disassemble and assemble .....	05-0515-2	Condenser	
Remove and install .....	05-0515-1	Remove and install .....	18-1830-18
Brake valve		Control Lever (Integrated Grade Control) (IGC)	
Disassemble and assemble .....	11-1160-1	Disassemble and assemble .....	32-3260-17
Remove and install .....	11-1100-1	Remove and install .....	32-3260-15
Brake, park		Cooling package	
Remove and install .....	11-1100-1	Remove and install (450H, 550H) .....	05-0510-3
Brakes, park		Remove and install (650J) .....	05-0510-4
Disassemble and assemble .....	11-1160-2	Cover, cleanout	
<b>C</b>			
C-Frame		Hydraulic and hydrostatic reservoirs .....	21-2160-11
Remove and Install .....	32-3240-1	Cutting edges and end bits	
Cab under seat heater		Remove and install .....	32-3201-4
Disassemble and assemble .....	18-1830-16	Cylinder, angle	
Cab upper heater		Assemble .....	32-3260-21
Disassemble and assemble .....	18-1830-14	Disassemble .....	32-3260-21
Cab/ROPS		Remove and install .....	32-3260-20
Remove and Install .....	18-1800-1	Cylinder, lift	
		Assemble .....	32-3260-21
		Disassemble .....	32-3260-21
		Remove and install .....	32-3260-21

Continued on next page

Index

	Page		Page
Cylinder, tilt		<b>F</b>	
Assemble .....	32-3260-21		
Disassemble .....	32-3260-21		
Remove and install .....	32-3260-19		
<b>D</b>			
Dampener drive			
Remove and install .....	07-0752-1		
Dealer fabricated tool			
DF1041 Track nut removal tool.....	9900-0999-1		
DF1063 Final drive lift bracket .....	9900-0999-2		
DFRW20 Compressor holding fixture .....	9900-0999-13		
DFT1087 track recoil spring guard.....	9900-0999-3		
DFT1119 Pump support.....	9900-0999-4		
DFT1130 adapter.....	9900-0999-5		
DFT1132 hydrostatic motor removal .....	9900-0999-6		
DFT1167 Final drive lifting bracket adapter spacer .....	9900-0999-10		
DFT1211 Final drive lifting bracket adapter .....	9900-0999-12		
Left hand hydrostatic motor lifting bracket .....	9900-0999-8		
Right hand hydrostatic motor lifting bracket .....	9900-0999-11		
ST4920 track recoil spring disassembly and assembly tool .....	9900-0999-14		
Decelerator pedal			
Disassemble and assemble .....	05-0515-2		
Remove and install .....	05-0515-1		
Disassemble and assemble			
Cab upper heater .....	18-1830-14		
Compressor .....	18-1830-25		
Dozer blade			
Remove and install .....	32-3201-1		
Dozer Blade			
Split Bearing Installation .....	32-3201-3		
<b>E</b>			
Emergencies			
Prepare for .....	00-01-5		
Engine			
Remove and install .....	04-0400-1		
Engine side shields			
Remove and install .....	19-1910-3		
Equipment, protective			
Wear .....	00-01-2		
Evaporator			
Remove and install .....	18-1830-9		
Expansion valve			
Remove and install .....	18-1830-11		
<b>F</b>			
Fan blade			
Remove and install (450, 550H) .....	05-0510-1		
Remove and install (650H) .....	05-0510-2		
Fan shroud			
Remove and install (450H, 550H).....	05-0510-1		
Remove and install (650H) .....	05-0510-2		
Filter			
Hydraulic charge, Remove and install .....	21-2160-15		
Filter assembly			
Hydraulic charge, disassemble and assemble.....	21-2160-16		
Filter, hydrostatic			
Disassemble and assemble .....	03-0360-46		
Remove and install .....	03-0360-44		
Final drive			
Disassemble and assemble .....	02-0250-1		
Remove and install .....	02-0201-1		
Final drive lift bracket.....	9900-0999-2		
Fires, prevent.....	00-01-4		
Fluids, high pressure			
Avoid .....	00-01-3		
Frame			
Track, remove and install .....	01-0130-47		
Frame wear strips			
Remove and install .....	01-0130-50		
Front idler			
Adjustment .....	01-0130-36		
Disassemble, inspect, and assemble.....	01-0130-34		
Oil level check.....	01-0130-37		
Remove and install .....	01-0130-33		
Fuel tank			
Remove and install.....	05-0560-1		
Fumes, exhaust			
Beware.....	00-01-3		
<b>G</b>			
Grille and grille housing			
Remove.....	19-1921-1		
<b>H</b>			
Heater blower resistor			
Remove and install .....	18-1830-12		
Heater core, upper			
Remove and install .....	18-1830-9		
Hood			
Remove and install .....	19-1910-1		
Hood support			
Remove and install .....	19-1910-3		
Hydraulic			
Charge filter assembly, disassemble and assemble.....	21-2160-16		
Charge filter, Remove and install .....	21-2160-15		
Fittings, 30°; cone seat .....	00-03-4		

Continued on next page

Index

	Page		Page
Fittings, 37&deg; flare .....	00-03-4	Front, oil level check .....	01-0130-37
Hydraulic charge filter assembly		Front, remove and install .....	01-0130-33
Disassemble and assemble .....	21-2160-16	Inch bolt and cap screw	
Hydraulic charge filter		Torque value .....	00-03-3
Remove and install .....	21-2160-15	Inch series four bolt flange fitting	
Hydraulic control valve		Service recommendation, torque value for	
Disassemble and assemble .....	32-3260-2	high pressure .....	00-03-17
Disassemble and assemble lift		Inspect	
section .....	32-3260-13	Compressor manifold .....	18-1830-24
Disassemble and assemble tilt			
section .....	32-3260-12	<b>J</b>	
Remove and install .....	32-3260-1	Joystick (Integrated Grade Control) (IGC)	
Wiper seals and lip seals, replace .....	32-3260-3	Disassemble and assemble .....	32-3260-17
Hydraulic fitting		Remove and install .....	32-3260-15
Flared connections .....	00-03-7	<b>L</b>	
Non-restricted banjo (adjustable) .....	00-03-18	Lift cylinder	
O-ring boss with shoulder .....	00-03-19	Assemble .....	32-3260-21
Hydraulic pump		Disassemble .....	32-3260-21
Disassemble and assemble (with winch		Remove and install .....	32-3260-21
option) .....	21-2160-3	Linkage	
Disassemble and assemble (without		Auxiliary, remove and install .....	32-3215-3
winch option) .....	21-2160-7	T-bar, remove and install .....	32-3215-1
Remove and install .....	21-2160-1	Linkage, park lock	
Hydraulic reservoir		Remove and Install .....	11-1115-1
Disassemble and assemble .....	21-2160-14	Linkage, single lever control	
Remove and install .....	21-2160-9	Disassemble and assemble .....	03-0315-2
Hydraulic reservoir cleanout cover		Loop flushing valve	
Remove and install .....	21-2160-11	Assemble .....	03-0360-32
Hydrostatic filter		Lubricated track chain	
Disassemble and assemble .....	03-0360-46	Assembly (Turn Bushings and Lubricate	
Remove and install .....	03-0360-44	Chain) .....	01-0130-22
Hydrostatic motor		Disassembly (Turn Bushings and	
Assemble .....	03-0360-32	Lubricate Chain) .....	01-0130-20
Disassemble .....	03-0360-26	Disassembly (Turn Pins and Not	
Hydrostatic motors		Lubricate) .....	01-0130-29
Remove and install .....	03-0300-10	Remove and install .....	01-0130-17
Hydrostatic pump		<b>M</b>	
Assemble .....	03-0360-18	Machine modifications	
Charge pump, disassemble and		Avoid .....	00-01-2
assemble .....	03-0360-9	Machine, inspect .....	00-01-2
Multifunction valve, disassemble and		Metal face seals	
assemble .....	03-0360-16	Inspection .....	01-0130-6
Neutral charge relief valve, disassemble		Metric bolt and cap screw	
and assemble .....	03-0360-17	Torque value .....	00-03-1
Pump displacement control valve (PDCV),		Motor shift solenoid valve	
disassemble and assemble .....	03-0360-14	Assemble .....	03-0360-32
Hydrostatic pumps		Disassemble .....	03-0360-26
Remove and install .....	03-0300-1	Install .....	03-0360-32
Hydrostatic reservoir		Remove .....	03-0360-26
Remove and Install .....	03-0360-47	Muffler w/o turbocharger	
Hydrostatic reservoir cleanout cover		Remove and install .....	05-0530-1
Remove and install .....	21-2160-11	Muffler with turbocharger	
<b>I</b>		Remove and install .....	05-0530-2
Idler			
Front, adjustment .....	01-0130-36		
Front, disassemble, inspect, and			
assemble .....	01-0130-34		

Continued on next page

Index

	Page		Page
Multi-function valve, disassemble and assemble .....	03-0360-16	Purge .....	18-1830-7
		Recover.....	18-1830-4
<b>N</b>		Radiator and oil cooler	
Neutral charge relief valve, disassemble and assemble .....	03-0360-17	Remove and install (450H, 550H).....	05-0510-3
		Remove and install (650J) .....	05-0510-4
<b>O</b>		Rear window wiper	
O-ring boss fitting in aluminum housing excavators		Remove and install .....	18-1810-10
Torque value, service recommendation .....	00-03-6	Receiver-dryer	
O-ring boss fittings.....	00-03-4	Remove and install .....	18-1830-18
O-ring face seal fitting		Recognize	
Inch hex nut and stud end for high pressure torque values.....	00-03-9	Safety, information .....	00-01-1
Metric hex nut and stud end for high pressure torque values.....	00-03-13	Recovery/charging station	
Metric hex nut and stud end for standard pressure torque values.....	00-03-11	Installation procedure.....	18-1830-3
O-ring seal, metric 24		Refrigerant R134a caution.....	18-1830-1
Service recommendation .....	00-03-21	Remove and install	
Oil cooler and radiator		Condenser .....	18-1830-18
Remove and install (450H, 550H).....	05-0510-3	Heater blower resistor.....	18-1830-12
Remove and install (650J).....	05-0510-4	Receiver-dryer .....	18-1830-18
Operating charge relief valve		Upper cab heater blower motor .....	18-1830-12
Assemble .....	03-0360-32	Reservoir cover	
Disassemble .....	03-0360-26	Remove and install .....	21-2160-11
Install.....	03-0360-32	Reservoir, hydraulic	
Remove.....	03-0360-26	Disassemble and assemble .....	21-2160-14
Operation qualification.....	00-01-1	Rock guards and chain guides	
		Remove and install .....	01-0130-1
<b>P</b>		Roller	
Park brake		Carrier, disassemble and assemble.....	01-0130-5
Disassemble and assemble.....	11-1160-2	Carrier, remove and install.....	01-0130-2
Remove and Install .....	11-1100-1	Track, disassemble and assemble.....	01-0130-8
Park brake valve		Track, leakage test.....	01-0130-9
Remove and install .....	11-1100-1	Track, remove and install.....	01-0130-7
Park lock linkage		ROPS under seat heater	
Remove and install .....	11-1115-1	Disassemble and assemble .....	18-1830-16
Parts, moving		ROPS/cab	
Stay clear .....	00-01-2	Remove and Install .....	18-1800-1
Pump displacement control valve (PDCV), disassemble and assemble .....	03-0360-14		
Pump, hydraulic		<b>S</b>	
Remove and install .....	21-2160-1	Safety	
		Add cab guarding for special uses.....	00-01-5
<b>R</b>		Avoid backover accidents .....	00-01-7
R134a		Avoid machine tip over.....	00-01-7
Component oil charge.....	18-1830-2	Avoid work site hazards .....	00-01-6
R134a system		Drive metal pins safely.....	00-01-9
Charge .....	18-1830-6	Instructions, follow .....	00-01-1
Evacuate .....	18-1830-5	Keep riders off machine.....	00-01-6
Flush .....	18-1830-8	Make welding repairs safely.....	00-01-9
		Park and prepare for service safely .....	00-01-8
		Prevent unintended machine movement .....	00-01-6
		Start only from operator's seat.....	00-01-5
		Safety, information	
		Recognize .....	00-01-1
		Sand shield	
		Remove and install .....	05-0510-7
		Sealed track chain	
		Disassemble and assemble .....	01-0130-15
		Installation.....	01-0130-15
		Removal.....	01-0130-11

Continued on next page

	Page		Page
Seals		Tool, dealer fabricated	
Metal face, inspection .....	01-0130-6	DF1041 Track nut removal tool.....	9900-0999-1
Seat, deluxe		DF1063 Final drive lift bracket.....	9900-0999-2
Remove and install .....	18-1821-5	DFRW20 Compressor holding	
Seat, standard		fixture .....	9900-0999-13
Remove and install .....	18-1821-1	DFT1087 track recoil spring guard.....	9900-0999-3
Service recommendation		DFT1119 Pump support.....	9900-0999-4
Inch series four bolt flange fitting for high		DFT1167 Final drive lifting bracket adapter	
pressure .....	00-03-17	spacer .....	9900-0999-10
O-ring boss fitting in aluminum		DFT1211 Final drive lifting bracket	
housingexcavators .....	00-03-6	adapter.....	9900-0999-12
O-ring face seal fittings with inch hex nut		ST4920 track recoil spring disassembly	
and stud end for high pressure .....	00-03-9	and assembly tool .....	9900-0999-14
O-ring face seal fittings with metric hex		Tools, dealer fabricated	
nut and stud end for high pressure .....	00-03-13	DFT1130 adapter.....	9900-0999-5
O-ring face seal fittings with metric hex nut		DFT1132 hydrostatic motor	
and stud end for standard pressure .....	00-03-11	removal .....	9900-0999-6
O-ring seal, metric 24.....	00-03-21	Left hand hydrostatic motor lifting	
Shield, sand		bracket .....	9900-0999-8
Remove and install .....	05-0510-7	Right hand hydrostatic motor lifting	
Shoe		bracket .....	9900-0999-11
Track, remove and install.....	01-0130-9	Torque value	
Single lever control		30&deg; cone seat hydraulic fittings .....	00-03-4
Remove and install .....	03-0315-1	37&deg; flare hydraulic fittings.....	00-03-4
Single lever control linkage		Flared connections.....	00-03-7
Disassemble and assemble .....	03-0315-2	Flat face O-ring seal fitting .....	00-03-8
Slide glass		Inch SAE four bolt flange fitting.....	00-03-16
Remove and install .....	18-1810-1	Inch series four bolt flange fitting for high	
Split Bearing		pressure .....	00-03-17
Installation.....	32-3201-3	Metric bolt and cap screw .....	00-03-1
Spring		Metric cap screw .....	00-03-2
Track idler recoil, disassemble and		Metric four bolt flange fitting.....	00-03-15
assemble.....	01-0130-42	Non-restricted banjo fittings .....	00-03-18
Track idler recoil, remove and install .....	01-0130-41	O-Ring boss fitting .....	00-03-4
Sprocket		O-ring boss fitting in aluminum	
Remove and Install .....	01-0130-46	housingexcavators .....	00-03-6
Starting aid solenoid		O-ring boss fittings with shoulder.....	00-03-19
Remove and install .....	05-0505-3	O-ring face seal fittings with inch hex nut	
Start aid		and stud end for high pressure .....	00-03-9
Remove and install .....	05-0505-2	O-ring face seal fittings with metric hex	
Stationary glass		nut and stud end for high pressure .....	00-03-13
Remove and install .....	18-1810-2	O-ring face seal fittings with metric hex nut	
Support, hood		and stud end for standard pressure .....	00-03-11
Remove and install .....	19-1910-3	O-ring seal, metric 24.....	00-03-21
Switch, A/C freeze		Unified inch bolt and cap screw .....	00-03-3
Removel and install.....	18-1830-11	Track chain	
System relief valve		Lubricated, assembly (Turn Bushings and	
Disassemble and assemble .....	32-3260-18	Lubricate Chain).....	01-0130-22
		Lubricated, disassembly (Turn Bushings	
		and Lubricate Chain).....	01-0130-20
		Lubricated, disassembly (Turn Pins and	
		Not Lubricate).....	01-0130-29
		Lubricated, remove and install .....	01-0130-17
		Sealed, disassemble and assemble .....	01-0130-15
		Sealed, installation.....	01-0130-15
		Sealed, removal .....	01-0130-11
		Track frame	
		Remove and install .....	01-0130-47

**T**

T-bar control linkage			
Remove and install .....	32-3215-1		
Thermal bypass valve			
Remove and install .....	03-0360-44		
Tilt cylinder			
Assemble .....	32-3260-21		
Disassemble .....	32-3260-21		
Remove and install .....	32-3260-19		

Continued on next page

Index

	Page		Page
Track idler recoil spring		Remove and install .....	32-3260-1
Disassemble and assemble .....	01-0130-42	Valve, section auxiliary	
Remove and install .....	01-0130-41	Disassemble and assemble .....	32-3260-9
Track roller		Valve, system relief	
Disassemble and assemble .....	01-0130-8	Disassemble and assemble .....	32-3260-18
Leakage test .....	01-0130-9		
Remove and install .....	01-0130-7	<b>W</b>	
Track shoe		Waste	
Remove and install .....	01-0130-9	Dispose of properly .....	00-01-5
Track tension adjuster		Wear strips	
Assemble and install .....	01-0130-40	Frame, remove and install .....	01-0130-50
Remove and disassemble .....	01-0130-38	Window wiper	
<b>U</b>		Remove and install .....	18-1810-6, 18-1810-11
Upper cab heater blower motor		Wiper, rear window	
Remove and install .....	18-1830-12	Remove and install .....	18-1810-10
Upper heater core		Wiper, window	
Remove and install .....	18-1830-9	Remove and install .....	18-1810-6, 18-1810-11
<b>V</b>		Wipers, door window	
Valve, hydraulic control		Remove and install .....	18-1810-8
Disassemble and assemble .....	32-3260-2		



*Index*